

# TOXICOLOGY



*Toxicology MSDT*

# Toxicology MSDT



This text is disseminated via the Open Education Resource (OER) LibreTexts Project (<https://LibreTexts.org>) and like the hundreds of other texts available within this powerful platform, it is freely available for reading, printing and "consuming." Most, but not all, pages in the library have licenses that may allow individuals to make changes, save, and print this book. Carefully consult the applicable license(s) before pursuing such effects.

Instructors can adopt existing LibreTexts texts or Remix them to quickly build course-specific resources to meet the needs of their students. Unlike traditional textbooks, LibreTexts' web based origins allow powerful integration of advanced features and new technologies to support learning.



The LibreTexts mission is to unite students, faculty and scholars in a cooperative effort to develop an easy-to-use online platform for the construction, customization, and dissemination of OER content to reduce the burdens of unreasonable textbook costs to our students and society. The LibreTexts project is a multi-institutional collaborative venture to develop the next generation of open-access texts to improve postsecondary education at all levels of higher learning by developing an Open Access Resource environment. The project currently consists of 14 independently operating and interconnected libraries that are constantly being optimized by students, faculty, and outside experts to supplant conventional paper-based books. These free textbook alternatives are organized within a central environment that is both vertically (from advance to basic level) and horizontally (across different fields) integrated.

The LibreTexts libraries are Powered by [NICE CXOne](#) and are supported by the Department of Education Open Textbook Pilot Project, the UC Davis Office of the Provost, the UC Davis Library, the California State University Affordable Learning Solutions Program, and Merlot. This material is based upon work supported by the National Science Foundation under Grant No. 1246120, 1525057, and 1413739.

Any opinions, findings, and conclusions or recommendations expressed in this material are those of the author(s) and do not necessarily reflect the views of the National Science Foundation nor the US Department of Education.

Have questions or comments? For information about adoptions or adaptations contact [info@LibreTexts.org](mailto:info@LibreTexts.org). More information on our activities can be found via Facebook (<https://facebook.com/Libretexts>), Twitter (<https://twitter.com/libretexts>), or our blog (<http://Blog.Libretexts.org>).

This text was compiled on 03/09/2025

# TABLE OF CONTENTS

Licensing

Preface

## 1: Pathophysiology

- 1.1: What is Pathophysiology?
- 1.2: Targeted and Non-Targeted Toxicity
- 1.3: Outcomes of Targeted and Non-Targeted Toxicity
- 1.4: Cellular Response to Toxicant-Induced Injury
- 1.5: Repair & Adaptation
- 1.6: Patterns of Toxic Injury
- Final Evaluation

## 2: Biochemistry and Molecular Genetics

- 2.1: Introduction to Biomolecules and Cell Components
- 2.2: Cell Structure and Subcellular Compartments
- 2.3: DNA and RNA Metabolism
- 2.4: Epigenetic Mechanisms
- Section 2 Final Evaluation

## 3: Principles of Genetic Toxicology

- 3.1: Introduction to Genetic-toxicology Assay
- 3.2: Different Genetic Damages or Mutations
- 3.3: Different Genetic-Toxicology Assays
- 3.4: Different Cytotoxicity Assays
- 3.5: Epigenetics Assay
- Section 3 Final Evaluation

## 4: Applied Systems Toxicology

- 4.1: Systems Toxicology
- 4.2: Dose Level and Applied Toxicology
- 4.3: Tools and Technologies in Systems Toxicology
- 4.4: Other Approaches for Predictive Toxicity Modeling
- 4.5: Technologies Used In Systems Biology/Toxicology
- 4.6: Takeaways Summary
- Section 4 Final Evaluation

## 5: Regulatory Toxicology

- 5.1: Introduction to Regulatory Toxicology
- 5.2: Global Regulatory Toxicology
- 5.3: Topic 3: Regional Regulatory Toxicology
- 5.4: National Regulatory Toxicology
- 5.5: State Regulatory Toxicology
- 5.6: Non-Governmental Regulatory Toxicology
- Section 5 Final Evaluation

## 6: Principles of Toxicology

- Section 1: Introduction to Toxicology
  - 1.1: What is toxicology?
  - 1.2: Basic Terminology
- Section 2: Dose and Dose Response
  - 2.1: Dose and It's Impact on Toxicity
  - 2.2: The Dose Response Relationship
  - 2.3: Dose Estimates of Toxic Effects
  - 2.4: Determining the Safety of a Drug
  - 2.5: NOAEL and LOAEL
- Section 3: Toxic Effects
  - 3.1: Types of Toxic Effects
  - 3.2: Factors Affecting Toxicity
  - 3.3: Systemic Toxic Effects
  - 3.4: Organ Specific Toxic Effects
- Section 4: Interactions
  - 4.1: Interactions
- Section 5: Toxicity Testing Methods
  - 5.1: Testing and Assessing Toxicity
  - 5.2: Clinical Investigations and Other Types of Human Data
  - 5.3: Epidemiology Studies
- Section 6: Risk Assessment
  - 6.1: Risk Assessment
  - 6.2: Hazard Identification
  - 6.3: Dose-Response Assessment
  - 6.4: Exposure Assessment
  - 6.5: Risk Characterization
- Section 7: Exposure Standards and Guidelines
  - 7.1: Exposure Standards and Guidelines
  - 7.2: Regulation of Consumer Products and Drug Safety
  - 7.3: Environmental Exposure Standards/Guidelines
  - 7.4: Occupational (Workplace) Exposure Standards/Guidelines/Approaches
- Section 8: Basic Physiology
  - 8.1: Introduction to Basic Physiology
  - 8.2: Homeostasis
  - 8.3: Organs and Organ Systems
  - 8.4: Tissues
  - 8.5: Cells
  - 8.6: Chemicals
- Section 9: Introduction to Toxicokinetics
  - 9.1: What is Toxicokinetics
- Section 10: Absorption
  - 10.1: Introduction to Absorption
  - 10.2: Gastrointestinal Tract
  - 10.3: Respiratory Tract
  - 10.4: Dermal Route
  - 10.5: Other Routes of Exposure
- Section 11: Distribution

- 11.1: Introduction to Distribution
- 11.2: Influence of Route of Exposure
- 11.3: Disposition Models
- 11.4: Structural Barriers to Distribution
- 11.5: Storage Sites
- Section 12: Biotransformation
  - 12.1: Introduction to Biotransformation
  - 12.2: Chemical Reactions
  - 12.3: Biotransformation Sites
  - 12.4: Modifiers of Biotransformation
- Section 13: Excretion
  - 13.1: Introduction to Secretion
  - 13.2: Urinary Excretion
  - 13.3: Fecal Excretion
  - 13.4: Exhaled Air
  - 13.5: Other Routes
- Section 14: Cellular Toxicology
  - 14.1: Adaptation
  - 14.2: Cell Damage and Tissue Repair
  - 14.3: Cancer
  - 14.4: Neurotoxicity
- Section 15: Intuitive Toxicology and Risk Communication
  - 15.1: Intuitive Toxicology
  - 15.2: Risk Communication
- Section 16: Environmental Toxicology, Environmental Health, and One Health
  - 16.1: Environmental Toxicology
  - 16.2: Environmental Health
  - 16.3: One Health
- Section 17: Conclusion

[Index](#)

[Glossary](#)

[Detailed Licensing](#)

## Licensing

---

A detailed breakdown of this resource's licensing can be found in [Back Matter/Detailed Licensing](#).

## Preface

---

### What is Toxicology?

Toxicology is the science of characterizing the effects of poisons (toxicants) on living organisms. It is a broad interdisciplinary scientific field which includes life sciences, chemistry, and engineering among others. Toxicologists work towards the protection of human and animal health, and of the environment.

### Why ToxMSDT?

The Toxicology Mentoring and Skills Development Training Program is a 2 yr pilot program funded by the National Institutes of Health. The goal of the program is to support educational activities that complement and/or enhance the training of a diverse workforce to meet the nation's biomedical, behavioral and clinical research needs. Toxicology is an essential component of the nation's biomedical research enterprise. However, there is a critical lack of underrepresented populations in toxicology.

Iowa State University, Tuskegee University, and the Ohio State University conceived this unique Toxicology Mentoring and Skills Development Training program targeting undergraduate underrepresented populations in order to build a pipeline entering graduate school and the toxicology workforce. Core concepts of the program are structured mentoring activities, skills development, and public outreach in toxicology.

### Nuts and Bolts of ToxMSDT

This is a one-year long toxicology mentoring and skills development training program. For the structured mentoring component, mentees are matched 1:1 with mentors primarily from industry, government, and NGOs. Mentors are trained to provide a holistic mentoring experience to mentees. Mentees shadow mentors at their places of work in addition to other face-to-face activities at Iowa State University, the annual Society of Toxicology meeting, and at Tuskegee University.

The Skills Development component consists of didactic training at the inaugural workshop held at Iowa State University, completion of six short e-modules covering core competencies of toxicologists, and knowledge gained through shadowing activities, and presentations by mentees to enhance their communication skills.

One of the challenges of recruiting undergraduates into the toxicology graduate research programs is a lack toxicology training programs and courses at the undergraduate level. Course content developed through this program are accessible to the general public. The intent is to provide content where other undergraduate students, K-12 educators, and the interested public encounter content providing an introduction to the discipline of toxicology.

## CHAPTER OVERVIEW

### 1: Pathophysiology

Pathophysiology is the study of the physical and functional changes that occur during a disease process. In this e-module you will learn about the concept of pathophysiology, types of toxicity, repair and adaptation, and patterns of toxic injury.

[1.1: What is Pathophysiology?](#)

[1.3: Outcomes of Targeted and Non-Targeted Toxicity](#)

[1.4: Cellular Response to Toxicant-Induced Injury](#)

[1.5: Repair & Adaptation](#)

[1.6: Patterns of Toxic Injury](#)

[Final Evaluation](#)

---

This page titled [1: Pathophysiology](#) is shared under a [CC BY-NC 4.0](#) license and was authored, remixed, and/or curated by [ToxMSDT Online component](#) via [source content](#) that was edited to the style and standards of the LibreTexts platform.

## 1.1: What is Pathophysiology?

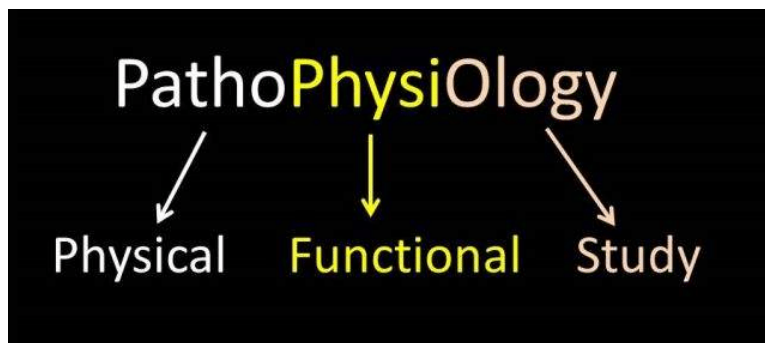

Pathophysiology describes the changes that occur during a disease process, with “patho-“ referring to the physical changes that are observed and “physio-“ referring to the functional processes or mechanisms that occur during a disease process. In toxicology, pathophysiology encompasses the biochemical and physical alterations that occur upon exposure of an individual (generally termed the “host”) to harmful amounts of a toxicant.

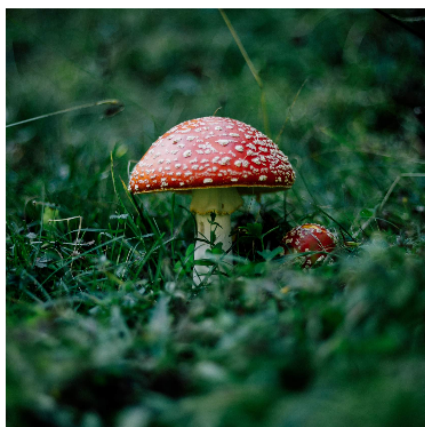

In toxicology, pathophysiology takes into account how the characteristics of the toxicant (for example, dosage, physical properties and chemical properties) and the characteristics of the host (including species, life stage, health/reproductive status, metabolism, and individual sensitivity) interact to produce physical and/or biochemical changes in the host. Pathophysiology also encompasses the host response to the effects of a toxicant. With acutely lethal intoxications, the physical and chemical injury may be sufficient to cause rapid death of the organism. In non-lethal toxic exposures, toxicant-induced injury results in dysfunction of cells, tissues and/or organs that may persist or that may progress to death. Persistent toxic injury that does not result in death generally leads to attempts at repair of toxicant-induced damage. With some toxicants, the host is able to develop strategies to adapt to continued exposure to toxicants. Dysfunction, repair and adaptive processes that occur in response to exposure to certain toxicants may trigger development of unregulated cell growth leading to tumor formation in a process termed carcinogenesis.



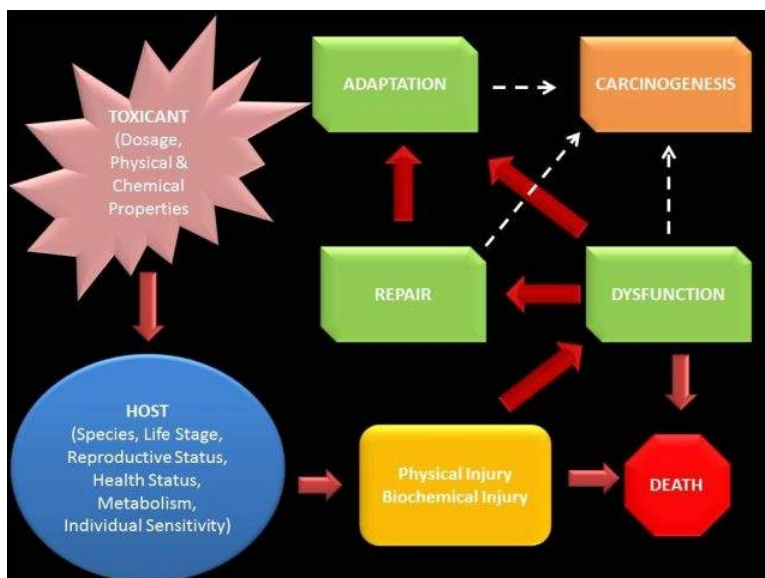

In many cases the toxicant is the unchanged xenobiotic to which the host was exposed, but in some cases the xenobiotic itself may be relatively innocuous and requires bioactivation to more toxic metabolites before toxic effects occur. A variety of endogenous systems have evolved to mitigate the effects of many toxicants and/or their metabolites. However, when these systems fail or when the dose of toxicant exceeds the capacity of the system to neutralize the toxic effects, poisoning occurs. The clinical syndrome associated with a poisoning is referred to as toxicosis.

Most toxicants exert their effects on specific molecules, tissues or organs based on the physical and chemical makeup of the toxicant as well as the absorption, distribution and metabolism of the toxicant within the body.

Toxicants such as some strong acids or alkalis (e.g. concentrated hydrochloric acid) are not systemically absorbed, so are limited to causing local injury upon contact with skin, eyes or mucous membranes. Toxicants that are ingested and absorbed from the gastrointestinal tract are shuttled via the portal vein to the liver, where they may cause direct injury, where they may be bioactivated to toxic metabolites, or where they may be detoxified before they reach the general circulation (a process termed “first pass effect”). Inhaled toxicants such as smoke may cause local tissue injury due to irritants or corrosive components as well as systemic intoxication from toxic gases such as carbon monoxide or cyanide.

#### Topic 1: Key Points

In this section, we explored the following main points:

- 1: Pathophysiology is the study of the physical and functional changes that occur during a disease process.
- 2: Toxic insults can result in physical and biochemical alterations that may lead to cellular dysfunction, repair, adaptation, carcinogenesis and/or death.

---

This page titled [1.1: What is Pathophysiology?](#) is shared under a [CC BY-NC 4.0](#) license and was authored, remixed, and/or curated by [ToxMSDT Online component](#) via [source content](#) that was edited to the style and standards of the LibreTexts platform.

## 1.3: Outcomes of Targeted and Non-Targeted Toxicity

### Learning Objectives

After completing this lesson, you will be able to:

- 1: Discuss the various effects that toxicants have on target molecules and how these effects result in injury to the host.
- 2: Discuss the pathogenesis of the rash that occurs following exposure to poison ivy.

The interaction of toxicants with host molecules may lead to the dysfunction or destruction of the target molecule, or it may result in formation of adducts that the immune system identifies as “foreign,” triggering immune responses against these neoantigens.

### Target Molecule Dysfunction

Target molecule dysfunction is a common mechanism by which xenobiotics, particularly drugs, exert their effects; remember it is the dose of xenobiotic that determines whether the effect will be therapeutic (pharmacologic) or harmful (toxicologic). Target molecule dysfunction may occur through activation of cellular membrane receptors, resulting in over-stimulation of some cellular function. For instance, the toxic effects of methomyl, a carbamate insecticide, include over-stimulation of cells of excretory glands, resulting in excessive salivation, excessive tear formation and excessive secretion of mucus by goblet cells within the respiratory tract.

Conversely, other toxicants may inhibit or impede the action of cellular receptors; the resulting clinical effects will depend on the type of receptor affected and what action is impeded. For example, there are channels in nerve cell membranes that allow sodium to pass into and out of the cell; when exposed to pyrethrins, insecticides extracted from chrysanthemum flowers, these channels are unable to close, which results in excessive stimulation seen as muscle twitches, tremors and convulsions. However, when these channels are exposed to tetrodotoxin, the infamous puffer fish toxin, these channels are unable to open, which prevents stimulation of muscle and results in paralysis.



Figure 1.3.1: Pufferfish (fugu) is a delicacy in some countries, but if not prepared correctly it can cause paralysis and even death.

Toxicants may induce target molecule dysfunction by altering protein structure such that the protein is no longer functional, resulting in disruption of membrane protein channels, interference with transmembrane signaling or loss of enzyme function. Many of these types of effects involve the toxicant or its metabolite binding to reactive moieties on the protein molecule; the sulfhydryl or thiol (S-H) moiety is particularly susceptible to binding with other reactive compounds. Toxicant-induced alteration of DNA structure can lead to mispairing of nucleotides during mitosis, with potential effects ranging from altered protein synthesis to initiation of carcinogenesis.



Figure 1.3.2: DNA strand breaks may result in cell death, genetic mutation or development of cancers

Neoantigen formation results when a xenobiotic or its metabolite **binds** to a larger protein to form a novel molecule that elicits an immune response. Molecules that trigger an immune response upon binding to carrier proteins are termed **haptens**, and the process

of neoantigen formation in this manner is termed **haptimization**. Neoantigens can trigger humoral immune responses resulting in the development of antibodies that can trigger acute **allergic** reactions such as hives or anaphylaxis. Neoantigens that trigger cellular-mediated immune responses cause injury to specific tissues or organs such as skin, liver or blood vessels in a process termed **autoimmunity**.

### DID YOU KNOW?

The rash caused by poison ivy (*Toxicodendron* spp.) is caused by urushiol, an oily mixture of chemicals called catechols, in the sap of the plant. Upon exposure to human skin, urushiols bind to membranes on skin cells and serve as haptens, changing the shape of proteins in the membranes. The body's immune cells no longer recognize these skin cells as normal parts of the body and mount an immune response, resulting in inflammation, itching, blisters, swelling and redness at the site of urushiol contact. In addition to local irritation, serious, systemic reactions to urushiol can occur if the leaves are ingested, or if smoke from burning poison ivy is inhaled.



Figure 1.3.3: Skin contact with leaves of poison ivy can result in a blistering rash.

### Topic 3: Key Points

In this section, we explored the following main points:

- 1: Toxicant-induced target molecule dysfunction can occur through activation or inhibition of cellular receptors, denaturing of membrane proteins, and destruction of target molecules.
- 2: Haptimization results in the formation of neoantigens that can trigger immune responses against cells and tissues of the body, resulting in allergic or autoimmune reactions.
  - The rash caused by poison ivy is an autoimmune reaction against skin cells whose membranes have bound to the toxicant urushiol from the plant.

### ? Knowledge Check

1. On a protein molecule highly reactive toxicant molecules have a predilection for\_\_\_\_\_.

sulfhydryl (S-H) moiety

Haptimization

dose

#### Answer

sulfhydryl (S-H) moiety

2. The therapeutic or toxic effect of a xenobiotic is entirely dependent on its\_\_\_\_\_.

sulfhydryl (S-H) moiety

Haptimization

dose

#### Answer

dose

3. A xenobiotic binding a larger protein molecule, resulting in an immune response.

sulfhydryl (S-H) moiety

Haptimization

dose

#### Answer

Haptimization

This page titled [1.3: Outcomes of Targeted and Non-Targeted Toxicity](#) is shared under a [CC BY-NC 4.0](#) license and was authored, remixed, and/or curated by [ToxMSDT Online component](#) via [source content](#) that was edited to the style and standards of the LibreTexts platform.

## 1.4: Cellular Response to Toxicant-Induced Injury

### Learning Objectives

After completing this lesson, you will be able to:

- 1: Describe the range of cellular injury that may occur following exposure to a toxicant.
- 2: Discuss the major mechanisms of toxicant-induced cell death.
- 3: Compare the processes of necrosis and apoptosis in terms of inciting causes and the cellular changes that occur with each.

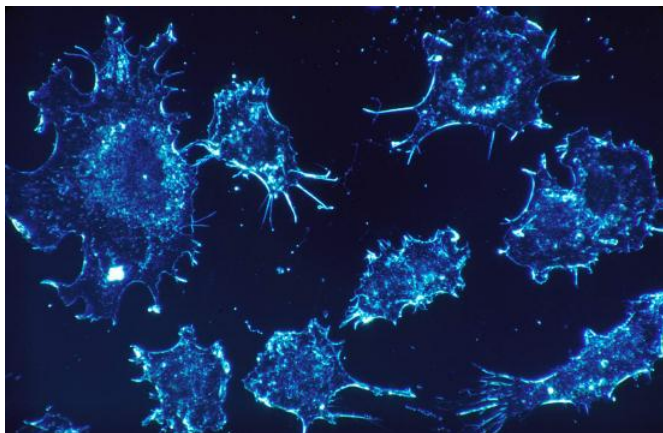

Toxicants can exert a variety of effects at the molecular level that have significant repercussions at the cellular, tissue and organ levels. The effects of a toxic exposure can range from reversible cellular dysfunction to irreversible cellular injury to cell death, all of which can alter normal organ function and have significant impact on the health and well-being of the body as a whole. The ability of cells, tissues and organs to overcome the effect of a toxicant through repair and/or adaptation will dictate the ultimate outcome of a toxic exposure.

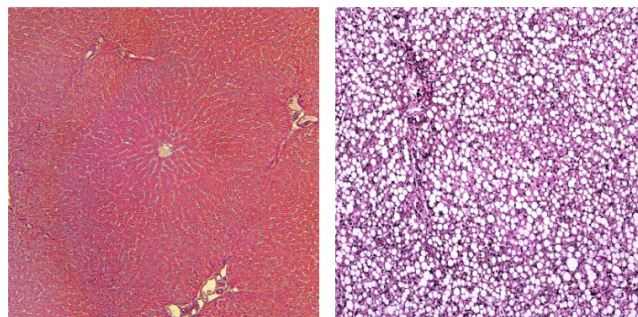
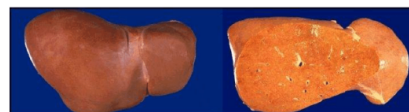

Figure 1.4.1: Lipid accumulation in the liver comparing normal liver (left) to liver with steatosis (center). In the photomicrographs at the right, the white spaces are areas of lipid accumulation.

Following toxic insult, cells have a limited repertoire of responses. Nonlethal cell injury may lead to cellular degeneration, seen microscopically as swelling of the cells. Toxicant-injured cells may accumulate water, lipid, pigments, glycogen or metabolic waste products due to impairment of normal maintenance functions. Accumulation of lipids in hepatocytes, termed **steatosis** or **hepatic lipidosis**, is a common toxic effect seen in cases of alcohol-related liver disease. Degenerative changes in cells are often reversible if the inciting cause is removed. When cell injury proceeds beyond the self-repair capability of the cell, cell death ensues.

## Mechanisms of Cell Death

Major mechanisms of toxicant-induced cell death include disruption of cell membrane structure and/or function, loss of cellular maintenance functions, and impairment of cellular energy production. Loss of membrane structural or functional integrity can result in uncontrolled passage of water, ions and other compounds into or out of the cell. The subsequent loss of normal cytosolic environment interferes with normal biochemical processes necessary for cell function and/or survival. Loss of ability to synthesize proteins and other macromolecules impedes maintenance of organelles and enzymatic pathways vital to cellular survival. Impairment of cellular energy production generally occurs when toxic effects alter mitochondrial function and/or structure and can lead to cell death due to failure to produce sufficient ATP to power essential cellular functions.

### Necrosis

**Necrosis** is the term used to describe cell death due to irreversible injury. Necrotic cells undergo degenerative processes including swelling of organelles, loss of organelle function, oxidative and hydrolytic degradation of intracellular membranes and macromolecules by electrophiles and free radicals, and, ultimately, **lysis** (loss of cellular constituents to surrounding tissues due to cell membrane rupture). Necrosis generally results in the generation of an inflammatory response as cellular components and free radicals that are released to the extracellular matrix attract inflammatory cells.

### Apoptosis

In contrast, **apoptosis** (sometimes nicknamed “cell suicide” or “programmed cell death”) is a more orderly form of cell death. Apoptosis is an active process involving activation of specific enzymes which triggers the systematic fragmentation of cell constituents into blebs of cell membrane that pinch off of the main cell to form **apoptotic bodies**. During this fragmentation, the cell continues to produce energy and proteins, unlike necrosis where organelle and energy production cease prior to cellular fragmentation. The end result of apoptosis is numerous apoptotic bodies, each composed of a cellular membrane surrounding intact and functional cellular components. Apoptosis can be triggered by various forms of oxidative stress, particularly the presence of excessive oxygen-derived free radicals, due to excessive free radical generation and/or to lack or exhaustion of endogenous antioxidants. Because intracellular components are not spilled into the extracellular matrix, apoptosis generally does not incite an inflammatory response; instead the apoptotic bodies are removed by local phagocytes.

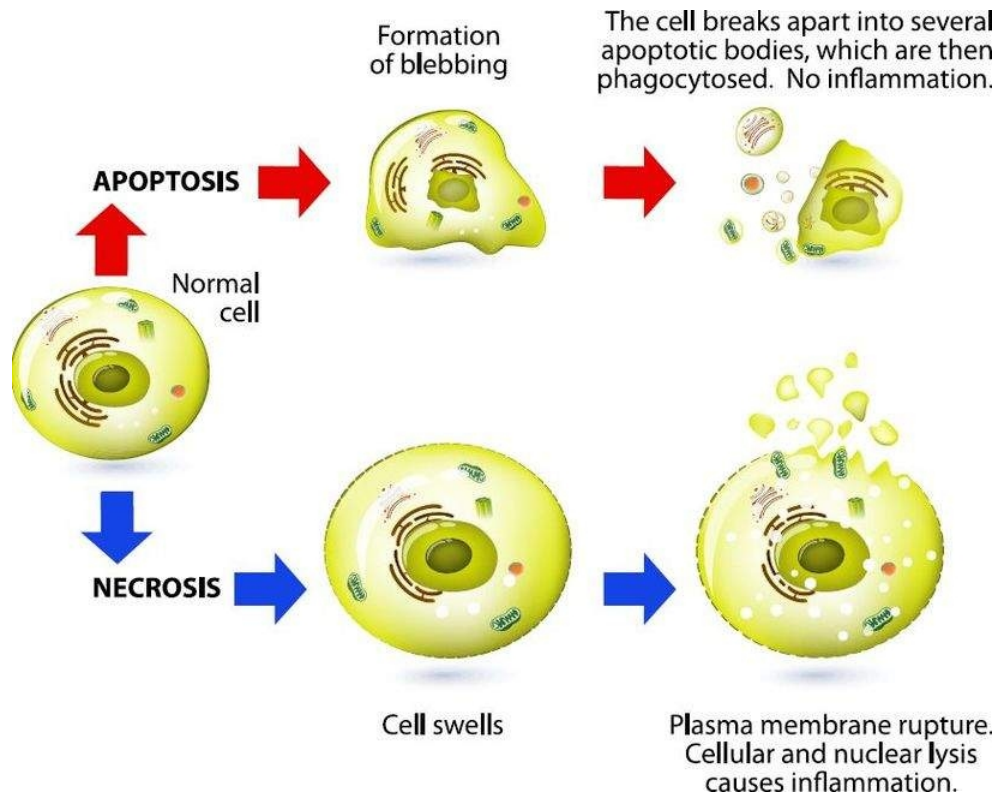

Figure 1.4.2: Apoptosis and Necrosis are two very different forms of cell death.



#### Topic 4: Key Points

In this section, we explored the following main points:

- 1: Toxicant-induced cellular injury can range from reversible cellular dysfunction to irreversible cellular injury to cell death.
- 2: Cellular responses to toxic injury may include cellular degeneration and accumulation of substrates within the cell.
  - Steatosis is lipid accumulation within hepatocytes and is a common toxic effect secondary to alcohol exposure.
- 3: Major mechanisms of cell death include disruption of cell membrane structure and/or function, loss of cellular maintenance functions, and impairment of cellular energy production.
- 4: Necrosis is cell death resulting from cessation of organelle function, degradation of intracellular structures and culminating in lysis of the cell and attraction of inflammatory cells.
- 5: Apoptosis is an active form of cell death whereby cellular function is maintained as the cell components are compartmentalized and packaged into apoptotic bodies that pinch off of the main cell.
  - Apoptosis can be triggered by oxidative stresses caused by oxygen-derived free radicals.
  - Apoptosis is not generally associated with an inflammatory response.

#### Knowledge Check

1. The accumulation of excess lipid within liver cells:

**Answer**

Steatosis

2. Cellular degeneration secondary to a toxic insult is seen microscopically as:

**Answer**

Cellular Swelling

3. Loss of organelle function, hydrolytic degradation of intracellular membranes and lysis of cells are characteristics of\_\_\_\_\_.

**Answer**

*necrosis*

4. The orderly decommissioning of cellular organelles without loss of energy and protein synthesis leading to fragmentation into membrane-bound packets is characteristic of\_\_\_\_\_.

**Answer**

*apoptosis*

This page titled [1.4: Cellular Response to Toxicant-Induced Injury](#) is shared under a [CC BY-NC 4.0](#) license and was authored, remixed, and/or curated by [ToxMSDT Online component](#) via [source content](#) that was edited to the style and standards of the LibreTexts platform.

## 1.5: Repair & Adaptation

### Learning Objectives

After completing this lesson, you will be able to:

1. Explain cell and tissue repair mechanisms and how toxicants may alter these processes.
2. Discuss adaptation mechanisms that may occur with exposures to toxicants.

### Repair

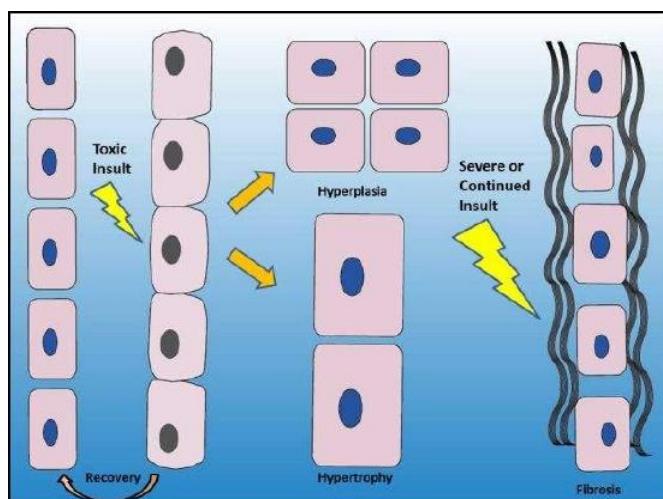

The ability of cells to repair toxicant-induced damage plays a large role in the outcome of exposure to toxicants. Repair mechanisms include molecular repair such as reversal of thiol oxidation, removal of damaged units with replacement by newly synthesized units, and degradation followed by resynthesis of damaged structures. Cellular repair mechanisms include autophagy of damaged organelles and resynthesis/regeneration of damaged structures. Tissue repair mechanisms include active removal of damaged cells via apoptosis, regeneration of cells by **hyperplasia** (increase in cell numbers) or **hypertrophy** (increase in cell size), and resynthesis of extracellular matrix. When cellular or tissue repair is unable to restore original tissue architecture, production of extracellular connective tissue results in **fibrosis**.

Some toxicants can interfere with the normal cellular repair mechanisms, resulting in early cellular senescence and death. Inability to repair damage to DNA can result in disruption of normal protein synthesis or initiation of carcinogenesis. Other toxicants trigger exaggerated repair mechanisms which themselves pose a hazard to the survival of the individual. For instance, the herbicide paraquat causes lung injury mediated by oxygen-derived free radicals; because the lung is a highly oxygenated organ, this damage can be quite extensive as the ready availability of oxygen provides plenty of fuel for the snowballing generation of free radicals such as superoxide anions. The immediate effect of paraquat on the lung is damage to alveolar walls, resulting in stimulation repair mechanisms that cause intense, progressive fibrosis of the lung over several weeks, which ultimately leads to the death of the patient from asphyxia. Intense fibrosis is also seen in alcoholic cirrhosis of the liver, with normal liver parenchyma being replaced by fibrous connective tissue that impedes normal liver function.

### ADAPTATION



Adaptation mechanisms have evolved at the cellular, tissue and organ levels that allow the individual to survive in the face of exposure to levels of toxicants that might otherwise result in serious or lethal injury. Adaptation requires time to develop, so generally occurs upon multiple exposures to levels of toxicants that are too low to cause severe acute injury. Adaptation mechanisms include alteration of toxicant delivery to target sites, decreasing reactivity of the target site to the toxicant, increasing local repair mechanisms, and development of compensatory mechanisms to mitigate toxicant-induced injury.

Decreasing toxicant delivery to target site may include decreasing toxicant absorption, detoxification of the toxicant before it can reach the target site, or binding of the toxicant with a neutral molecule. The opioid fentanyl is a powerful narcotic when injected, but it is quickly metabolized in the liver if ingested, greatly reducing the amount that enters the systemic circulation and reaches the central nervous system; this “first pass effect” occurs with many substances and is often the reason why some drugs must be administered via injection rather than the oral route.



Similarly, chronic ingestion of ethyl alcohol can result in the **induction** (increased expression) of the enzyme alcohol dehydrogenase in the gastrointestinal tract and liver, resulting in more alcohol being metabolized before it can reach the systemic circulation.

Some toxic heavy metals that reach the bloodstream become bound to metal-binding proteins called **metallothioneins**; because only unbound metals are free to react, metallothioneins prevent the toxic metals from interacting with their target sites. Many sea-dwelling mammals such as killer whales (*Orca* spp.) bind organic mercury to selenium-containing metallothioneins which allows them to accumulate large amounts of organic mercury that would be lethal to terrestrial mammals.

Adaptation by decreased reactivity to the target site is classically illustrated by the **tolerance** that can develop in people addicted to opioids such as heroin. Constant stimulation of opioid receptors results in **downregulation** (decreased expression) of those receptors and increased amounts of opioids required to stimulate remaining receptors.

Adaptive mechanisms may include increased function or number of cells to compensate for the loss of function of similar cells due to toxic insult. A variety of toxicants can cause injury to kidney tubules, and as a result, other kidney tubules may undergo hypertrophy and/or hyperplasia in an attempt to provide adequate kidney function.

Adaptive and repair mechanisms frequently occur simultaneously, resulting in characteristic lesions in some organs or tissues, For example, toxic hepatocellular injury from chronic alcohol exposure may result in nodular areas of regenerating hepatocytes (adaptation) surrounded by fibrous connective tissue formed to replace lost hepatocytes (repair), resulting in the characteristic “bubbly” look of hepatic cirrhosis.

### Topic 5: Key Points

In this section, we explored the following main points:

- 1: Tissue repair mechanisms include removal of damaged cells via apoptosis, regeneration of cells by hyperplasia (increase in cell numbers) or hypertrophy (increase in cell size), and regeneration of extracellular matrix.
  - Fibrosis may result when tissue repair is incomplete.
- 2: Adaptation mechanisms may allow the host to survive in the face of continuous exposure to toxicants and include:
  - alteration of toxicant delivery to target sites.
  - decreasing reactivity of target site to toxicant
  - increasing local repair processes
  - compensatory mechanisms to mitigate toxicant-induced injury

#### Knowledge Check

1. An example of decreasing the reactivity of a target site to a toxicant

#### Answer

Downregulation of toxicant receptors

2. A regenerative response that results in an increased number of cells being produced

#### Answer

Hyperplasia

This page titled [1.5: Repair & Adaptation](#) is shared under a [CC BY-NC 4.0](#) license and was authored, remixed, and/or curated by [ToxMSDT Online component](#) via [source content](#) that was edited to the style and standards of the LibreTexts platform.

## 1.6: Patterns of Toxic Injury

### Learning Objectives

- 1: Explain how the structure and function of the liver relates to its susceptibility and responses to toxicants.
- 2: Discuss how the pattern of toxic injury seen in an organ may provide clues to the toxicant that is involved.



Toxicants can exert their effects systemically or by altering target tissues or organs, and sometimes the patterns of injury left behind can aid in the identification of an unknown toxicant, or at least allow the list of suspects to be narrowed down to a smaller number than the thousands of potential toxicants that exist. Because most absorbed toxicants are carried in the bloodstream, blood flow patterns often dictate which tissues may be affected. Within the tissues, variations in cell type and function can also influence the pattern of injury that can be seen with a given toxicant. Because they receive high volumes of blood flow, and because of their roles in metabolism and excretion of xenobiotics, the liver and kidney are particularly vulnerable to effect from systemically absorbed toxicants.

### Patterns of Hepatic Injury

The microscopic appearance of the liver is that of a hexagonal lobule. Blood enters the parenchyma from the hepatic artery and portal vein situated, along with a bile duct, at an area termed the **portal triad** situated at each of the six vertices of the lobule (**periportal** regions). From the triad region, the blood passes through endothelial-lined **sinusoids** that separate anastomosing sheets of hepatocytes before exiting via the terminal hepatic, or **central vein** (**centrilobular** region). Physiologically, the liver has highly oxygenated blood entering at **zone 1**, which is roughly equivalent to the periportal areas, surrendering its oxygen as it filters through the sinusoids, and reaching **zone 3** (centrilobular region) as poorly oxygenated blood that exits via the central vein. **Zone 2**, also called the **midzonal** region, is the intermediate area between zones 1 and 3.

# STRUCTURE OF LIVER LOBULE

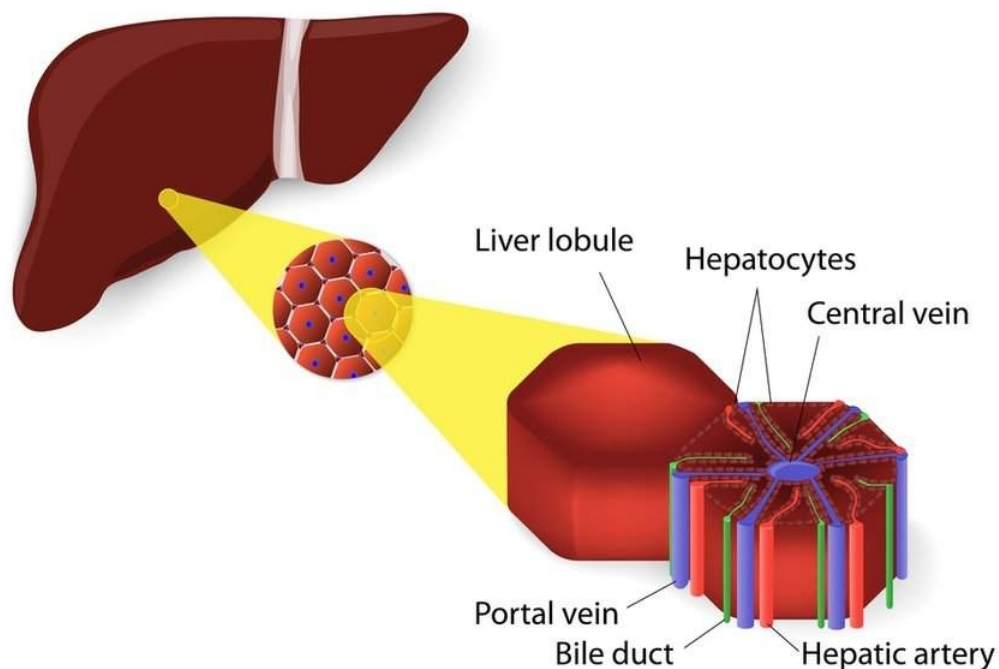

Within the different zones of the liver, hepatocytes vary in their physiologic functions, with those in zone 1 being more efficient in oxidative metabolism and zone 3 hepatocytes being efficient at xenobiotic biotransformation. Hepatocytes in zone 1 are the first to be exposed to toxicants that enter the liver; if those toxicants are directly injurious to hepatocytes (e.g. white phosphorus), the pattern of cell injury will be periportal. Toxicants requiring bioactivation to cause injury (e.g. acetaminophen) will generally cause zone 3 (centrilobular) hepatic injury, since this area contains higher levels of biotransforming enzymes. This area is also at risk for hypoxic injury due to toxicants that alter oxygen delivery to cells (e.g. carbon monoxide). Because of these vulnerabilities, centrilobular injury is the most common form of toxicant-induced hepatic injury. **Massive** liver necrosis affects entire hepatic lobules, and has been associated with exposure to a variety of toxicants including acetaminophen, aflatoxin, blue-green algae, and hepatotoxic mushrooms. **Piecemeal** necrosis is a less commonly seen form of liver injury wherein scattered individual hepatocyte necrosis or apoptosis occurs along the limiting plate between portal triads; this form of hepatic injury has been associated with immune-mediated processes such as is seen with non-steroidal anti-inflammatory drug-induced hepatopathy.

Zone 1 (Periportal)	Zone 2 (Midzonal)	Zone 3 (Centrilobular)
Iron Salts	Furans	Acetaminophen
White Phosphorus	Ngaione ( <i>Myoporium</i> spp.)	Aflatoxin
	Beryllium	Microcystin (Blue-Green Algae)
		Ricin (Castor Bean)

## Patterns of Renal Injury

The nephron is the functional unit of the kidney, consisting of the renal corpuscle (**Bowman's capsule** and **glomerulus**), **proximal tubule**, **loop of Henle**, and **distal tubules**. Toxicants that are directly injurious may cause damage to the glomerular structures or to the anterior portion of the proximal tubule. Toxicants that require bioactivation generally cause injury to the more distal section of the proximal renal tubules, as this is where the majority of biotransforming enzymes occur. As the glomerular filtrate passes

through the loop of Henle and distal tubules and becomes more concentrated, toxicants that were too dilute to affect earlier renal structures may cause injury in these more distal sections of the kidney. Toxicants that decrease renal blood flow (e.g. non-steroidal anti-inflammatory drugs) can also cause injury to more distal tubules, collecting ducts and renal papillae as these regions receive less blood flow than more proximal structures.

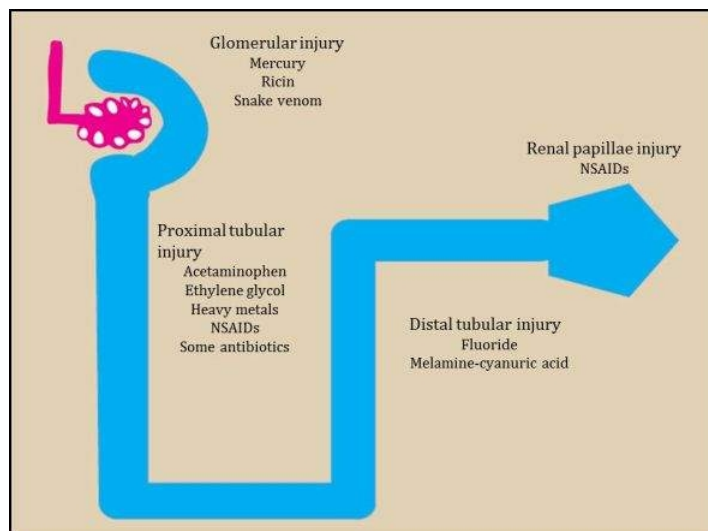

### Topic 6: Key Points

In this section, we explored the following main points:

- 1: Toxic injury to a tissue or organ will depend largely on the pattern of blood flow to that tissue or organ.
  - Cells in areas that normally have low oxygenation are at increased risk of injury from toxicants that reduce blood flow or oxygen delivery.
- 2: Variations in cell type and function can affect the pattern of toxicant-induced injury.
  - Cells with large capacity for metabolism of xenobiotics will be at higher risk for injury by toxicants requiring bioactivation.
- 3: Identification of the pattern of toxicant-induced injury can provide clues to the types of toxicants that may have caused the injury.

### 📌 Knowledge Check

1. Which of the following patterns of injury would be consistent with a toxicant that is directly injurious to liver and kidney cells?

- Centrilobular hepatic injury, distal tubular renal injury
- Centrilobular hepatic injury, proximal tubular renal injury
- Periportal hepatic injury, distal tubular renal injury
- Periportal hepatic injury, proximal tubular renal injury

#### Answer

Periportal hepatic injury, proximal tubular renal injury

2. Which features make the centrilobular region of the liver lobule more susceptible to toxic insult?

- Relatively low levels of biotransformation enzymes and relatively low oxygenation
- Relatively high levels of biotransformation enzymes and relatively low oxygenation
- Relatively low levels of biotransformation enzymes and relatively high oxygenation
- Relatively high levels of biotransformation enzymes and relatively high oxygenation

**Answer**

Relatively high levels of biotransformation enzymes and relatively low oxygenation

---

This page titled [1.6: Patterns of Toxic Injury](#) is shared under a [CC BY-NC 4.0](#) license and was authored, remixed, and/or curated by [ToxMSDT Online component](#) via [source content](#) that was edited to the style and standards of the LibreTexts platform.

## Final Evaluation

---

1. General rule of thumb for apoptosis is that it is more commonly seen at higher levels of toxicant exposure while necrosis occurs more frequently at relatively lower levels of toxicant exposure. *True or False?*

True

False

**Answer**

False

2. Neoantigen formation results when a xenobiotic or its metabolite binds to a larger protein to form a novel molecule that elicits an immune response. Molecules that trigger this immune response are called:

Haptens

Free radicals

Electrophils

Poisons

**Answer**

Haptens

3. Lipid peroxidation occurs when an \_\_\_\_\_ compound steals an electron from a membrane phospholipids resulting in the production of a fatty acid radical.

Electrophobic

Hydroxyl radical

Electrophilic

Hydrophilic

**Answer**

Electrophilic

4. Electron transfer can result in oxidation of some endogenous macromolecules and formation of \_\_\_\_\_ such as superoxide ion ( $\bullet\text{O}_2^-$ ) and hydroxyl radical ( $\text{HO}\bullet$ ).

Enzymes

Hormones

Free radicals

Proteins

**Answer**

Free radicals

5. Upon exposure of human skin with leaves of poison ivy, the toxin found in this plant binds to membranes on skin cells to stimulate an immune response resulting in blistering rash. This toxin is known as:

Urushiol

Ricin

Tetrodotoxin

Pyrethrins

**Answer**

Urushiol

**6. Which of the following covalently binds to the acetaminophen metabolite N-Acetyl-P-Benzoquinone Imine (NAPQI) to detoxify it?**

- N-acetylcysteine
- Superoxide dismutase
- Catalase
- Amylase

**Answer**

N-acetylcysteine

**7. Differences between Necrosis and Apoptosis include the following EXCEPT:**

- Necrosis is a degenerative process while Apoptosis is an active process
- Necrosis triggers inflammatory response while Apoptosis does not incite inflammatory response
- Necrosis results in loss of energy while Apoptosis does not result in loss of energy
- Necrosis is an active process while Apoptosis is a degenerative process

**Answer**

Necrosis is an active process while Apoptosis is a degenerative process

**8. A regenerative response that results in an increase in cell size is termed \_\_\_\_\_.**

- Hypertrophy
- Hypoplasia
- Hyperplasia
- Atrophy

**Answer**

Hypertrophy

**9. \_\_\_\_\_ helps to terminate lipid peroxidation when present in sufficient quantities.**

- Vitamin E
- Hydroxyl radical
- Vitamin A
- Oxygen

**Answer**

Vitamin E

**10. An “adduct” is the product of an irreversible bond between the toxicant and target molecule; this type of binding is known as:**

- Noncovalent binding
- Covalent binding
- Hydrogen abstraction
- Ionic binding

**Answer**

Covalent binding

**11. An example of decreasing the reactivity of a target site to a toxicant is describe as:**

- Binding of toxicant to target receptors
- Downregulation of toxicant target receptors
- Increased metabolism of alcohol within the stomach and liver
- Stimulation of membrane receptors

**Answer**

Downregulation of toxicant target receptors

**12. 10% of acetaminophen bioactivated by Cytochrome P450 in the liver to a toxic metabolite is called:**

- Superoxide dismutase
- N-acetylcysteine
- N-acetyl-P-Benzoquinone Imine (NAPQ1)
- Superoxide ion

**Answer**

N-acetyl-P-Benzoquinone Imine (NAPQ1)

---

This page titled [Final Evaluation](#) is shared under a [CC BY-NC 4.0](#) license and was authored, remixed, and/or curated by [ToxMSDT Online component](#) via [source content](#) that was edited to the style and standards of the LibreTexts platform.



## CHAPTER OVERVIEW

### 2: Biochemistry and Molecular Genetics

Biochemistry is the study of chemical processes within and related to living organisms. In this e-module you will learn about biomolecules and cell components, cell structure and subcellular compartments, DNA and RNA metabolism, and epigenetic mechanisms.

[2.1: Introduction to Biomolecules and Cell Components](#)

[2.2: Cell Structure and Subcellular Compartments](#)

[2.3: DNA and RNA Metabolism](#)

[2.4: Epigenetic Mechanisms](#)

[Section 2 Final Evaluation](#)

---

This page titled [2: Biochemistry and Molecular Genetics](#) is shared under a [CC BY-NC 4.0](#) license and was authored, remixed, and/or curated by [ToxMSDT Online component](#) via [source content](#) that was edited to the style and standards of the LibreTexts platform.

## 2.1: Introduction to Biomolecules and Cell Components

### Learning Objectives

- 1: Define the basic structure of biomolecules, such as: amino acids and proteins, carbohydrates, fatty acids, triacylglycerol, phospholipids, steroids and nucleic acids.
- 2: Define the meaning and significance of essential and non-essential amino acids.
- 3: Understand the function of enzymes.
- 4: Define the basic structure of ribonucleic acid (RNA) and deoxyribonucleic acid (DNA).

### 1.1

#### Amino Acids and Proteins

Amino acids are the basic units of proteins. All amino acids present in proteins carry a carboxyl- and an amino group, hydrogen and variable side chains (R) at a single  $\alpha$  – carbon atom.

##### Amino Acid Basic Structure:

Every amino acid has four components linked together with a central carbon atom  $\alpha$  – carbon:

- **Amino group (NH<sub>2</sub>)**
- **Carboxylic acid group (COOH)**
- **Hydrogen atom (H)**
- **R-group, which varies with each amino acid (R)**

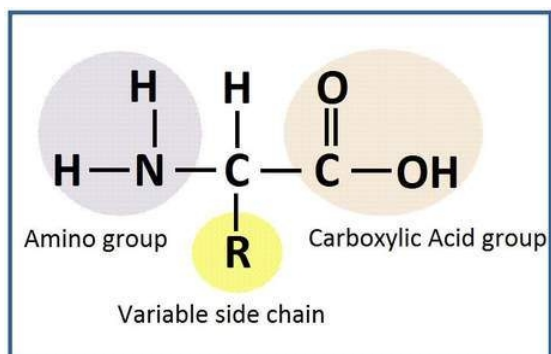

Figure 2.1.1: Basic structure of an amino acid. Credit: Aline de Conti

##### R groups may be:

- Hydrophobic
- Hydrophilic
- Charged R-groups: *positive or negative charged*
- Special R-groups: *conjugated with other molecules*

##### Amino Acids are classified into two groups.

**Essential:** Humans cannot synthesize them and must be obtained directly from food (phenylalanine, valine, threonine, tryptophan, methionine, leucine, isoleucine, lysine, histidine, cysteine, and arginine).

**Non-essential:** The human body is able to produce them (glycine, alanine, serine, asparagine, glutamine, tyrosine, aspartic acid, glutamic acid, and proline).

Below, you can see different structures of the most common amino acids in humans. Amino acids link together, in a reaction known as **peptide bond**, to form proteins.

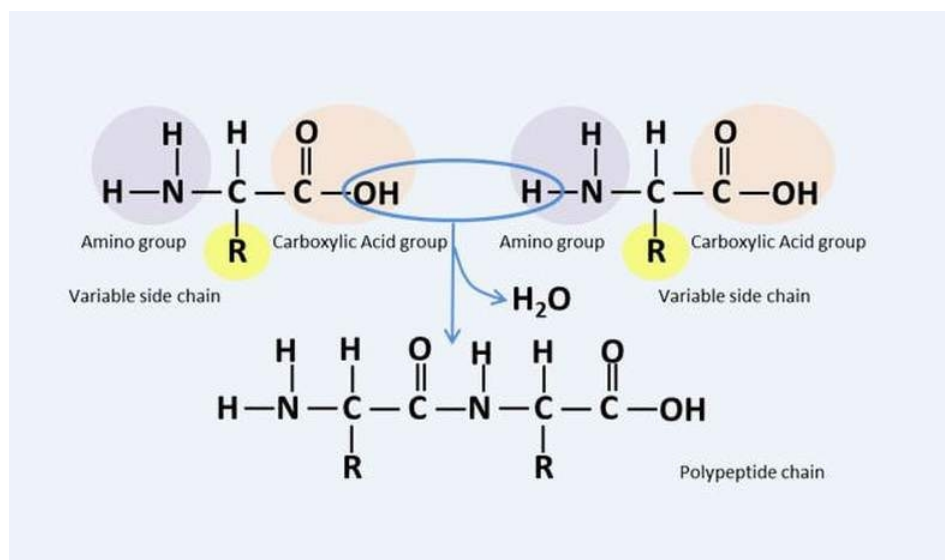
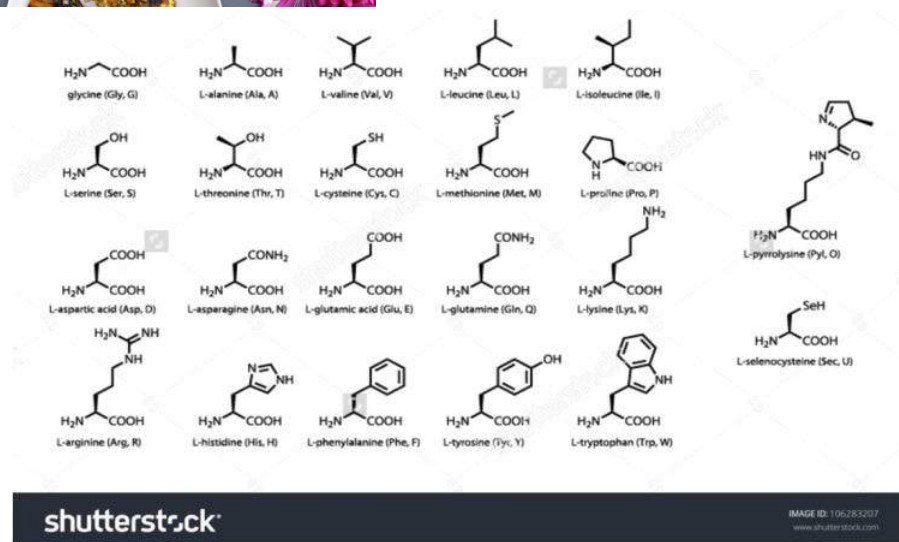
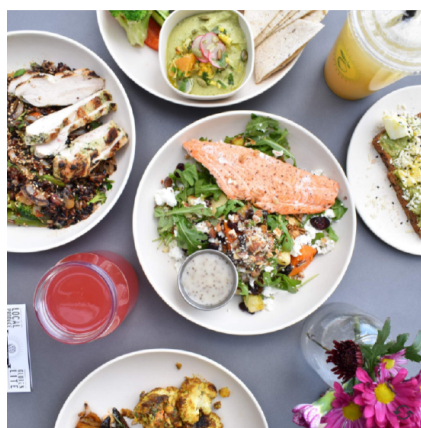

Figure 2.1.2: Peptide bond. Credit: Aline de Conti

## Levels of Protein Structure

### Primary (1°) Structure

The sequence of amino acids in a protein is named as **primary structure**. The amino acids are linked via peptide bonds formed with the carboxylic acid group of one amino acid and the amino group of a other amino acid.

## Secondary (2°) Structure

The secondary structure is the way a polypeptide folds to form  **$\alpha$ -helix**,  **$\beta$ -strand**, or  **$\beta$ -turn**.

## Tertiary (3°) Structure

The tertiary structure is the way the polypeptide chain coils and turns to form a complex molecular shape. Additionally, tertiary structure starts to develop an active sites of proteins where critical actions and interactions will take place.

## Quaternary (4°) Structure

The quaternary structure is the combination of the multiple protein subunits that interact to form a single, larger, biologically active protein.

## Protein Functions

Proteins have several functions in the human body including hormonal, enzymes, structural proteins in cell membranes, proteins also receive signals from outside the cell and mobilize intracellular response, and they are part of the immune system.

Enzymes are specialized proteins that accelerate a chemical reaction by serving as a biological catalyst. By catalyzing these reactions, enzymes cause them to take place one million or more times faster than in their absence. Several biochemical reactions important for cellular maintenance occur due to enzymes activity. For example: environmental response and metabolic pathways.

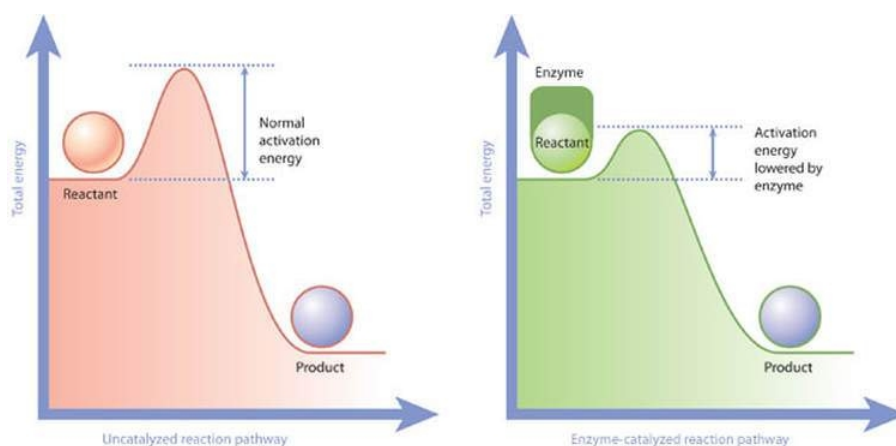
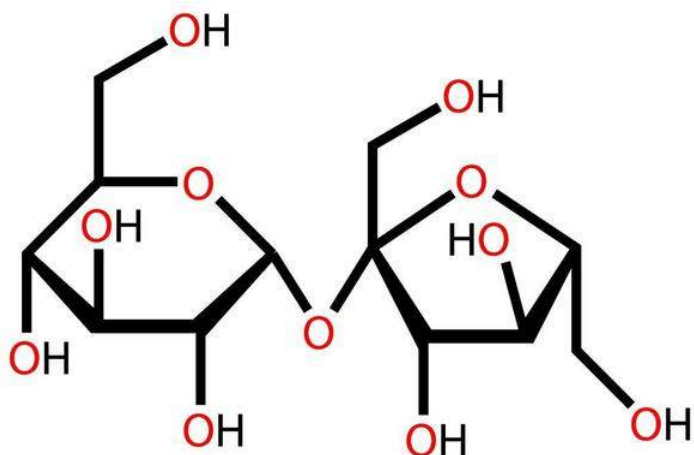

Figure 2.1.3: Enzymes and Activation Energy - © 2010 Nature Education

## 1.2

### Carbohydrates



Carbohydrates are made of molecules of carbon (C), Hydrogen (H) and Oxygen (O), and are composed of recurring monomers called monosaccharides (which typically form ring structures). A common name of monomers and dimers is 'sugar'.

Carbohydrates are classified into three subtypes.



**1. Monosaccharides:** 1 unit of monomer. Examples: fructose, glucose, galactose.

Present in fruits, etc.

**2. Disaccharides:** 2 units of monosaccharides. Examples: lactose, maltose, sucrose.

Present in milk, etc.

**3. Polysaccharides:** Many monosaccharide units. Examples: cellulose, glycogen, starch.

Present in breads, grass, etc.

Carbohydrates are a group of macromolecules that are important energy source required for various metabolic activities. Carbohydrates may bind to proteins and lipids that play important roles in cell interactions e.g. receptor molecules and immune system e.g. antigens.



# Carbohydrates

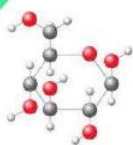

Glucose

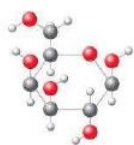

Galactose



Fructose

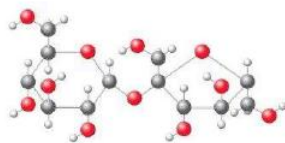

Sucrose

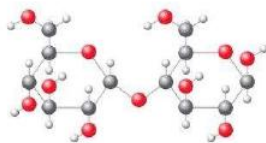

Maltose

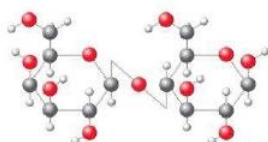

Lactose

## 1.3

### Lipids

Lipid molecules are mainly hydrophobic molecules i.e. found in areas away from water molecules, but also present smaller hydrophilic parts that are important for its biological function. The major roles of lipid molecules are to serve as storage of biological energy (Example: **triacylglycerols**) and provide the building blocks for biological membranes (Example: **phospholipids** and **cholesterol**). Although there are other types of lipids, in this topic we will discuss the structure and function of these main groups of lipids.

#### Triacylglycerols

Triacylglycerols are composed of fatty acids and glycerol.

- **Glycerol** is a simple three-carbon molecule with hydroxyl groups at each carbon.
- **Fatty acids** are chains of carbon molecules with a carboxylic acid (COOH) in the first carbon and a CH<sub>3</sub> (methyl) group at the end of the chain.



#### Fatty acids can be...

**Saturated:** Fatty acids contain only single carbon-carbon bonds, and all of the carbon molecules are bonded to the maximum number of hydrogen molecules.

**Unsaturated:** Fatty acids have at least one double carbon-carbon bond with the potential for additional hydrogen atom bonding still existing for some of the carbon atoms in the backbone chain. If more than one double bond is present, the term polyunsaturated is used.

### Essential Fatty Acids

Examples of two essential fatty acids, linoleic acid (known as **omega-6;ω-6**) and linolenic acid (known as **omega-3; ω-3**). These fatty acids present double bonds at the sixth and third carbon atoms, respectively, counting from the methyl end of their chains. They are considered essential because humans do not have the ability to produce double bonds at these locations and, therefore, must obtain these two fatty acid from vegetable oils.

linoleic acid (omega-6 fatty acid)

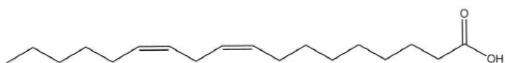

alpha-linolenic acid (omega-3 fatty acid)

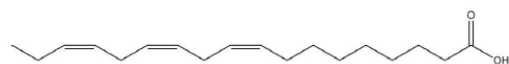

### Phospholipids

Phospholipids are the major component of cell membranes. They form lipid bilayers because of their amphiphilic characteristic.

The structure of the **phospholipid** molecule generally consists of two hydrophobic fatty acid "tails" and a hydrophilic "head" consisting of a phosphate group ( $\text{PO}_4^{3-}$ ) attached to the third glycerol carbon. This head group is usually charged, creating a part of the lipid that is hydrophilic, and wants to be near water, a quality that is essential for the formation of biological membranes and many lipid functions.

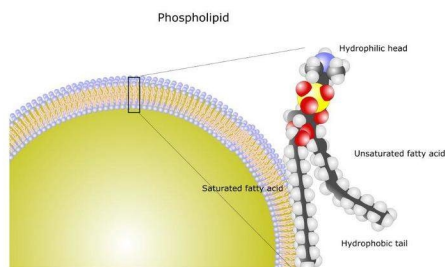

### Steroids

Steroids are lipids that have four rings made of carbon atoms—three rings have six sides and one has five sides—with a six-carbon ring tail. Examples: bile salts, cholesterol, the sexual hormones estrogen, progesterone and testosterone, corticosteroids and pro-vitamin D.

### Cholesterol

Cholesterol is an important molecule found only in eukaryotic organisms with a variety of functions. Cholesterol is also a component of biological membranes and its main function is to control the fluidity of membranes. Cholesterol does not like to be exposed to water environments, preferring to be shielded by other hydrophobic molecules such as lipids or hydrophobic parts of proteins.

Cholesterol also serves as the primary source for the production of steroid hormones, bile salts, and vitamin D.

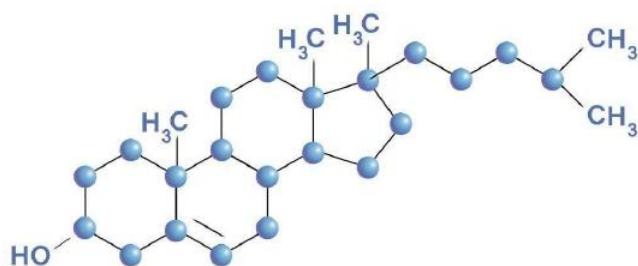

## Cholesterol

### 1.4

Nucleosides and nucleotides are involved in the preservation and transmission of the genetic information of all living creatures. In addition, they play roles in biological energy storage and transmission, signaling and regulation of various aspects of metabolism.

These molecules can be divided into two major families.

## Nitrogenous bases

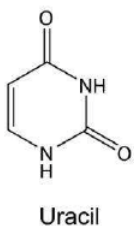
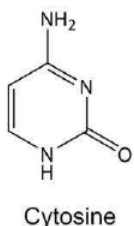
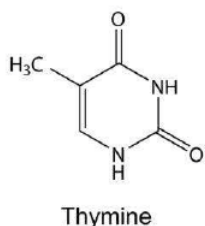
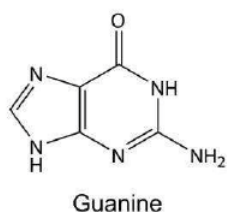
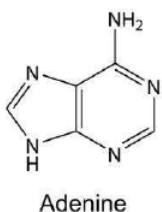

**Purines:** They are two-ring structures: adenine and guanine.

**Pyrimidines:** They are one-ring structures: thymine, cytosine, and uracil.

The unique structure and interaction of these molecules serve as the fundamental building block of RNA and DNA molecules and allow fundamental processes of DNA replication and protein synthesis to occur.

### Components of Nucleotides

- **Nitrogenous base:** The nitrogenous base of a nucleoside or nucleotide may be either a purine or a pyrimidine.
- **Carbohydrate:** The carbohydrate component of nucleosides and nucleotides is usually the sugar ribose for RNA molecules and deoxyribose for DNA molecule
- **Phosphate Group:** One or more phosphate groups (PO<sub>4</sub>-3) may be attached to the carbon 5 of the carbohydrate molecule.

### Adenosine triphosphate (ATP)

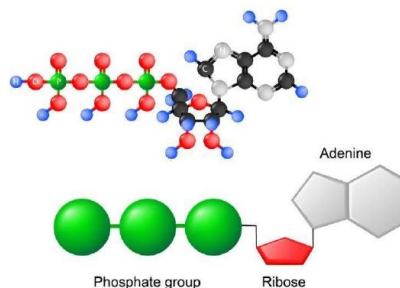

### 1.5



## DNA

**DNA stands for deoxyribonucleic acid.**

It is an extremely long molecule that forms a double-helix.

### DNA Structure

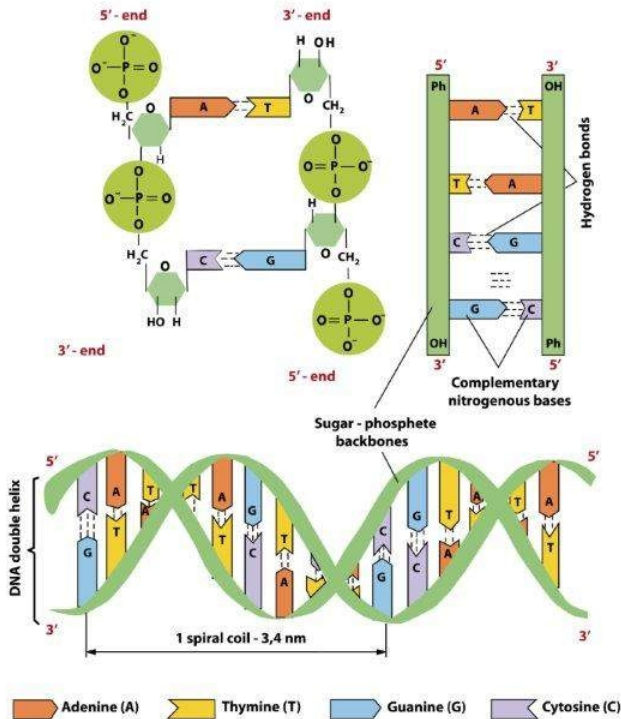

mature red blood cells); Gametes or sex cells (sperm and eggs) have half the normal complement of chromosomes.

## 1.6

## RNA

**RNA stands for ribonucleic acid.**

RNA molecules are single strands.

**RNA components:**

- Sugars - Ribose
- Phosphates - (PO<sub>4</sub><sup>-3</sup>)
- Base: cytosine (C), guanine (G), adenine (A) and uracil (U)

RNA molecules often form secondary (2°) structures and may interact with DNA, other RNA molecules, and proteins. These interactions help to define the particular function of each type of RNA.

**Types of RNA molecules and functions:**

**Messenger RNA (mRNA):**

Molecules which function as the transmitter of genetic information from the DNA genetic code to the resulting protein.

**DNA components:**

- Sugars - Deoxyribose
- Phosphates - (PO<sub>4</sub><sup>-3</sup>)
- Base - cytosine (C), guanine (G), adenine (A) and thymine (T).

The DNA consists of two strands attached to each other by hydrogen bond created by nucleotide pairing (A-T and C-G).

The **double-helix** structure of DNA is important for its function because these two bonded strands can temporarily separate to allow for DNA replication.

The sequences of nucleotides (A, C, T, G) in the DNA molecule will make up the **genes** and, subsequently, proteins are referred to as “expressed sequences” or “exons.” Sequences that do not code for a protein are called “intervening sequences” or “introns.”

**Human Genome**

The genome of humans is estimated to contain approximately 20,000–25,000 different genes arranged on multiple chromosomes.

**Twenty three pairs of chromosomes:**

**Twenty two pairs (autosomes).**

**One pair (sex chromosome) (xx) (female) or (xy) (male).**

Humans have 23 pairs of chromosome in every cell (except

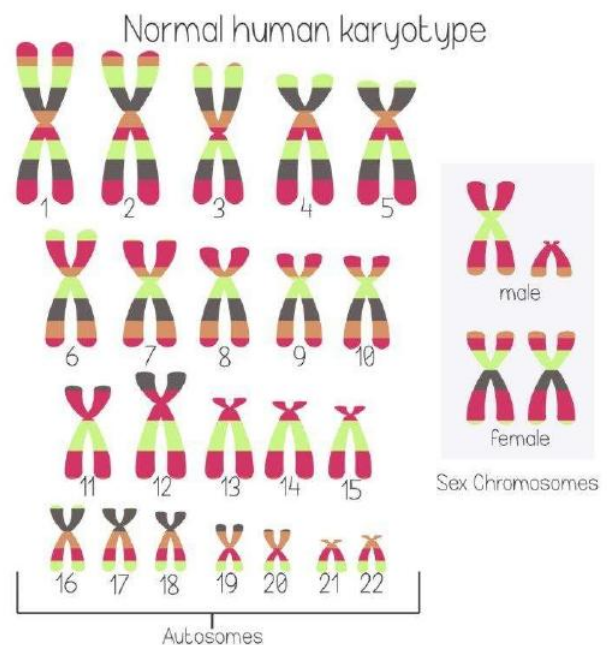

### Transfer RNA (tRNA)

Molecules that carry amino acids and match them with a specific mRNA sequence during protein synthesis.

### Ribosomal RNA (rRNA)

Molecules associated with proteins and are responsible for the synthesis of protein molecules.

### Regulatory RNA

Molecules involved in regulation of DNA expression, posttranscriptional mRNA processing, and the activity of the transcribed mRNA message.

The basic structure of DNA and RNA are similar, however with 3 main differences:

**Nitrogenous Bases:** Three of the nitrogenous bases are the same in the DNA and RNA: adenine, cytosine, and guanine. The fourth base for DNA is thymine while for RNA it is uracil. Thymine and uracil both bind to adenine.

**Number of Strands:** The DNA molecule is usually double-stranded and most cellular RNA molecules are single-stranded.

**Type of Sugar:** In the DNA molecule the sugar is **deoxyribose** and in the RNA molecule the sugar is **ribose**.

### Topic 1: Key Points

In this section, we explored the following main points:

- 1: Amino acids link together, in a reaction known as peptide bond, to form proteins.
- 2: One important function of protein is to act as enzymes to accelerate chemical reactions.
- 3: Carbohydrates are important energy source required for various metabolic activities and may bind to proteins and lipids that play important roles in cell interactions
- 4: Lipid molecules serve as storage of biological energy and provide the building blocks for biological membranes
- 5: DNA and RNA structures have 3 main differences .The nitrogenous bases (DNA has thymine and RNA has uracil). The DNA molecule is usually double stranded and most of the RNA molecules are single stranded. In the DNA molecule the sugar is deoxyribose and in the RNA molecule the sugar is ribose.

## RNA Structure

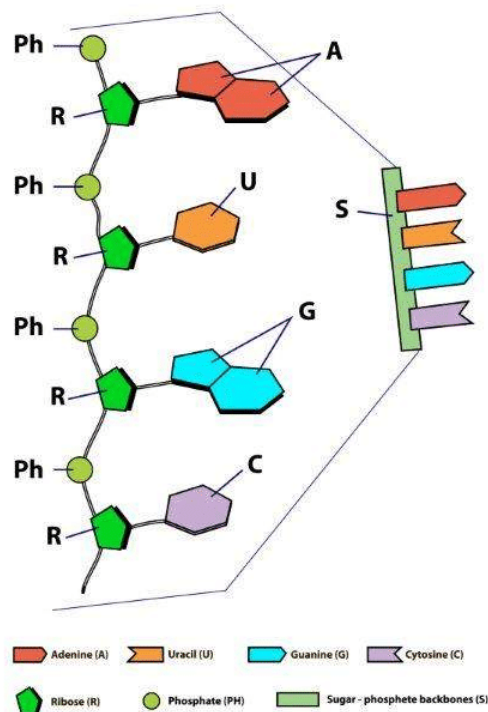

### Knowledge Check

1. What type of nucleic acid does thymine belong to?

**Answer**

DNA

2. Uracil?

**Answer**

RNA

3. Enzymes are...

specialized proteins that accelerate a chemical reaction by serving as a biological catalyst.

specialized proteins that stops a chemical reaction.

## Structure of DNA & RNA

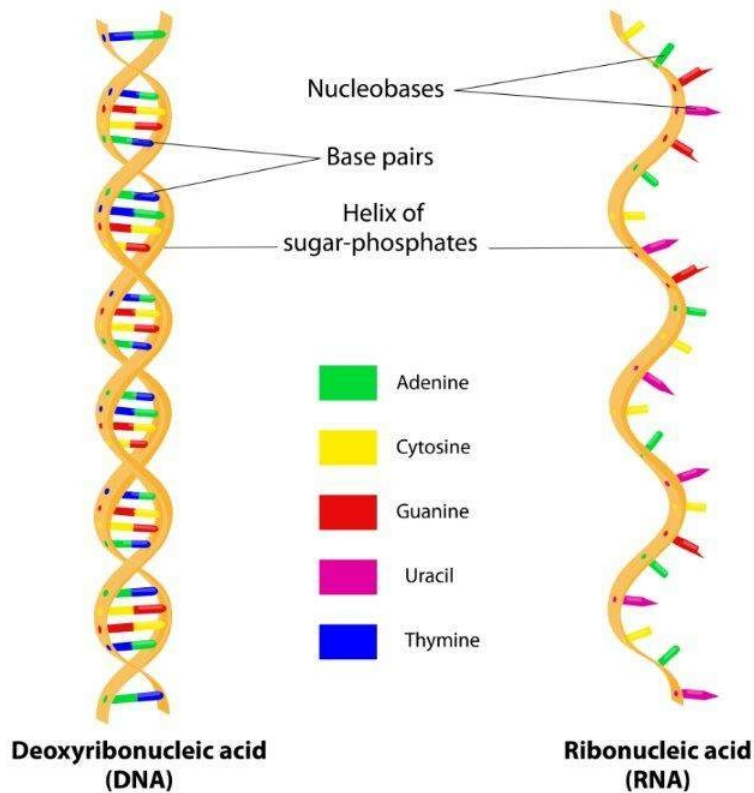

### Answer

specialized proteins that accelerate a chemical reaction by serving as a biological catalyst.

### 4. A nucleotide consists of...

*Check all that apply.*

- A sugar (either deoxyribose or ribose )
- Uracil as the nitrogen base
- A phosphate group
- One of the four nitrogen bases

### Answer

A sugar, A phosphate group, and One of the four nitrogen bases

### 5. Lipid molecules are mainly hydrophilic molecules. True or False?

### Answer

false

This page titled [2.1: Introduction to Biomolecules and Cell Components](#) is shared under a [CC BY-NC 4.0](#) license and was authored, remixed, and/or curated by [ToxMSDT Online component](#) via [source content](#) that was edited to the style and standards of the LibreTexts platform.

## 2.2: Cell Structure and Subcellular Compartments

### Learning Objectives

- 1: Describe the basic components of cell structure and organelles.
- 2: Understand the chromatin organization into nucleus.
- 3: Understand basic mechanisms of cell signaling to respond to changes in the environment.

### 2.1

#### Structure of a cell

Cells are the smallest unit of life. A typical eukaryotic cell and its components are illustrated in the next figure.

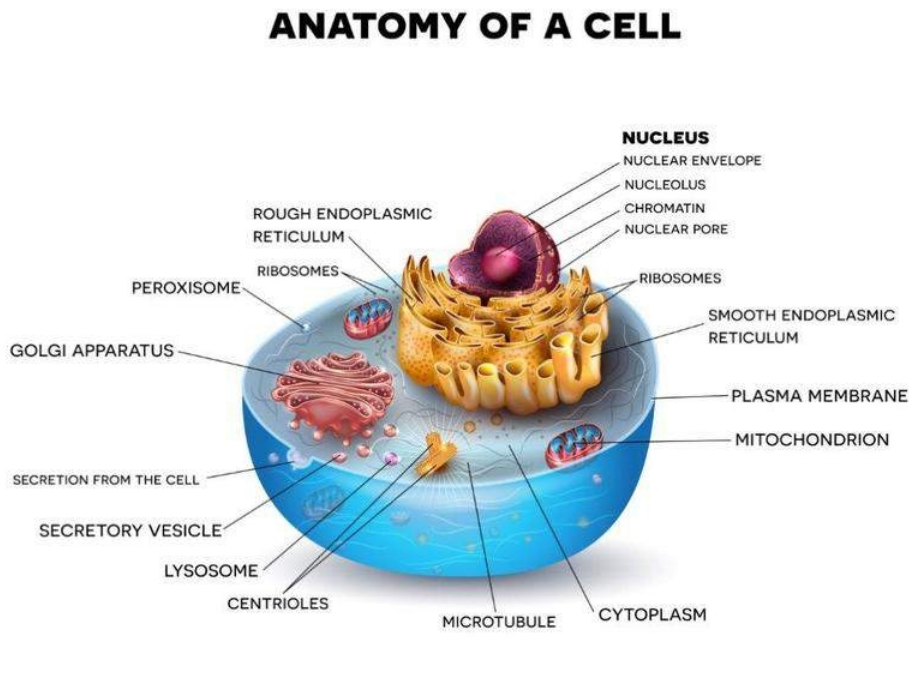

#### CELL MEMBRANE

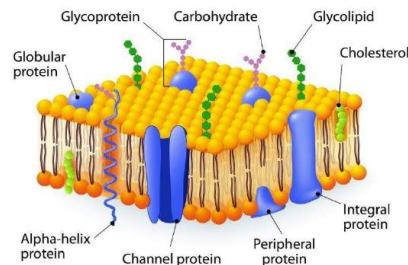

#### Membrane:

Plasma membrane, nuclear envelope, and membranes provide separation of different environments to permit a variety of biological functions. Membranes are dynamic and fluid structures that allow selective movement of ions, energy sources, vitamins and cofactors, and waste. Membrane components include lipid, carbohydrates and protein molecules. Membrane fluidity is very important for its functions and, as a consequence, is important in disease processes, as well as, treatments.

Figure 2.2.1: Structure of cell membrane

Membranes are composed of lipids arranged in a **lipid bilayer**, with the hydrophilic glycerol and phosphate “head” groups of the lipid molecules forming the two outside layers and the hydrophobic “tail” groups arranged inside. Proteins are the second major part of biological membranes and makeup approximately 20%–80% of both the structural and functional components of these membranes. Many of these proteins are embedded into the membrane and stick out on both sides; these are called **transmembrane proteins**.

## 2.2

### Subcellular compartments

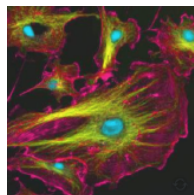

#### CYTOSKELETON

is a structure that helps cells maintain their shape and internal organization, and it also provides mechanical support that enables cells to carry out essential functions like division and movement. The cytoskeleton is made up of microtubules, actin filaments, and intermediate filaments.

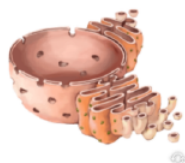

#### ENDOPLASMIC RETICULUM (ER)

It consists of a system of sac- and tube-like structures, which locally expand into cisterns. Its internal lumen is connected with the intermembrane space of the nuclear membrane. Part of the ER is studded on the outside with ribosomes (rough ER), which take part in protein synthesis. The other part of the ER is free of ribosomes (smooth ER). Enzymes of the smooth ER are involved in the synthesis of fatty acids. The smooth ER also plays a

role in detoxification by hydroxylation reactions.

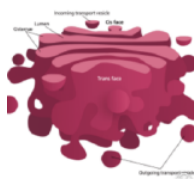

#### GOLGI APPARATUS

This organelle consists of stacks of flattened membrane sacs. Their main function is the further processing and sorting of proteins and their export to the final targets. In most cases, these are secreted as membrane proteins. In addition, the Golgi apparatus also produces polysaccharides.

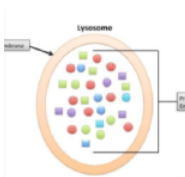

#### LYSOSOMES

Lysosomes are vesicles enclosed by a lipid bilayer. These organelles are filled with many enzymes for polysaccharide, lipid, protein and nucleic acid degradation. They act also on intracellular material to be removed and even contribute to the apoptosis of their own cell. Lysosomes of special cells (e.g., macrophages) destroy bacteria or viruses as a defense mechanism.

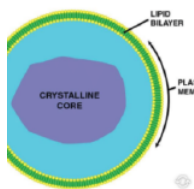

#### PEROXISOMES

Peroxisomes are surrounded by a single membrane. They are generated from components of the cytosol and do not bud from other membranes. The main task of these organelles is the performance of monooxygenase (hydroxylase) or oxidase reactions, which produce hydrogen peroxide (H<sub>2</sub>O<sub>2</sub>).



#### MITOCHONDRIA

In a typical eukaryotic cell, there are in the order of 2000 of these organelles, which are often of ellipsoidal shape. They have a smooth outer membrane and a highly folded inner membrane with numerous invaginations (cristae), which contain most of the membrane-bound enzymes of mitochondrial metabolism. Mitochondria are the site of respiration and ATP synthesis, but also of many other central reactions of metabolism, e.g., citrate cycle,

fatty acid oxidation, glutamine formation, and part of the pathway leading to steroid hormones. Mitochondria are the only organelles which are equipped with their own (circular) DNA, RNA and ribosomes and thus can perform their own protein synthesis.

#### NUCLEUS

All eukaryotic cells show the presence of a separate nucleus, which contains the major portion of the genetic material of the cell (DNA). The nuclear DNA is organized in a number of chromosomes. The nucleus is surrounded by a double membrane of lipid bilayers with integrated proteins, called the nuclear membrane (also known as the nuclear envelope). Nuclear pores span the nuclear membrane and enable the transport of proteins, rRNA etc.



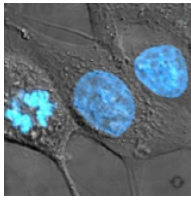

**Image credits**

2. DataBase Center for Life Science (DBCLS) licensed under [CC BY 4.0](#)
3. Kelvin Song licensed under [CC BY 3.0](#)
4. Lumoreno licensed under [CC BY-SA 3.0](#)
5. Agateller licensed under [CC BY-SA 3.0](#)

2.3

**Structure of Chromatin**

Chromosomal DNA is packaged inside microscopic nuclei by its association of histones H2A, H2B, H3, and H4. These are positively-charged proteins that strongly adhere to negatively-charged DNA and form complexes called nucleosomes. (11-nm “beads on a string” structure). Each nucleosome is composed of DNA wound 1.65 times around eight histone proteins. Nucleosomes fold up to form a 30-nanometer chromatin fiber, which forms loops averaging 300 nanometers in length. The 300 nm fibers are compressed and folded to produce a 250 nm-wide fiber, which is tightly coiled into the chromatid of a chromosome. The level of structure varies depending on the cell cycle stage and, as a result, the requirement for DNA transcription or replication.

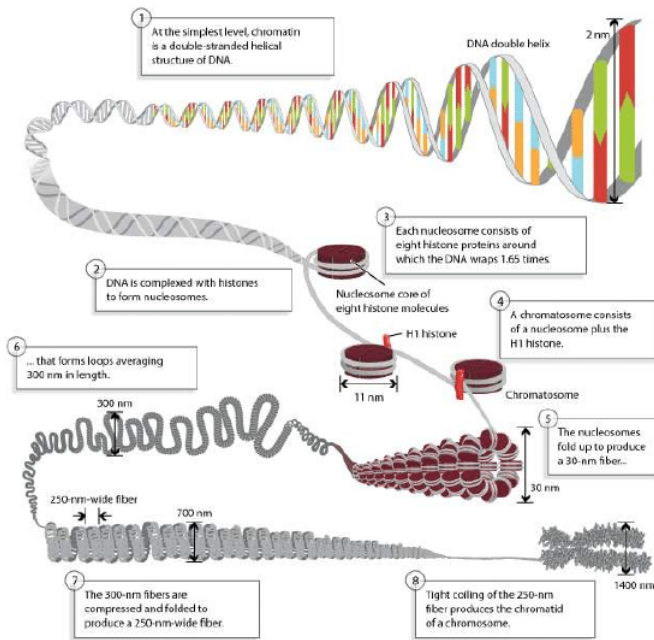
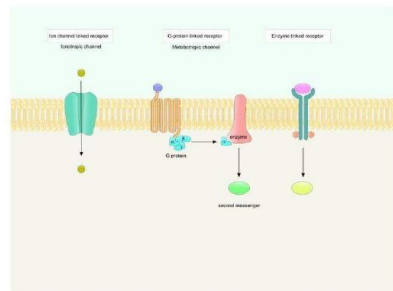

Figure 2.2.2: Chromosomes are composed of DNA tightly-wound around histones - © 2010 Nature Education

**Chromatin:** The most important structure inside the nucleus is **chromatin**, consisting, in humans, of the 46 chromosomes. Chromatin is the combination or complex of DNA and proteins that make up the contents of the nucleus of a cell. The most abundant protein in the nucleus are histones. Histones are rich in basic amino acids (positively charged), which interact with negative charges of the DNA.

2.4

**Cell Signaling**



Cell signaling consists in the ability of cells to respond to environment changes through signals received outside their borders. Cells may receive many signals simultaneously and also send out

messages to other cells.

Cells have proteins called receptors, that are generally transmembrane proteins, which bind to signaling molecules outside the cell and subsequently transmit the signal through a sequence of molecular switches to internal signaling pathways and initiate a physiological response. Different receptors are specific for different molecules. In fact, there are hundreds of receptor types found in cells, and varying cell types have different populations of receptors.

Figure 2.2.3: Main types of transmembrane receptors

**Examples of receptors membrane:**

- G-protein-coupled receptors
- Ion channel receptors
- Enzyme-linked receptors

Receptor may be located in the cellular membrane (important to receive extracellular signals) but also may be present inside the cell or inside the nucleus.

## Topic 2: Key Points

In this section, we explored the following main points:

- 1: The characteristics of the cell membrane, such as lipid bilayer and transmembrane proteins are very important for the cell function.
- 2: The chromatin is the combination of complex DNA and proteins that make up the contents of the nucleus of a cell.
- 3: Cells have proteins called receptors that are important to receive extracellular signals and initiate signaling pathways in the cell.

### Knowledge Check

#### 1. Histones are proteins present in the nucleus of the cells with the function of:

- interacting with the DNA to form nucleosomes.
- regulating the fluidity of cell membranes.

#### Answer

interacting with the DNA to form nucleosomes.

#### 2. Membranes are composed of lipids arranged in a ...

*Check all that apply.*

- lipid monolayer, with...
- lipid bilayer, with...
- ...the hydrophilic glycerol and phosphate “head” groups of the lipid molecules forming the two outside layers and the hydrophobic “tail” groups arranged inside.
- ...the hydrophilic and hydrophobic “tail” groups arranged inside.

#### Answer

lipid bilayer, with...the hydrophilic glycerol and phosphate “head” groups of the lipid molecules forming the two outside layers and the hydrophobic “tail” groups arranged inside.

This page titled [2.2: Cell Structure and Subcellular Compartments](#) is shared under a [CC BY-NC 4.0](#) license and was authored, remixed, and/or curated by [ToxMSDT Online component](#) via [source content](#) that was edited to the style and standards of the LibreTexts platform.

## 2.3: DNA and RNA Metabolism

### Learning Objectives

After completing this lesson, you will be able to:

- Understand the mechanism of DNA replication.
- Understand the process of gene expression.
- List the main types of DNA mutation and mechanism of DNA repair.

### DNA Replication

The process of DNA replication consists of uncoiling double-stranded DNA, copying each DNA strand and then separating the two, new, double-stranded copies. The process starts at an **origin of replication (ori)**, a nucleic acids sequence where the replication can start. There are around 100,000 origins of replication in each human cell. This means that the DNA replication may start simultaneously in different positions at the same time. The **replication fork** is the point where two DNA strands, one termed the **leading strand** and the other the **lagging strand**, are separated and DNA copying occurs. The coiled-coil, double-helical DNA structure is initially unwound by the enzyme **DNA helicase** by breaking the hydrogen bonds between complementary nucleic acids. **Single-stranded binding proteins** attach to the new DNA strands to keep them separated.

An enzyme termed **primase** then produces a short strand of RNA to serve as a primer for the remainder of the process. The enzyme **DNA polymerase** replicates each DNA strand in the 5' to 3' direction by adding the correct, matching nucleotide triphosphate to the 3'-hydroxyl end of the primer strand. As each new nucleic acid is added, a new phosphodiester bond is formed, utilizing the energy contained in the remaining diphosphate group.

## DNA replication

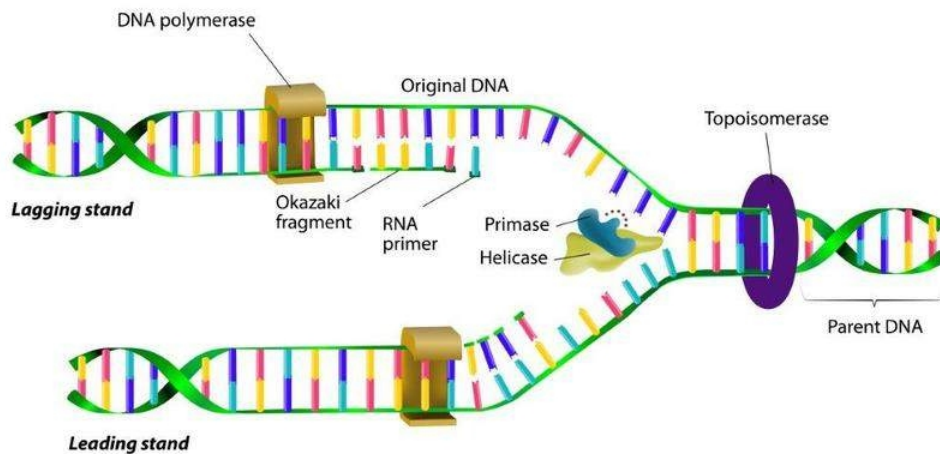

### RNA Transcription

RNA Transcription is the process whereby a particular segment of DNA is transcribed into an equivalent RNA sequence.

- mRNA: For genes that codes for a protein.
- tRNA: For a transfer RNA.
- rRNA: For assembly of a ribosome.
- miRNA (micro RNA): Which binds to mRNA and inhibits its translation.
- siRNA (small-interfering RNA): Which binds to mRNA and aids in its degradation.
- snRNA (small nuclear RNA): Which participates in RNA processing as part of the spliceosomes.
- snoRNA (small nucleolar RNA): Which participate in nucleolar RNA processing.



The transcription starts with binding of the enzyme **RNA polymerase** to a **promoter** sequence on the DNA, a regulatory region that dictates where the transcription should start.

The DNA is transcribed from 3' to 5' and occurs only on one of the DNA strands, the **template strand**.

As in DNA replication, energy for the formation of the phosphodiester bond is derived from hydrolysis of the two terminal phosphate bonds of the nucleoside triphosphate.

Multiple RNA polymerases can transcribe on a single DNA gene sequence, allowing rapid production of the RNA product.

**Enhancer:** This is a short region of DNA that can be bound by transcription factors to increase or facilitate the transcription of a particular gene. They can be located up away from the gene, upstream, or downstream from the start site.

**Transcription Factors (TFs):** These include a wide number of proteins, excluding RNA polymerase, that promotes (as an activator), or blocks (as a repressor) the recruitment of RNA polymerase to DNA. TFs bind to promoter regions of DNA.

**Promoter Region:** These are specific DNA sequences, usually located upstream and near the transcription start sites of genes and serves as a binding site for proteins called transcription factors that recruit RNA polymerase. Example: TATA box, CpG island.

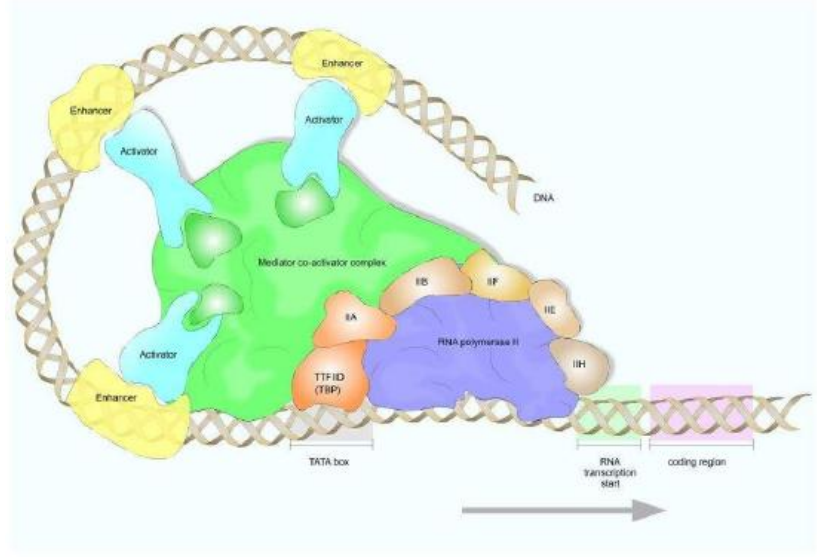

Figure 2.3.1: Machinery of RNA transcription

## RNA Processing

The newly synthesized RNA transcripts are processed prior to their use in the cell as mature RNA.

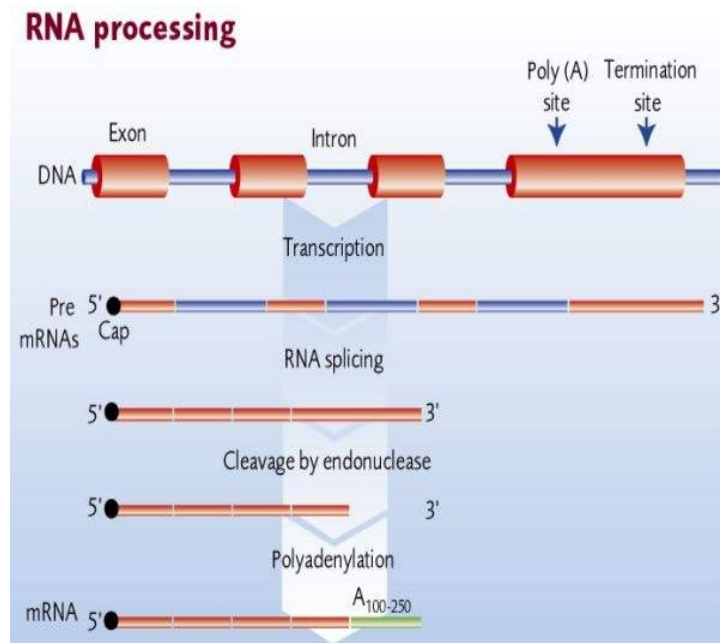

Figure 2.3.2: RNA processing

A 7-methyl guanosine nucleic acid is added to the 5'-end (known as a **5' cap**) of the pre-mRNA as it emerges from RNA polymerase II (Pol II). The cap protects the RNA from being degraded by enzymes and serves as an assembly point for the proteins to begin translation to protein.

Removal of **introns** present in the pre-mRNA and splicing of the remaining **exons**, in a process called **RNA splicing**. The continuous series of DNA bases coding for a protein are interrupted by base sequences that are not translated. The translated sequences are referred to as exons (expressed sequences) and the nontranslated sequences as introns (intervening sequences). This completes the mRNA molecule, which is now ready for export to the cytosol. (The remainder of the transcript is degraded, and the RNA polymerase leaves the DNA.)

### 3.4 Protein Translation

Protein synthesis requires the interaction of **mRNA**, **tRNA**, several accessory proteins, called **initiation factor (IF)** and **elongation (EF)** factor, and **ribosomes**.

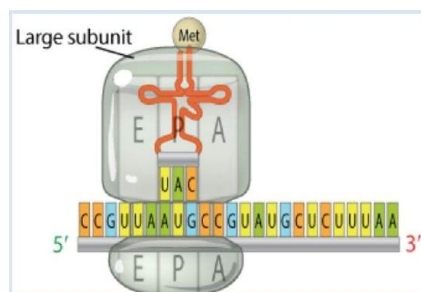

The large ribosomal subunit binds to the small ribosomal subunit to complete the initiation complex. The tRNA molecule binds to one amino acid at the top of the structure. In the base of the tRNA there is the three base sequence known as the **anticodon**.

This anticodon binds, through base pairing, to a three base codon on mRNA. It is this interaction between the mRNA and the amino acid-tRNA that provides the high degree of fidelity observed in the transfer of genetic information from DNA to proteins.

Figure 2.3.3: Transfer RNA (tRNA) - © 2013 Nature Education

#### The Triplet Code (Genetic Code)

A sequence of three bases in DNA identifies each of the 20 amino acids that are to be incorporated into the newly synthesized protein. This information is incorporated into mRNA which is synthesized using DNA as the template. Considering that three bases are required at a minimum, and we have 4 nucleotides (  $4^3 = 64$  code words are possible). This is more than the 20 amino acids. In fact, many triplets are used to define one same amino acid. In addition, some “extra” triplet sequences are used as stop codons to terminate protein synthesis. AUG is used as the start codon for the N-terminal amino acid in eukaryotes.

Using the same binding rules as DNA double strands (e.g., a tRNA that binds the starting mRNA codon AUG has an anticodon sequence of UAC), insuring the specific order of AAs required for proper production of the protein.

		Second nucleotide					
		U	C	A	G		
U	UUU	Phe	UCU	UAU	Tyr	UGU	Cys
	UUC		UCC	UAC		UGC	
	UUA	Leu	UCA	UAA	STOP	UGA	STOP
C	CUU		CCU	CAU	His	CGU	Arg
	CUC	Leu	CCC	CAC		CGC	
	CUA		CCA	CAA	Gln	CGA	
A	AUU	Ile	ACU	AAU	Asn	AGU	Ser
	AUC		ACC	AAC		AGC	
	AUA		ACA	AAA	Lys	AGA	Arg
G	AUG	Met	ACG	AAG		AGG	
	GUU		GCU	GAU	Asp	GGU	Gly
	GUC	Val	GCC	GAC		GGC	
G	GUA		GCA	GAA		GGA	
	GUG		GCG	GAG		GGG	

Figure 2.3.4: Genetic code - © 2014 Nature Education

#### RNA plays three distinct and important roles:

- mRNA: The intermediary between gene and protein – provides the message.
- tRNA: The key or adaptor – reads the genetic code, brings amino acids to the growing polypeptide chain
- rRNA: In ribosome, provides a scaffold for protein synthesis, catalyzes peptide bond formation

The IF and EF accessory proteins serve a number of roles, including enabling binding of the mRNA molecule to the ribosome, movement of the mRNA along the ribosome to the start point of the synthesis, docking of the tRNA–amino acid, and movement of the mRNA and growing peptide chain, as well as accuracy assurance.

The protein biosynthesis, can be divided into three phases: initiation, elongation, and termination.

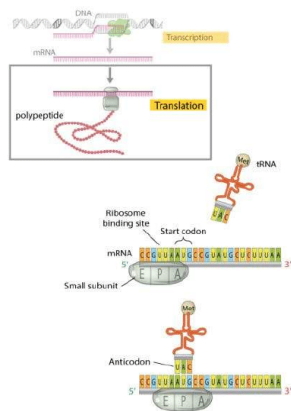

### Initiation

Initiation of protein synthesis begins when the protein initiator factor IF-3 binds to the small subunit of the ribosome and causes its dissociation. The small ribosomal subunit then binds to the 5' side of mRNA which carries information in a triplet code from DNA. The small subunit is then translocated where it meets the large ribosomal subunit, other protein initiator factors, and initiator tRNA. The tRNA is bound to methionine at a site in the ribosome known as the P site.

### Elongation

In the elongation phase of protein synthesis, a specific aminoacyl-tRNA, directed by hydrogen bonding interactions between the anticodon region of the aminoacyl-tRNA and the codon region of mRNA, adds to a site distinct from the P site, the A site. The A and P sites are in close proximity, allowing the peptide bond formation between the amino acids. The newly synthesized tRNA bound dipeptide then moves from the A site to the P site. After a translocation of the

ribosome in the 5' - 3' direction along the mRNA occurs to expose a new codon. Then, another amino acid-tRNA identity and binds to the mRNA at the A site and the peptidyl transferase reaction is again initiated. As the polypeptide chain grows through subsequent cycles of amino acid residue incorporation, it emerges from the ribosome and undergoes folding into its native secondary and tertiary conformations.

### Termination

In termination step, the peptide bond synthesis ceases when a stop codon on the mRNA is reached. This termination site will not bind aminoacyl-tRNA and peptide synthesis stops. Release factors allow the newly synthesized protein to dissociate from the ribosome.

## 3.5 Gene Expression

Gene expression is a two-step process in which DNA is converted into a protein.

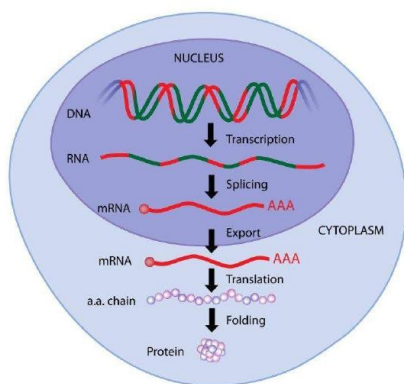

**Step 1:** The first step is DNA transcription to RNA. In this step, the information from the archival copy of DNA is imprinted into mRNA. The structure of RNA is a little different, it contains ribose instead of deoxyribose, and the four bases that bind to it are cytosine (C), guanine (G), adenine (A), and uracil (U). During transcription, DNA unfolds, and mRNA is created by pairing mRNA bases with the bases of DNA. In this process C in DNA translates to G, G to C, **A to U**, and T to A. After mRNA is transcribed it is transported to the ribosome.

**Step 2:** The second step, protein translation occurs at the ribosome. During translation, the sequence of codons (triplet of bases) of mRNA is, with the help of tRNA, translated into a sequence of amino acids

Figure 2.3.5: Gene expression seems to be a straightforward process, the mechanism that control the gene expression that causes most phenotypic differences in organisms.

## 3.6 Mutation



Mutations are changes in the genetic sequence (DNA or RNA sequence), and they are a main cause of diversity among organisms. Although some of mutations are beneficial, offering resistance to disease or improved structure and/or function, some other specific mutations can lead to disease and/or death of the cell or organism.

Mutations can occur due to assaults from the environment or spontaneous mutation may occur during the DNA replication. Mutations are estimated to occur at an approximate rate of 1000–1,000,000 per cell per day in the human genome, and every new cell is

believed to contain approximately 120 new mutations.

### TYPES OF MUTATION

Point mutations when only a single base pair is changed into another base pair. They can be classified as the following:

- **Transition:** When a purine nucleotide is changed to a different purine ( $A \leftrightarrow G$ ) or a pyrimidine nucleotide is changed to a different pyrimidine nucleotide [ $C \leftrightarrow T(U)$ ].
- **Transversion:** When the orientation of a single purine and pyrimidine nucleotide is reversed [ $A/G \leftrightarrow C/T(U)$ ].
- **Silent:** When the same AA is coded.
- **Missense:** When a different AA is coded.
- **Neutral:** When an AA change occurs but does not affect the protein's structure or function.
- **Nonsense:** When a stop codon results, terminating translation and shortening the resulting protein.

**Insertion** and **deletion** mutations, which are together known as **indels**. Indels can have a wide variety of lengths. At the short end of the spectrum, indels of one or two base pairs within coding sequences have the greatest effect, because they will inevitably cause a frameshift, i.e. change the entire reading of the mRNA sequence. At the intermediate level, indels can affect parts of a gene or whole groups of genes. At the largest level, whole chromosomes or even whole copies of the genome can be affected by insertions or deletions. At this high level, it is also possible to invert or translocate entire sections of a chromosome, and chromosomes can even fuse or break apart.

If a large number of genes are lost as a result of one of these processes, then the consequences are usually very harmful.

### 3.7 DNA Repair

The human body has mechanisms to detect and repair the various types of damage that can occur to DNA, no matter whether this damage is caused by the environment or by errors in replication.

Because DNA is a molecule that plays an active and critical role in cell division, during the cell cycle, checkpoint mechanisms ensure that the DNA is intact before permitting DNA replication and cell division to occur. Failures in these checkpoints can lead to an accumulation of damage, which in turn leads to mutations.

UV radiation causes DNA lesions that may distort DNA's structure, introducing bends or kinks and thereby impeding transcription and replication. These lesions may be repaired through a process known as **nucleotide excision repair (NER)**, a mechanism where an enzyme catalyzes the removal of damaged nucleotides, and replacement of the correct sequence, guided by the intact complementary DNA strand. Defects in this mechanism are related to human diseases like skin cancer.

Another repair mechanism that handles the spontaneous DNA damage caused by oxidation or hydroxylation generated by metabolism is the **base excision repair (BER)**. In this mechanism, enzymes known as DNA glycosylases remove damaged bases by literally cutting them out of the DNA strand through cleavage of the covalent bonds between the bases and the sugar-phosphate backbone. The resulting gap is then filled by a specialized repair polymerase and sealed by ligase.

DNA damage also may occur in form of double-strand breaks, which are caused by ionizing radiation, including gamma rays and X-rays. Double-strand breaks may be repaired through one of two mechanisms: **nonhomologous end joining (NHEJ)**, where an enzyme called DNA ligase IV uses overhanging pieces of DNA adjacent to the break to join and fill in the ends; or **homologous recombination repair (HRR)** where the homologous chromosome itself is used as a template for repair.

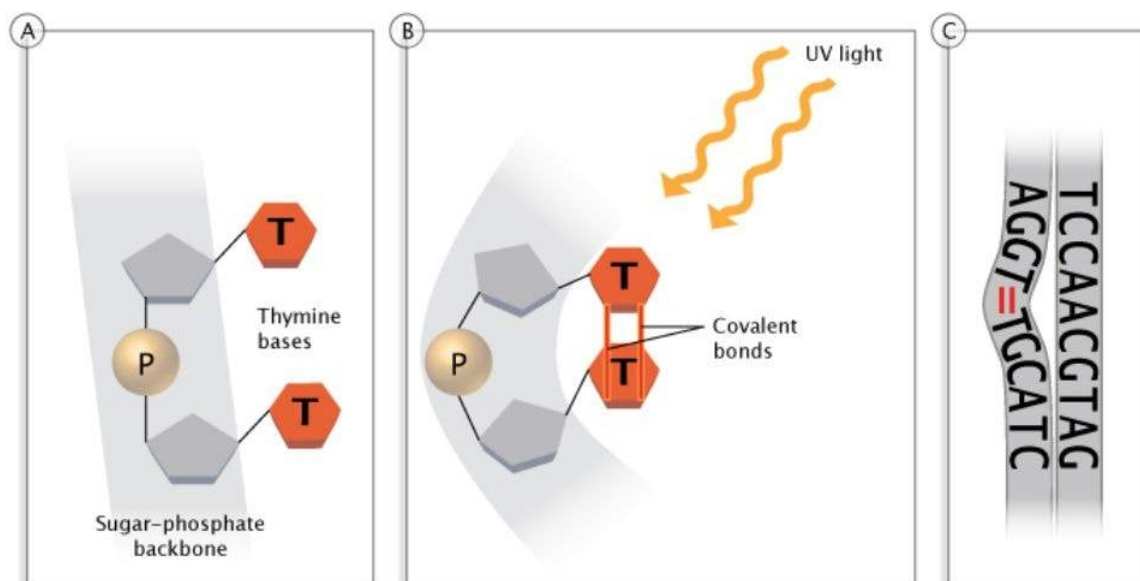

Figure 2.3.6: UV Radiation can distort DNA, impeding transcription and replication. A region of DNA is shown before (A) and after (B) its structure is distorted by UV radiation. The distortion in panel B is due to a convex bend in one strand (C). - Source: © Nature Education

### Topic 3: Key Points

In this section, we explored the following main points:

1. The process of DNA replication is controlled by several proteins that act together to assure the correct base pairing for creation of the new DNA strand.
2. Transcription is the first step of gene expression, in which a particular segment of DNA is copied into RNA (mRNA) by the enzyme RNA polymerase.
3. In translation, messenger RNA (mRNA)—produced by transcription from DNA—is decoded by a ribosome and tRNA to produce a specific amino acid chain, or protein.
4. Mutations are changes in the genetic sequence (DNA or RNA sequence), that can be beneficial or may result in damage, if not repaired.

#### Knowledge Check

1. RNA splicing is the process which involves the removal of introns present in the pre-mRNA and splicing of the remaining exons. True or False?

- True
- False

#### Answer

true

2. Which of the following does not belong to the process of DNA replication?

- Primase
- DNA Polymerase
- RNA Polymerase

#### Answer

RNA Polymerase

3. During protein translation, the sequence of codons (triplets of bases) of mRNA is important to:

Maintain the structure of the mRNA

Translated the correct a sequence of amino acids.

DNA replication

**Answer**

Translated the correct a sequence of amino acids.

---

This page titled [2.3: DNA and RNA Metabolism](#) is shared under a [CC BY-NC 4.0](#) license and was authored, remixed, and/or curated by [ToxMSDT Online component](#) via [source content](#) that was edited to the style and standards of the LibreTexts platform.

## 2.4: Epigenetic Mechanisms

### Learning Objectives

- 1: Identify the main epigenetic mechanisms related to control of gene expression.

### 4.1

#### Introduction

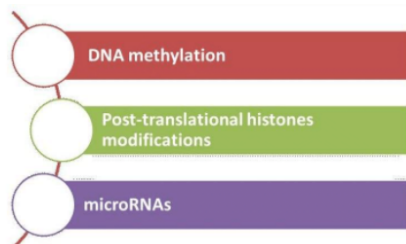

Epigenetics is defined as potentially heritable and reversible changes in gene expression mediated by methylation of DNA, modifications of histone proteins or by non-coding RNAs that are not due to any alteration in the DNA sequence. These processes singularly or jointly affect transcript stability, DNA folding, nucleosome positioning, chromatin compaction, and ultimately nuclear organization. They determine whether a gene is silenced or activated and when and where this occurs.

Epigenetic change is a regular and natural occurrence, essential for normal cell development, but can also be influenced by several factors including age, the

environment/lifestyle, and disease state.

### 4.2

#### DNA Methylation

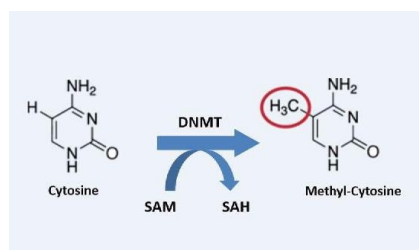

DNA methylation is a covalent modification of DNA, in which a methyl group is transferred from S-adenosylmethionine (SAM), that is converted to S-adenosylhomocysteine (SAH), to the 5 position of cytosine by a family of enzymes known as DNA methyltransferases (DNMT).

Figure 2.4.1: Disaccharide structure

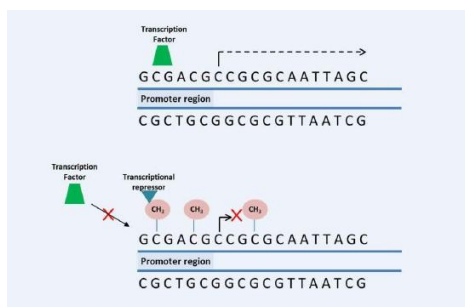

DNA methylation occurs predominantly in cytosines located in proximity of guanines, known as CpG dinucleotides (CpGs) or CpG island. These CpG island are found in promoter region of genes. The methyl group inhibits the binding of transcription factors to their recognition site, resulting in inhibition of gene transcription. Furthermore, the methyl group may attract other proteins know as transcriptional repressors that contributes for inhibition of gene transcription.

Figure 2.4.2: DNA methylation in the promoter region – Credit Aline de Conti

### 4.3



## Histones Post-Translational Modifications

The nucleosome is composed of five histone proteins (H1, H2A, B, H3, and H4). The N-terminus of these histone proteins are subject to covalent modifications such as methylation, phosphorylation, acetylation, ubiquitination or sumoylation by a group of histone-modifying enzymes. Alterations in these proteins contribute to the accessibility and compactness of the chromatin, and result in activation or suppression of particular genes.

### EXAMPLES OF TYPES AND ROLES OF HISTONE MODIFICATIONS

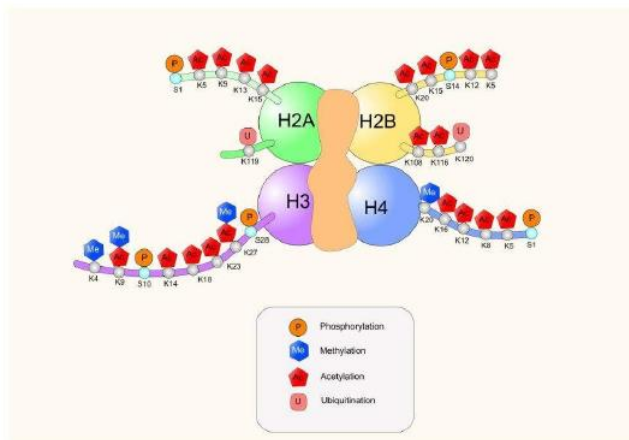

Figure 2.4.3: Histone sites of post-translational modifications.

Activation of gene Transcription:

Acetylation in the lysine 9(K9) of histone 3(H3) - H3K9ac

Acetylation in the lysine 27(K27) of histone 3(H3) - H3K27ac

Trimethylation in the lysine 4(K4) of histone 3(H3) - H3K4me3

Repression of gene transcription:

Trimethylation in the lysine 4(K3) of histone 3(H3) - H3K9me3

Trimethylation in the lysine 27(K27) of histone 3(H3) - H3K27me3

Trimethylation in the lysine 20(K20) of histone 3(H3) - H3K20me3

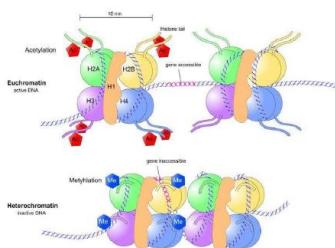

DNA methylation and histone post-translational modifications play important role in the establishment of chromatin structure and in consequence in the gene expression modulation. These epigenetic mechanisms can be independent or can happen together to control the gene expression. They also may influence each other, for example the histone methylation can help to direct DNA methylation patterns, and DNA methylation might serve as a template for some histone modifications after DNA replication.

Figure 2.4.4: Histone acetylation and methylation in gene regulation.

## 4.4

### microRNAs

miRNAs have an important role in gene regulation and they can influence biological functions including cell differentiation and proliferation during normal development and pathological responses. They are small non-coding RNA molecules (containing about



22 nucleotides), derived from regions of RNA transcripts that fold back on themselves to form short hairpins. They regulate gene expression at the post-transcriptional level. A number of miRNAs may bind to specific regions of the messenger RNA (mRNA) and block its translation to proteins. Alteration of the expression of miRNAs is believed to contribute to the progression of tumorigenesis and other diseases.

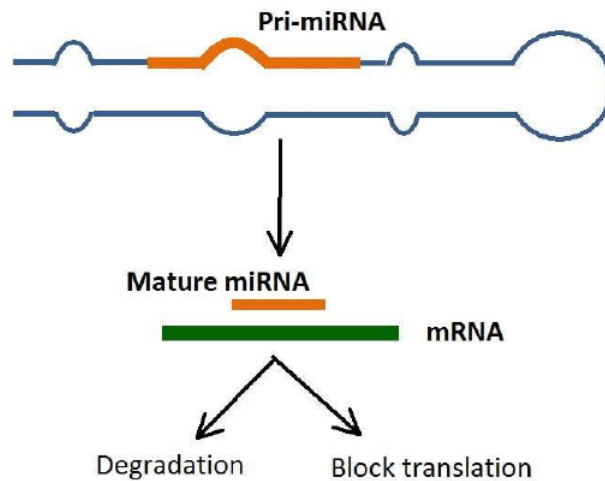

miRNA genes are usually transcribed by RNA polymerase II. miRNAs are initially transcribed as miRNA precursor termed a primary miRNA (pri-miRNA)

After processing the mature miRNA binds to mRNA target through base pairing

Gene silencing may occur either via mRNA degradation or preventing mRNA from being translated

Figure 2.4.5: Schematic representation of gene silencing by microRNA. Credit: Aline de Conti

#### Topic 4: Key Points

In this section, we explored the following main points:

- 1: Epigenetic mechanisms may influence gene expression without alteration in the DNA sequence.
- 2: Main epigenetic mechanisms are DNA methylation, histones post-translational modification and alteration in the expression of microRNAs.
- 3: Epigenetic change is a regular and natural occurrence but can also be influenced by several factors including age, the environment/lifestyle, and disease state.
- 4: Different from genetic alterations, epigenetic alterations are considered reversible.

 Knowledge Check

1. Epigenetic mechanisms are considered:

- Reversible
- Irreversible

**Answer**

Reversible

2. DNA methylation and histone post-translational modifications play important role in the establishment of chromatin structure and in consequence in the gene expression modulation. *True or False?*

- False
- True

**Answer**

True

3. DNA methylation may inhibit the binding of transcription factors to their recognition site, at promoter regions resulting in:

- Inhibition of gene transcription
- Activation of gene transcription

**Answer**

Inhibition of gene transcription

This page titled [2.4: Epigenetic Mechanisms](#) is shared under a [CC BY-NC 4.0](#) license and was authored, remixed, and/or curated by [ToxMSDT Online component](#) via [source content](#) that was edited to the style and standards of the LibreTexts platform.

## Section 2 Final Evaluation

---

**1. The carbohydrate component of a nucleoside and nucleotide is usually:**

- The sugar ribose for RNA molecule and deoxyribose for DNA molecule
- Carboxylic group for DNA molecule and amino group for RNA molecule
- The deoxyribose for RNA molecule and sugar ribose for DNA molecule
- The deoxyribose for RNA molecule and deoxyribose for DNA molecule

**Answer**

The sugar ribose for RNA molecule and deoxyribose for DNA molecule

**2. During protein translation, the sequence of codons (triplets of bases) of mRNA is important for:**

- Maintaining the structure of the mRNA
- Translating the correct sequence of an amino acid
- DNA replication
- DNA synthesis

**Answer**

Translating the correct sequence of an amino acid

**3. In DNA replication, the lagging strand short chains of nucleic acids, called Okazaki fragments, are generated and the enzyme DNA \_\_\_\_\_ joins the Okazaki fragments together with lagging strand for replication to proceed.**

- topoisomerase
- polymerase
- helicase
- ligase

**Answer**

ligase

**4. Point mutation when the orientation of a single base pair purine and pyrimidine nucleotide is reversed is termed:**

- Transition
- Missense
- Transversion
- Nonsense

**Answer**

Transversion

**5. The main function of \_\_\_\_\_ is to control the fluidity of biological membranes.**

- Glycerol
- Cholesterol
- Glucose
- Phospholipid

**Answer**

Cholesterol

**6. The smooth endoplasmic reticulum (ER) is involved in the synthesis of fatty acids and**

- Detoxification by hydroxylation reactions
- Provides mechanical support for cells
- Monooxygenase reaction to produce hydrogen peroxide ( $H_2O_2$ )
- Production of energy

**Answer**

Detoxification by hydroxylation reactions

**7. The only organelles which are equipped with their own (circular) DNA, RNA and ribosomes and can perform their own protein synthesis are:**

- Nucleus
- Golgi apparatus
- Peroxisomes
- Mitochondria

**Answer**

Mitochondria

**8. Phospholipids are the major component of cell membranes forming lipid bilayers because of their amphiphilic property whose structure consist of:**

- Two hydrophilic fatty acid “tails” and a hydrophobic head consisting of a phosphate group ( $PO_4^{3-}$ ) attached to the third glycerol carbon.
- Two hydrophobic fatty acid “tails” and a hydrophobic head consisting of a phosphate group ( $PO_4^{3-}$ ) attached to the third glycerol carbon.
- Two hydrophobic fatty acid “tails” and a hydrophilic head consisting of a phosphate group ( $PO_4^{3-}$ ) attached to the third glycerol carbon.
- Four hydrophilic fatty acid “tails” and a hydrophobic head consisting of a phosphate group ( $PO_4^{3-}$ ) attached to the third glycerol carbon.

**Answer**

Two hydrophobic fatty acid “tails” and a hydrophilic head consisting of a phosphate group ( $PO_4^{3-}$ ) attached to the third glycerol carbon.

**9. The most important structural component of a nucleus consisting of positively charged protein and negatively charged DNA is called:**

- Lysosome
- Chromatin
- Cytoskeleton
- Nucleolus

**Answer**

chromatin

**10. The difference between amino acids and fatty acids in terms of structure is that amino acids carry a carboxyl and an amino group while fatty acids carry a carboxyl and a methyl group.**

True

False

**Answer**

true

**11. An example of a nucleotide with a two ring structures is:**

Cytosine (C)

Adenine (A)

Uracil (U)

Thymine (T)

**Answer**

Adenine (A) [and also Guanine(G)]

**12. DNA methylation occurs predominantly in \_\_\_\_\_ to inhibit the binding of transcription factors to their recognition site which results in the inhibition of gene transcription.**

Guanine

Cytosine

Adenine

Thymine

**Answer**

Cytosine (C)

---

This page titled [Section 2 Final Evaluation](#) is shared under a [CC BY-NC 4.0](#) license and was authored, remixed, and/or curated by [ToxMSDT Online component](#) via [source content](#) that was edited to the style and standards of the LibreTexts platform.

## CHAPTER OVERVIEW

### 3: Principles of Genetic Toxicology

The genetic toxicology methodology or assay technique helps to test or evaluate the level of damages of the genetic information caused by toxicants or agents within the cells. In this e-module you will learn about different genetic toxicology assays, different genetic damages, and cytotoxicity and epigenetics assays.

[3.1: Introduction to Genetic-toxicology Assay](#)

[3.2: Different Genetic Damages or Mutations](#)

[3.3: Different Genetic-Toxicology Assays](#)

[3.4: Different Cytotoxicity Assays](#)

[3.5: Epigenetics Assay](#)

[Section 3 Final Evaluation](#)

---

This page titled [3: Principles of Genetic Toxicology](#) is shared under a [CC BY-NC 4.0](#) license and was authored, remixed, and/or curated by [ToxMSDT Online component](#) via [source content](#) that was edited to the style and standards of the LibreTexts platform.

## 3.1: Introduction to Genetic-toxicology Assay

### Learning Objectives

- Know about the definition of genetic toxicology assay.

### 1.1. What is Genetic-Toxicology Assay?

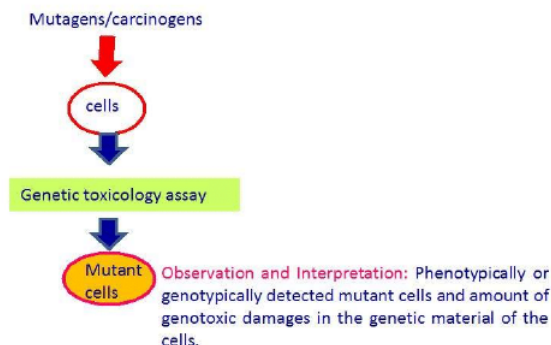

Figure 3.1.1: Diagrammatic steps in genetic toxicology assay.

The genetic-toxicology methodology or assay technique helps to test or evaluate the level of damage to the genetic information caused by toxicants or agents within the cells (Figure 1). Damages resulted as induced **mutations**, which may lead to different diseases including cancer. The causative toxic agents are known as **mutagens**. Mutagens caused for cancer disease, is known as **carcinogens**.

#### Topic 1: Key Points

In this section, we explored the following main points:

- 1: Definition of genetic toxicology methodology
- 2: Causative toxic agents as mutagens.
- 3: Genotoxic damages result in the phenotypically or genotypically mutant cells.

### Knowledge Check

Genetic-toxicology methodology or assay technique helps to test...

- the level of damages caused by toxicants within the cells.
- the level of reactive oxygen species (ROS) within the cells.
- the stages of cancer disease.

#### Answer

the level of damages caused by toxicants within the cells.

This page titled [3.1: Introduction to Genetic-toxicology Assay](#) is shared under a [CC BY-NC 4.0](#) license and was authored, remixed, and/or curated by [ToxMSDT Online component](#) via [source content](#) that was edited to the style and standards of the LibreTexts platform.

## 3.2: Different Genetic Damages or Mutations

### Learning Objectives

- 1: Know different types of genetic damages or mutations.
- 2: Know how different mutations resulted in the cells by mutagens.

**Do you know how many mutations or damages are possible by mutagens in the cells?**

Mutations can be:

- Microlesions (gene mutation)
- Macro lesions (Chromosomal mutation)

### 2.1: Microlesions (Gene Mutation)

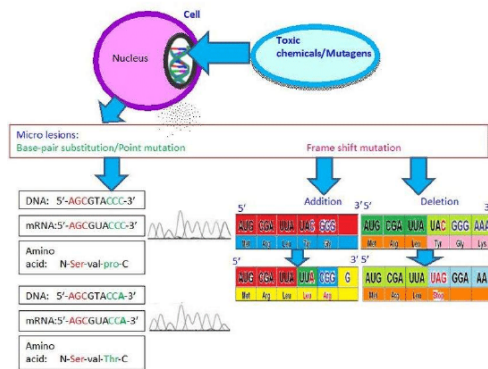

Microlesions are the damages or mutations in DNA bases. These mutations are with invisible phenotypic changes. The types of microlesions are illustrated in the figure on the right.

#### Base-pair substitution mutation (qualitative change in nucleotide pairs)

- In this mutation, single base nucleotide is replaced by another nucleotide.

#### Frame shift (quantitative change in nucleotide pairs)

- In this mutation, addition or deletion of nucleotide in the DNA sequence resulted to shift or change the entire DNA or amino acid sequence.

Figure 3.2.1: Micro lesions mutation by mutagens.

### 2.2 Macro Lesions (Chromosomal Mutation)

Macro lesions are chromosomal mutations with mutagens and are with distinct morphological changes in the phenotype. These morphological changes of chromosomes can be cytologically visible under microscope. Macro lesions are following types:

#### Numerical changes in chromosomes

- Polyploidy: Duplication of entire set of chromosome to triploid or tetraploid.
- Aneuploidy: Changes of single missing chromosome to **monosomy** or three copies of a single chromosome to **trisomy**.

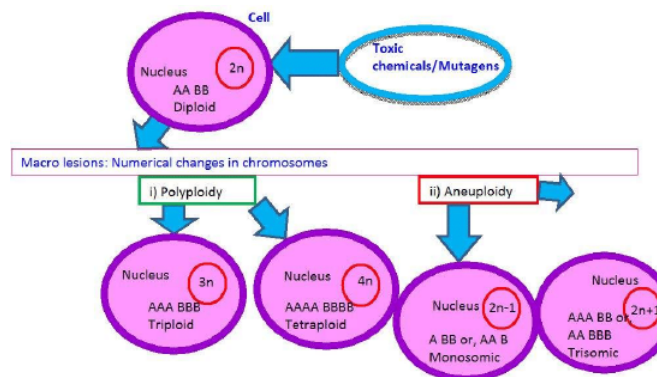

Figure 3.2.2: Macro lesions mutation by mutagens.

#### Structural changes in chromosomes

- Deletion: loss of chromosome segment
- Translocation: A segment of one chromosome becomes attached to a non homologous chromosome. It can be one way transfer as simple translocation and two way transfer as reciprocal translocation.
- Inversion: A change in the direction of material along a single chromosome.



- Duplication: Repetition of chromosome segment

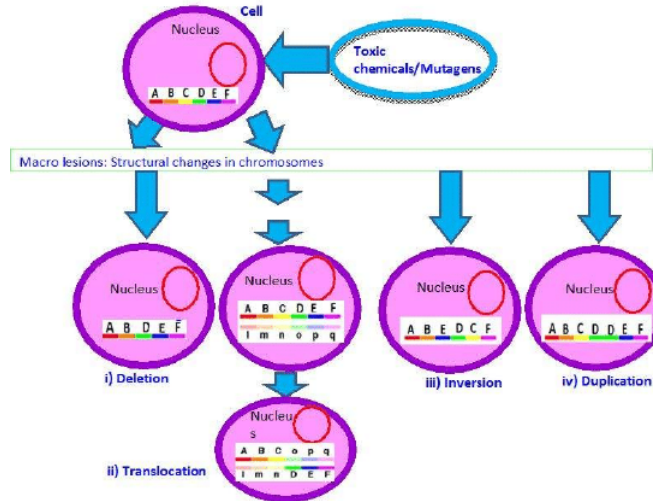

Figure 3.2.3: Structural changes in chromosomes resulted to macro lesions mutation.

### Micronuclei changes

- Micronuclei (MN) are the damaged chromosome fragments or whole chromosomes that were not incorporated into the cell nucleus and stayed as the extra-nuclear bodies after the cell division.
- MN can be resulted by the defects of the cell repair machinery and by the accumulation of damaged DNA and chromosomal aberrations.[genetic.html](http://genetic.html)

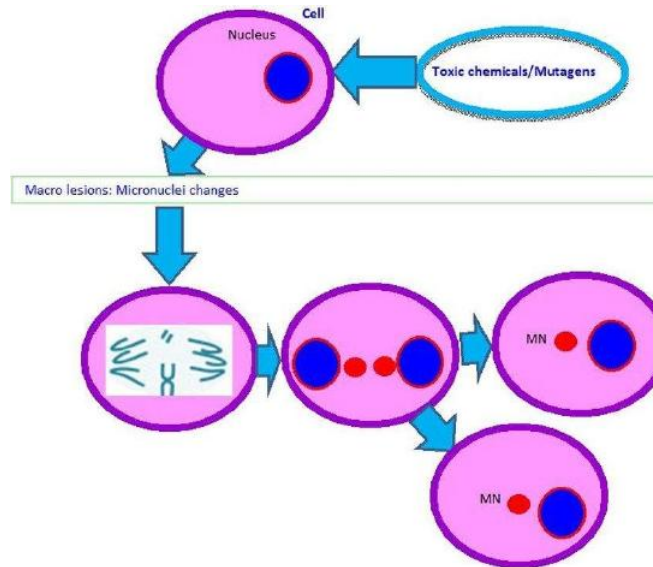

Figure 3.2.4: Micronuclei changes resulted to macro lesions mutation.

### Topic 2: Key Points

In this section, we explored the following main points:

- 1: Different types of Microlesions (gene mutation) and Macro-lesions (Chromosomal mutation).
- 2: How toxic agents or mutagens modulate the two different microlesions namely base pair substitution and frame shift mutation.
- 3: Genotoxic mutagens involve also in different macro-lesions namely numerical or structural changes in chromosomes or changes of micronuclei in cell.

**Knowledge Check**

1. What is monosomy?

- Duplication of entire set of chromosome .
- Single missing chromosome from diploid set.
- Three copies of a single chromosome.

**Answer**

Single missing chromosome from diploid set.

2. In base-pair substitution mutation, single base nucleotide is replaced by another nucleotide.

- True
- False

**Answer**

True

3. What are the structural changes in chromosomes caused by toxicants?

- Deletion
- Translocation
- Inversion
- Duplication
- All of the above

**Answer**

All of the above

4. Micronuclei (MN) changes are the damaged chromosome fragments or whole chromosomes that were not incorporated into the cell nucleus and stayed as the extra-nuclear bodies after the cell division.

- True
- False

**Answer**

true

5. Frame shift mutation, resulted to shift or change of entire DNA or amino acid sequence by:

- addition of nucleotide in the DNA.
- deletion of nucleotide in the DNA.
- addition or deletion of nucleotide in the DNA

**Answer**

addition or deletion of nucleotide in the DNA

### 3.3: Different Genetic-Toxicology Assays

#### Learning Objectives

- 1: Know different types of genetic-toxicology assays
- 2: Know how different genetic-toxicology assays are used in toxicology when cells are exposed to mutagens.

The goal of genetic toxicology assay is to determine whether any chemical or mutagen will do any adverse effect on genetic material or may cause different diseases including cancer. The assays can be performed using bacterial, yeast, or mammalian cells. One can early control and save vulnerable organisms from genotoxic chemicals by performing genetic toxicology assay.

The following different types of genetic toxicology assays are used now a days:

- Bacterial Reverse Mutation Assay (Ames Assay)
- Genetic mutation assay
  - Allele-Specific PCR
  - Sanger Dideoxy Sequencing
- Chromosome aberration study
- Micronucleus assay

#### 3.1: Bacterial Reverse Mutation Assay (Ames Assay )

This assay was discovered by Bruce Ames in 1970. This assay is widely used to test for gene mutation. The technique uses several strains of the bacterium *Salmonella typhimurium* which carry mutations in genes involved in histidine synthesis. These strains are auxotrophic mutants and they require histidine for growth and they cannot produce it. This assay examine the ability of the chemical or mutagen in creating mutations or a "prototrophic" state of strains, when the strains can grow on a histidine-free medium.

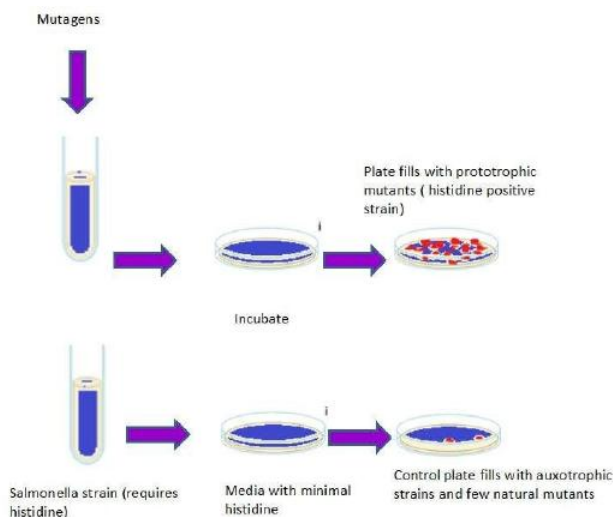

Figure 3.3.1: Ames test

#### 3.2: Genetic Mutation Assay

Following are the different molecular assay to study nucleotide variants or alternation of genetic material caused by mutagens:

##### Allele-Specific PCR

Single nucleotide polymorphism (SNP) resulted from base substitution mutation can be analyzed by this method. In this real-time PCR, fluorescent reporter probes are added to the reaction mixture and one fluorescent reporter probe is selected for wild type and other fluorescent probe is used for mutant. The PCR primers with fluorescent probe will match or mismatch one of the alleles at 3'

end of the primer. DNA polymerase extends the probes in a complementary fashion and releasing the reporter fluorescent molecules for detection. The PCR cycles with the reporter probes show the amplified signals and allow for precise measurement of one or both alleles of interest. Similarly, the 3' end of the mutant-specific primer is extended only in the presence of DNA with that mutation.

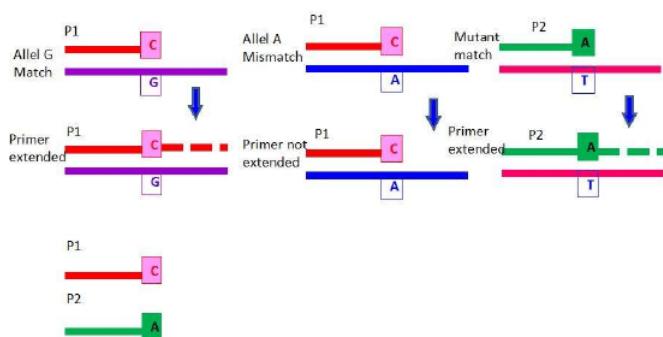

### Sanger Dideoxy Sequencing

The goal of this method is to detect unknown mutations including single nucleotide variants (SNVs) and small duplications, insertions, deletions, and indels of interest caused by mutagens. In this method, sequencing primers hybridized to the PCR product and are extended using the four deoxynucleotides (dNTPs), a mixture of fluorescently labeled dideoxynucleotides (ddNTPs) and DNA polymerase. Four ddNTPs are marked with a different fluorescent dye. Random incorporation of the marked ddNTPs shows in termination of strands at each location along the sequence. The gel electrophoresis separates the strands by size. Fluorescence spectroscopy measured the terminating nucleotides.

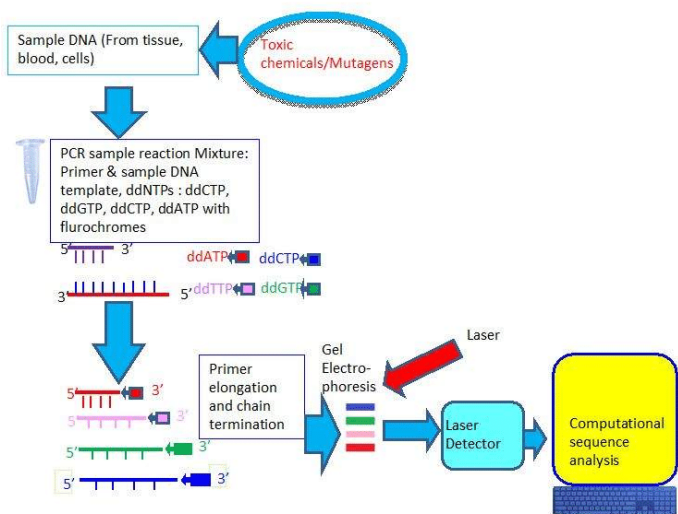

### 3.3: Chromosome Aberration Study

Cytogenetic assays of mammalian cells are performed to detect different types of structural and numerical chromosomal aberrations caused by genotoxic chemicals. The clastogenic or aneugenic effects from the genotoxic chemicals will result in an increase in frequency of structural (premature centric separation, chromosome breaks, dicentric chromosomes, ring) complex rearrangements (Figure 4) or numerical aberrations of the genetic material in mammalian cells.

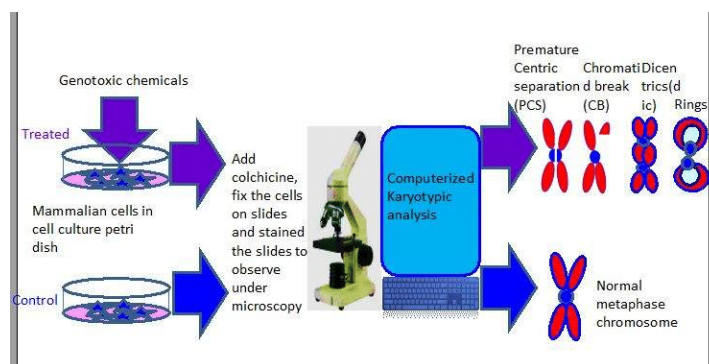

Figure 3.3.2: Chromosome aberration study

### 3.4: Micronucleus Assay

Micronucleus assay is used as a tool to evaluate genetic damage caused by genotoxic chemicals. The number of micronuclei (Figure 5) generated directly relates to the amount of DNA damage in the cells.

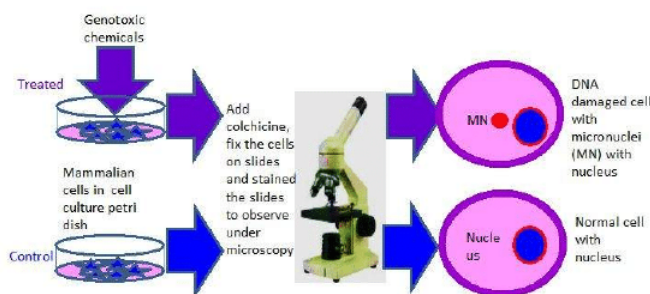

Figure 3.3.3: Micronucleus assay

#### Topic 3: Key Points

In this section, we explored the following main points:

- 1: Definition of genetic toxicology assay
- 2: Different types of genetic-toxicology assays.
- 3: How genetic mutation assays are performed by Allele-Specific PCR and Sanger Dideoxy Sequencing techniques.
- 4: What are the different types of chromosomal aberrations observed under microscope by chromosome aberration study?
- 5: Changes of micronuclei observed under microscope by Micronucleus assay.

#### Knowledge Check

1. Cytogenetic assays of mammalian cells are performed to detect different types of structural and numerical chromosomal aberrations caused by a genotoxic chemicals. The structural chromosomal aberrations are:

- premature centric separation
- ring
- chromosome breaks
- dicentric chromosomes
- All of the above

#### Answer

All of the above

2. In Allele-Specific PCR, fluorescent reporter probes are added to the reaction mixture and one fluorescent reporter probe is selected for wild type and other fluorescent probe is used for mutant.

True

False

**Answer**

True

3. Which instrument is used to measure the terminating nucleotides in Sanger Dideoxy Sequencing?

Fluorescence spectroscopy

Spectrophotometer

Fluorescence microscopy

None of the above

**Answer**

Fluorescence spectroscopy

4. The Ames technique uses several strains of the bacterium *Salmonella typhimurium* which carry mutations in genes involved in:

Arginine Synthesis.

Histidine synthesis.

Lysine Synthesis.

None of the above.

**Answer**

Histidine synthesis.

This page titled [3.3: Different Genetic-Toxicology Assays](#) is shared under a [CC BY-NC 4.0](#) license and was authored, remixed, and/or curated by [ToxMSDT Online component](#) via [source content](#) that was edited to the style and standards of the LibreTexts platform.

## 3.4: Different Cytotoxicity Assays

### Learning Objectives

- 1: Know different types of cytotoxicity assays.
- 2: Know how different cytotoxicity assays are used when cells are exposed to toxicants or mutagens.

The goal of cytotoxicity assay is to determine whether any chemicals or drugs will do any toxic effect or load on milieu or genetic material of the cells caused for lethality of the cells or caused for different diseases.

The following are the different types of cytotoxicity assays:

- DNA fragmentation/ladder assay
- Comet assay
- Necrosis assay
- Enzyme assay
- Proteomics assay
- Expression array assay

### 4.1: DNA Fragmentation/Ladder Assay

DNA fragmentation or ladder assay are used to know the fragmented DNA of the cells caused by chemicals or drugs. Fragmented DNA can be separated by agarose gel electrophoresis and can be visualized as “ladder” by ethidium bromide staining. The evaluation of cytotoxicity through cell death is an acceptable common assessment.

Ladder assays are performed for the following reasons:

1. to simply characterize the toxicity of the chemicals or drugs in cells, or
2. to determine the maximum doses of the test chemicals or drugs that can be used for cells without causing too much cell death.

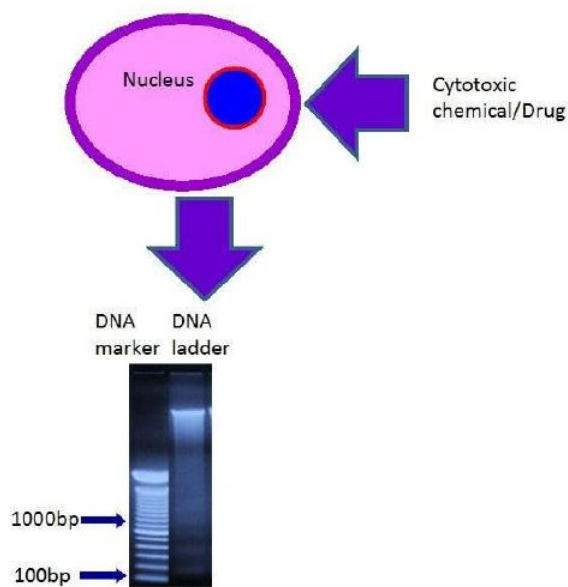

Figure 3.4.1: DNA ladder. Nucleotide base pair mentioned as, “bp”.

### 4.2: Comet Assay

The Comet Assay (single cell gel electrophoresis /SCGE) is used to detect DNA damage by using a micro gel electrophoresis. The image of the damaged DNA shows a comet with head and tail. The analysis of image for comet assay is calculated for the “tail length” of the comet which is the measurement from the point of highest intensity within the comet head as well as the “tail moment” which is the product of the tail length and the fraction of total DNA present within the tail.

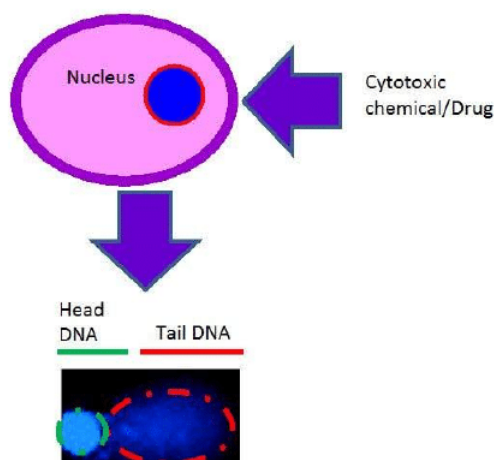

Figure 3.4.2: Comet assay showed amount of damaged DNA by comet tail moment.

### 4.3: Necrosis Assay

The necrosis assay is performed by flow cytometry analysis with staining of Annexin V and propidium iodide (PI) in the cells. The cells are considered in the stage of necrosis if the cells lose membrane integrity and die promptly due to cell lysis when exposed to chemicals, drugs, toxins or foreign antigens. In necrosis, cells show swelling, loss of membrane integrity and disruption of metabolism. Cells with necrosis do not go to stage of apoptosis, apoptotic cell may undergo secondary necrosis. These necrotic cells will shut down metabolism, lose membrane integrity, lyse and formed cell injury autolysis.

The flow cytometric analysis for necrosis assay showed that the cells stained positive for both FITC Annexin V and PI are in the end stage of apoptosis and are undergoing to the stage of necrosis as dead cells stained PI positive. Cells that stain negative for both FITC Annexin V and PI are alive and not undergoing apoptosis or necrosis.

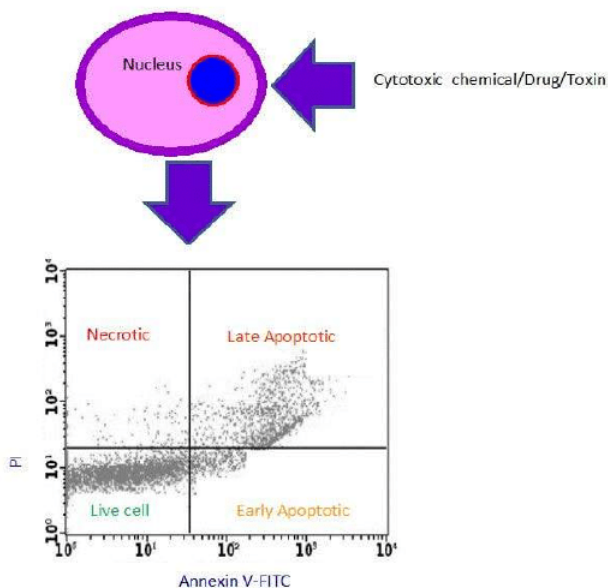

Figure 3.4.3: Flow cytometry analysis of cells showing necrosis stage.

### 4.4: Enzyme Assay

The enzyme assay is used to monitor passaging of lactate dehydrogenase (LDH), due to loss of cell membrane integrity when cells are exposed to cytotoxic compounds. LDH reduces NAD to NADH which generates a color change by interaction with a specific probe (Figure 4a). In other enzyme assay, Adenosine triphosphate (ATP)-based assay combined with bioluminescent assay are used to measure cytotoxicity of the cells in which ATP is the reagent for the luciferase reaction.



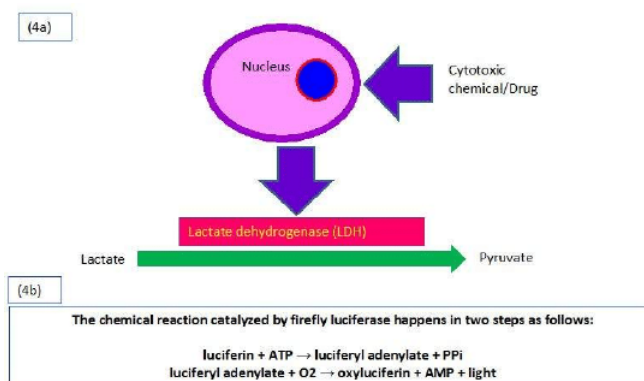

Figure 3.4.4: Schematic presentation of enzyme assay. (a) LDH assay (b) ATP based assay

#### 4.5: Proteomics Assay

The proteomic assay is performed to know the mechanism of cellular toxicity by measuring expression of a specific protein which may consider as a biomarker for particular toxic mechanism or cellular toxicity signaling pathway. Immunofluorescence, immunoprecipitation and immunoblot assay are mainly used to know the effect of toxicants in cellular toxicity signaling pathway or mechanism.

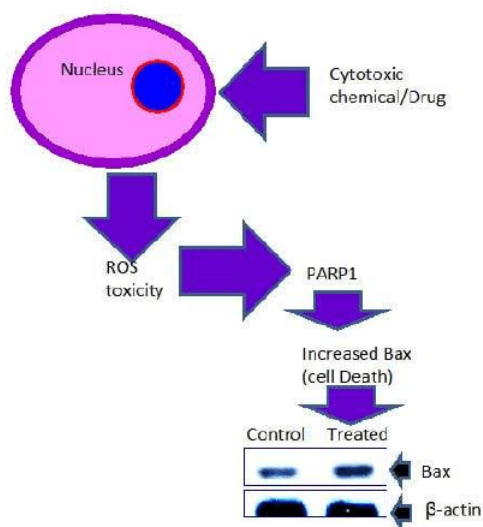

Figure 3.4.5: Schematic presentation of proteomic assay.

#### 4.6: Expression Array Assay

The expression array is the chip based microarray of more gene expressions (finger print of genes) by the effect of cellular toxicants. This is a rapid and sensitive detection method which allows to detect all toxicological end points at wide range of molecular level changes in the cell at single assay. The microarray process can be divided into two main parts. First is the printing of known gene sequences onto glass slides or other solid support followed by hybridization of fluorescently labeled cDNA (containing the unknown sequences to be interrogated) to the known genes immobilized on the glass slide. After hybridization, arrays are scanned using a fluorescent microarray scanner. Analyzing the relative fluorescent intensity of different genes provides a measure of the differences in gene expression.

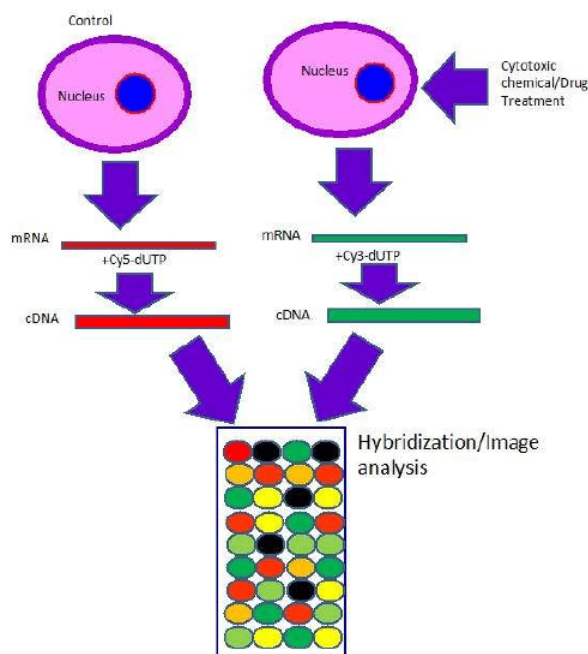

Figure 3.4.6: Schematic representation of gene expression array showed that Cy5(red) and Cy3 (green) labeled cDNA hybridized to a DNA microarray. Yellow spots indicate the genes are expressed in both samples. The intensity and different types of color at each spot indicate the level and presence of genes in samples. Black spots show low level of expression or do not show any expression of genes.

#### Topic 4: Key Points

In this section, we explored the following main points:

- 1: Different types of cytotoxicity assays.
- 2: How different cytotoxicity assay namely DNA fragmentation/ladder assay, Comet assay, Necrosis assay, Enzyme assay, Proteomics assay, and Expression array assay are used when cells are exposed to cytotoxic agents.

#### Knowledge Check

1. The cells are considered in the stage of necrosis, if the cells lose membrane integrity and die promptly due to cell lysis when exposed to chemicals, drugs, toxins or foreign antigens.

True

False

**Answer**

True

2. The Comet Assay is used to detect DNA damage by using a micro gel electrophoresis:

True

False

**Answer**

True

3. The expression array is the chip based microarray of more gene expressions (finger print of genes) by the effect of cellular toxicants.

True

False

**Answer**

True

4. Ladder assay are performed for the following reasons: 1) to simply characterize the toxicity of the chemicals or drugs in cells, or 2) to determine the maximum doses of the test chemicals or drugs that can be used for cells without causing too much cell death.

True

False

**Answer**

True

5. What are the proteomic assays to know the effect of toxicants in cellular toxicity signaling pathway or mechanism?

Immunofluorescence assay

ring

Immunoprecipitation assay

Immunoblot assay

All of the above

**Answer**

All of the above

This page titled [3.4: Different Cytotoxicity Assays](#) is shared under a [CC BY-NC 4.0](#) license and was authored, remixed, and/or curated by [ToxMSDT Online component](#) via [source content](#) that was edited to the style and standards of the LibreTexts platform.

## 3.5: Epigenetics Assay

### Learning Objectives

- 1: Know different types of epigenetic assays.
- 2: Know how different epigenetic assays are used when cells are exposed to toxicants or mutagens.

### 5.1: DNA Methylation Assay

DNA methylation assays are important to know the epigenetic modification which is a heritable, enzyme-induced modification without alteration of the nucleotide base pairs. The transfer of a methyl-group to the 5-carbon on the cytosine in a CpG dinucleotide happens in the DNA methylation by DNA methyltransferases (DNMT1, DNMT3A, and DNMT3B). The high level of promoter CpG island methylation results in gene silencing. The methylated DNA immunoprecipitation (MeDIP)-chip technique is used for DNA methylation assay.

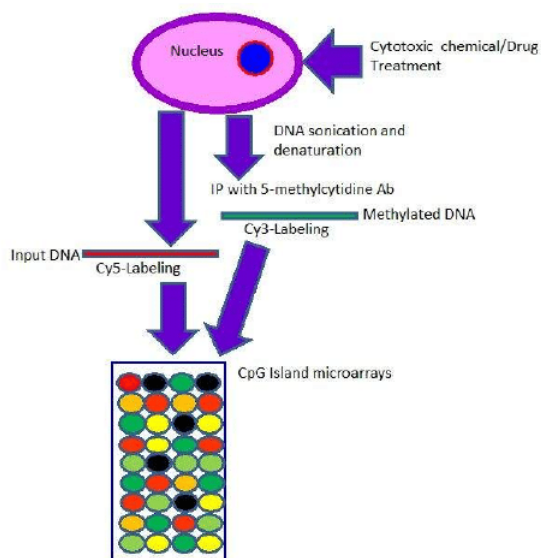

Figure 3.5.1: Schematic diagram of MeDIP protocol for DNA methylation assay.

In brief, the MeDIP-chip procedure is mentioned as follows. The genomic DNA is sheared to low molecular weight fragments (approximately 400 bp) by sonication. Then, the methylated DNAs are immunoprecipitated with the anti-methyl-cytosine antibody, and are amplified with PCR, if source material is less. Input and methylated DNA are labeled with fluorescent dyes Cy3 (green) and Cy5 (red), pooled, denatured, and are hybridized to a microarray slide containing all the annotated human CpG islands or other whole genome or promoter microarray designs. Then the slide is scanned using a scanner and each image is analyzed with the image analysis software ( Figure 1).

### 5.2: Histone Modification Assay

Histone modification assays are useful to find the modification of histone proteins (e.g. lysine acetylation, lysine and arginine methylation, serine and threonine phosphorylation, and lysine ubiquitination and sumoylation) which have important roles in epigenetic inheritance. The chromatin immunoprecipitation (ChIP) assay followed by hybridization to microarrays (ChIP-chip) (left) or by high-throughput sequencing (ChIP-seq) (right) are both powerful techniques to find histone modification.

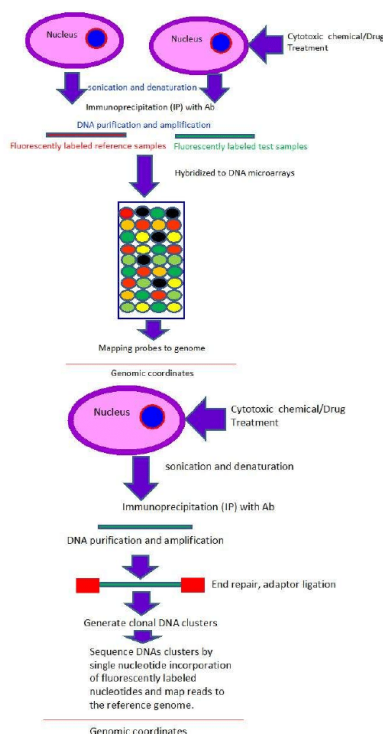

Figure 3.5.2: Schematic presentation of ChIP – chip microarray and seq of histone modification assay

### 5.3: MicroRNAs Assay

MicroRNAs assays are used to know the non-coding RNAs (17-25 nucleotides) which target messenger RNAs (mRNAs) and decayed the mRNAs or downregulated at the level of translation into protein. Almost, 60% of human protein coding genes are controlled by miRNAs and these miRNAs are epigenetically regulated. About 50% of miRNA genes are related with CpG islands, which may be repressed by epigenetic methylation. Other miRNAs are epigenetically controlled by either histone modifications or by DNA methylation. The expression of microRNAs are quantified by RT-PCR followed by quantitative PCR (qPCR). Then, miRNAs are hybridized to microarrays, slides or chips with probes to hundreds or thousands of miRNA targets. The microRNAs can be both invented and profiled by sequencing methods (microRNA sequencing).

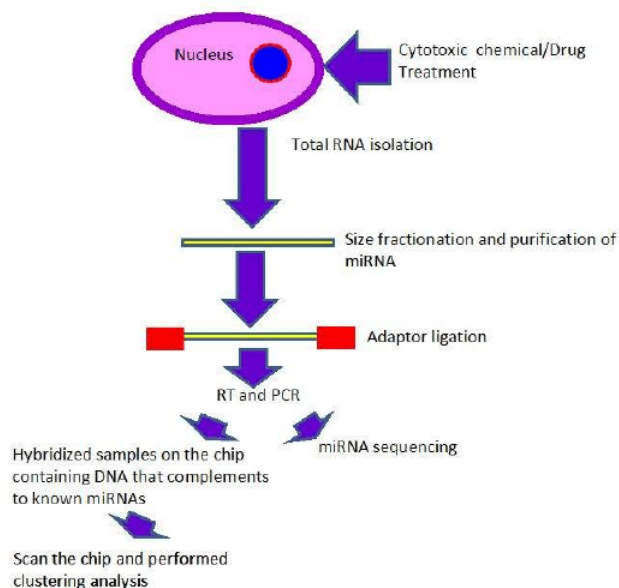

Figure 3.5.3: Schematic presentation of miRNA assay in epigenetic toxicology

### Topic 5: Key Points

In this section, we explored the following main points:

- 1: Different types of Epigenetic assays.
- 2: How different Epigenetic assays namely DNA methylation assay, histone modification assay and MicroRNAs assay are used when cells are exposed to toxic chemicals or agents.

#### Knowledge Check

1. DNA methylation assays are important to know the non-epigenetic modification.

True

False

**Answer**

false

2. MicroRNAs assays are used to know the non-coding RNAs. These non-coding RNAs are :

17 to 25 nucleotides.

50 to 100 nucleotides.

200 to 400 nucleotides.

None of the above.

**Answer**

17 to 25 nucleotides.

3. Histone modification assays are useful to find the modification of histone proteins which have important roles in epigenetic inheritance:

True

False

**Answer**

true

This page titled [3.5: Epigenetics Assay](#) is shared under a [CC BY-NC 4.0](#) license and was authored, remixed, and/or curated by [ToxMSDT Online component](#) via [source content](#) that was edited to the style and standards of the LibreTexts platform.

## Section 3 Final Evaluation

---

1. \_\_\_\_\_ is a method used in analyzing base substitution mutation resulting from single nucleotide polymorphism.

- Micronucleus assay
- Chromosome aberration study
- Allele-Specific PCR
- Chromatography

**Answer**

Allele-Specific PCR

2. Proteomic assay analyzes the effect of toxicants in cellular toxicity signaling pathways or mechanisms through:

- Immunofluorescence
- Immunoblot
- Immunoprecipitation
- All of the above

**Answer**

All of the above

3. In Ladder Assay, fragmented DNA can be separated by agarose gel electrophoresis and can be visualized as “ladder” by \_\_\_\_\_ staining.

- Ethidium bromide
- Eosin
- Gram
- Wright’s

**Answer**

Ethidium bromide

4. Trisomy is a form of aneuploidy interpreted as:

- Single missing chromosome from diploid set.
- Three copies of a single chromosome from a diploid set
- Three copies of a single chromosome from a triploid set
- Single missing chromosome from a triploid set

**Answer**

Three copies of a single chromosome from a diploid set

5. Gene mutations in which a single base nucleotide is replaced by another nucleotide are known as:

- Frame shift
- Quantitative change in nucleotide
- Qualitative change in nucleotide
- Left shift

**Answer**



Qualitative change in nucleotide

**6. Some structural chromosomal aberrations caused by genotoxic chemicals in cytogenetic assays of mammalian cells include the following EXCEPT:**

- Dicentric Chromosomes
- Ring Chromosomes
- Spiral Chromosomes
- Chromosome breaks

**Answer**

Spiral Chromosomes

**7. Structural changes in chromosomes include the following EXCEPT:**

- Aneuploidy
- Inversion
- Translocation
- Deletion

**Answer**

Aneuploidy

**8. Addition or deletion of nucleotides in the DNA sequence results in the change of the entire DNA or amino acid sequence. This process is known as:**

- Frame shift
- Base-pair substitution mutation
- Qualitative change in nucleotide
- Right shift

**Answer**

Frame shift

**9. In Allele-Specific PCR, fluorescent reporter probes are added to the reaction mixture, one fluorescent reporter probe is selected for the wild type and the other fluorescent probe is used for the mutant.**

- True
- False

**Answer**

true

**10. The analysis of image to determine DNA damage in comet assay is calculated for the \_\_\_\_\_ and \_\_\_\_\_.**

- “tail length” and “head length”
- “head length” and “head moment”
- “head length” and “tail moment”
- “tail length” and “tail moment”

**Answer**

“tail length” and “tail moment”

**11. Cells which stain negative for both fluorescein isothiocyanate Annexin V and propidium iodide in flow cytometric analysis for necrosis assay are:**

- Dead and undergoing apoptosis and necrosis
- Alive and not undergoing apoptosis or necrosis
- Dead and undergoing necrosis only
- Alive and undergoing apoptosis only

**Answer**

Alive and not undergoing apoptosis or necrosis

**12. Histone Modification Assay uses Chromatin immunoprecipitation assay (ChIP) followed by:**

- Hybridization to microarrays (ChIP-chip)
- Immunofluorescence
- Fluorescence spectroscopy
- Fluorescence microscope

**Answer**

Hybridization to microarrays (ChIP-chip)

---

This page titled [Section 3 Final Evaluation](#) is shared under a [CC BY-NC 4.0](#) license and was authored, remixed, and/or curated by [ToxMSDT Online component](#) via [source content](#) that was edited to the style and standards of the LibreTexts platform.

## CHAPTER OVERVIEW

### 4: Applied Systems Toxicology

Systems toxicology is a branch of science that utilizes data from different branches of toxicology and integrates them to provide a holistic approach for safety assessment. In this e-module you will learn about the concept of systems toxicology, dose level in toxicology, and different approaches to traditional and new toxicology.

[4.1: Systems Toxicology](#)

[4.2: Dose Level and Applied Toxicology](#)

[4.3: Tools and Technologies in Systems Toxicology](#)

[4.4: Other Approaches for Predictive Toxicity Modeling](#)

[4.5: Technologies Used In Systems Biology/Toxicology](#)

[4.6: Takeaways Summary](#)

[Section 4 Final Evaluation](#)

---

This page titled [4: Applied Systems Toxicology](#) is shared under a [CC BY-NC 4.0](#) license and was authored, remixed, and/or curated by [ToxMSDT Online component](#) via [source content](#) that was edited to the style and standards of the LibreTexts platform.

## 4.1: Systems Toxicology

### Learning Objectives

- 1: Understand the concept of systems toxicology.
- 2: Understand the approaches of traditional toxicology approaches vs. the new toxicity testing paradigm.
- 3: Recognize the driving force behind the growth of this field.
- 4: Applications of this field.

The word “systems” originates from the Latin word “systema” which means a complete concept that has several parts. Similarly systems toxicology is a branch of science that utilizes data from different branches of toxicology and integrates them to provide a holistic approach for safety assessment.



Toxicology is the science of understanding the adverse effects of xenobiotics (drugs, chemicals, etc.) on biological systems. Biological systems are extremely complex. Due to the vast number of toxicology research approaches over the years, and a lot of data have been generated in different systems- in vivo, in vitro, in silico (especially due to “omics” approaches). However, there is currently a lack of interpreting/utilizing that data for efficient safety assessment of xenobiotics.

Systems toxicology aims to fill this gap and utilize these data from different systems and integrate them into meaningful assessment for safety. It relies heavily on mathematical and computational models to link the data from various systems. So, in order to have fully validated systems toxicology approaches it is important to have “real” (in life) data from animal models to validate the hypothesis.

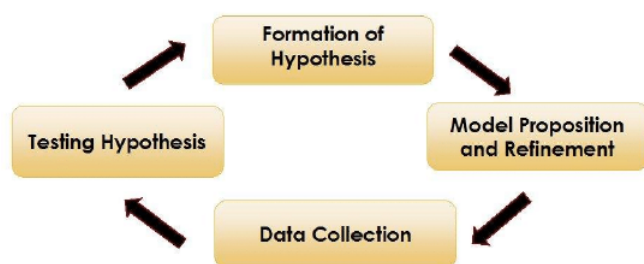

### The Driving Force

The main driving force behind the development of systems toxicology approaches is the fact that the whole “safety assessment” process is a very lengthy, time consuming and expensive process in case of chemicals as well as the pharmaceutical industry. In order to make this process more efficient, it is important for early pharmaceutical/chemical (especially pharmaceuticals) candidate selection/screening. Screening thousands of compounds is a lengthy process and current high-throughput screening approaches together with large volume data analysis techniques have helped in more efficient selection of target molecules.



### Topic 1: Key Points

In this section, we explored the following main points:

- 1: The concept of systems toxicology and the different approaches and the driving force behind the development of this field.

#### 📌 Knowledge Check

1. Systems toxicology is usually applicable in the ...

Early discovery phases of drug development

During marketing of the drug

During regulatory safety testing phases

None of the above

#### Answer

Early discovery phases of drug development

2. Systems toxicology approach involves...

Traditional animal experiments

Alternative in vitro methods

Computational and mathematical models

All of the above

#### Answer

All of the above

This page titled [4.1: Systems Toxicology](#) is shared under a [CC BY-NC 4.0](#) license and was authored, remixed, and/or curated by [ToxMSDT Online component](#) via [source content](#) that was edited to the style and standards of the LibreTexts platform.

## 4.2: Dose Level and Applied Toxicology

### Learning Objectives

After completing this lesson, you will be able to:

- 1: Assess toxicity in response to dose levels.

As students of toxicology it is critically important to understand that everything including water and oxygen has the potential to act as poison. It is only the dose that determines the toxic/beneficial effect.

### Dose level and Applied Toxicology

While traditional toxicology approaches in many academic laboratories and also in industry utilized very high dose levels of xenobiotics in order to study various mechanisms of toxicity, it has been identified recently that this is not a very ideal approach especially for industrial applications.

#### Step 1 Title

- Using very high dose levels may saturate the physiological processes in a living system and hence may cause “forced toxicity” which is not very relevant in terms of real life exposures (could be valid in case of overdose/accidental overexposure).

In industry, a lot of preliminary research is conducted in order to determine dose levels for toxicology experiments. Typically, in case of pharmaceutical compounds a lot of pharmacokinetic modeling and simulations is performed to come up with exposure levels that are multiples of the real drug exposure level in humans. In the chemical industry relevant exposure levels that human beings may be exposed to based on the use of the chemical is determined.

### Dose Level Selection

- 1: Traditional toxicity testing involved using a large number of animals and using very high dose levels. Study designs such as LD 50 (Lethal Dose for 50% animals in the study) are no longer used. It is not feasible from a scientific or animal welfare point of view
- 2: Nowadays, dose level selection often involves mathematical simulation and modeling utilizing various forms of in vitro data that are analyzed with the help of medium and high-throughput modeling tools. This is a systems toxicology approach where data from different platforms is utilized to come up with relevant dose levels that are scientifically justifiable and also to refine and minimize animal experiments.

### Schematic Approach: Systems Toxicology

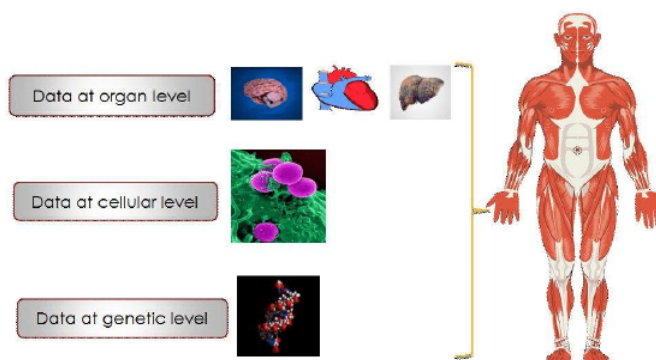

Figure 4.2.1: Schematic Approach: Systems Toxicology. Credit: pixabay.com

#### Key Points

In this section, we explored the following main points:

- 1: The understanding of how toxicity is driven strongly by the dose response relationship.

 Knowledge Check

1. Utilizing very high dose levels in animal models are not useful because

It causes forced toxicity due to saturation of the absorption and elimination processes

It is too toxic and no meaningful information is available from such data

It is necessary for planning acute studies

It causes a lot of wastage of test article

**Answer**

It causes forced toxicity due to saturation of the absorption and elimination processes

2. Traditional LD 50 studies evaluated...

Adverse effects in 50 animals per dose group

Death in 50 % of the population

Effects in 50% of the animal population

Doses to be used in subsequent chronic studies

**Answer**

Death in 50% of the population

This page titled [4.2: Dose Level and Applied Toxicology](#) is shared under a [CC BY-NC 4.0](#) license and was authored, remixed, and/or curated by [ToxMSDT Online component](#) via [source content](#) that was edited to the style and standards of the LibreTexts platform.



## 4.3: Tools and Technologies in Systems Toxicology

### Learning Objectives

- 1: Understand tools and technologies used in systems toxicology, the concept of adverse effects and Adverse Outcome Pathways.

### Tools and Technologies



1. Tools at the molecular level: Omics technologies such as genomics, proteomics, metabolomics.
2. Tools at the cellular level include highly refined high-throughput *in vitro* model systems.
3. Modeling softwares that can utilize *in vitro* data and mathematically translate that into relevant *in vivo* information utilizing pharmacokinetic (PK) or physiologically based pharmacokinetic models (PBPK). This is known as *in vitro* to *in vivo* extrapolation (IVIVE).
4. Modeling softwares that can perform sophisticated species scaling (prediction of human parameters from nonclinical species such as rat, dog, monkey, etc.)

5. Risk assessment and exposure modeling tools that enable calculation of hazard and risk in populations on a whole and specific subpopulations.

### Toxicity Testing in Chemicals vs. Pharmaceuticals

Regulatory based toxicity testing is different for pharmaceutical based compounds versus chemical and agrochemical compounds. Non clinical safety assessment for pharmaceutical products is governed by the different stages of drug development while the toxicological data requirement for chemicals/agrochemicals is based on the amount (tonnage) produced. While most pharmaceutical compounds undergo extensive animal toxicity testing, there are thousands of chemicals in commerce today that have undergone very limited or non toxicity testing. In order to address this several governmental mandates are being put into action.

### Government Initiatives & Mandates for 21st Century Toxicity Testing

- In Europe, the Registration Evaluation Authorization and Restriction of Chemicals (REACH) was initially implemented in 2007.
- This substantially altered the safety testing performed on new as well as existing chemicals.
- In The United States too several initiatives to increase safety testing on more and more chemicals are underway which would increase the cost of safety assessments astronomically.
- The regulations under REACH have been directly estimated to cost the industry more than 4.2 billion dollars (Brown, 2003).



Figure 4.3.1: Brown, V. J. (2003). REACHing for chemical safety. *Environ. Health Perspect.* 111, A766–A769.

## 21st Century Toxicity Testing

Traditional toxicity testing involves the use of a lot of animals and is an extremely expensive and time consuming process. In order to address the large number of untested chemicals the US Environmental Protection Agency (EPA) initiated the **ToxCast program**. The ToxCast Program is a high-throughput screening program that would enable the prioritization of chemicals so that resources can be channelized towards those chemicals that possess the greatest risk to human safety.

### THE TOXCAST PROGRAM



The ToxCast program developed and utilized automated *in vitro* assays ( to test effects of chemicals on various biological processes using living cells, isolated proteins etc.). The assay designs included endpoints such as cytotoxicity, enzyme activity, endocrine endpoints, gene expression etc. A total of approximately 600 endpoints were evaluated.

**The biggest question to answer was how relevant was this data to human safety and how to utilize this *in vitro* information to predict human safety.**

Figure 4.3.2: National Institute of Environmental Health Sciences – NIH, 50th Anniversary

#### The Overall Perspective

*In vitro* assays may be relevant in the light of the fact that overall disease/toxicology processes are actually mediated by molecular and cellular perturbations. However, the overall picture at the whole organism level includes several other complex factors such as pharmacokinetics of the compound, metabolism, clearance etc. This gap could be filled by utilizing computational modeling tools that would utilize the *in vitro* data and integrate them into human physiology with the help of pharmacokinetic (PK) or physiologically based pharmacokinetic models (PBPK).

#### Understanding the concept of effects Vs. adverse Effects

In order to conduct safety assessments it is important to understand the concept of “adverse effects” versus simply “effects”. It is also important to understand the significance of biological relevance of isolated *in vitro*, molecular assays as it pertains to the whole organism.

Adverse Outcome Pathways (AOPs) have been developed to try and link the causal molecular initiating event to a host of intermediate processes at the cellular level that finally leads to adverse outcome (AO) in the whole organism that can be used for safety assessment purposes.

#### Adverse Outcome Pathways

The AOP programme was launched by the Organization for Economic Co-operation and Development (OECD) in 2012. The objective was to link the main molecular initiating event with the phenotypic/functional toxicity/adverse effect at the organism level.



Figure 4.3.3: Adverse Outcome Pathways

#### Using Systems Toxicology Approach For Toxicity Predictions

The molecular initiating events could be used in selecting *in vitro* assays that could have possible potential for predicting toxicity at the whole organism level.

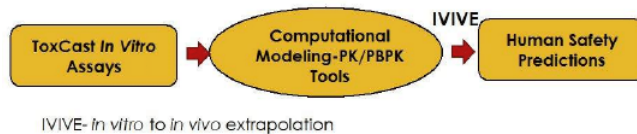

Figure 4.3.4: IVIVE- in vitro to in vivo extrapolation

### Topic 3: Key Points

In this section, we explored the following main points:

- 1: Tools and Technologies, used in the field of systems toxicology.
- 2: Concept of Adverse effects and AOPs .

#### 📌 Knowledge Check

1. The ToxCast program utilizes which kind of assays?

- In vivo
- In silico
- In vitro
- None of the above

#### Answer

in vitro

2. Adverse Outcome Pathway (AOP) Programme was launched by...

- National Toxicology Program (NTP)
- National Institute of Health (NIH)
- Environmental protection Agency (EPA)
- Organization for Economic Co-Operation and Development

#### Answer

Organization for Economic Co-Operation and Development

This page titled [4.3: Tools and Technologies in Systems Toxicology](#) is shared under a [CC BY-NC 4.0](#) license and was authored, remixed, and/or curated by [ToxMSDT Online component](#) via [source content](#) that was edited to the style and standards of the LibreTexts platform.

## 4.4: Other Approaches for Predictive Toxicity Modeling

### Learning Objectives

- 1: Understand what Quantitative Structure Activity Relationships are and how they are used in the field of systems toxicology.

### Quantitative Structure Activity Relationships (QSAR)

QSAR models are classification models that are used to link particular structures in some molecules to causative/adverse effects at cellular/organism level. This is based on the fact that compounds that are structurally similar would have similar mechanisms of mediating toxicity. For example compounds belonging to the structural class of triazoles have been reported to cause developmental malformations such as cleft palate in rats.

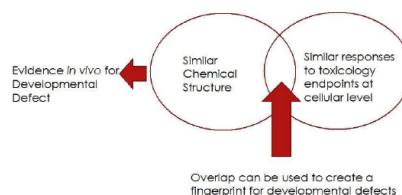

Figure 4.4.1: QSAR Approaches for Predictive Toxicity Testing

Mechanisms at the cellular level include events such as positive response for the TGFb1 signaling pathway. This information can be used to build a molecular fingerprint where compound having similar chemical structures as triazoles and having a positive response to TGFb1 signaling pathway could be flagged for potential developmental toxicity (teratogens).

### QSAR Approaches for Predictive Toxicity Testing

This method however requires a lot of data in order to build robust databases. This also requires validation of QSAR relationships with large sets of *in vitro* and *in vivo* datasets. This requires extensive collaboration between scientists across different disciplines of toxicology.

Currently, several softwares are available commercially that are used for predictive toxicology assessments. These softwares have been validated against compounds across different classes and various toxicological end points. Utilizing such tools requires detailed research and information on the extent of evaluation and validation conducted in order to develop these tools. For example softwares that have been validated with large data sets for pharmaceutical compounds may not be appropriate for using in a chemical space and vice versa.

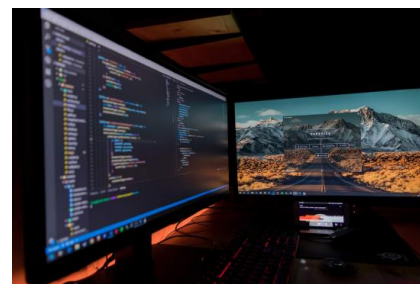

### Names of certain commercially available Computational Tools Used In Industry

- QSAR tools: Derek, GastroPlus, ADMET Predictor, OECD QSAR Toolbox, ACD ToxSuite
- PK/PBPK Modeling Tools: GastroPlus, Simcyp, WinNonlin, Berkeley Madonna

### Topic 4: Key Points

In this section, we explored the following main points:

- 1: The application of QSARS in systems toxicology.

### Knowledge Check

1. QSAR databases link:

Relationship between chemical structures of compounds and their activity/toxicity

Relationship between different responses at different organizational levels

Physiologically relevant modeling tools

In vitro to in vivo extrapolation

**Answer**

Relationship between chemical structures of compounds and their activity/toxicity

2. Development of efficient QSAR tools depend on...

The user's familiarity with the software/tool

Knowledge of multiple QSAR models

A large database of validation training sets

All of the above

**Answer**

A large database of validation training sets

---

This page titled [4.4: Other Approaches for Predictive Toxicity Modeling](#) is shared under a [CC BY-NC 4.0](#) license and was authored, remixed, and/or curated by [ToxMSDT Online component](#) via [source content](#) that was edited to the style and standards of the LibreTexts platform.

## 4.5: Technologies Used In Systems Biology/Toxicology

### Learning Objectives

- 1: Understand the different omics technologies and how they are used.

"Systems biology/toxicology uses very powerful high-throughput platforms/tools such as the “omics” technologies. The human genome was first sequenced in 2003. It took 13 years and was extremely expensive. Advancement in technology has now made it possible to have genome sequencing completed in less than a day. It has also made handling and interpretation of large volumes of data at different levels (gene, transcriptome, protein, metabolic) possible. Scientists across different disciplines are now using these technologies to provide a more holistic approach to disease and toxicity."

*Systems Biology in Toxicology and Environmental Health; First Edition, Chapter 1*

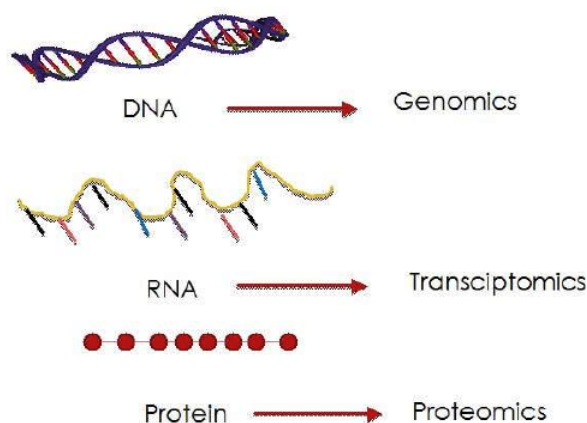

Figure 4.5.1: A schematic approach for “omics” technologies. Parts of illustration from [www.pixabay.com](http://www.pixabay.com)

### Technologies Used In Systems Biology/Toxicology

**Genomics:** This refers to the technology which allows us to study the complete genetic material of an organism. This involves DNA sequencing and analysis. Some of the most common methods used for high-throughput genotyping for genome wide association studies (GWAS) include Illumina Omni Arrays which can simultaneously analyze upto 5 million markers per sample. Other examples are the HumanOmni 5 Quad (Omni 5) and the Affymetrix platforms.

**GWAS:** A GWAS involves analysis of genetic variants in different individuals to study particular traits associated with genetic variations. This enables scientists to study the underlying mechanisms of different diseases at the genomic level. Single base pair changes are the most common form of variants of the genome and are known as single nucleotide polymorphisms (SNP). While most of them are functionally harmless, rare ones can lead to changes at the protein level leading to functional impairment and diseases.

### Genomics: Example Application

SNPs that results in functional changes at the protein level thereby causing a difference in phenotype such as a disease state is known as a mutation. These are considered rare genetic variants. An example of a disease state is cystic fibrosis which is cause by multiple mutation in the CFTR gene. This was made possible by genotyping families that were affected by this disease and identifying markers (genetic variants) that could be linked to this disease. This is known as linkage analysis. This type of analysis was also successfully used to identify unique mutations that lead to rare diseases like Huntington’s disease. While this approach has been successful for rare diseases it has been a challenge to utilize this for more common disease states such as cancer, heart and liver disease etc.

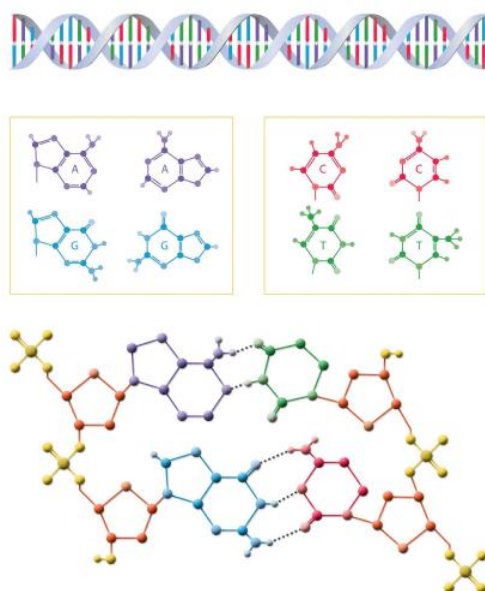

Figure \PageInde2: PLoS Comput Biol. 2012 Dec; 8(12)

## Transcriptomics

"Transcriptomics is the study of all transcriptomes (RNA) in a genome. In other words, it is the study that enables us to study large volumes (> 200,000) of data related to gene expression at the RNA level.

Traditionally RNA expression was studied through a technique known as Northern blots. But this technique could not handle large volumes of data. Current techniques used for high-throughput data analysis are different kinds of microarrays and biochips. The most commonly used are the DNA based microarrays.

Quantitative gene expression analysis helps us understand the difference in expression of genetic product between different cells, tissues, species etc. Such microarrays are commercially made available from companies like Affymetrix, Agilent, Applied Microarrays, Illumina etc."

*Systems Biology in Toxicology and Environmental Health; First Edition, Chapter 4*

### Different kinds of microarrays

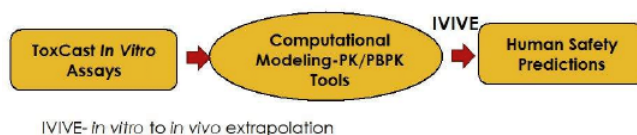
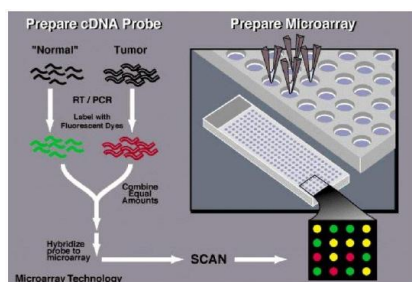

Figure 4.5.3: Different kinds of microarrays. Rebecca C. Fry. *Systems Biology in Toxicology and Environmental Health*, Chapter 4 (Kindle Location 1954). Elsevier Inc.

### Analysis of microarray data





Microarray data provides relative expression levels of various genes. Quantitative analysis of microarray data require sophisticated statistical tools and is expressed in the form of a “heat map” which provides expression patterns (upregulation/downregulation of genes) in the form of various colors. Significance analysis of microarrays (SAM is common technique) is a statistical tools that allows for quantitative determination of expression patterns.

Figure 4.5.4: Sample processing for microarrays. <https://www.genome.gov/10000533/dna-...ay-technology/>

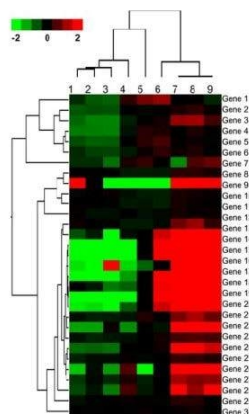

The output which is the heatmap has different colors signifying differential expression patterns. In the example given below red color signifies upregulated gene expression while green signifies downregulation.

Figure 4.5.5: Heatmap generated from microarray. Rebecca C. Fry. *Systems Biology in Toxicology and Environmental Health*, Chapter 4 (Kindle Location 1954). Elsevier Inc.

## Proteomics

"Proteomics is the field that studies total proteins in a system. This involves high-throughput profiling of proteins. This kind of expression pattern is especially useful since it allows us to study post translational effects, since all transcription products are not always converted to proteins; however, all functional aspects at the phenotypic level are almost always driven by proteins.

Proteomics is a powerful tool that can help us in identification of protein biomarkers specific to toxicity due to particular exposures or specific diseases states. Mass spectrometers are commercially sold by several companies such as Waters, Thermofisher, Agilent, Shimadzu, Perkin Elmer etc.

A mass spectrometer is used for analysis of proteomics data. Interpretation requires sophisticated bioinformatics tools."

Rebecca C. Fry. *Systems Biology in Toxicology and Environmental Health*, Chapter 4 (Kindle Location 1954). Elsevier Inc.

[Sample processing and workflow for proteomics studies:](#)

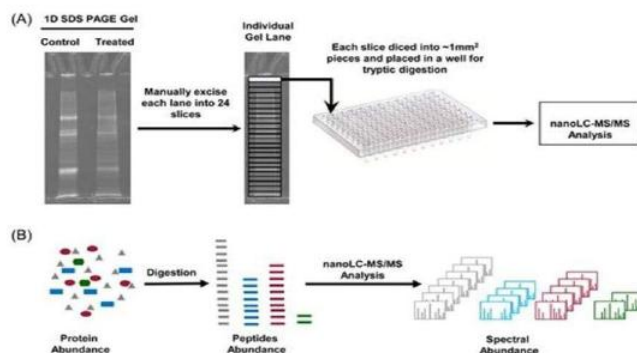

Figure 4.5.6: Sample processing and workflow for proteomics studies. Rebecca C. Fry. *Systems Biology in Toxicology and Environmental Health*, Chapter 4 (Kindle Location 1954). Elsevier Inc.

## Metabolomics

"Metabolomics refers to the study of metabolites (low molecular weight products of cellular /biological processes that are found in cells, tissues, biological fluids etc.). Metabolomics provides an understanding of the differences in the biochemistry between different variants (such as diseased and healthy patient populations, control group versus treatment group, high dose group versus low dose group etc.)

Metabolic profiling can be easily performed in biological matrices such as urine, blood, plasma, serum and also a wide variety of tissues. Hence this can be used very efficiently in human health and safety assessment for evaluating biomarkers for exposure to toxicity to various agents. It can be used in drug discovery in the pharmaceutical industry for comparing metabolic profile between different dose level and control groups. In the clinical setting metabolomics can provide an understanding of differences in metabolite products in diseased versus healthy patient populations.

Platforms/tools used in metabolomics is similar to proteomics. Liquid chromatography mass spectrometers (MS) are broadly used for metabolite profiling of different biological matrices. Additionally, nuclear magnetic resonance (NMR) imaging is also widely used for metabolomics analysis. A major difference between the two tools is that NMR is a non destructive process and samples used for NMR can be reused for other purposes or returned to the biorepository whereas this is not possible with the LCMS method.

Metabolomic studies can be conducted using a "targeted approach" where a few selected analytes (metabolites) are analyzed based on hypothetical research. Such studies are mainly performed in early discovery phases. Alternatively, a more "broad spectrum" approach may be used in order to develop biomarkers for certain treatments or specific disease states.

As with other "omics" approaches, state-of-the art bioinformatics and statistical tools are used for quantitative interpretation of the data generated from metabolomics platforms (LCMS, NMR)."

*Rebecca C. Fry. Systems Biology in Toxicology and Environmental Health, Chapter 4 (Kindle Location 1954). Elsevier Inc.*

## Metabolomics Workflow

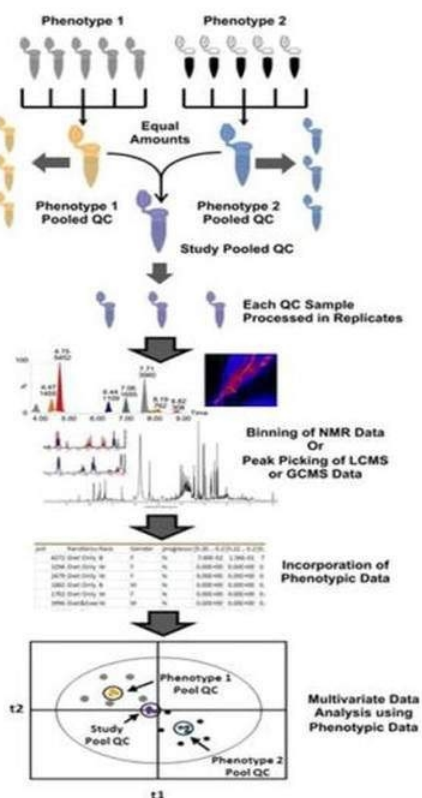

Figure 4.5.7: Metabolomics Workflow. Rebecca C. Fry. Systems Biology in Toxicology and Environmental Health, Chapter 4 (Kindle Location 1954). Elsevier Inc.

### Topic 5: Key Points

In this section, we explored the following main points:

- 1: The application of the different “omics” technologies in systems toxicology.

#### 📌 Knowledge Check

1. Which of the following processes is a non destructive process in which samples can reused or returned back to the biorepository?

- Microarray
- DNA sequencing
- NMR
- Protein Isolation

**Answer**

NMR

2. Which of the following technologies is used to study complete RNA profiles

- Nuclear Magnetic Resonance
- Microarrays
- DNA sequencing
- Physiologically based pharmacokinetic models

**Answer**

## Microarrays

3. The central dogma of molecular biology states is...

DNA to RNA and RNA to protein

RNA to protein to DNA

Protein to DNA to RNA

None of the above

**Answer**

DNA to RNA and RNA to protein

4. Liquid Chromatography mass spectroscopy is used for...

Genomics

Proteomics

Metabolomics

Proteomics and metabolomics

**Answer**

Proteomics and metabolomics

This page titled [4.5: Technologies Used In Systems Biology/Toxicology](#) is shared under a [CC BY-NC 4.0](#) license and was authored, remixed, and/or curated by [ToxMSDT Online component](#) via [source content](#) that was edited to the style and standards of the LibreTexts platform.

## 4.6: Takeaways Summary

---

The tremendous advancement at the technological level has made it possible to generate data at “high-throughput” levels. It has also enabled scientists to study toxicological processes from a more holistic approach. Instead of answering single questions at a time, a more comprehensive approach is now being applied to understand toxicological responses. “Systems” approach is being effectively used in industry, government and clinical settings.

In biopharmaceutical/chemical industries, thousands of molecules are screened in the early discovery phase to select target compounds with efficacy. Similarly, compounds can also be screened based on their toxicity fingerprints. Molecular fingerprints generated for each class of compounds/ specific chemistries can be used to screen compounds for different indications for future uses. This has also significantly reduced the time and increased efficiency in discovery programs in industry settings.

The government has also been using “the systems” approach successfully for safety assessment programs. Efforts such as the ToxCast and Tox 21 are examples where “systems” toxicology is being efficiently used to prioritize animal testing towards chemicals that pose the greatest risk to human health and safety.

In the clinical setting more and more information is becoming available via the “systems” approach for specific disease states that enable physicians and researchers to develop personalized medicines based on specific needs of patients.

While, all these efforts mark the beginning of a very promising future, there is still a lot of research necessary to utilize these tools and technologies to their full potential.

### REFERENCES

- Systems Biology in Toxicology and Environmental Health. First Edition. Editor Rebecca Fry. Chapters 1 and 4
- Incorporating Human Dosimetry and Exposure into High-Throughput In Vitro Toxicity Screening. *Rotroff et al., Toxicological Sciences*; 117(2), 348–358 (2010)

---

This page titled [4.6: Takeaways Summary](#) is shared under a [CC BY-NC 4.0](#) license and was authored, remixed, and/or curated by [ToxMSDT Online component](#) via [source content](#) that was edited to the style and standards of the LibreTexts platform.

## Section 4 Final Evaluation

---

**1. *In vitro* to *in vivo* extrapolation (IVIVE) is modeling software that can utilize *in vitro* data and mathematically translate that into relevant *in vivo* information utilizing pharmacokinetic (PK).**

True

False

**Answer**

True

**2. Which of the following is a common tool used for both Quantitative Structure Activity Relationships (QSAR) and Physiologically based pharmacokinetic (PBPK)?**

GastroPlus

ADMET Predictor

ACD Toxsuite

Derek

**Answer**

GastroPlus

**3. HumanOmni 5 Quad (Omni 5), illumina Omni Arrays and the Affymetrix platforms are common methods used in:**

Transcriptomics

Genomics

Proteomics

Metabolomics

**Answer**

Genomics

**4. Quantitative Structure Activity Relationships (QSAR) approaches for predictive toxicity testing requires all the following EXCEPT:**

Lots of data in order to build robust databases.

Validation of QSAR relationships with large sets of *in vitro* and *in vivo* datasets.

Extensive collaboration between scientists across different disciplines of toxicology.

A mass spectrophotometer.

**Answer**

A mass spectrophotometer.

**5. Computational modeling tools utilizes the *in vitro* data and integrate them into human physiology with the help of...**

Physiologically based pharmacokinetic model.

High-throughput *in vitro* model.

Hypothesis and diagnostic model.

Mathematical and computational model.

**Answer**

Physiologically based pharmacokinetic model.

**6. Systems toxicology aims to fill this gap and utilize these data from different systems and integrate them into meaningful assessment for safety. This gap is:**

Lack of modern equipment and technology for data collection.

Lack of interpretation and utilization of collected data.

Lack of human resources and management.

Lack of organ and system models.

**Answer**

Lack of interpretation and utilization of collected data.

**7. Adverse Output Pathways (AOP) can be assessed in the following stages:**

Molecular initiating event

Intermediate response at cellular level

Toxic response at organic level

All of the above

**Answer**

All of the above

**8. In Metabolomics, the major difference between liquid chromatography mass spectrometers (LCMS) and nuclear magnetic resonance (NMR) is...**

NMR samples cannot be reused for other purposes while LCMS samples can be reused for other purposes.

NMR is a destructive process whereas LCMS is a non-destructive process.

NMR is a non-destructive process whereas LCMS is a destructive process.

NMR samples cannot be returned to the biorepository whereas LCMS samples can be returned to the biorepository.

**Answer**

NMR is a non-destructive process whereas LCMS is a destructive process.

**9. In the study of the underlying mechanisms of different diseases at the genomic level, the most common form of variants at this level is:**

Polyploidy

Aneuploidy

Single Nucleotide Polymorphism (SNP)

Micronuclei variants

**Answer**

Single Nucleotide Polymorphism (SNP)

**10. \_\_\_\_ is used for analysis of proteomics data:**

A mass spectrophotometer

DNA micro array

Illumni Omni Array

DNA sequencing



**Answer**

A mass spectrophotometer

**11. The ToxCast program utilizes which kind of assays?**

In vivo

In vitro

In silico

All of the above

**Answer**

In vitro

**12. The following agencies were established to address the challenge of large number of chemicals that go to market with very limited or no toxicity testing:**

Environmental Protection Agency (EPA) in the US.

Registration Evaluation Authorization and Restriction of Chemicals (REACH) in Europe.

Both A & B are correct.

Occupational Safety and Health Administration (OSHA).

**Answer**

Both A & B are correct.

---

This page titled [Section 4 Final Evaluation](#) is shared under a [CC BY-NC 4.0](#) license and was authored, remixed, and/or curated by [ToxMSDT Online component](#) via [source content](#) that was edited to the style and standards of the LibreTexts platform.

## CHAPTER OVERVIEW

### 5: Regulatory Toxicology

Regulatory toxicology is where the science of toxicology meets the regulations, policies and guidelines that protect human health and the environment from chemicals. In this e-module you will learn about global, regional, national, state, and non-governmental regulatory toxicology.

[5.1: Introduction to Regulatory Toxicology](#)

[5.2: Global Regulatory Toxicology](#)

[5.3: Topic 3: Regional Regulatory Toxicology](#)

[5.4: National Regulatory Toxicology](#)

[5.5: State Regulatory Toxicology](#)

[5.6: Non-Governmental Regulatory Toxicology](#)

[Section 5 Final Evaluation](#)

---

This page titled [5: Regulatory Toxicology](#) is shared under a [CC BY-NC 4.0](#) license and was authored, remixed, and/or curated by [ToxMSDT Online component](#) via [source content](#) that was edited to the style and standards of the LibreTexts platform.

## 5.1: Introduction to Regulatory Toxicology

### Learning Objectives

- 1: Identify regulatory toxicology inside and outside of government.
- 2: Give examples of regulatory toxicology at various scales and locales.
- 3: Explain the difference between regulation and guidance.

### What is Regulatory Toxicology?

Regulatory Toxicology is where the science of toxicology meets the regulations, policies and guidelines that protect human health and the environment from chemicals. Regulatory toxicology commonly is associated with government agencies. These agencies may vary dramatically in their size and scope. For example, the United Nations covers the entire globe, while agencies within a city are limited to the area covered by the municipality.

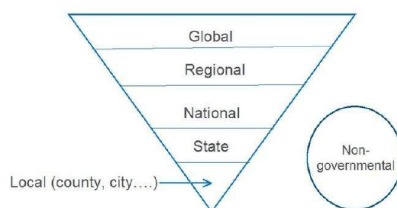

Figure 5.1.1: Introduction to regulatory toxicology

Regulatory agencies generally have specific focus areas that they address. For example, the U.S. Occupational Safety and Health Administration (OSHA) covers hazardous chemicals in the workplace, while the U.S. Consumer Product Safety Commission (CPSC) addresses chemical hazards in consumer products. Lastly, regulatory toxicology also occurs in non-governmental agencies such as professional societies, private industry and various advocacy groups. Further discussion of these is provided later in the module. More information on [OSHA](#) and [CPS](#).

### What is the difference between a regulation, policy, and guideline?

A regulation is a rule or order issued by a governmental authority that has the force of law. Often regulations are developed by experts in a governmental authority to enforce legislation. An example of a regulation is the [Food Quality Protection Act \(FQPA\)](#) passed by the U.S. Congress and signed into law by the President in 1996.

Policies and guidelines are principles and approaches that clarify and interpret regulations. As such, policies and guidelines do not carry the force of law but provide important direction.

The Federal Insecticide, Fungicide and Rodenticide Act (FIFRA) is a U.S. regulation that regulates the broad class of chemicals used as pesticides (i.e., substances used to combat “pests”). The U.S. Environmental Protection Agency (EPA) has authority over FIFRA, and has in turn established many policies and guidelines concerning pesticides.

One area that EPA has established multiple policies and guidelines is in the [registration of pesticides](#) (i.e., EPA review and approval).

#### Topic 1: Key Points

In this section, we explored the following main points:

- 1: What is Regulatory Toxicology?
- 2: What is the difference between a regulation, policy and guidance

### Knowledge Check

1. What is regulatory toxicology?

The forces that govern the regulation of homeostasis in the body

The branch of toxicology that studies regulations

The intersection of the science of toxicology with the regulatory world protecting human health and the environment

Regulations that dictate the science underlying toxicology

**Answer**

The intersection of the science of toxicology with the regulatory world protecting human health and the environment

2. Which of the following have the force of law?

A regulation

A policy

A guideline

All of the above

**Answer**

A regulation

---

This page titled [5.1: Introduction to Regulatory Toxicology](#) is shared under a [CC BY-NC 4.0](#) license and was authored, remixed, and/or curated by [ToxMSDT Online component](#) via [source content](#) that was edited to the style and standards of the LibreTexts platform.

## 5.2: Global Regulatory Toxicology

### Learning Objectives

- 1: Define what is meant by “global regulatory toxicology”
- 2: Give an example of a global regulatory guideline

### What is Global Regulatory Toxicology?

Global regulatory toxicology is exactly as it sounds, it deals with regulatory toxicology on a global scale (i.e., the entire planet). Relative to other jurisdictions (e.g., nations, states, cities), there are few regulatory toxicology initiatives that are global in nature. Some initiatives (e.g., clean drinking water, clean air) with similar intent may span many parts of the globe and appear global, but they lack a global consensus.

Global regulatory toxicology initiatives often originate from activities by the [United Nations \(UN\)](#), a global organization bringing together member countries to confront common challenges.

### Example of Global Regulatory Toxicology: Globally Harmonized System (GHS)

Full name is the Globally Harmonized System of Classification and Labelling of Chemicals (GHS). It was created by the UN. Work on GHS began in 1992 and the first edition was released in 2003. GHS is updated every two years. The goal is to harmonize the criteria by which chemicals are classified in terms of their hazards. Hazards include physical (e.g., flammability), environmental (e.g., toxicity to fish), and human health (e.g., acute toxicity people).



Example of GHS classification – Hazards to the Eye					
Category	Hazard	Hazard statement	Requirement for eye protection?	Signal Word	Symbol
1	Irreversible effects	Causes serious eye damage.	Yes	DANGER!	
2A	Reversible effects	Causes serious eye irritation.	Yes	WARNING!	
2B	Reversible effects	Causes eye irritation.	No	WARNING!	None
Not classified	None	None	No	None	None

Figure 5.2.1: The Globally Harmonized System (GHS)

### The Globally Harmonized System (GHS)

Prior to Globally Harmonized System (GHS), each country had its own criteria for hazard classification, and some countries had multiple criteria. This provided challenges and confusion to the general public and other stakeholders. GHS is a guideline, not a regulation. However, once adopted by a country, GHS generally becomes a regulation.

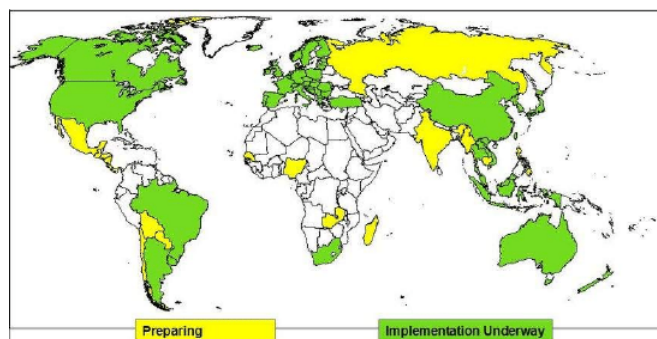

Figure 5.2.2: GHS Implementation Status – May, 2017

### Topic 2: Key Points

In this section, we explored the following main points:

- 1: What is Global Regulatory Toxicology?
- 2: The Globally Harmonized System (GHS)

#### Knowledge Check

1. Which of the following generally is involved with establishing a global regulatory toxicology initiative?

Environmental Protection Agency (EPA)

United Nations (UN)

Food and Drug Administration (FDA)

All of the above

**Answer**

United Nations (UN)

2. Which of the following is an example of a global regulatory toxicology initiative?

Clean Air Act

Clean Water Act

Globally Harmonized System

Safe Drinking Water Act

**Answer**

Globally Harmonized System

This page titled [5.2: Global Regulatory Toxicology](#) is shared under a [CC BY-NC 4.0](#) license and was authored, remixed, and/or curated by [ToxMSDT Online component](#) via [source content](#) that was edited to the style and standards of the LibreTexts platform.

## 5.3: Topic 3: Regional Regulatory Toxicology

### Learning Objectives

- 1: Define what is meant by a “regional regulatory toxicology”
- 2: Give an example of a regional regulation

### What is Regional Regulatory Toxicology?

Regional regulatory toxicology exists between global and national regulatory toxicology. It deals with regulatory toxicology that includes multiple countries. Often these countries are adjacent or in close proximity (e.g., United States and Canada) but that is not a requirement.

A group of nations that frequently exert regulations on a regional scale is [the European Union \(EU\)](#). The EU started in 1951 with six European countries agreeing to cooperate and has expanded over the ensuing decades to the current list of 28 member countries. -One current member of the EU, the United Kingdom has decided through a popular vote to eventually exit the EU (i.e., Brexit).

It started as a paper in 2001 and entered into force on June 1, 2007. It's a new approach for the regulation of chemicals in the EU. Required key hazard information to be obtained for existing chemicals to remain in commerce, or for a new chemicals to enter into commerce.

Information falls into three broad hazard categories: physical-chemical, human health and environmental health. The types and amounts of information varies depending on the volume of chemical used in commerce. The more the chemical is used, the more the data.



In addition to hazard information, [REACH](#) requires assessments to determine if chemicals in commerce pose unreasonable risk(s). REACH has resulted in the assessment and/or re-assessment of 1000s of chemicals. A large [database of toxicity information](#) was created. Some countries are using REACH as a model to develop new, or update existing, chemical regulations, for example, South Korea with [K-REACH](#).

### Topic 3: Key Points

In this section, we explored the following main points:

- 1: What is Regional Regulatory Toxicology?
- 2: The Registration, Evaluation, Authorization and restriction of CHemicals (REACH) regulation

### Knowledge Check

1. Which of the following generally is a trait commonly found in a regional regulatory toxicology initiative?

Involvement of multiple regulatory agencies within a country

Involvement of all/most countries around the globe

Involvement of multiple states within the United States

Involvement of two or more countries in a regulatory initiative

#### Answer

Involvement of two or more countries in a regulatory initiative

2. Which of the following is an example of a regional regulatory toxicology initiative?

GHS

REACH

K-REACH

FQPA

**Answer**

REACH

This page titled [5.3: Topic 3: Regional Regulatory Toxicology](#) is shared under a [CC BY-NC 4.0](#) license and was authored, remixed, and/or curated by [ToxMSDT Online component](#) via [source content](#) that was edited to the style and standards of the LibreTexts platform.



## 5.4: National Regulatory Toxicology

### Learning Objectives

After completing this lesson, you will be able to:

- Define what is meant by “National Regulatory Toxicology”.
- Give an example of a national regulatory regulation.

### What is National Regulatory Toxicology?

As the name suggests, it focuses on regulatory toxicology at the national level (e.g., United States, Canada, China). Regulations are set by authorities that apply for the entire country. The focus on the United States (US) deals with regulations established at the federal level, and all states within the US must comply with federal regulations.

Agency	Population Served	Mainly Regulates Substances in:
EPA	General population (humans); Environment (e.g., aquatic species)	• Environment (e.g., air, soil, water)
FDA	General population; Medical Patients	• Food • Drugs and Medical Devices
OSHA	Workers	• Occupational environment (e.g., air in a factory)
CPSC	Consumers	• Consumer products (e.g., shampoos, toys, clothing)

Figure 5.4.1: Example agencies that set national toxicology regulations in the U.S.

### Example agencies that set national toxicology regulations in the U.S.:

- [Environmental Protection Agency \(EPA\)](#)
- [Food and Drug Administration \(FDA\)](#)
- [Occupational Safety and Health Administration \(OSHA\)](#)
- [Consumer Product Safety Commission \(CPSC\)](#)

All agencies aim to set regulations to protect against adverse health effects from exposure to substances. Different agencies regulate on different types of substances, that are used for different purposes and affect different populations.

Goal of **EPA** is to protect human and environmental health; deals with exposures to substances in the environment (e.g., air, water, soil). It typically pertains to exposures that the general population generally does not have control over (e.g., air pollution) as well as modernizing chemical regulation in the US, e.g. [Toxic Substances Control Act \(TSCA\)](#) was recently revised.

TSCA was first passed in 1976. TSCA was revised with passage of the **Frank R. Lautenberg Chemical Safety for the 21st Century Act** in 2016. It regulates new or already existing chemicals manufactured or in use in the US.

### Topic 4: Key Points

In this section, we explored the following main points:

- 1: What is National Regulatory Toxicology?
- 2: Examples of National Agencies in the U.S.
- 3: What do these Agencies regulate?
- 4: Highlight: EPA and TSCA Reform.

### Knowledge Check

1. EPA regulates chemicals that are in:

Food

Environmental media (e.g., water, air)

Drugs and Medical Devices

Shampoo

**Answer**

Environmental media (e.g., water, air)

2. US States can choose not to comply with regulations set by the FDA

True

False

**Answer**

False

---

This page titled [5.4: National Regulatory Toxicology](#) is shared under a [CC BY-NC 4.0](#) license and was authored, remixed, and/or curated by [ToxMSDT Online component](#) via [source content](#) that was edited to the style and standards of the LibreTexts platform.

## 5.5: State Regulatory Toxicology

### Learning Objectives

- 1: Define what is meant by “State Regulatory Toxicology”.
- 2: Give an example of a state regulatory regulation.

### What is State Regulatory Toxicology?

As the name suggests, it deals with regulatory toxicology for the US on a state level (e.g. Texas, Delaware, Arizona). It was established by authorities applicable to a given state. State regulatory toxicology only applies with the state’s boundaries; however, they may influence adjacent states or even national regulatory toxicology.

State regulatory toxicology is under the layer of the US national government. It sits under a complex web of state and local laws and policies, in addition to regulatory authorities. The make-up of state and local governments varies widely across the US; while they have mutual specific features, their organizations differ. Whatever their design, state and local governments can sometimes have a much greater impact on people's lives than the federal government.

The Federal-State Toxicology and Risk Analysis Committee (FSTRAC) is made up of representatives from U.S. state health and environmental agencies and U.S. EPA personnel.

FSTRAC is an integral part of EPA’s communication strategy with states and tribes for human health risks associated with water contamination. It fosters cooperation, consistency, and an understanding of EPA’s and different states’ goals and problems in human health risk assessment. Additionally, it allows states and the federal government to work together on issues related to the development and implementation of regulations and criteria under the [Safe Drinking Water Act](#) and [Clean Water Act](#).

#### **FSTRAC members have supported development of Human Health Benchmarks for Pesticides (HHBP).**

- 1: Represent levels of pesticides in drinking water that are not anticipated to cause health effects.
- 2: Used to help assess drinking water quality for pesticides that do not have other regulatory toxicology standards.

#### **Examples of agencies that set national toxicology regulations in the U.S.:**

- 
- 
- 
- 
- 
- 

**The goal of state agencies is the same as federal agencies, protect people and the environment from health effects associated with chemical exposures.**

**States have differing regulatory toxicology requirements and focuses. Reasons for the differences could be due to: state history, geography, culture, population size and diversity, major industries, etc...**

Examples of state regulatory toxicology as it concerns chemicals in air:

#### **TEXAS**

Effects Screening Levels (ESLs) – Air concentrations generally applicable to a specific chemical set by the Texas Commission on Environmental Quality (TCEQ). Play an important role in the regulation of air emissions from companies located in the state. List of ESLs [here](#).

#### **CALIFORNIA**

Reference Exposure Levels (RELs) – Air concentrations generally applicable to a specific chemical set by the California Environmental Protection Agency (CalEPA). Represent an air concentration that does not pose a health risk to people. List of RELs [here](#).

Agency	State Specific Rule or Regulation	Requirement
CalEPA	Proposition 65	<ul style="list-style-type: none"> <li>List of chemicals known to the state to cause cancer or reproductive toxicity</li> </ul>
TCEQ	Texas Risk Reduction Program (TRRP)	<ul style="list-style-type: none"> <li>Established cleanup standards for contaminated chemical sites</li> </ul>

Figure 5.5.1: Example of state toxicology regulations and the requirement that must be followed.

### Example agencies that set state toxicology regulations

- 
- 
- 

Agency	Regulation
Office of Environmental Health Hazard Assessment	<a href="#">Proposition 65 (Prop 65)</a>
State of Washington Department of Ecology	<a href="#">Children's Safe Products Act (CSPA)</a>
Minnesota Department of Health – Environmental Health	<a href="#">Minnesota Wellhead Protection Program</a>

Figure 5.5.2: Example agencies that set state toxicology regulations.

An example of a State Regulatory Agency is the **CalEPA Office of Environmental Health Hazard Assessment (OEHHA)**: Provides requirements and guidance for the California Proposition 65 Safe Drinking Water and Toxic Enforcement Act of 1986 (Proposition 65).

## Proposition 65

### Purpose

Enable consumers to make informed decisions regarding chemical exposures.

### Reason

Established to protect California citizens from chemicals known to the state to cause cancer, birth defects, or other reproductive harms.

### Scope

Addresses chemical exposures to the citizens of California that may occur through consumer products, workplace exposures, and exposures occurring via the environment.

### Basics

OEHHA publishes a list of chemicals known to cause cancer, birth defects or other reproductive harm. The list is updated regularly and currently contains approximately 900 chemicals. Once a chemical is listed, companies have 12 months to comply with warning requirements under the regulation.

Proposition 65 is referred to as a “risk-based” regulation in that the warning requirements only apply if the risk from chemical exposure are too high as defined by the regulation.

### **Exposure examples:**

- Oral
- Inhalation
- Skin contact

### Proposition 65 upcoming changes...

The regulation has undergone revisions: [New Proposition 65 Warnings](#), that will now require companies to add a symbol and change the phrasing of the warning. For example: “**WARNING:** This product can expose you to chemicals including arsenic, which is known to the State of California to cause [cancer](#). For more information, visit [here](#).”

## Topic 5: Key Points

In this section, we explored the following main points:

- 1: What is State Regulatory Toxicology?
- 2: An example of how federal and state agencies work together
  - What is the Federal-State Toxicology and Risk Analysis Committee (FSTRAC)
  - Two example outcomes of the FSTRAC's workgroup
- 3: Example of State Agencies
- 4: Highlight two state specific guidance and rules as it concerns chemicals in air
  - Guidance
    - Effects Screening Levels (ESLs)
    - Reference Exposure Levels (RELs)
- 5: Rules
  - California Proposition 65
  - Texas Risk Reduction Program rule

### Knowledge Check

1. Proposition 65 is a regulation established in:

Florida

Texas

California

New York

#### Answer

California

2. Which of the following could explain some of the variability observed between states in terms of regulatory toxicology?

Degree of urbanization

Type of natural resources

Degree of industrialization

All of the above

#### Answer

All of the above

This page titled [5.5: State Regulatory Toxicology](#) is shared under a [CC BY-NC 4.0](#) license and was authored, remixed, and/or curated by [ToxMSDT Online component](#) via [source content](#) that was edited to the style and standards of the LibreTexts platform.

## 5.6: Non-Governmental Regulatory Toxicology

### Learning Objectives

- 1: Define what is meant by a “Non-Governmental Regulatory Toxicology”.
- 2: Give several examples of non-governmental entities that conduct and influence regulatory toxicology.

### What is Non-Governmental Regulatory Toxicology?

They are groups that are not officially part of a government agency that conduct and/or influence regulatory toxicology. Examples of such groups may include not-for-profit organizations, advocacy groups, professional societies, industry trade associations and individual companies. The term “NGO” (short for non-governmental organization(s)) is sometimes used; however, the term “NGO” often is limited to advocacy groups.

These groups often can conduct or influence regulatory toxicology on a much faster timeframe than government agencies. Government agencies often take many months or years to enact regulations, policies, and guidance; while non-governmental entities often proceed at a fraction of this time. Lastly, they often lack the transparency found in government agencies in terms of decision making, as well as the ability to provide input.

### Examples of a non-governmental entities that conduct and influence regulatory toxicology

- 
- Advocacy groups – Often have a particular focus such as the proper treatment of animals, environmental sustainability, women’s health...
- Individual companies – For-profit businesses that decide to address a particular topic related to regulatory toxicology. Examples include eliminating use of certain chemicals, reduce use of water, increasing recycling...
- Trade Associations – represent business that have a common or similar commercial interest (e.g., chemical manufacture, consumer products). Often create industry best practices or guidance for issues related to regulatory toxicology.

### Topic 6: Key Points

In this section, we explored the following main points:

- 1: What is Non-Governmental Regulatory Toxicology?
- 2: Examples of different types of non-governmental entities that conduct and influence regulatory toxicology.

### Knowledge Check

1. Which of the following is a trait found in a non-governmental entities?

Must engage with the general public prior to taking actions.

Have lengthy processes that often take decades to complete.

Is not a government agency or formally associated with a government agency.

A narrowly defined entity that is not common in society.

#### Answer

Is not a government agency or formally associated with a government agency.

2. Which of the following is an example of non-governmental regulatory toxicology?

A not-for profit company developing standards and conducting certifications regarding the sustainability of products.

An advocacy group that provides input to government and industry related to reducing lead in consumer products.

An organization representing chemists develops guidance on workplace safety concerning corrosive chemicals.

All of the above

**Answer**

All of the above

---

This page titled [5.6: Non-Governmental Regulatory Toxicology](#) is shared under a [CC BY-NC 4.0](#) license and was authored, remixed, and/or curated by [ToxMSDT Online component](#) via [source content](#) that was edited to the style and standards of the LibreTexts platform.

## Section 5 Final Evaluation

---

1. \_\_\_\_\_ was created by UN to harmonize the criteria by which chemicals are classified in terms of their hazards.

Federal Insecticide, Fungicide and Rodenticide Act (FIFRA).

Consumer Product Safety Commission (CPSC).

Globally Harmonized System of Classification and Labelling of Chemicals (GHS).

The US Food and Drug Administration (FDA).

**Answer**

Globally Harmonized System of Classification and Labelling of Chemicals (GHS).

2. Regulatory agencies generally have specific focus areas that they address, examples include the following EXCEPT:

Food Quality Protection Act (FQPA) addresses the quality of food and chemicals used in an environment.

Consumer Product Safety Commission (CPSC) addresses chemical hazards in consumer products.

Occupational Safety and Health Administration (OSHA) addresses hazardous chemicals in the work place.

Food and Drug Administration (FDA) regulates pharmaceutical drugs used in humans and animals.

**Answer**

Food Quality Protection Act (FQPA) addresses the quality of food and chemicals used in an environment.

3. Food and Drug Administration (FDA) is a national regulatory agency that serves general population and medical patients while Consumer Product Safety Commission (CPSC) serves general population and environment.

True

False

**Answer**

False

4. The purpose of Proposition 65 is to enable consumers make informed decisions regarding chemical exposures while its scope is to address chemical exposures to citizens of California that may occur through consumer products, workplace and environmental exposures.

True

False

**Answer**

True

5. Registration, Evaluation, Authorization and restriction of CHemicals (REACH) is an example of:

Global regulatory toxicology.

Regional regulatory toxicology.

National regulatory toxicology.

State regulatory toxicology.

**Answer**

Regional regulatory toxicology.

6. One of the advantages of a Non-Governmental Organization (NGO) over government agencies is:



NGOs often conduct regulatory toxicology on a much faster timeframe than government agencies.  
NGOs are transparent in terms of decision making while government agencies are not transparent.  
NGOs are not only limited to advocacy group but it influences global regulations.  
NGOs are officially part of government agency that influence regulatory toxicology.

**Answer**

NGOs often conduct regulatory toxicology on a much faster timeframe than government agencies.

**7. The following are examples of national toxicology regulatory agencies in the U.S. EXCEPT:**

Consumer Product Safety Commission (CPSC).  
Environmental Protection Agency (EPA).  
Texas Commission on Environmental Quality (TCEQ).  
Food and Drug Administration (FDA).

**Answer**

Texas Commission on Environmental Quality (TCEQ).

**8. State of Washington Department of Ecology is an agency that sets state toxicology regulations for:**

Proposition 65.  
Wellhead Protection Program.  
Children's Safe Products Act (CSPA).  
Risk reduction Program.

**Answer**

Children's Safe Products Act (CSPA).

**9. Global regulatory toxicology brings together member countries to confront common challenges on a global scale, an example is:**

United Nations (UN).  
Environmental Protection Agency (EPA).  
Consumer Product Safety Commission (CPSC).  
Occupational Safety and Health Administration (OSHA).

**Answer**

United Nations (UN).

**10. Which of the following statements is true?**

CPSC mainly regulates substance in consumer products e.g. shampoos, clothing etc.  
EPA mainly regulates substance in occupational environment e.g. air in a factory.  
CPSC mainly regulates pharmaceutical drugs and medical devices.  
OSHA mainly regulates toxic substances in consumer products.

**Answer**

CPSC mainly regulates substance in consumer products e.g. shampoos, clothing etc.

**11. Which of the following statements is true?**

Policies are principles that clarify regulation and carry the force of law.

Guidelines are approaches that interpret regulations and carry the force of law.

Regulations are rules issued by governmental authority and carry the force of law.

Regulations are orders issued by government authority and do not carry the force of law.

**Answer**

Regulations are rules issued by governmental authority and carry the force of law.

**12. Key hazard information to be obtained for existing chemicals to remain in commerce or for new chemicals to enter into commerce falls into three broad hazard categories:**

Physical-chemical, animal health and environmental health.

Animal health, human health and environmental health.

Environmental health, physical-chemical and biosafety.

Physical-chemical, human health and environmental health

**Answer**

Physical-chemical, human health and environmental health

---

This page titled [Section 5 Final Evaluation](#) is shared under a [CC BY-NC 4.0](#) license and was authored, remixed, and/or curated by [ToxMSDT Online component](#) via [source content](#) that was edited to the style and standards of the LibreTexts platform.

## SECTION OVERVIEW

### 6: Principles of Toxicology

#### Introduction

ToxTutor is a self-paced tutorial covering key principles of toxicology and was adopted from the National Library of Medicine (NLM) chemical and toxicology databases. While a knowledge of anatomy and physiology is not required for viewing ToxTutor, the [Introduction to the Human Body](#) from the National Cancer Institute provides a good introduction to the topic.

## Topics Covered in this Course

ToxTutor is divided into the following sections:

#### Section 1: Introduction to Toxicology

- 1.1: What is toxicology?
- 1.2: Basic Terminology

#### Section 10: Absorption

- 10.1: Introduction to Absorption
- 10.2: Gastrointestinal Tract
- 10.3: Respiratory Tract
- 10.4: Dermal Route
- 10.5: Other Routes of Exposure

#### Section 11: Distribution

- 11.1: Introduction to Distribution
- 11.2: Influence of Route of Exposure
- 11.3: Disposition Models
- 11.4: Structural Barriers to Distribution
- 11.5: Storage Sites

#### Section 12: Biotransformation

- 12.1: Introduction to Biotransformation
- 12.2: Chemical Reactions
- 12.3: Biotransformation Sites
- 12.4: Modifiers of Biotransformation

#### Section 13: Excretion

- 13.1: Introduction to Secretion
- 13.2: Urinary Excretion
- 13.3: Fecal Excretion

13.4: Exhaled Air

13.5: Other Routes

## Section 14: Cellular Toxicology

14.1: Adaptation

14.2: Cell Damage and Tissue Repair

14.3: Cancer

14.4: Neurotoxicity

## Section 15: Intuitive Toxicology and Risk Communication

15.1: Intuitive Toxicology

15.2: Risk Communication

## Section 16: Environmental Toxicology, Environmental Health, and One Health

16.1: Environmental Toxicology

16.2: Environmental Health

16.3: One Health

## Section 17: Conclusion

## Section 2: Dose and Dose Response

2.1: Dose and It's Impact on Toxicity

2.2: The Dose Response Relationship

2.3: Dose Estimates of Toxic Effects

2.4: Determining the Safety of a Drug

2.5: NOAEL and LOAEL

## Section 3: Toxic Effects

3.1: Types of Toxic Effects

3.2: Factors Affecting Toxicity

3.3: Systemic Toxic Effects

3.4: Organ Specific Toxic Effects

## Section 4: Interactions

4.1: Interactions

## Section 5: Toxicity Testing Methods

5.1: Testing and Assessing Toxicity

5.2: Clinical Investigations and Other Types of Human Data

5.3: Epidemiology Studies

## Section 6: Risk Assessment

6.1: Risk Assessment

6.2: Hazard Identification

6.3: Dose-Response Assessment

6.4: Exposure Assessment

## Section 7: Exposure Standards and Guidelines

7.1: Exposure Standards and Guidelines

7.2: Regulation of Consumer Products and Drug Safety

7.3: Environmental Exposure Standards/Guidelines

7.4: Occupational (Workplace) Exposure Standards/Guidelines/Approaches

## Section 8: Basic Physiology

8.1: Introduction to Basic Physiology

8.2: Homeostasis

8.3: Organs and Organ Systems

8.4: Tissues

8.5: Cells

8.6: Chemicals

## Section 9: Introduction to Toxicokinetics

9.1: What is Toxicokinetics

Each section of ToxTutor contains one or more related content pages. *Next* and *Back* buttons are provided to allow you to navigate through these pages. For more information, see the "Getting Around" section below.

The basic principles of toxicology described in ToxTutor are similar to those taught in university programs and are well described in toxicology literature. A list of the textbooks used as the primary resources for the tutorials is found in the [Bibliography](#).

# Using ToxTutor

## Getting Around

It will take approximately three hours to complete this self-paced tutorial.

There are a variety of ways you can navigate ToxTutor. You can:

- Use the [Glossary](#) button in the upper right corner of each page to access the [glossary](#).
- Click the links in the list above (or any underlined words in any module which are linked) to access sections directly.
- Click the Previous and *Next* links at the bottom of each page to move through the material.
- Use a combination of the above methods to explore the course contents.

## Progress

At the top of each page in ToxTutor are links indicating where the current page falls within the overall ToxTutor program. You can click these links to return to this homepage or to the section that contains the page.

## Links

Throughout the course, you will encounter links. Any link to a resource outside of ToxTutor, will typically open in a new tab or window. All other links are to other areas within ToxTutor. Links are bold and underlined as seen [here](#) and [here](#).

In addition, clicking on some images may open another external website for more information.

## Credits

ToxTutor was adopted from the [U.S National Library of Medicine](#) in 2021. More Information can be seen in the ToxTutor [Bibliography](#).

---

This page titled [6: Principles of Toxicology](#) is shared under a [CC BY-NC 4.0](#) license and was authored, remixed, and/or curated by [ToxMSDT Online component](#) via [source content](#) that was edited to the style and standards of the LibreTexts platform.

## CHAPTER OVERVIEW

### Section 1: Introduction to Toxicology

#### Learning Objectives

After completing this lesson, you will be able to:

- Define toxicology and identify adverse effects.
- Recognize the history of toxicology.
- Explain how dose determines whether a substance is a remedy or a poison.
- Differentiate between toxic agents and toxic substances.

#### In this section...

Topics include:

- [1.1: What is toxicology?](#)
- [1.2: Basic Terminology](#)

#### What We've Covered

In this section, we covered several important concepts:

- Toxicology is the study of adverse effects of chemicals and physical agents on living organisms.
- A xenobiotic is a foreign substance taken into the body.
- A toxic agent is any chemical, physical, or biological agent that can produce an adverse biological effect.
- Toxic substances can be systemic toxicants, which affect the entire body or multiple organs, or organ toxicants, which affect a specific organ or tissues.
- The dose of a substance is the most important determinant of toxicity.

#### Coming Up...

In the next section, we will explore the concept of dose and its importance to toxicology in greater detail.

---

This page titled [Section 1: Introduction to Toxicology](#) is shared under a [CC BY-NC 4.0](#) license and was authored, remixed, and/or curated by [ToxMSDT Online component](#) via [source content](#) that was edited to the style and standards of the LibreTexts platform.

## 1.1: What is toxicology?

### What is Toxicology?

Toxicology is traditionally defined as "the science of poisons." Over time, our understanding of how various agents can cause harm to humans and other organisms has increased, resulting in a more descriptive definition of toxicology as "the *study of the adverse effects of chemical, physical, or biological agents on living organisms and the ecosystem, including the prevention and amelioration of such adverse effects.*"



Figure 1.1.1: Photos of a Gila monster and Bothrops jararaca snake. (CC BY-SA 4.0; [Leandro Avelar](#) via [source](#))

These adverse effects can take many forms, ranging from immediate death to subtle changes not appreciated until months or years later. They may occur at various levels within the body, such as an organ, a type of cell, or a specific biochemical. Our understanding of how toxic agents damage the body has progressed along with medical knowledge. We now know that various observable changes in anatomic or bodily functions actually result from previously unrecognized changes in specific biochemicals in the body.

#### Did you know?

The study of toxicology may appear to focus only on poisonings or disasters, but some toxic chemicals can have positive effects. Animal venoms, whether from bees, wasps, snakes, or Gila monsters, are composed of hundreds of chemicals that are being studied as treatments for human diseases.

For example, exantide, a drug derived from Gila monster saliva, has been approved for use in Type 2 diabetes. Captopril, which is used to treat hypertension and heart failure, was developed from studies on the chemical bradykinin-potentiating factor (BPF) in the venom of a South American snake *Bothrops jararaca*. Melittin, which comes from honeybee venom, is being investigated for its anticancer and antifungal properties.

Figure 1.1.1: Figure 1. Gila monster (top); *Bothrops jararaca* (bottom)

(Image Source: Wikipedia, adapted under GNU Free Documentation License - [Original Images](#))

### History of Toxicology

#### Prehistory

Poisonous plants and animals were recognized and their extracts used for hunting or in warfare.

#### 1500 BC

Written records indicate that hemlock, opium, arrow poisons, and certain metals were used to poison enemies or for state executions.

#### c. 1198

With time, people began to make the connection between exposure to a specific substance and illness or death.

In 1198, Moses Maimonides wrote what may be the first collection of writings on toxicology, *The Treatise on Poisons and Their Antidotes*.



## Renaissance and Age of Enlightenment

Certain fundamental toxicology concepts began to take shape. Noteworthy studies include those by Paracelsus in the 16<sup>th</sup> century and Orfila in the 19<sup>th</sup> century.

### Paracelsus (16<sup>th</sup> Century)

Determined that specific chemicals were actually responsible for the toxicity of a plant or animal poison.

Documented that the body's response to those chemicals depended on the dose received.

Studies revealed that small doses of a substance might be harmless or beneficial, whereas larger doses could be toxic. This is now known as the **dose-response relationship**, a major concept in toxicology.

*"All substances are poisons; there is none which is not a poison. The right dose differentiates a poison and a remedy."*

- Paracelsus

### Orfila, the founder of toxicology (19<sup>th</sup> Century)

A Spanish physician, Orfila is often referred to as the **founder of toxicology**.

Orfila was the first to describe a systematic correlation between the chemical and biological properties of poisons of the time.

Orfila demonstrated the effects of poisons on specific organs by analyzing autopsy materials for poisons and tissue damage associated with them.

### 20<sup>th</sup> and 21<sup>st</sup> Centuries

Marked by great advancements in the level of understanding of toxicology.

DNA and various biochemicals that maintain body functions have been discovered.

Our level of knowledge of toxic effects on organs and cells has expanded to the molecular level.

Virtually all toxic effects are recognized as being caused by changes in specific cellular molecules and biochemicals.

## Remedy or Poison?

**Xenobiotic** is the general term that is used for a *foreign* substance taken into the body. It is derived from the Greek term *xeno* which means "foreigner." Xenobiotics may produce beneficial effects (such as pharmaceuticals) or they may be toxic (such as lead).

As Paracelsus proposed centuries ago, dose differentiates whether a substance will be a remedy or a poison. A xenobiotic in small amounts may be nontoxic and even beneficial, but when the dose is increased, toxic and lethal effects may result.

The following image provides some examples that illustrate this concept.

Alcohol is non-toxic at 0.05%, toxic at 0.1%, and lethal at 0.5% ethanol blood levels. Carbon monoxide is non-toxic at less than 10%, toxic at 20 to 30%, and lethal at 60% or more % hemoglobin bound. Secobarbital, a sleep aid, is non-toxic or beneficial at 0.1 mg/dL, toxic at 0.7 mg/dL, and lethal at over 1 mg/dL blood levels. Aspirin is non-toxic or beneficial at 0.65 g (2 tablets), toxic at 9.75 g (30 tablets), and lethal at 34 g (105 tablets). Ibuprofen is non-toxic or beneficial at 400 mg (2 tablets), toxic at 1,400 mg (7 tablets), and lethal at 12,000 mg (60 tablets).

Figure 1.1.2: Figure 3. Examples of varying doses of the same substance as non-toxic or beneficial, toxic, and lethal  
(Image Source: Adapted from T. Gossel and J. Bricker, eds)

This page titled [1.1: What is toxicology?](#) is shared under a [CC BY-NC 4.0](#) license and was authored, remixed, and/or curated by [ToxMSDT Online component](#) via [source content](#) that was edited to the style and standards of the LibreTexts platform.

## 1.2: Basic Terminology

### Toxicology Defined

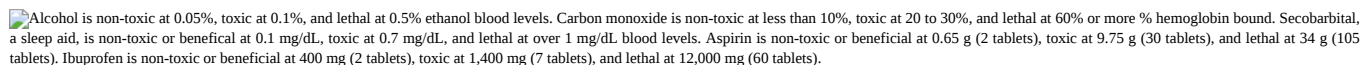
Toxicology is an evolving medical science and toxicology terminology is evolving with it. Most terms are very specific and will be defined as they appear in the tutorial. However, some terms are more general and used throughout the various sections. The most commonly used terms are introduced in this section.

- **Toxicology** is the study of the adverse effects of chemicals or physical agents on living organisms.
- A **toxicologist** is a scientist who determines the harmful effects of agents and the cellular, biochemical, and molecular mechanisms responsible for the effects.
- **Toxinology**, a specialized area of study, looks at microbial, plant and animal venoms, poisons, and toxins.

Terminology and definitions for materials that cause toxic effects are not always consistently used in the literature. The most common terms are toxicant, toxin, poison, toxic agent, toxic substance, and toxic chemical.

Toxicant, toxin, and poison are often used interchangeably in the literature but there are subtle differences as shown below:

#### Toxicants:

- Substances producing adverse biological effects of any kind.
- May be chemical or physical in nature.
- Effects may be acute or chronic.

Person spraying a chemical onto a field of grass

Figure 1.2.1: *Pesticide chemicals are toxicants*  
(Image Source: iStock Photos, ©)

#### Toxins:

- Peptides or proteins produced by living organisms.
- Venoms are toxins injected by a bite or sting.

Mushrooms

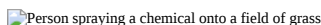
Figure 1.2.2: Amanita muscaria mushroom contains a *neurotoxin*  
(Image Source: iStock Photos, ©)

#### Poisons:

- Toxins produced by organisms.

Black widow spider with a distinctive red hourglass shape on its abdomen

Figure 1.2.3: Black Widow spiders produce a *poison that is a toxin*  
(Image Source: Texas Parks & Wildlife, ©)

A **toxic agent** is anything that can produce an adverse biological effect. It may be chemical, physical, or biological in form. For example, toxic agents may be:

**Chemical (such as cyanide)**

**Physical (such as radiation)**

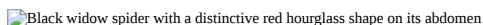
**Biological (such as snake venom)**

The toxicity of the agent is dependent on the dose.

A distinction is made for diseases people get from *living* organisms. Organisms that invade and multiply within another organism and produce their effects by biological activity are not classified as toxic agents but as **biological agents**. An example of this is a virus that damages cell membranes resulting in cell death.

If the invading organisms excrete chemicals which are the basis for their toxicity, the excreted substances are known as **biological toxins**. In that case, the organisms are called **toxic organisms**. A specific example is tetanus. Tetanus is caused by a bacterium,

*Clostridium tetani*. The bacteria *C. tetani* itself does not cause disease by invading and destroying cells. Rather, a toxin (neurotoxin) that the bacteria excrete travels to the nervous system and produces the disease (Figure 8).

## Toxic Substances

A **toxic substance** is simply a material that has toxic properties. It may be a discrete toxic chemical or a mixture of toxic chemicals. For example, lead chromate, asbestos, and gasoline are all toxic substances. More specifically:

- Lead chromate is a discrete **toxic chemical**.
- Asbestos is a **toxic material** that does not have an exact chemical composition but comprises a variety of fibers and minerals.
- Gasoline is a **toxic substance** rather than a toxic chemical in that it contains a mixture of many chemicals. Toxic substances may not always have a constant composition. The composition of gasoline varies with octane level, manufacturer, time of season, and other factors.

Lead chromate, asbestos, and gasoline

Figure 1.2.4 Examples of *toxic substances*: lead chromate (left), asbestos (center), and gasoline (right)  
(Image Source: iStock Photos, ©)

## Systemic Toxicants and Organ Toxicants

Toxic substances may be **systemic toxicants** or **organ toxicants**.

A **systemic toxicant** affects the entire body or many organs rather than a specific site. For example, potassium cyanide is a systemic toxicant in that it affects virtually every cell and organ in the body by interfering with the cells' ability to use oxygen.

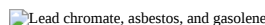
Toxicants may also affect only specific tissues or organs while not producing damage to the body as a whole. These specific sites are known as the **target organs** or **target tissues**.

- Benzene is a **specific organ toxicant** in that it is primarily toxic to the blood-forming tissues.
- Lead is also a specific organ toxicant; however, it has three **target organs**: the central nervous system, the kidneys, and the hematopoietic system.

A toxicant may affect a specific type of tissue (such as connective tissue) that is present in several organs. The toxic site is then considered the **target tissue**.

A systemic toxicant affects the entire body or several organs (left); an organ toxicant affects a specific organ (right)

Figure 1.2.5: Systemic toxicant *and organ toxicant*  
(Image Source: iStock Photos, ©)

## Types of Cells

The body is composed of many types of cells, which can be classified in several ways. Table 1 shows examples of one classification of one type of cells.

Cell Types	Examples
Basic structure	cuboidal cells
Tissue type	hepatocytes of the liver
Germ cells	ova and sperm
Somatic cells	non-reproductive cells of the body

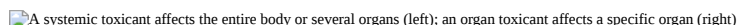
**Germ cells** are involved in reproduction and can give rise to a new organism. They have only a single set of chromosomes peculiar to a specific sex. Male germ cells give rise to sperm and female germ cells develop into ova. Toxicity to germ cells can cause effects in a developing fetus that lead to outcomes such as birth defects or miscarriage.

**Somatic cells** are all body cells except the reproductive germ cells. (Somatic cells include the "basic structure" and "tissue type"

cells listed in Table 1). They have two sets (or pairs) of chromosomes. In an exposed individual, toxicity to somatic cells causes a variety of toxic effects, such as dermatitis, death, and cancer.

Figure 6 illustrates the differences between germ cells and somatic cells.

 Germ cells (sperm and egg cells) have a single set of chromosomes. Somatic cells (all other body cells) have two sets, or pairs, of chromosomes.

Figure 1.2.6: Germ cells and somatic cells (Image Source: National Human Genome Research Institute, <http://www.genome.gov>)

## Natural and Man-Made Chemicals

Often, people mistakenly assume that all man-made chemicals are harmful and natural chemicals are beneficial. In reality, natural chemicals can be just as harmful to human health as man-made chemicals, and in many cases, more harmful. Figure 12 compares the toxicity of several natural and man-made chemicals.

 Infographic titled 'Natural and Man-made chemicals.' A common misconception is that all man-made chemicals are harmful and all natural chemicals are good for us. However, many natural chemicals are just as harmful to human health, if not more so, than man-made chemicals. Examples of chemicals that result in toxic effects at 1000 mg/kg of body weight include natural chemicals such as muscimol (found in fly agaric mushrooms), solanine (found in green potatoes), and amygdalin (found in apple seeds), and man-made chemicals such as ethylene glycol (used in anti-freeze), aspirin, and sodium thiopental (formerly used for lethal injections). Examples of chemicals with no toxic effects seen at 1000 mg/kg of body weight include natural chemicals such as citric acid (found in lemons and limes), sucrose (table sugar), and water; and man-made chemicals such as MSG (a food additive), teflon (used in non-stick pans), and aspartame (an artificial sweetener). Any substance, if given in large enough amounts, can cause death. Some are lethal after only a few nanograms, whilst others require kilograms to achieve a lethal dose. Chemical toxicity is a sliding scale, not black and white - and whether a chemical is naturally occurring or man-made tells us nothing about its toxicity.

Figure 1.2.7: Natural and man-made chemicals (Image Source: <http://pbs.twimg.com/media/CTn6HIDWwAEB1Jc.png:large>, Creative Commons license)

---

This page titled [1.2: Basic Terminology](#) is shared under a [CC BY-NC 4.0](#) license and was authored, remixed, and/or curated by [ToxMSDT Online component](#) via [source content](#) that was edited to the style and standards of the LibreTexts platform.

## CHAPTER OVERVIEW

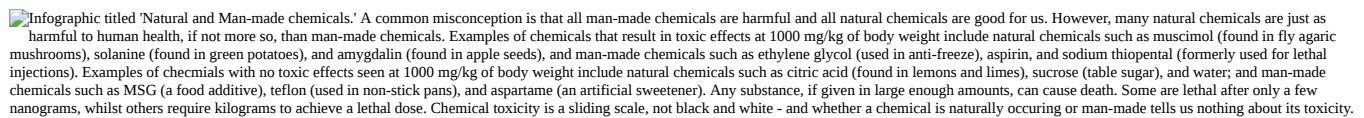
### Section 10: Absorption

## Learning Objectives

After completing this lesson, you will be able to:

- Explain absorption and its role in toxicokinetics.
- Describe the primary routes of exposure.
- Explain the role of cell membranes in absorption.
- Identify ways in which xenobiotics pass across cell membranes.

## In this section...

Topics include:

- [10.1: Introduction to Absorption](#)
- [10.2: Gastrointestinal Tract](#)
- [10.3: Respiratory Tract](#)
- [10.4: Dermal Route](#)
- [10.5: Other Routes of Exposure](#)

## Section 10: Key Points

## What We've Covered

This section made the following main points:

- Absorption is the process by which toxicants gain entrance into the body.
- Ingested and inhaled materials are considered outside the body until they cross the cellular barriers of the gastrointestinal tract or respiratory system.
- The likelihood of absorption depends on the:
  - Route of exposure.
  - Concentration of the substance at the site of contact.
  - Chemical and physical properties of the substance.
- Exposure routes include:
  - Primary routes:
    - Gastrointestinal (GI) tract
      - Mouth and esophagus — poorly absorbed under normal conditions due to short exposure time (nicotine and nitroglycerin are notable exceptions).
      - Stomach — significant site for absorption of weak organic acids, but weak bases are poorly absorbed.
      - Intestine — greatest absorption of both weak bases and weak acids, particularly in the small intestine.
      - Colon and rectum — very little absorption, unless administered via suppository.
    - Respiratory tract
      - Mucociliary escalator — movements of the cilia push mucus and anything contained within up and out into the throat to be swallowed or removed through the mouth.

- Pulmonary region — most important site for absorption with about 50 times the surface area of the skin and very thin membranes.
- Skin
  - Epidermis and stratum corneum — the only layer important in regulating the penetration of a skin contaminant.
  - Toxicants move across the stratum corneum by passive diffusion.
  - If a toxicant penetrates through the stratum corneum, it enters lower layers of the epidermis, dermis, and subcutaneous tissue, which are far less resistant to further diffusion.
- Other exposure routes:
  - Injections
  - Implants
  - Conjunctival instillations (eye drops)
  - Suppositories
- Cell membranes surround all body cells and are made up of a phospholipid bilayer in which each molecule contains a:
  - Polar (hydrophilic, or attracted to water) phosphate head
  - Lipophilic (attracted to lipid-soluble substances) lipid tail
- Xenobiotics must pass across cell membranes to enter, move within, and leave the body. This movement can be either:
  - Passive transfer (most common) — simple diffusion or osmotic filtration with no cellular energy or assistance required.
  - Facilitated transport — similar to passive transport, but a carrier-mediated transport mechanism and thus faster and capable of moving larger molecules.
  - Active transport — movement against the concentration gradient (from lower to higher concentrations), requiring cellular energy from ATP.
  - Endocytosis — the cell surrounds the substance with a section of its cell wall, separating from the membrane and moving into the interior of the cell.

---

This page titled [Section 10: Absorption](#) is shared under a [CC BY-NC 4.0](#) license and was authored, remixed, and/or curated by [ToxMSDT Online component](#) via [source content](#) that was edited to the style and standards of the LibreTexts platform.

## Introduction to Absorption

Toxicants gain entrance into the body by absorption. The body considers ingested and inhaled materials as being outside of it until those materials cross the cellular barriers of the gastrointestinal tract or respiratory system. A substance must be absorbed to exert an effect on internal organs, although local toxicity, such as irritation, may occur.

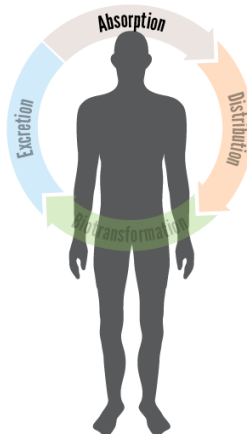

Figure 10.1.1. Processes of toxicokinetics  
(Image Source: Adapted from iStock Photos, ©)

### Absorption Variability

Absorption varies greatly by specific chemicals and the route of exposure.

- For skin, oral or respiratory exposure, the absorbed dose is only a fraction of the exposure dose (external dose).
- For substances injected or implanted directly into the body, exposure dose is the *same* as the absorbed or internal dose.

Several factors affect the likelihood that a xenobiotic will be absorbed. The most important factors are the:

- Route of exposure.
- Concentration of the substance at the site of contact.
- Chemical and physical properties of the substance.

The route of exposure influences how the concentration and properties of the substance vary. In some cases, a high percentage of a substance may not be absorbed from one route whereas a low amount may be absorbed via another route.

- For example, very little [DDT powder](#) will penetrate the skin whereas a high percentage will be absorbed when it is swallowed.

Due to such route-specific differences in absorption, xenobiotics are often ranked for hazard in accordance with the route of exposure. A substance may be categorized as relatively non-toxic by one route and highly toxic via another route.

### Routes of Exposure

The **primary routes of exposure** by which xenobiotics can gain entry into the body are:

- **Gastrointestinal (GI) tract** — important for environmental exposure to contaminants from food and water; the main route for many pharmaceuticals.
- **Respiratory tract** — important for environmental and occupational exposure to air contaminants; some pharmaceuticals (such as nasal or oral aerosol inhalers) use this route.
- **Skin** — important environmental and occupational exposure route; many consumer and pharmaceutical products are applied directly to the skin.

**Other routes of exposure** – used primarily for specific medical purposes:

- **Injections** — primarily used for pharmaceuticals.
- **Implants** — pharmaceuticals may be implanted to permit slow, time-release (for example, hormones). Many medical devices are implanted for which minimal absorption is desired (such as artificial lens or tendons). Some materials enter the body via skin penetration as the result of accidents or weapons.
- **Conjunctival instillations (eye drops)** — primarily for treating ocular conditions; however, in some cases, considerable absorption can occur and cause systemic toxicity.
- **Suppositories** — used for medicines that may not be adequately absorbed after oral administration or that are intended for local therapy; usual locations for suppositories are the rectum and vagina.

### Cell Membranes

**Cell membranes** (often referred to as plasma membranes) surround all body cells and are similar in structure. They consist of two layers of phospholipid molecules arranged like a sandwich, referred to as a "phospholipid bilayer." Each phospholipid molecule consists of a phosphate head and a lipid tail. The phosphate head is polar, meaning it is hydrophilic (*attracted to water*). In contrast, the lipid tail is lipophilic (*attracted to lipid-soluble substances*).

The two phospholipid layers are oriented on opposing sides of the membrane so that they are approximate mirror images of each other. The polar heads face outward and the lipid tails face inward in the membrane sandwich (Figure 10.1.2).

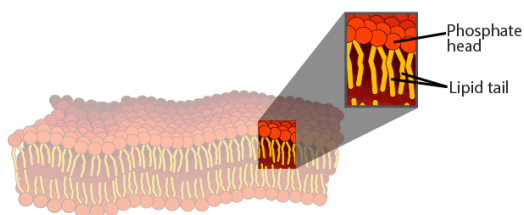

Figure 10.1.2 Each phospholipid molecule consists of a phosphate head and lipid tail (Image Source: Adapted from Wikimedia Commons, obtained under Public Domain, [original image](#))

The cell membrane is tightly packed with these phospholipid molecules interspersed with various proteins and cholesterol molecules. Some proteins span across the entire membrane which can create openings for aqueous channels or pores.

A typical cell membrane structure is illustrated in Figure 10.1.3

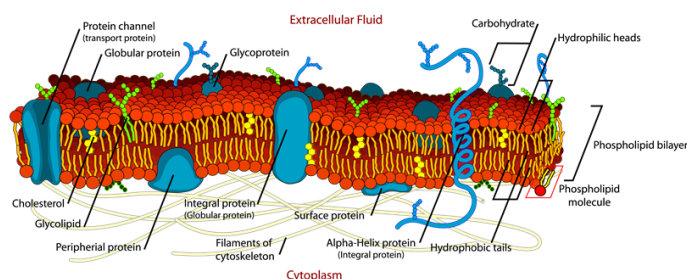

Figure 10.1.3. Typical cell membrane structure (Image Source: Adapted from Wikimedia Commons, obtained under Public Domain, [original image](#))

## Role of Cell Membranes in Absorption

For a xenobiotic to enter the body (as well as move within, and leave the body) it must pass across cell membranes (cell walls). Cell membranes are formidable barriers and a major body defense that prevents foreign invaders or substances from gaining entry into body tissues. Normally, cells in solid tissues (such as skin, or mucous membranes of the lung or intestine) are so tightly compacted that substances cannot pass between them. This requires that the xenobiotic have the ability to penetrate cell membranes. It must cross several membranes to go from one area of the body to another.

For a substance to move through one cell requires that it first move across the cell membrane into the cell, pass across the cell, and then cross the cell membrane again to leave the cell. This is true whether the cells are in the skin, the lining of a blood vessel, or an internal organ such as the liver. In many cases, in order for a substance to reach the site where it exerts toxic effects, it must pass through several membrane barriers.

Animation 1 depicts how a chemical from a theoretical consumer product called a "Shower Gel" might get to the surface of the skin during showering and then pass through several membranes before coming in contact with the inside of a liver cell

[http://www.toxmsdt.com/uploads/b/886...a\\_cell\\_446.mp4](http://www.toxmsdt.com/uploads/b/886...a_cell_446.mp4)

Animation 10.1.1. From a Gel to a Cell: Following the journey of a chemical from a theoretical shower gel product through several membranes and ultimately into a cell (Image Source: iStock Photos, ©)

## Movement of Toxicants Across Cell Membranes

Some toxicants move across a membrane barrier with relative ease while others find it difficult or impossible. Those that can cross the membrane use one of two general methods: 1) **passive transfer** or 2) **facilitated transport**.

Passive transfer consists of **simple diffusion** (or osmotic filtration) and is "passive" because no cellular energy or assistance is required.

Some toxicants cannot simply diffuse across the membrane but require assistance by specialized transport mechanisms. The primary types of specialized transport mechanisms are:

- Facilitated diffusion
- Active transport
- Endocytosis (phagocytosis and pinocytosis)

## Passive Transfer

Passive transfer is the most common way that xenobiotics cross cell membranes. Two factors determine the rate of passive transfer:

1. The difference in concentrations of the substance on opposite sides of the membrane (this occurs when a substance moves from a region of high concentration to one having a lower concentration. Diffusion will continue until the concentration is equal on both sides of the membrane).
2. The ability of the substance to move either through the small pores in the membrane or the lipophilic interior of the membrane.

Properties affecting a chemical substance's ability for passive transfer are:

- Lipid solubility
- Molecular size
- The degree of ionization



Substances with high lipid solubility readily diffuse through the phospholipid membrane. Small water-soluble molecules can pass across a membrane through the aqueous pores, along with normal intracellular water flow.

Large water-soluble molecules usually cannot make it through the small pores, although some may diffuse through the lipid portion of the membrane, but at a slow rate.

- Most aqueous pores are about 4 Angstrom (Å) in size and allow chemicals of molecular weight 100-200 to pass through. Exceptions are membranes of capillaries and kidney glomeruli which have relatively large pores (about 40 Angstrom [Å]) that allow molecules up to a molecular weight of about 50,000 (molecules slightly smaller than albumin which has a molecular weight of 60,000) to pass through.

In general, highly ionized chemicals have low lipid solubility and pass with difficulty through the lipid membrane.

Figure 4 demonstrates the passive diffusion and filtration of xenobiotics through a typical cell membrane.

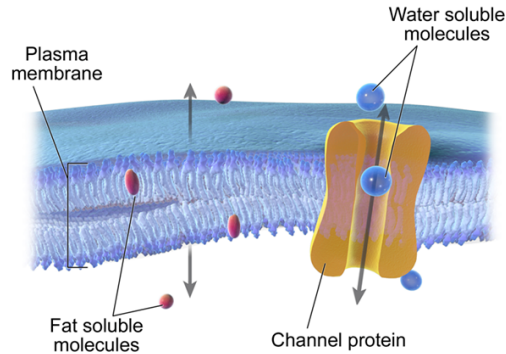

Figure 10.1.4 Cellular diffusion

(Image Source: Blausen.com staff (2014). "[Medical gallery of Blausen Medical 2014](#)". WikiJournal of Medicine 1 (2). DOI:[10.15347/wjm/2014.010](#). ISSN [2002-4436](#). Obtained under Creative Commons license.)

## Facilitated Diffusion

Facilitated diffusion is similar to simple diffusion in that it does not require energy and follows a concentration gradient. The difference is that it is a carrier-mediated transport mechanism (Figure 10.1.5)—that is, special transport proteins, which are embedded within the cell membrane, facilitate movement of molecules across the membrane. The results are similar to passive transport but faster and capable of moving larger molecules that have difficulty diffusing through the membrane without a carrier.

- Examples are the transport of sugar and amino acids into RBCs and the CNS.

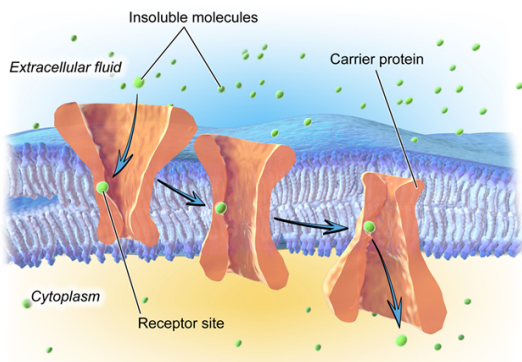

Figure 10.1.5 Facilitated Diffusion

(Image Source: Blausen.com staff (2014). "[Medical gallery of Blausen Medical 2014](#)". WikiJournal of Medicine 1 (2). DOI:[10.15347/wjm/2014.010](#). ISSN [2002-4436](#). Obtained under Creative Commons license.)

## Active Transport

Some substances are unable to move with diffusion, unable to dissolve in the lipid layer, and are too large to pass through the aqueous channels. For some of these substances, **active transport** processes exist in which movement through the membrane may be *against* the concentration gradient, that is, from low to higher concentrations. Cellular energy from adenosine triphosphate (ATP) is required in order to accomplish this. The transported substance can move from one side of the membrane to the other side by this energy process. Active transport is important in the transport of xenobiotics into the liver, kidney, and central nervous system and for maintenance of electrolyte and nutrient balance.

Figure 10.1.6 shows sodium and potassium moving against concentration gradient with the help of the ATP sodium-potassium exchange pump.

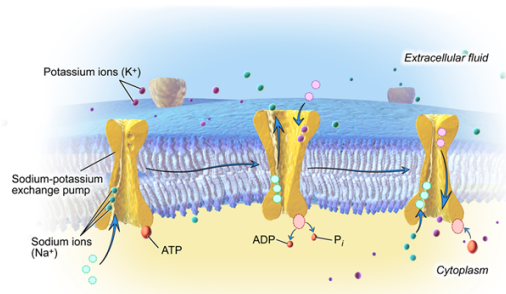

Figure 10.1.6 Sodium-Potassium Exchange Pump

(Image Source: Blausen.com staff (2014). "[Medical gallery of Blausen Medical 2014](#)". WikiJournal of Medicine 1 (2). DOI:[10.15347/wjm/2014.010](#). ISSN [2002-4436](#). Obtained under Creative Commons license.)

## Endocytosis (Phagocytosis and Pinocytosis)

Many large molecules and particles cannot enter cells via passive or active mechanisms. However, some may still enter by a process known as **endocytosis**.

In endocytosis, the cell surrounds the substance with a section of its cell wall. This engulfed substance and section of membrane then separates from the membrane and moves into the interior of the cell. The two main forms of endocytosis are 1) phagocytosis and 2) pinocytosis.

In **phagocytosis** (cell eating), large particles suspended in the extracellular fluid are engulfed and either transported into cells or are destroyed within the cell. This is a very important process for lung phagocytes and certain liver and spleen cells.

**Pinocytosis** (cell drinking) is a similar process but involves the engulfing of liquids or very small particles that are in suspension in the extracellular fluid.

Figure 10.1.7 demonstrates the types of membrane transport by endocytosis.

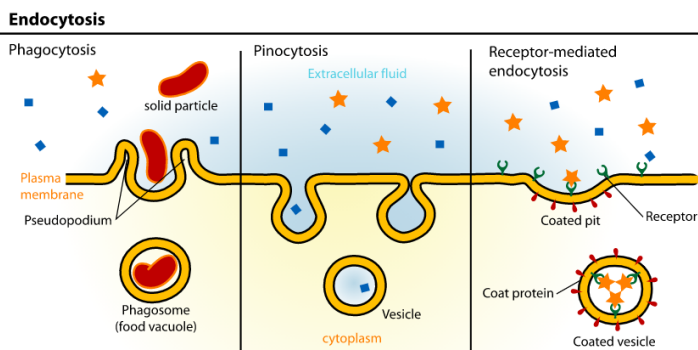

Figure 10.1.7. Types of Endocytosis

(Image Source: Wikimedia Commons, obtained by Public Domain License, [original image](#))

### Knowledge Check

1) The process whereby a substance moves from outside the body into the body is known as:

- Distribution
- Biotransformation
- Absorption

#### Answer

Absorption - **This is the correct answer.**

Absorption is the first and crucial step in the toxicokinetics of a xenobiotic. Without absorption, a toxic substance does not represent a human health hazard.

2) For a xenobiotic to move from outside the body to a site of toxic action requires that it:

- Possess hydrophilic (water-soluble) properties
- Possess hydrophobic (lipophilic) properties
- Pass through several cell membranes

#### Answer

Pass through several cell membranes - **This is the correct answer.**

In order for a xenobiotic to move from outside the body to an internal site of toxic action (target cells), a xenobiotic must pass through several membrane barriers. The first membranes are those at the portal of entry, for example, lung or intestinal tract.

3) The basic structure of the cell membrane consists of:

- A thick protein layer containing phospholipid channels
- A bilayer of phospholipids with scattered proteins within the layers
- Cholesterol outer layer with a phospholipid inner layer

#### Answer

A bilayer of phospholipids with scattered proteins within the layers - **This is the correct answer.**

The typical cell membrane consists of two layers of phospholipids with polar head groups consisting of phospholipid molecules and the lipid inner portion consisting primarily of cholesterol molecules. The phospholipid layers are oriented on opposing sides of the membrane so that they are approximate mirror images of each other. Various proteins are scattered throughout the lipid bilayers of the membrane.

4) The membrane transport process by which large hydrophobic molecules cross membranes via the lipid portion of the membrane, follow the concentration gradient, and do not require energy or carrier molecules is known as:

- a) Simple diffusion
- b) Active transport
- c) Facilitated diffusion

**Answer**

Simple diffusion - **This is the correct answer.**

Large hydrophobic molecules must diffuse through the lipid portion of the membrane, with the rate of transport correlating with its lipid solubility. In general, highly ionized chemicals have low lipid solubility and do not readily pass through the lipid membrane.

5) Endocytosis is a form of specialized membrane transport in which the cell surrounds the substance with a section of its cell membrane. The specific endocytosis process by which liquids or very small particles are engulfed and transported across the membrane is known as:

- a) Phagocytosis
- b) Pinocytosis
- c) Exocytosis

**Answer**

Pinocytosis - **This is the correct answer.**

Pinocytosis (cell drinking) involves the engulfing of liquids or very small particles that are in suspension within the extracellular fluid.

This page titled [10.1: Introduction to Absorption](#) is shared under a [CC BY-NC 4.0](#) license and was authored, remixed, and/or curated by [ToxMSDT Online component](#) via [source content](#) that was edited to the style and standards of the LibreTexts platform.

## 10.2: Gastrointestinal Tract

# Gastrointestinal Tract

The gastrointestinal (GI) tract can be viewed as a tube going through the body (Figure 10.2.1). Its contents are considered exterior to the body until absorbed. Salivary glands, liver, and the pancreas are considered accessory glands of the GI tract as they have ducts entering the GI tract and secrete enzymes and other substances. For foreign substances to enter the body, they must pass through the gastrointestinal mucosa, crossing several membranes before entering the bloodstream.

Substances must be absorbed from the gastrointestinal tract in order to exert a toxic effect throughout the whole body, although local gastrointestinal damage may occur from direct exposures to toxicants. Absorption can occur at any place along the entire gastrointestinal tract. However, the degree of absorption depends on the site.

Three main factors affect absorption within the various sites of the gastrointestinal tract:

1. Type of cells at the specific site.
2. Period of time that the substance remains at the site.
3. pH of stomach or intestinal contents at the site.

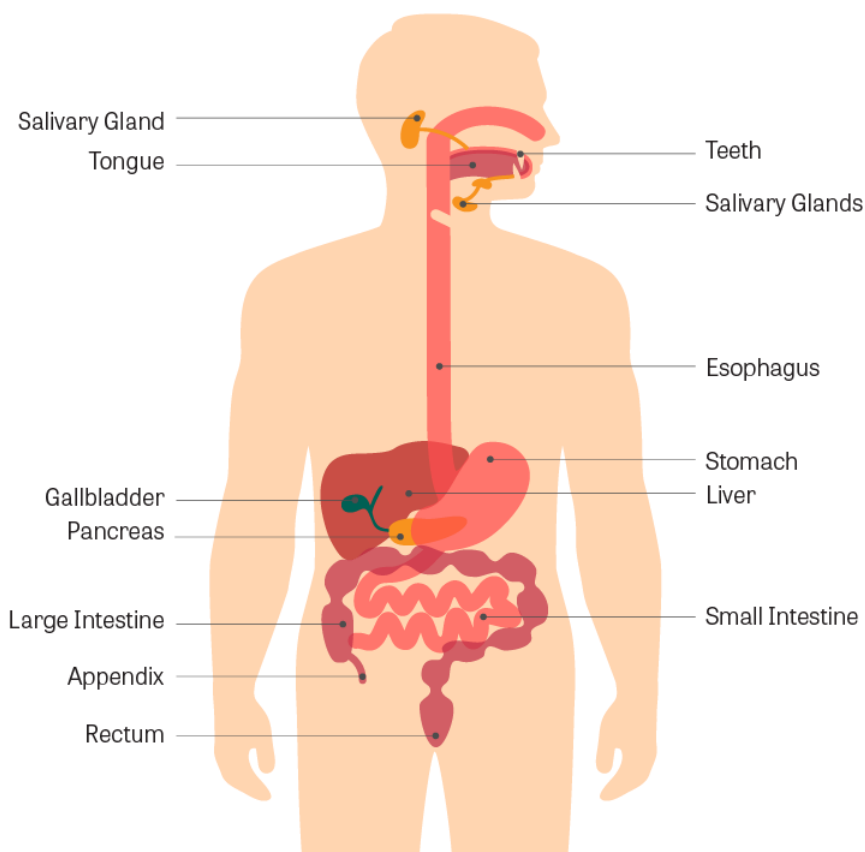

Figure 10.2.1 Anatomy of gastrointestinal tract  
(Image Source: adapted from iStock Photos, ©)

## Mouth and Esophagus

Under normal conditions, xenobiotics are poorly absorbed within the **mouth** and **esophagus**, due mainly to the very short time that a substance resides within these portions of the gastrointestinal tract. There are some notable exceptions. For example:

- Nicotine readily penetrates the mouth mucosa.
- Nitroglycerin is placed under the tongue (sublingual) for immediate absorption and treatment of heart conditions.

The sublingual mucosa under the tongue and in some areas of the mouth is thin and highly vascularized and allows some substances to be rapidly absorbed.

## Stomach

The **stomach**, with its high acidity (pH 1-3), is a significant site for the absorption of weak organic acids, which exist in a diffusible, nonionized and lipid-soluble form. In contrast, weak bases will be highly ionized and therefore poorly absorbed. The acidic stomach may chemically break down some substances. For this reason, those substances must be administered in gelatin capsules or coated tablets, which can pass through the stomach into the intestine before they dissolve and release their contents.

Another determinant that affects the amount of a substance that will be absorbed in the stomach is the presence of food in the stomach. Food ingested at the same time as the xenobiotic may result in a considerable difference in absorption of the xenobiotic.

## Intestine

The greatest absorption of chemicals, as with nutrients, takes place in the **intestine**, particularly in the small intestine. The intestine has a large surface area consisting of outward projections of the thin (one-cell thick) mucosa into the lumen of the intestine (the villi) (Figure 10.2.2). This large surface area facilitates diffusion of substances across the cell membranes of the intestinal mucosa.

Since the pH is near neutral (pH 5-8), both weak bases and weak acids are nonionized and are usually readily absorbed by passive diffusion. Lipid soluble, small molecules effectively enter the body from the intestine by passive diffusion.

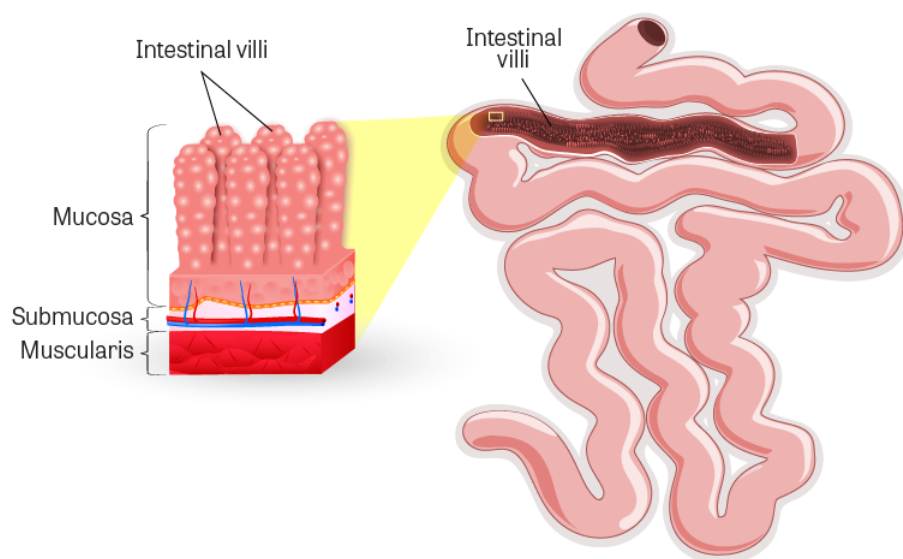

Figure 10.2.2 Anatomy of structures in small intestine used for absorption  
(Image Source: adapted from iStock Photos, ©)

In addition to passive diffusion, facilitated and active transport mechanisms move certain substances across the intestinal cells into the body, including essential nutrients such as glucose, amino acids, and calcium. These mechanisms also transport strong acids,

strong bases, large molecules, and metals, including some important toxins.

- For example, lead, thallium, and paraquat (herbicide) are toxins that active transport systems move across the intestinal wall.

The slow movement of ingested substances through the intestinal tract can influence their absorption. This slow passage increases the length of time that a compound is available for absorption at the intestinal membrane barrier.

Intestinal microflora and gastrointestinal enzymes can affect the toxicity of ingested substances. Some ingested substances may be only poorly absorbed but they may be biotransformed within the gastrointestinal tract. In some cases, their biotransformed products may be absorbed and be more toxic than the ingested substance.

- An important example is the formation of carcinogenic nitrosamines from non-carcinogenic amines by intestinal flora.

## Colon and Rectum

Very little absorption takes place in the **colon** and **rectum**. As a rule, if a xenobiotic has not been absorbed after passing through the stomach or small intestine, very little further absorption will occur. However, there are some exceptions, as some medicines may be administered as rectal suppositories with significant absorption.

- An example is Anusol (hydrocortisone preparation) used for the treatment of local inflammation which is partially absorbed (about 25%).

### Knowledge Check

1) The most important factor that determines whether a substance will be absorbed within the stomach is the:

- a) Physical form as a solid or liquid
- b) Molecular size
- c) pH

#### Answer

pH - **This is the correct answer.**

The most important factor that determines absorption within the stomach is pH. Weak organic acids, which exist in a diffusible, nonionized and lipid-soluble form are readily absorbed in the high acidity of the stomach (pH 1-3). In contrast, weak bases will be highly ionized and therefore poorly absorbed.

2) The primary routes for absorption of environmental agents are:

- a) Gastrointestinal tract, respiratory tract, and skin
- b) Conjunctival exposures and skin wounds

#### Answer

Gastrointestinal tract, respiratory tract, and skin - **This is the correct answer.**

Environmental agents may be found in contaminated food, water, or air. As such, they may be ingested, inhaled, or present on the skin.

3) The site of the gastrointestinal tract where most absorption takes place is:

- a) Stomach
- b) Small intestine
- c) Colon and rectum

#### Answer

Small intestine - **This is the correct answer.**

By far, the greatest absorption takes place in the intestine. This is due to the neutral pH and the large, thin, surface area that

allows easy penetrable by passive diffusion. Weak bases, weak acids, lipid soluble substances and small molecules effectively enter the body from the intestine. In addition, special carrier-mediated and active transport systems exist.

This page titled [10.2: Gastrointestinal Tract](#) is shared under a [CC BY-NC 4.0](#) license and was authored, remixed, and/or curated by [ToxMSDT Online component](#) via [source content](#) that was edited to the style and standards of the LibreTexts platform.

## 10.3: Respiratory Tract

# Respiratory Tract

Many environmental and occupational agents as well as some pharmaceuticals enter the respiratory tract through inhalation. Absorption can occur at any place within the upper respiratory tract. However, the amount of a particular xenobiotic that can be absorbed at a specific location depends highly on its physical form and solubility.

There are three basic regions to the respiratory tract:

1. Nasopharyngeal region
2. Tracheobronchial region
3. Pulmonary region

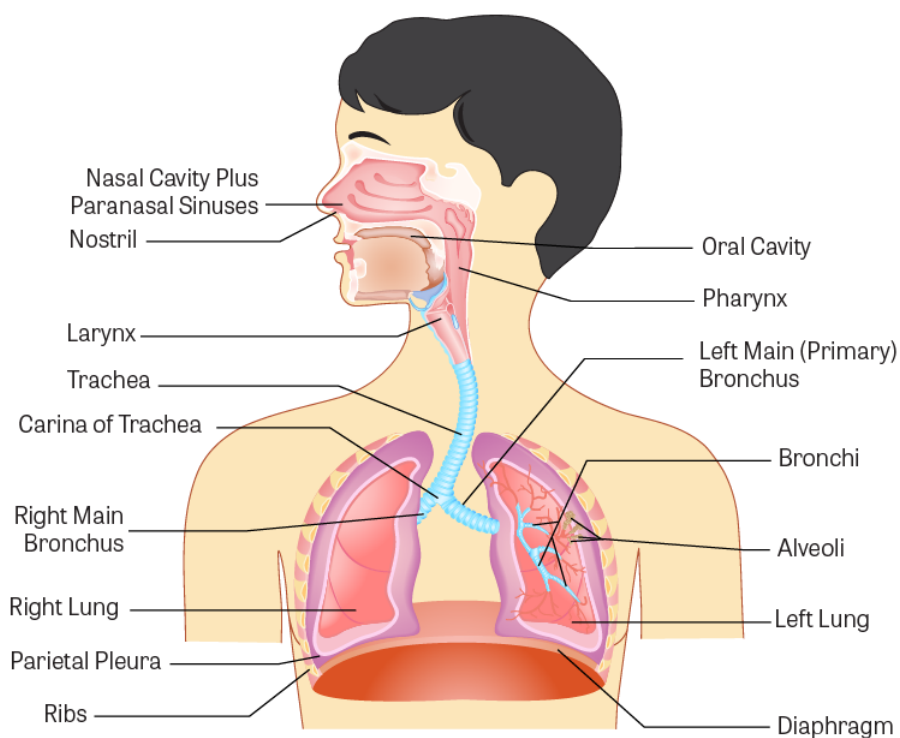
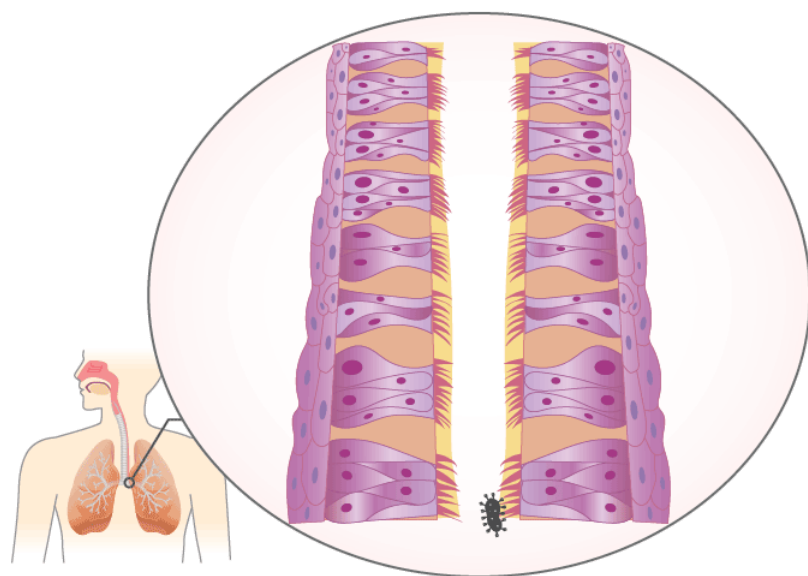

Figure 10.3.1 Anatomy of the respiratory tract  
(Image Source: adapted from iStock Photos, ©)

## Mucociliary Escalator

The mucociliary escalator covers most of the bronchi, bronchioles, and nose. It contains mucus-producing goblet cells and ciliated epithelium. The movements of the cilia push it and anything in it such as inhaled particles or microorganisms up and out into the throat, which can either get swallowed or removed through the mouth.





Animation 10.3.1. The mucociliary escalator provides a barrier against infection

## Pulmonary Region

By far, the most important site for absorption is the pulmonary region consisting of the very small airways called bronchioles and the alveolar sacs of the lung.

The alveolar region has a very large surface area, about 50 times that of the skin. In addition, the alveoli consist of only a single layer of cells with very thin membranes that separate the inhaled air from the blood stream. Oxygen, carbon dioxide, and other gases readily pass through this membrane. Gases and particles, which are water-soluble (and thus blood-soluble), are absorbed more efficiently from the lung alveoli compared to their absorption via the gastrointestinal tract or through the skin. Water-soluble gases and liquid aerosols can pass through the alveolar cell membrane by simple passive diffusion.

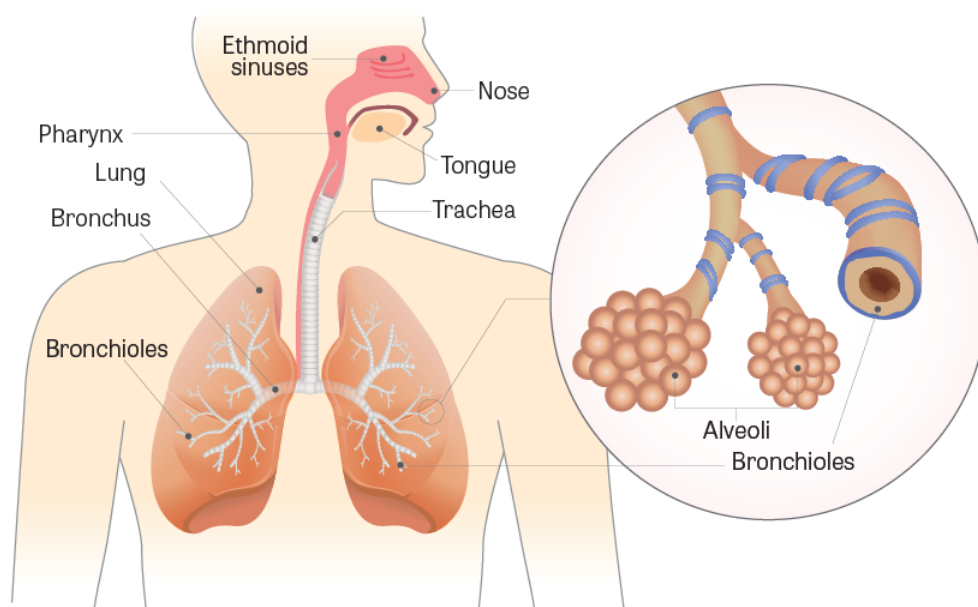

Figure 10.3.2 Detailed view of alveoli and bronchioles  
(Image Source: adapted from iStock Photos, ©)

## Impact of Physical Form on Absorption

In addition to solubility, the ability to be absorbed depends highly on the physical form of the agent (that is, whether the agent is a gas/vapor or a particle). The physical form determines the extent of its penetration into the deep lung.

### Gases and Vapors

A **gas** or **vapor** can be inhaled deep into the lung and if it has high solubility in the blood, it is almost completely absorbed in one respiration (a single breath). Absorption through the alveolar membrane is by passive diffusion, following the concentration gradient. As the agent dissolves in the circulating blood, it leaves the lung and a large amount of gas or vapor can be absorbed and enter the body.

*Blood-soluble* gases or vapors can often be exhaled instead of absorbed right away. For blood-soluble gases, the equilibrium between the concentration of the agent in the inhaled air and that in the blood is difficult to achieve. Inhaled gases or vapors, which have poor solubility in the blood, have a limited capacity for absorption. The main reason for this is that the blood can become quickly saturated. Once saturated, blood will not be able to accept the gas and it will remain in the inhaled air and then get exhaled. One way that the amount of gas absorbed could increase is if the rate and depth of breathing were increased (this concept is known as ventilation limitation). More specifically, the amount of gas absorbed could be increased if the rate of blood supply to the lung were increased by [flow limitation](#).

In contrast, *insoluble* gases or vapors can be absorbed into the body by the lungs before getting exhaled (for example, nitrogen dioxide and carbon monoxide). This is because the equilibrium between the inhaled air and the blood is reached more quickly for relatively insoluble gases than for soluble gases.

### Airborne Particles

The absorption of airborne particles is usually quite different from that of gases or vapors. The absorption of solid particles, regardless of solubility, depends upon particle size:

- Large particles ( $>5\ \mu\text{M}$ ) are generally deposited in the nasopharyngeal (head airways region) region with little absorption.
- Particles  $2\text{-}5\ \mu\text{M}$  can penetrate into the tracheobronchial region.
- Very small particles ( $<1\ \mu\text{M}$ ) are able to penetrate deep into the alveolar sacs where they can deposit and be absorbed.

## Differences in Absorption Among Regions of the Respiratory Tract

### Nasopharyngeal Region

Minimal absorption takes place in the nasopharyngeal region due to the cell thickness of the mucosa and the rapid movement of gases and particles through the region.

### Tracheobronchial Region

Relatively soluble gases can quickly enter the blood stream. Most deposited particles are moved back up to the mouth where they are swallowed.

### Pulmonary Region

Absorption in the **alveoli** of the pulmonary region is quite efficient compared to other areas of the respiratory tract. Relatively soluble materials (gases or particles) are quickly absorbed into systemic circulation. Pulmonary macrophages exist on the surface of

the alveoli. They are not fixed and not a part of the alveolar wall. They can engulf particles just as they engulf and kill microorganisms. These alveolar macrophages can scavenge and clear some insoluble particle into the lymphatic system.

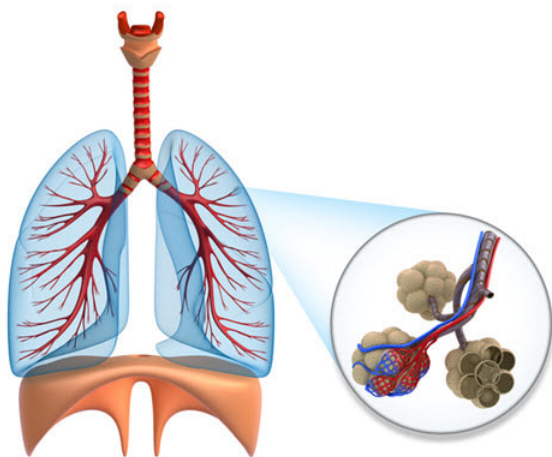

Figure 10.3.3 Alveoli

(Image Source: iStock Photos, ©)

Some other particles may remain in the alveoli indefinitely. For example:

- Coal dust and asbestos fibers may lead to black lung or asbestosis, respectively.
- Carbon nanotubes (CNT), tiny tube-shaped structures smaller than a human hair, have been found in the lungs long after exposure. CNT are used in materials like polymers and anti-static packaging for their electric, magnetic, and mechanical properties. Studies of what happens to different forms of single-walled and multi-walled carbon nanotubes (CNT) found that pristine CNT could remain in the lung for months or even years after pulmonary deposition. However, some CNT can move to the gastrointestinal (GI) tract via the mucociliary escalator where, if swallowed, there appears to be no uptake of CNT from the GI tract (with a possible exception of the smallest functionalized single-walled CNT). In addition, under some experimental conditions in animals, some carbon nanotubes moved from the alveolar space to the nearby pulmonary region including lymph nodes, subpleura and pleura, and smaller amounts went to distal organs including the liver, spleen, and bone marrow.

## Factors Affecting the Toxicity of Inhaled Materials

The nature of toxicity of inhaled materials depends on whether the material is absorbed or remains within the alveoli and small bronchioles. If the agent is absorbed and is lipid soluble, it can rapidly distribute throughout the body, passing through the cell membranes of various organs or into fat depots. Lipid-soluble substances take a longer time to reach equilibrium than water soluble substances. Chloroform and ether are examples of lipid-soluble substances with high blood solubility.

Non-absorbed foreign material can also cause severe toxic reactions within the respiratory system. These reactions may take the form of chronic bronchitis, alveolar breakdown (emphysema), fibrotic lung disease, and even lung cancer. In some cases, the toxic particles can kill the alveolar macrophages, which results in lowering the body's respiratory defense mechanism.

## Pharmaceuticals Targeted to the Respiratory Tract

Inhaled drug delivery devices can be very effective and safe for getting active agents directly to their site of action. Inhalation is used to deliver locally acting drugs to treat respiratory conditions, including asthma, chronic obstructive pulmonary disease (COPD), and airway infections. Advantages of targeted delivery to the lungs include a more rapid onset of action and an increased therapeutic effect. Depending on the drug inhaled, there can be reduced systemic side effects since a lower dose can deliver the required local concentration.

## Toxicogenomics and Toxicity Testing

Toxicogenomics applies genomics concepts and technologies to study gene and protein activities within a type of tissue or type of cell in response to a chemical exposure. Toxicogenomics helps in the understanding of what genes and proteins interact with a chemical, and what diseases are associated with various genes, proteins, and chemicals. This example used toxicogenomics to evaluate the response of the respiratory tract to one type of inhaled material:

For example, titanium dioxide nanoparticles (TiO<sub>2</sub>NPs) induce lung inflammation in experimental animals and [one study](#) included a comprehensive toxicogenomic analysis of lung responses in mice exposed to six individual TiO<sub>2</sub>NPs exhibiting different sizes, crystalline structure, and surface modifications. The goal was to investigate whether the mechanisms leading to TiO<sub>2</sub>NP-induced lung inflammation are property specific. The results suggest that the severity of lung inflammation is property specific; however, the underlying mechanisms (genes and pathways perturbed) leading to inflammation were the same for all particle types. While the particle size clearly influenced the overall acute lung responses, a combination of small size, crystalline structure, and hydrophilic surface contributed to the long-term pathological effects observed at the highest dose.

### Knowledge Check

#### 1) An inhaled material will most likely be absorbed into the body if it has the following characteristics:

- a) High lipid solubility and poorly ionized
- b) Large particle size and low water solubility
- c) High water solubility and small particle size

##### Answer

High water solubility and small particle size - **This is the correct answer.**

In contrast to absorption via the gastrointestinal tract or through the skin, gases and particles, which are water-soluble (and thus blood soluble), will be absorbed more efficiently from the lung alveoli. Very small particles (<1 μM) are able to penetrate deep into the alveolar sacs where they can deposit and be absorbed.

#### 2) Particles of size 2-5 μM are most likely to settle out in which location of the respiratory tract?

- a) Nasopharyngeal region
- b) Tracheobronchial region
- c) Pulmonary region

##### Answer

Tracheobronchial region - **This is the correct answer.**

Particles 2-5 μM can penetrate into the tracheobronchial region. Very small particles (<1 μM) are able to penetrate deep into the alveolar sacs where they can deposit and be absorbed.

This page titled [10.3: Respiratory Tract](#) is shared under a [CC BY-NC 4.0](#) license and was authored, remixed, and/or curated by [ToxMSDT Online component](#) via [source content](#) that was edited to the style and standards of the LibreTexts platform.

## Dermal Route

In contrast to the thin membranes of the respiratory alveoli and the gastrointestinal villi, the skin is a complex, multilayer tissue. It is relatively impermeable to most ions and aqueous solutions, and serves as a barrier to most xenobiotics.

### Did you know?

[Dimethyl sulfoxide \(DMSO\)](#) has been used in research, human and veterinary medicine, and as a solvent. After applying to the skin, some people can quickly detect a garlic taste as the DMSO is absorbed and enters the body. DMSO also increases the rate of absorption of some other compounds through the skin.

For transdermal drug delivery (TDD), the big challenge is the barrier property of skin, especially the stratum corneum (SC). Different methods have been developed to enhance the penetration of drugs through the skin, with the most popular approach being the use of penetration enhancers (PEs), including natural terpenes. Terpenes, a large and diverse class of organic compounds produced by a variety of plants, are a very safe and effective class of PEs. [Limonene](#) is one example of a terpene used as a penetration enhancer. The main mechanism for the penetration enhancing action of terpenes is the interaction with SC intercellular lipids. The key factor affecting the enhancement is the lipophilicity of the terpenes and the drug molecules.



### Entry of Toxicants via Skin

Some notable toxicants can gain entry into the body following skin contamination. For example:

- Certain commonly used organophosphate pesticides have poisoned agricultural workers following dermal exposure.
- The neurological warfare agent, sarin, readily passes through the skin and can produce quick death to exposed persons.
- Several industrial solvents can cause systemic toxicity by penetrating the skin. For example:
  - Carbon tetrachloride enters the skin and causes liver injury.
  - Hexane can pass through the skin and cause nerve damage.

The skin consists of three main layers of cells as illustrated in Figure 10.4.1:

1. Epidermis
2. Dermis
3. Subcutaneous tissue

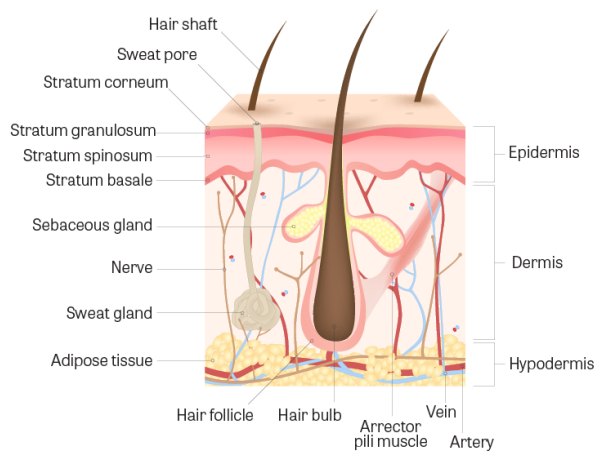

Figure 10.4.1. Layers of the skin  
(Image Source: Adapted from iStock Photos, ©)

### Epidermis and Stratum Corneum

The epidermis (and particularly the stratum corneum) is the only layer that is important in regulating the penetration of a skin contaminant. It consists of an outer layer of cells, packed with keratin, known as the **stratum corneum** layer. The stratum corneum is devoid of blood vessels. The cell walls of the keratinized cells are apparently double in thickness due to the presence of the keratin, which is chemically resistant and an impenetrable material. The blood vessels are usually about 100  $\mu\text{m}$  from the skin surface. To enter a blood vessel, an agent must pass through several layers of cells that are generally resistant to penetration by chemicals.

### Factors Influencing Penetration of the Stratum Corneum

#### Thickness

The thickness of the stratum corneum varies greatly with regions of the body. The stratum corneum of the palms and soles is very thick (400-600  $\mu\text{m}$ ) whereas that of the arms, back, legs, and abdomen is much thinner (8-15  $\mu\text{m}$ ). The stratum corneum of the axillary (underarm) and inguinal (groin) regions is the thinnest with the scrotum especially thin. As expected, the ability of toxicants to penetrate that stratum corneum inversely relates to the thickness of the epidermis.

## Damage

Any process that removes or damages the stratum corneum can enhance penetration of a xenobiotic. Abrasion, scratching, or cuts to the skin will make it more penetrable. Some acids, alkalis, and corrosives can injure the stratum corneum and make it easier for agents to penetrate this layer. The most prevalent skin conditions that enhance dermal absorption are skin burns and dermatitis.

## Passive Diffusion

Toxicants move across the stratum corneum by passive diffusion. There are no known active transport mechanisms functioning within the epidermis. Polar and nonpolar toxicants diffuse through the stratum corneum by different mechanisms:

- **Polar compounds**, which are water soluble, appear to diffuse through the outer surface of the hydrated keratinized layer.
- **Nonpolar compounds**, which are lipid soluble, dissolve in and diffuse through the lipid material between the keratin filaments.

## Water

Water plays an important role in dermal absorption. Normally, the stratum corneum is partially hydrated (approximately 7% by weight). Penetration of polar substances is about 10 times more effective than when the skin is completely dry. Additional hydration on the skin's surface increases penetration by 3–5 times, which further increases the ability of a polar compound to penetrate the epidermis.

## Species

Skin penetration can vary by species which can influence the selection of species used for safety testing. Penetration of chemicals through the skin of the monkey, pig, and guinea pig is often similar to that of humans. The skin of the rat and rabbit is generally more permeable whereas the skin of the cat is generally less permeable. For practical reasons and to assure adequate safety, the rat and rabbit have been used for dermal toxicity safety tests.

## Other Sites of Dermal Absorption

In addition to the stratum corneum, small amounts of chemicals may be absorbed through the sweat glands, sebaceous glands, and hair follicles. However, since these structures represent only a very small percentage of the skin's total surface area, they are not ordinarily viewed as important contributors to dermal absorption.

## Dermis and Subcutaneous Tissue

Once a substance penetrates through the stratum corneum, it enters lower layers of the epidermis, the dermis, and subcutaneous tissue. These layers are far less resistant to further diffusion. They contain a porous, nonselective aqueous diffusion medium which can be penetrated by simple diffusion. Most toxicants that have passed through the stratum corneum can now readily move through the remainder of the skin and enter the circulatory system via the large numbers of venous and lymphatic capillaries in the dermis.

## Semivolatile Organic Compounds (SVOCs)

Exposure to [semivolatile organic compounds \(SVOCs\)](#) via the dermal route can occur. The amount of SVOCs absorbed via air-to-skin uptake has been estimated to be comparable to or larger than the amount taken in via inhalation for many SVOCs encountered indoors, including:

- Butylated hydroxytoluene (BHT)
- Chlordane
- Chlorpyrifos
- Diethyl phthalate
- Nicotine (in free-base form)
- Other chemicals

The influence of particles and dust on dermal exposure, the role of clothing and bedding as transport vectors, and the potential significance of hair follicles as transport shunts through the epidermis are all areas of research interest.

Human exposure to indoor SVOCs through the dermal pathway has often been underestimated and not considered in exposure assessments. However, exposure scientists, risk assessors, and public health officials are increasingly aware of and interested in the health impacts of dermal exposure. Further, experts seek to understand how health consequences can vary by the exposure pathway. For example, an SVOC that enters the blood through the skin does not encounter the same detoxification pathways that it would encounter when ingested and processed by the stomach, intestines, and liver before entering the blood; its direct entry into the blood can make it potentially more toxic.



Figure 10.4.2 Examples of SVOCs from consumer goods  
(Image Source: Adapted from iStock Photos, ©)

### Knowledge Check

1) The main barrier to dermal absorption is the:

- Stratum corneum
- Dermis
- Subcutaneous tissue

**Answer**

Stratum corneum - **This is the correct answer.**

The epidermis (and particularly the stratum corneum) is the only layer that is important in regulating penetration of a skin contaminant.

2) The two primary factors that can increase dermal penetration are:

- a) Neutralizing pH and aerosolizing
- b) Increasing hydration and disruption of the stratum corneum
- c) Dehydrating a substance and increasing particle size

**Answer**

Increasing hydration and disruption of the stratum corneum - **This is the correct answer.**

Water plays an important role in dermal absorption. Normally, the stratum corneum is partially hydrated (~7% by weight). Penetration of polar substances is about 10 times as effective as when the skin is completely dry. Additional hydration can increase penetration by 3-5 times which further increases the ability of a polar compound to penetrate the epidermis. Any process that removes or damages the stratum corneum can enhance penetration of a xenobiotic.

This page titled [10.4: Dermal Route](#) is shared under a [CC BY-NC 4.0](#) license and was authored, remixed, and/or curated by [ToxMSDT Online component](#) via [source content](#) that was edited to the style and standards of the LibreTexts platform.



## 10.5: Other Routes of Exposure

# Other Routes of Exposure

In addition to the common routes of environmental, occupational, and medical exposure (oral, respiratory, and dermal), other routes of exposure may be used for medical purposes. Many pharmaceuticals are given by parenteral routes via injection into the body using a syringe and hollow needle.

## Other Exposure Routes

**Intradermal injections** are made directly into the skin, just under the stratum corneum. Tissue reactions are minimal and absorption is usually slow. A **subcutaneous injection** is beneath the skin. Since the subcutaneous tissue is quite vascular (consisting of vessels especially those carrying blood), absorption into the systemic circulation is generally rapid. Tissue sensitivity is also high and thus irritating substances may induce pain and an inflammatory reaction.

The **intramuscular** route is used to inject many pharmaceuticals, especially antibiotics and vaccines, directly into muscle tissue. It is an easy procedure and the muscle tissue is less likely to become inflamed compared to subcutaneous tissue. Absorption from muscle is about the same as from subcutaneous tissue.

The **intravenous** (vein) or **intra-arterial** (artery) routes are used to inject substances directly into large blood vessels when they are irritating or when an immediate action is desired, such as anesthesia.

**Parenteral** injections may also be made directly into body cavities, rarely in humans but frequently in laboratory animal studies. An **intraperitoneal injection** goes directly into the abdominal cavity and an **intrapleural injection** directly into the chest cavity. Since the pleura and peritoneum have minimal blood vessels, irritation is usually minimal and absorption is relatively slow.



Figure 10.5.1 Injection using a syringe  
(Image Source: iStock Photos, ©)

**Implantation** is another route of exposure of increasing concern. A large number of pharmaceuticals and medical devices are now implanted in various areas of the body. Implants may be used to allow slow, time-release of a substance such as hormones. Implanted medical devices and materials like artificial lenses, tendons, and joints, and cosmetic reconstruction do not involve absorption.

Some materials enter the body via **skin penetration** as the result of accidents or violence (weapons, etc.). The absorption in these cases depends highly on the nature of the substance. Metallic objects (such as bullets) may be poorly absorbed whereas more



soluble materials that thrust through the skin and into the body from accidents may be absorbed rapidly into the circulation.

Novel methods of introducing substances into specific areas of the body are often used in medicine. For example, **conjunctival instillations** (eye drops) treat ocular conditions where high concentrations are needed on the outer surface of the eye, not possible by other routes.

Therapies for certain conditions require that a substance is deposited in body openings where high concentrations and slow release may be needed while keeping systemic absorption to a minimum. For these substances, the pharmaceutical agent is suspended in a poorly absorbed material such as beeswax with the material known as a **suppository**. The usual locations for use of suppositories are the rectum and vagina.

## Did you know?

**Cinnamic aldehyde**, also called **cinnamaldehyde**, gives cinnamon its flavor and odor. It occurs naturally in the bark of cinnamon trees and other species. Cinnamic aldehyde and cinnamic alcohol are well known in the scientific literature as being associated with skin allergy in humans. Skin allergy is also called skin sensitization or allergic contact dermatitis. Cinnamic aldehyde is a more potent sensitizer than cinnamic alcohol. The skin absorption and metabolism of cinnamic aldehyde and cinnamic alcohol play an important role in the development of skin sensitization following skin exposures. Cinnamic alcohol applied to human skin is converted to cinnamic aldehyde and cinnamic acid.

Cinnamic aldehyde is a good example of how an assessment of the risk of skin sensitization can be conducted prior to the introduction of new ingredients and products into the marketplace. A [published quantitative risk assessment](#) for cinnamic aldehyde used the understanding of its chemical, cellular, and molecular properties. By estimating the exposure to cinnamic aldehyde and knowing its allergenic potency, it was possible to assess the sensitization risk of cinnamic aldehyde in different types of consumer products. This publication applied exposure-based risk assessment tools to two hypothetical products containing cinnamic aldehyde. The risk assessment predicted that an eau de toilette leave-on product containing 1000 ppm or more of cinnamic aldehyde would pose an *unacceptable risk* of skin sensitization getting induced. However, a shampoo containing the same level of cinnamic aldehyde would pose an *acceptable risk* of skin sensitization getting induced, based on there being limited exposure to the ingredient from a rinse-off product application.



Figure 10.5.2. Cinnamon sticks and powder  
(Image Source: iStock Photos, ©)

### Knowledge Check

- 1) If an immediate therapeutic effect is needed, the route of exposure that would most likely be used is the:
- Intradermal route
  - Intramuscular injection
  - Intravenous injection

**Answer**

Intravenous injection - **This is the correct answer.**

Substances injected into the circulatory system go directly to the target tissue where immediate reactions can occur.

**2) A pharmaceutical may be implanted in the body to:**

- a) Allow slow-release over a long period of time
- b) Assure that the substance is distributed equally throughout the body
- c) Reduce irritation from the substance

**Answer**

Allow slow-release over a long period of time - **This is the correct answer.**

Treatment with pharmaceuticals in time-release implants is a relatively new therapeutic technique that has gained popularity for long-term chronic chemotherapy.

---

This page titled [10.5: Other Routes of Exposure](#) is shared under a [CC BY-NC 4.0](#) license and was authored, remixed, and/or curated by [ToxMSDT Online component](#) via [source content](#) that was edited to the style and standards of the LibreTexts platform.

## CHAPTER OVERVIEW

### Section 11: Distribution

## Learning Objectives

After completing this lesson, you will be able to:

- Explain distribution and its role in toxicokinetics.
- Describe the impact of exposure route on distribution.
- Describe three models of disposition.
- Identify structural barriers to distribution.

## In this section...

Topics include:

[11.1: Introduction to Distribution](#)

[11.2: Influence of Route of Exposure](#)

[11.3: Disposition Models](#)

[11.4: Structural Barriers to Distribution](#)

[11.5: Storage Sites](#)

## Section 11: Key Points

## What We've Covered

This section made the following main points:

- Distribution is the process in which an absorbed chemical moves away from the site of absorption to other areas of the body.
- An absorbed chemical passes through cell linings of the absorbing organ (skin, lung, or gastrointestinal tract) into the interstitial fluid of that organ.
- The toxicant can leave the interstitial fluid by entering local tissue cells, blood capillaries and the blood circulatory system, or the lymphatic system.
- If the toxicant gains entrance into the blood plasma, it:
  - Travels bound or unbound along with the blood.
  - May be excreted, stored, or biotransformed, or may interact or bind with cellular components.
- The volume of distribution (VD) is the total volume (in liters) of body fluids in which a toxicant is distributed.
- The route of exposure is an important factor affecting the concentration of the toxicant or its metabolites at any specific location within the blood or lymph.
  - Toxicants entering from the GI tract or peritoneum are immediately subject to biotransformation or excretion by the liver and elimination by the lung (this is often called the "first-pass effect").
  - Toxicants absorbed through the lung or skin enter the blood and go directly to the heart and systemic circulation, thus being distributed to various organs before going to the liver (not subject to the first-pass effect).
  - Toxicants that enter the lymph will not go to the liver first, but will slowly enter systemic circulation.
  - The blood level of a toxicant depends on the site of absorption and the rate of biotransformation and excretion.
- Disposition is the combined processes of distribution, biotransformation, and elimination. Disposition models can be:

- One-Compartment Open Model — disposition of a substance introduced and distributed instantaneously and evenly in the body and eliminated proportionally to the amount left in the body ("first-order" rate).
- Two-Compartment Open Model — the chemical enters and distributes in the first compartment (usually blood), then distributed to another compartment where it can be eliminated or may return to the first compartment.
  - The biological half-life, the most commonly used measure of the kinetic behavior of a xenobiotic, is the half-life for a chemical in a two-compartment model.
- Multiple Compartment Model — the chemical involves several peripheral body compartments, including long-term storage, or biotransformation and elimination at varying rates as blood levels change.
- Organs or tissues differ in the amount of a chemical they may receive, depending on:
  - Volume of blood — organs that receive larger blood volumes potentially accumulate more of a given toxicant.
  - Tissue affinity — some tissues have a higher affinity for specific chemicals, accumulating a toxicant in great concentrations despite a rather low flow of blood.
- Structural barriers to distribution include the blood-brain barrier and the placental barrier.
- Toxicants can also be stored:
  - When bound to plasma proteins in the blood
  - In adipose tissues
  - In bone
  - In the liver
  - In the kidneys

---

This page titled [Section 11: Distribution](#) is shared under a [CC BY-NC 4.0](#) license and was authored, remixed, and/or curated by [ToxMSDT Online component](#) via [source content](#) that was edited to the style and standards of the LibreTexts platform.

## 11.1: Introduction to Distribution

### Introduction to Distribution

So far, we have described the absorption of substances into the body. Now we will focus on what happens next to substances in the body after they are absorbed.

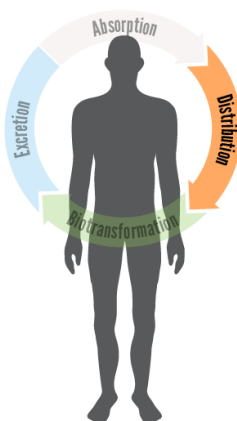

Figure 11.1.1. The processes of toxicokinetics  
(Image Source: Adapted from iStock Photos, ©)

### Distribution Defined

**Distribution** is the process in which an absorbed chemical moves away from the site of absorption to other areas of the body. In this section, we will answer the following questions:

- How do chemicals move through the body?
- Does distribution vary with the route of exposure?
- Is a chemical distributed evenly to all organs or tissues?
- How fast is a chemical distributed?
- Why do some chemicals stay in the body for a long time while others are eliminated quickly?

### Body Fluids

When a chemical is absorbed, it passes through cell linings of the absorbing organ (skin, lung, or gastrointestinal tract) into the **interstitial fluid** (fluid surrounding cells) of that organ. The other body fluids are **intracellular fluid** (fluid inside cells) and **blood plasma**. However, the body fluids are not isolated but represent one large pool. The interstitial and intracellular fluids, in contrast to fast moving blood, remain in place with certain components (for example, water and electrolytes) moving slowly into and out of cells. A chemical, while immersed in the interstitial fluid, is not mechanically transported the way it is in blood. Table 1 lists the approximate percentage of body weight each of these body fluids comprise.

Body fluid	Approximate % of total body weight
Interstitial fluid	15%
Intracellular fluid	40%
Blood plasma	8%

Table 1. Approximate percentages that various body fluids contribute to the total body weight

A toxicant can leave the interstitial fluid by entering:

- Local tissue cells.
- Blood capillaries and the blood circulatory system.
- The lymphatic system.

### Blood Plasma

If the toxicant gains entrance into the blood plasma, it travels along with the blood, either in a bound or unbound form. Blood moves rapidly through the body via the cardiovascular circulatory system. In contrast, lymph (fluid) moves slowly through the lymphatic system. The major distribution of an absorbed chemical is by blood with only minor distribution by lymph. Since virtually all tissues have a blood supply, all organs and tissues of the body are potentially exposed to the absorbed chemical.

Distribution of a chemical to body cells and tissues requires that the toxicant penetrate a series of cell membranes. It must first penetrate the cells of the capillaries (small blood vessels) and later the cells of the target organs. The [factors pertaining to passage across membranes](#) apply to these other cell membranes as well. For example, important factors include the concentration gradient; molecular weight; lipid solubility; and polarity, with the smaller, nonpolar toxicants in high concentrations being most likely to gain entrance.

The distribution of a xenobiotic can be affected by whether it binds to plasma protein. Some toxicants may bind to these plasma proteins (especially albumin), which removes the toxicant from potential cell interaction. Within the circulating blood, the non-bound (free) portion is in equilibrium with the bound portion. However, only the free substance is available to pass through the capillary membranes. Those substances that are extensively bound are limited in terms of equilibrium and distribution throughout the body. Protein binding in the plasma greatly affects distribution, prolongs the half-life within the body, and affects the dose threshold for toxicity.

The plasma level of a xenobiotic is important since it generally reflects the concentration of the toxicant at the site of action. The passive diffusion of the toxicant into or out of these body fluids will be determined mainly by the toxicant's concentration gradient.

## Volume of Distribution (written as $V$ subscript $D$ - see example in formula below)

The **apparent volume of distribution (VD)** is the total volume of body fluids in which a toxicant is distributed. The VD is expressed in liters.

If a toxicant is distributed only in the plasma fluid, the plasma concentration will remain high and a low VD results; however, if a toxicant is distributed in all sites (blood plasma, interstitial, and intracellular fluids) there is greater dilution in plasma concentration and a higher VD will result. Binding in effect reduces the concentration of free toxicants in the plasma or VD. Toxicants that undergo rapid storage, biotransformation, or elimination further affect the VD. Toxicologists determine the VD of a toxicant in order to know how extensively a toxicant is distributed in the body fluids. The volume of distribution can be calculated by the formula:

$$V_D = \frac{\text{dose (mg)}}{\text{plasma conc (mg/L)}}$$

The volume of distribution may provide useful estimates as to how extensive the toxicant is distributed in the body. For example, a very high apparent VD may indicate that the toxicant has distributed to a particular tissue or storage area such as adipose tissue. In addition, the body burden for a toxicant can be estimated from knowledge of the VD by using the formula:

$$\text{body burden (mg)} = \text{plasma conc (mg/L)} \times V_D \text{ (L)}$$

Once a chemical is in the blood stream:

- It may be excreted.
- It may be stored.
- It may be biotransformed into different chemicals (metabolites).
- Its metabolites may be excreted or stored.
- The chemical or its metabolites may interact or bind with cellular components.

Most chemicals undergo some biotransformation. The degree with which various chemicals are biotransformed and the degree with which the parent chemical and its metabolites are stored or excreted vary with the nature of the exposure (dose level, frequency, and route of exposure).

### Knowledge Check

1) When an ingested toxicant is absorbed, it passes through the cells lining the GI tract into the:

- Intracellular fluid
- Gastric fluid
- Interstitial fluid

#### Answer

Interstitial fluid - **This is the correct answer.**

When a chemical is absorbed it passes through cell linings of the absorbing organ (in this case, the gastrointestinal tract) into the interstitial fluid (fluid surrounding cells) within that organ.

2) The apparent volume of distribution (VD) represents the:

- Total volume of body fluids in which a toxicant is distributed
- Amount of blood plasma in which a toxicant is dissolved
- Amount of interstitial fluid that contains a toxicant

#### Answer

Total volume of body fluids in which a toxicant is distributed - **This is the correct answer.**

The apparent volume of distribution (VD) represents the total volume of body fluids in which a toxicant is distributed. It consists of the interstitial fluid, intracellular fluid, and the blood plasma. Soon after absorption, a toxicant may be distributed to all three types of fluids, although the concentrations may be quite different. Rarely will a toxicant be distributed to only one type of fluid.

This page titled [11.1: Introduction to Distribution](#) is shared under a [CC BY-NC 4.0](#) license and was authored, remixed, and/or curated by [ToxMSDT Online component](#) via [source content](#) that was edited to the style and standards of the LibreTexts platform.

## 11.2: Influence of Route of Exposure

### Influence of Exposure Route

The **route of exposure** is an important factor that can affect the concentration of the toxicant (or its metabolites) at any specific location within the blood or lymph. This can be important since the time and path taken by the chemical as it moves through the body influences the degree of biotransformation, storage, and elimination (and thus toxicity).

For example, if a chemical goes to the liver before going to other parts of the body, much of it may be biotransformed quickly. In this case, the blood levels of the toxicant "downstream" may be diminished or eliminated. This way of processing the chemical right away can dramatically affect its potential toxicity.

### Gastrointestinal Tract and Peritoneum

When toxicants are absorbed through the **gastrointestinal (GI) tract**, a similar biotransformation process occurs. Blood carries absorbed toxicants entering the vascular system of the GI tract directly to the liver via the portal system. This is also true for those drugs administered by intraperitoneal injection. Blood from most of the peritoneum also enters the portal system and goes immediately to the liver. Blood from the liver then flows to the heart and then on to the lung, before going to other organs.

Thus, toxicants entering from the GI tract or peritoneum are immediately subject to biotransformation or excretion by the liver and elimination by the lung. This is often referred to as the "first-pass effect."

For example, first-pass biotransformation of the drug propranolol (cardiac depressant) is about 70% when given orally. This means the blood level of this medication is only about 30% of a comparable dose administered intravenously.

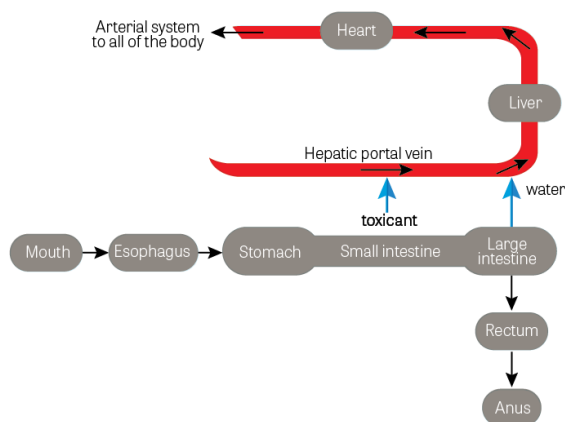

Figure 11.2.1 Movement of a toxicant through the portal system

(Image Source: Adapted from Kimball's Biology Pages. Original author: John W. Kimball, obtained under Creative Commons Attribution 3.0 Unported license, © [View original image.](#))

### Lung and Skin

Drugs and other substances that are absorbed through the **lungs** or **skin** enter the bloodstream to be carried throughout the body. Thus, they avoid the liver (hepatic) first-pass effect that would have occurred if they had been absorbed from the gastrointestinal tract. These substances can have local effects in the lungs or skin in addition to having systemic effects, and some cells in the lungs and skin may metabolize the drug or other substance. Examples of a "local first-pass effect" in the skin due to metabolism are when nitroglycerin and cortisol applied to the skin. Drugs administered intravenously or intramuscularly also enter the bloodstream to be carried throughout the body and avoid the liver (hepatic) first-pass effect.

#### Did you know?

Some advantages of transdermal drug delivery (skin patches):

- They are a better way to deliver substances that are broken down by the stomach acids, not well absorbed from the gut, or extensively broken down by the liver.
- They are a substitute for oral route.
- They permit constant dosing rather than the peaks and valley in medication level associated with orally administered medication.
- They can minimize undesirable side effects.
- They can be used to prescribe drugs that have short biological half-lives or a narrow therapeutic window.
- They can be removed, thereby terminating therapy easily.
- They are noninvasive, avoiding the inconvenience of IV therapy or injections.
- They can be used with patients who are nauseated or unconscious.
- They are cost-effective.



Figure 11.2.2 Nicotine patch  
(Image Source: iStock Photos, ©)

### Lymph

The delivery of drugs and bioactive compounds via the lymphatic system avoids first-pass metabolism by the liver and increases oral bioavailability. It is also a way to deliver drugs for diseases that spread through the lymphatic system such as certain types of cancer and the human immunodeficiency virus (HIV). For example, [liposomes](#) composed of phosphatidylethanol can enhance the oral bioavailability of poorly absorbed hydrophilic drugs such as cefotaxime.

## Blood

The blood levels of a drug or other substance depend on the site of absorption, whether being absorbed after subcutaneous injection or more quickly from intramuscular injection. These blood levels also depend on the individual's rate of local and systemic biotransformation, and the rate of excretion. Uptake and release can occur in areas of the body away from the first site of absorption. Some anesthetics can be taken up by the lungs and later released, impacting blood levels. Lidocaine, given intravenously, is one example of this later release. Further, as noted elsewhere in ToxTutor, the metabolism of a substance can vary widely from person-to-person due to factors such as genetic differences, age, diet, and diseases that affect metabolism.

### Some advantages of intramuscular injections:

- They are absorbed faster than subcutaneous injection, partly because muscle tissue has a larger blood supply than tissue just under the skin.
- They can hold a greater injected volume of drug (or vaccine) than a subcutaneous tissue injection can.
- They can be used instead of intravenous injection if a drug is irritating to veins or if a suitable vein cannot be located.
- They may be used instead of oral delivery if a drug is known to be degraded by stomach acids.

### Knowledge Check

1) The main difference in distribution of a toxicant absorbed from the gastrointestinal tract from toxicants absorbed through the skin or from inhalation is:

- a) The toxicant is distributed to more organs
- b) A greater amount of the toxicant that is absorbed will be distributed to distant parts of the body
- c) The toxicant enters the systemic circulatory system after first passing through the liver

#### Answer

The toxicant enters the systemic circulatory system after first passing through the liver - **This is the correct answer.**

Toxicants that enter the vascular system of the gastrointestinal tract are carried directly to the liver by the portal system. Thus, toxicants are immediately subject to biotransformation or excretion by the liver. This is often referred to as the "first pass effect."

This page titled [11.2: Influence of Route of Exposure](#) is shared under a [CC BY-NC 4.0](#) license and was authored, remixed, and/or curated by [ToxMSDT Online component](#) via [source content](#) that was edited to the style and standards of the LibreTexts platform.



## 11.3: Disposition Models

### Disposition Models

**Disposition** is the term often used to describe the combined processes of distribution, biotransformation, and elimination. The most used disposition models are compartmental models, which are categorized as one-compartment, two-compartment, and multicompartment models. Compartmental models can be used to predict the time course of drug concentrations in the body. These compartments could represent a group of similar tissues or fluids.

For example:

- Blood is a compartment.
- Fat (adipose) tissue, bone, liver, kidneys, and brain are other major compartments.

Kinetic models may be a 1) one-compartment open model; 2) two-compartment open model; or 3) multiple compartment model.

### One-Compartment Model

A **one-compartment open model** may be used for drugs like aminoglycosides which rapidly distribute (equilibrate) to tissues and fluids within the body. In other words, the entire body acts like one uniform compartment. This model is also called a one-compartment open model, with "open" being the assumption that the drug can enter and leave the body via excretion. The figure below shows the disposition of a drug or other substance that distributes instantaneously and evenly in the body, and is eliminated at a rate and amount that is proportional to the amount left in the body. This is known as a "first-order" rate and represented as the logarithm of concentration in blood as a linear function of time (Figure 11.3.1).

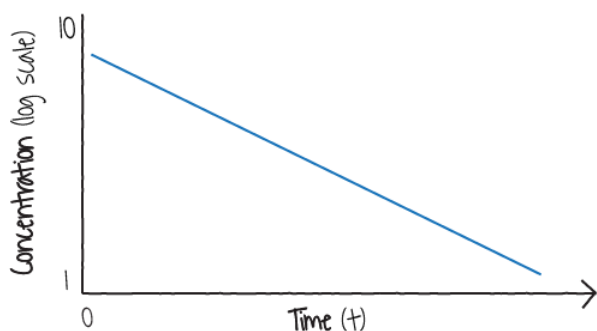

Figure 11.3.1 One-compartment open model  
(Image Source: NLM)

The **half-life** of the chemical that follows a one-compartment model is simply the time required for half of the chemical to be lost from the plasma. Only a few chemicals actually follow the simple, first-order, one compartment model.

### Two-Compartment Model

For most chemicals, it is necessary to describe the kinetics in terms of at least a two-compartment model. A two-compartment model is used for drugs which distribute slowly within the body. This model is also called a two-compartment open model, with "open" being the assumption that the drug can enter and leave the body.

For example, a one-time (bolus) intravenous administration over a short time period could lead to a drug distributing rapidly in the blood and also to highly perfused (by blood) organs like the liver and kidneys. This would be one compartment of the two-compartment model. There would be a slower distribution to other parts of the body as the second compartment.

- Two examples are vancomycin and digoxin. As shown in Figure 11.3.2 the drug or other substance enters and distributes in the first compartment. It is then distributed to another compartment. The concentration in the first compartment declines with time while the concentration in the second compartment rises, peaks, and declines as the chemical is eliminated from the body.

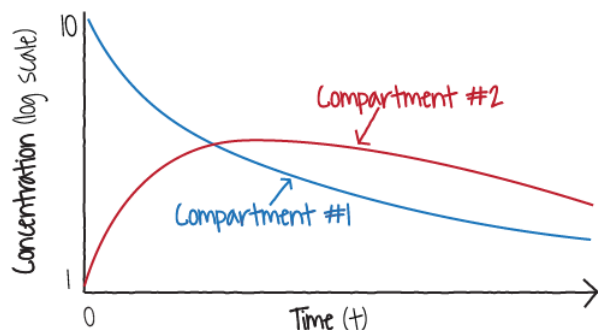

Figure 11.3.1 Two-compartment open model  
(Image Source: NLM)

A half-life for a chemical whose kinetic behavior fits a two-compartment model is often referred to as the "biological half-life." This is the most commonly used measure of the kinetic behavior of a xenobiotic.

## Multiple Compartment Model

Frequently the one- and two-compartment models cannot adequately describe the kinetics of a chemical within the body since there may be several peripheral body compartments to which the chemical may go, including long-term storage. In addition, biotransformation and elimination of a chemical may not be simple processes but subject to different rates as blood levels change.

### Knowledge Check

#### 1) Disposition models describe:

- How a toxicant moves within the body over time
- How the body eliminates the toxicant
- The pathway for biotransformation of the toxicant within the liver

#### Answer

How a toxicant moves within the body over time - **This is the correct answer.**

Disposition models, also known as kinetic models, describe how a toxicant moves within the body compartments with time.

This page titled [11.3: Disposition Models](#) is shared under a [CC BY-NC 4.0](#) license and was authored, remixed, and/or curated by [ToxMSDT Online component](#) via [source content](#) that was edited to the style and standards of the LibreTexts platform.

## 11.4: Structural Barriers to Distribution

# Structural Barriers to Distribution

Organs or tissues differ in the amount of a chemical that they receive or to which they are exposed. This is primarily due to two factors: the 1) **volume of blood** flowing through a specific tissue and the 2) **presence of special barriers** to slow down a toxicant's entrance.

## Volume of Blood and Tissue Affinity

Organs that receive larger **blood volumes** can potentially accumulate more of a given toxicant. Body regions that receive a large percentage of the total cardiac output include the liver (28%), kidneys (23%), heart muscle, and brain. Bone and adipose tissues have relatively low blood flow, even though they serve as primary storage sites for many toxicants. This is especially true for toxicants that are fat-soluble and those that readily associate (or form complexes) with minerals commonly found in bone.

**Tissue affinity** determines the degree of concentration of a toxicant. In fact, some tissues have a higher affinity for specific chemicals and accumulate a toxicant in great concentrations despite a rather low flow of blood.

For example, adipose tissue, which has a meager blood supply, concentrates lipid-soluble toxicants. Once deposited in these storage tissues, toxicants may remain for long periods, due to their solubility in the tissue and the relatively low blood flow.

## Structural Barriers

During distribution, the passage of toxicants from capillaries into various tissues or organs is not uniform. **Structural barriers** exist that restrict the entrance of toxicants into certain organs or tissues. The primary barriers are those of the brain, placenta, and testes.

### Blood-Brain Barrier

The **blood-brain barrier** protects the brain from most toxicants. Specialized cells called astrocytes possess many small branches, which form a barrier between the capillary endothelium and the neurons of the brain. Lipids in the astrocyte cell walls and very tight junctions between adjacent endothelial cells limit the passage of water-soluble molecules. The blood-brain barrier is not completely impenetrable and its penetrability can vary with health status/disease state, but it does slow down the rate at which toxicants cross into brain tissue while allowing essential nutrients, including oxygen, to pass through.

### Placental Barrier

The **placental barrier** protects the sensitive, developing fetus from most toxicants distributed in the maternal circulation. This barrier consists of several cell layers between the maternal and fetal circulatory vessels in the placenta. Lipids in the cell membranes limit the diffusion of water-soluble toxicants. However, nutrients, gases, and wastes of the developing fetus can pass through the placental barrier. As in the case of the blood-brain barrier, the placental barrier is not completely impenetrable but effectively slows down the diffusion of most toxicants from the mother into the fetus.

#### Knowledge Check

**1) Organs may differ greatly in the concentration of a toxicant in them, due primarily to the:**

- a) Rate of elimination of the toxicant by the kidneys
- b) Distance of the organ from the heart since the toxicant disintegrates quickly in the blood plasma
- c) Volume of blood flow and the presence of special barriers

#### Answer

Volume of blood flow and the presence of special barriers - **This is the correct answer.**

Organs or tissues differ in the amount of a chemical that they receive or to which they are exposed. This is primarily due to

two factors, the **volume of blood** flowing through a specific tissue and the **presence of special "barriers"** to slow down toxicant entrance. Organs that receive larger blood volumes can potentially accumulate more of a given toxicant.

## 2) The placental barrier protects the fetus from toxicants in the maternal blood because:

- a) Substances in the maternal blood must move through several layers of cells in order to gain entrance to placental blood
- b) The placenta does not contain circulating fetal blood that can absorb toxicants from the maternal blood
- c) Toxicants in maternal blood are usually lipid soluble and must be water-soluble in order to penetrate through the placental cell layers

### Answer

Substances in the maternal blood must move through several layers of cells in order to gain entrance to placental blood -

**This is the correct answer.**

The placental barrier protects the developing and sensitive fetus from most toxicants distributed in the maternal circulation. This barrier consists of several cell layers between the maternal and fetal circulatory vessels in the placenta. Lipids in the cell membranes limit the diffusion of water-soluble toxicants.

---

This page titled [11.4: Structural Barriers to Distribution](#) is shared under a [CC BY-NC 4.0](#) license and was authored, remixed, and/or curated by [ToxMSDT Online component](#) via [source content](#) that was edited to the style and standards of the LibreTexts platform.

## 11.5: Storage Sites

# Storage Sites

**Storage** of toxicants in body tissues sometimes occurs. Initially, when a toxicant enters the blood plasma, it may be bound to plasma proteins. Toxicants attached to proteins are considered a form of storage because they do not contribute to the chemical's toxic potential. Albumin is the most abundant plasma protein that binds toxicants. Normally, the toxicant is only bound to the albumin for a relatively short time.

The primary sites for toxicant storage are adipose tissue, bone, liver, and kidneys.

## Adipose Tissue

Lipid-soluble toxicants are often stored in **adipose tissues**. Adipose tissue is located in several areas of the body but mainly in subcutaneous tissue. Lipid-soluble toxicants can be deposited along with triglycerides in adipose tissues. The lipids are in a continual exchange with blood and thus the toxicant may be mobilized into the blood for further distribution and elimination, or redeposited in other adipose tissue cells.

## Bone

**Bone** is another major site for storage. Bone is composed of proteins and the mineral salt hydroxyapatite. Bone contains a sparse blood supply but is a live organ. During the normal processes that form bone, calcium and hydroxyl ions are incorporated into the hydroxyapatite-calcium matrix. Several chemicals, primarily elements, follow the same kinetics as calcium and hydroxyl ions and therefore can be substituted for them in the bone matrix.

For example, strontium (Sr) or lead (Pb) may be substituted for calcium (Ca), and fluoride (F-) may be substituted for hydroxyl (OH-) ions. Bone is continually being remodeled under normal conditions. Calcium and other minerals are continually being resorbed and replaced, on the average about every 10 years. Thus, any toxicants stored in the matrix will eventually be released to re-enter the circulatory system.

## Liver and Kidneys

The **liver** is a storage site for some toxicants. It has a large blood flow and its hepatocytes (that is, liver cells) contain proteins that bind to some chemicals, including toxicants.

As with the liver, the **kidneys** have a high blood flow, which preferentially exposes these organs to toxicants in high concentrations. Storage in the kidneys is associated primarily with the cells of the nephron (the functional unit for urine formation).

### Knowledge Check

#### 1) The areas of the body which most frequently store toxicants are:

- a) Adrenal gland, thyroid gland, and pancreas
- b) Adipose tissue, bone, liver, and kidney
- c) Skeletal muscle, tendons, and leg joints

#### Answer

1) Adipose tissue, bone, liver, and kidney - **This is the correct answer.**

The primary sites for toxicant storage are adipose tissue, bone, liver and kidneys. Lipid-soluble toxicants store in adipose tissues; chemicals that follow calcium or hydroxyl ion kinetics store in bone; and the liver and kidney cells are subjected to high concentrations of toxicants.

This page titled [11.5: Storage Sites](#) is shared under a [CC BY-NC 4.0](#) license and was authored, remixed, and/or curated by [ToxMSDT Online component](#) via [source content](#) that was edited to the style and standards of the LibreTexts platform.

## CHAPTER OVERVIEW

### Section 12: Biotransformation

## Learning Objectives

After completing this lesson, you will be able to:

- Explain biotransformation, including its importance to survival and the body sites it involves.
- Define enzymes and the three types of enzyme specificity.
- Explain the two phases of biotransformation.
- Identify factors that influence the effectiveness of biotransformation.

## In this section...

Topics include:

- [12.1: Introduction to Biotransformation](#)
- [12.2: Chemical Reactions](#)
- [12.3: Biotransformation Sites](#)
- [12.4: Modifiers of Biotransformation](#)

### Section 12: Key Points

## What We've Covered

This section made the following main points:

- Biotransformation is the process by which a substance changes from one chemical to another (transformed) by a chemical reaction within the body.
- Biotransformation is vital to survival because it transforms absorbed nutrients into substances required for normal body functions.
- Potential complications of biotransformation include:
  - Detoxification — biotransformation results in metabolites of lower toxicity than the parent substance.
  - Bioactivation — biotransformation results in metabolites of greater toxicity than the parent substance.
- Chemical reactions continually occur in the body to build up new tissue, tear down old tissue, convert food to energy, dispose of waste materials, and eliminate toxic xenobiotics.
- Enzymes are catalysts for nearly all biochemical reactions in the body; essential biotransformation reactions would be slowed or prevented without these enzymes, causing major health problems.
- There are generally three types of enzyme specificity:
  1. Enzymes with absolute specificity catalyze only one reaction.
  2. Enzymes with group specificity act only on molecules that have specific functional groups.
  3. Enzymes with linkage specificity act on a particular type of chemical bond regardless of the rest of the molecular structure.
- There are two biotransformation reaction phases:
  1. Phase I reactions modify the chemical by adding a functional structure, allowing the substance to "fit" into a second (Phase II) enzyme:
    - Oxidation — the substrate loses electrons.
    - Reduction — the substrate gains electrons.
    - Hydrolysis — the addition of water splits the toxicant into two fragments or smaller molecules.

2. Phase II reactions conjugate (join together) the modified xenobiotic with another substance. The most important Phase II reactions are:
- Glucuronide conjugation, a high-capacity pathway — glucuronic acid is added directly to the toxicant or its Phase I metabolite, generally resulting in hydrophilic conjugates excreted by the kidney or bile.
  - Sulfate conjugation, a low-capacity pathway — decreases the toxicity of xenobiotics, resulting in highly polar sulfate conjugates readily secreted in the urine.
- Biotransformation sites are the:
    - Liver (primary site, which also makes it the most susceptible to damage by ingested toxicants).
    - Kidneys (about 10-30% of the liver's capacity).
    - Skin, intestines, testes, and placenta (low capacity).
  - Biotransformation effectiveness depends on factors that can inhibit or induce enzymes and dose levels, including species, age, gender, genetic variability, nutrition, disease, exposure to other chemicals, and the dose level.
- 

This page titled [Section 12: Biotransformation](#) is shared under a [CC BY-NC 4.0](#) license and was authored, remixed, and/or curated by [ToxMSDT Online component](#) via [source content](#) that was edited to the style and standards of the LibreTexts platform.

## 12.1: Introduction to Biotransformation

**Biotransformation** is the process by which a substance changes from one chemical to another (transformed) by a chemical reaction within the body. **Metabolism** or **metabolic transformations** are terms frequently used for the biotransformation process. However, metabolism is sometimes not specific for the transformation process but may include other phases of toxicokinetics.

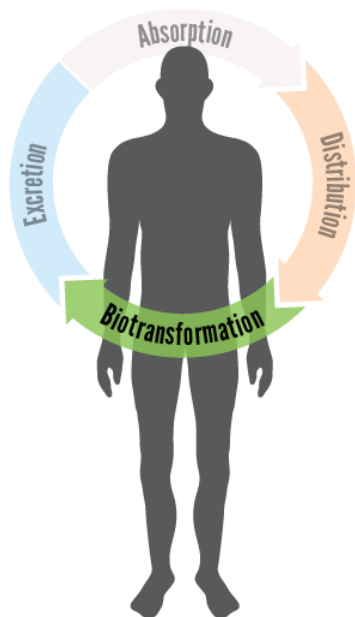

Figure 12.1.1. Processes of toxicokinetics (Image Source: Adapted from iStock Photos, ©)

### Importance of Biotransformation

**Biotransformation** is vital to survival because it transforms absorbed nutrients (food, oxygen, etc.) into substances required for normal body functions. For some pharmaceuticals, it is a metabolite that is therapeutic and not the absorbed drug. For example, phenoxybenzamine, a drug given to relieve hypertension caused by pheochromocytoma, a kind of tumor, is biotransformed into a metabolite, which is the active agent. Biotransformation also serves as an important defense mechanism since toxic xenobiotics and body wastes are converted into less harmful substances and substances that can be excreted from the body.

Toxicants that are lipophilic, non-polar, and of low molecular weight are readily absorbed through the cell membranes of the skin, GI tract, and lung. These same chemical and physical properties control the distribution of a chemical throughout the body and its penetration into tissue cells. Lipophilic toxicants are hard for the body to eliminate and can accumulate to hazardous levels. However, most lipophilic toxicants can be transformed into hydrophilic metabolites that are less likely to pass through membranes of critical cells. Hydrophilic chemicals are easier for the body to eliminate than lipophilic substances. Biotransformation is thus a key body defense mechanism.

Fortunately, the human body has a well-developed capacity to biotransform most xenobiotics as well as body wastes.

#### Did you know?

Hemoglobin, the oxygen-carrying iron-protein complex in red blood cells, is an example of a body waste that must be eliminated. The normal destruction of aged red blood cells releases hemoglobin. Bilirubin is one of several hemoglobin metabolites. If the body cannot eliminate bilirubin via the liver because of disease, medicine, or infection, bilirubin builds up in the body and the whites of the eyes and the skin may look yellow. Bilirubin is toxic to the brain of newborns and, if present in [high concentrations](#), may cause irreversible brain injury. Biotransformation of the lipophilic bilirubin molecule in the liver results in the production of water-soluble (hydrophilic) metabolites excreted into bile and eliminated via the feces.



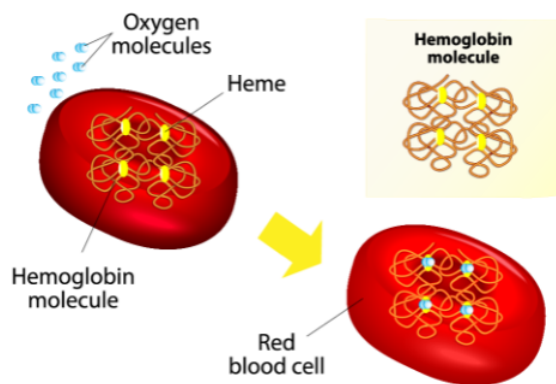

Figure 12.1.2 Human hemoglobin (Image Source: Adapted from iStock Photos, ©)

## Potential Complications

The biotransformation process is not perfect. **Detoxification** occurs when biotransformation results in metabolites of lower toxicity. In many cases, however, the metabolites are more toxic than the parent substance, a process called **bioactivation**. Occasionally, biotransformation can produce an unusually reactive metabolite that may interact with cellular macromolecules like DNA. This can lead to very serious health effects such as cancer or birth defects.

An example is the biotransformation of vinyl chloride into vinyl chloride epoxide, which covalently binds to DNA and RNA, a step leading to cancer of the liver.

### Knowledge Check

The term "biotransformation" refers to:

- An increase in electrical charge in tissues produced by a biological transformer
- Chemical reactions in the body that create a new chemical from another chemical
- The transformation of one type of cell in a tissue to another type of cell

#### Answer

Chemical reactions in the body that create a new chemical from another chemical - **This is the correct answer.**  
 Biotransformation is the process whereby a substance is changed from one chemical to another (transformed) by a chemical reaction within the body.

Detoxification is a biotransformation process in which:

- Metabolites of lower toxicity are produced
- Metabolites of higher toxicity are produced

#### Answer

Metabolites of lower toxicity are produced - **This is the correct answer.**  
 When biotransformation results in metabolites of lower toxicity, the process is known as detoxification.

Bioactivation is a biotransformation process in which:

- Metabolites of lower toxicity are produced
- Metabolites of higher toxicity are produced

#### Answer

Metabolites of higher toxicity are produced - **This is the correct answer.**  
When biotransformation results in metabolites of higher toxicity, this is known as bioactivation.

This page titled [12.1: Introduction to Biotransformation](#) is shared under a [CC BY-NC 4.0](#) license and was authored, remixed, and/or curated by [ToxMSDT Online component](#) via [source content](#) that was edited to the style and standards of the LibreTexts platform.

## 12.2: Chemical Reactions

### Chemical Reactions

Chemical reactions are continually taking place in the body. They are a normal aspect of life, participating in the:

- Building up of new tissue.
- Tearing down of old tissue.
- Conversion of food to energy.
- Disposal of waste materials.
- Elimination of toxic xenobiotics.

Within the body is a magnificent assembly of chemical reactions, which is well orchestrated and called upon as needed. Most of these chemical reactions occur at significant rates only because specific proteins, known as enzymes, are present to catalyze them, that is, accelerate the reaction. A catalyst is a substance that can accelerate a chemical reaction of another substance without itself undergoing a permanent chemical change.

### Enzymes

**Enzymes** are the catalysts for nearly all biochemical reactions in the body. Without these enzymes, essential biotransformation reactions would take place slowly or not at all, causing major health problems.

### Did you know?

Phenylketonuria (PKU) is the genetic condition in which the enzyme that biotransforms phenylalanine to tyrosine (another amino acid) is defective. As the result, phenylalanine can build up in the body and cause severe mental retardation. Babies are routinely checked at birth for PKU. If they have PKU, they need to follow a special diet to restrict the intake of phenylalanine in infancy and childhood.

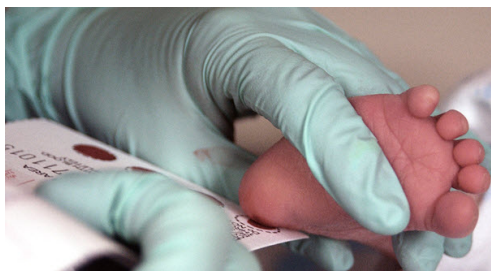
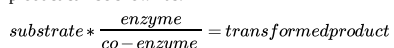

Figure 12.2.1. Phenylketonuria (PKU) testing in an infant  
(Image Source: [Wikimedia Commons](#), obtained under Public Domain license. Author: U.S. Air Force Photographic Archives)

These enzymatic reactions are not always simple biochemical reactions. Some enzymes require the presence of cofactors or coenzymes in addition to the **substrate** (the substance to be catalyzed) before their catalytic activity can be exerted. These co-factors exist as a normal component in most cells and are frequently involved in common reactions to convert nutrients into energy (vitamins are an example of co-factors). It is the drug or chemical transforming enzymes that hold the key to xenobiotic transformation. The relationship of substrate, enzyme, coenzyme, and transformed product can be shown as:



Most biotransforming enzymes are high molecular weight proteins, composed of chains of amino acids linked together by peptide bonds. A wide variety of biotransforming enzymes exist. Most enzymes will catalyze the reaction of only a few substrates, meaning that they have high specificity. Specificity is a function of the enzyme's structure and its catalytic sites. While an enzyme may encounter many different chemicals, only those chemicals (substrates) that fit within the enzyme's convoluted structure and spatial arrangement will be locked on and affected. This is sometimes referred to as the "lock and key" relationship.

As shown in Figure 12.2.2 when a substrate fits into the enzyme's structure, an enzyme-substrate complex can be formed. This allows the enzyme to react with the substrate with the result that two different products are formed. If the substrate does not fit into the enzyme ("incompatible"), no complex will be formed and thus no reaction can occur.

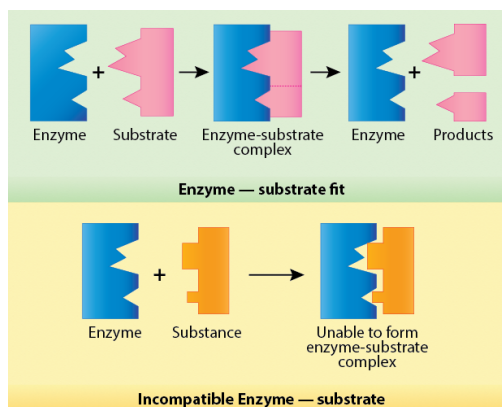

Figure 12.2.2 If the substrate does not fit into the enzyme, no complex will be formed and no reaction will occur.  
(Image Source: NLM)

## Enzyme Specificity

Enzymes range from having absolute specificity to broad and overlapping specificity. In general, there are three main types of specificity:

1. **Absolute** — the enzyme will catalyze only one reaction. Examples:
  - o Formaldehyde dehydrogenase catalyzes only the reaction for formaldehyde.
  - o Acetylcholinesterase biotransforms the neurotransmitting chemical, acetylcholine.
2. **Group** — the enzyme will act only on molecules that have specific functional groups, such as amino, phosphate, or methyl groups.
  - o For example, alcohol dehydrogenase can biotransform several different alcohols, including methanol and ethanol.
3. **Linkage** — the enzyme will act on a particular type of chemical bond regardless of the rest of the molecular structure.
  - o For example, N-oxidation can catalyze a reaction of a nitrogen bond, replacing the nitrogen with oxygen.

## Enzyme Naming Convention

The names assigned to enzymes may seem confusing at first. However, except for some of the originally studied enzymes (such as pepsin and trypsin), a convention has been adopted to name enzymes. Enzyme names end in "ase" and usually combine the substrate acted on and the type of reaction catalyzed.

For example, alcohol dehydrogenase is an enzyme that biotransforms alcohols by the removal of a hydrogen. The result is a completely different chemical, an aldehyde or ketone.

The biotransformation of ethyl alcohol to acetaldehyde is depicted in Figure 12.2.3

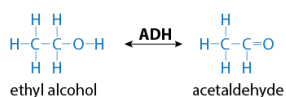

**ADH = alcohol dehydrogenase, a specific catalyzing enzyme**

Figure 12.2.3 Biotransformation of ethyl alcohol  
(Image Source: NLM)

### Beneficial or Harmful?

At this point in ToxTutor you likely see that the transformation of a specific xenobiotic can be either beneficial or harmful, and perhaps both depending on the dose and circumstances.

A good example is the biotransformation of acetaminophen (Tylenol®). When the prescribed doses are taken, the desired therapeutic response is observed with little or no toxicity. However, when excessive doses of acetaminophen are taken, hepatotoxicity can occur. This is because acetaminophen normally undergoes rapid biotransformation with the metabolites quickly eliminated in the urine and feces.

At high doses, the normal level of enzymes may be depleted and the acetaminophen is available to undergo the reaction by an additional biosynthetic pathway, which produces a reactive metabolite that is toxic to the liver. For this reason, a user of Tylenol® is warned not to take the prescribed dose more frequently than every 4–6 hours and not to consume more than four doses within a 24-hour period.

Biotransforming enzymes, like most other biochemicals, are available in a normal amount and in some situations can be "used up" at a rate that exceeds the body's ability to replenish them. This illustrates the frequently used phrase, the "dose makes the poison."



Figure 12.2.4 Generic acetaminophen tablets  
(Image Source: iStock Photos, ©)

## Biotransformation Reaction Phases

Biotransformation reactions are categorized not only by the nature of their reactions, for example, oxidation, but also by the normal sequence with which they tend to react with a xenobiotic. They are usually classified as Phase I and Phase II reactions.

**Phase I reactions** are generally reactions which modify the chemical by adding a functional structure. This allows the substance to "fit" into a second, or Phase II enzyme, so that it can become conjugated (joined together) with another substance.

**Phase II reactions** consist of those enzymatic reactions that conjugate the modified xenobiotic with another substance. The conjugated products are larger molecules than the substrate and generally polar in nature (water soluble). Thus, they can be readily excreted from the body. Conjugated compounds also have poor ability to cross cell membranes.

In some cases, the xenobiotic already has a functional group that can be conjugated and the xenobiotic can be biotransformed by a Phase II reaction without going through a Phase I reaction.

For example, phenol can be directly conjugated into a metabolite that can then be excreted. The biotransformation of benzene requires both Phase I and Phase II reactions. As illustrated in Figure 12.2.5 benzene is biotransformed initially to phenol by a Phase I reaction (oxidation). Phenol has a structure including a functional hydroxyl group that is then conjugated by a Phase II reaction (sulfation) to phenyl sulfate.

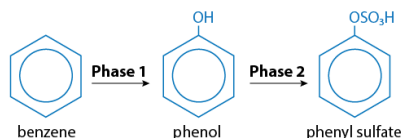

Figure 12.2.5 Biotransformation of benzene into phenol in Phase 1 (oxidation), which is then conjugated by a Phase 2 reaction (sulfation) to phenyl sulfate  
(Image Source: NLM)

Table 1 lists the major transformation reactions for xenobiotics broken into Phase I and Phase II reactions. These reactions are discussed in more detailed below.

Phase I	Phase II
Oxidation	Sulfate conjugation
Reduction	Glucuronide conjugation
Hydrolysis	Glutathione conjugation
Acetylation	Amino acid conjugation

Table 1. Phase I and II biotransformation reactions for xenobiotics

## Phase I Reactions

Phase I biotransformation reactions are simple reactions compared to Phase II reactions. In Phase I reactions, a small polar group (containing both positive and negative charges) is either exposed on the toxicant or added to the toxicant. The three main Phase I reactions are 1) oxidation; 2) reduction; and 3) hydrolysis.

### Oxidation

**Oxidation** is a chemical reaction in which a *substrate loses electrons*. There are a number of reactions that can achieve the removal of electrons from the substrate.

- The **addition of oxygen**, or **oxygenation**, was the first of these reactions discovered and thus the reaction was named oxidation. However, many of the oxidizing reactions do not involve oxygen.
- The simplest type of oxidation reaction is **dehydrogenation**, which is the removal of hydrogen from the molecule.
- Another example of oxidation is **electron transfer** that consists simply of the transfer of an electron from the substrate.

Figure 12.2.6 shows these types of oxidizing reactions.

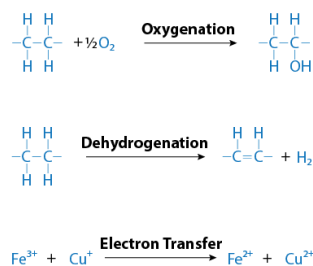

Figure 12.2.6 Three types of oxidation reactions  
(Image Source: NLM)

The specific oxidizing reactions and oxidizing enzymes are numerous and several textbooks are devoted to this subject. Most of the reactions are described by the name of the reaction or enzyme involved. Some of these oxidizing reactions include:

- Alcohol dehydrogenation
- Aldehyde dehydrogenation
- Alkyl/acyclic hydroxylation
- Aromatic hydroxylation
- Deamination
- Desulfuration
- N-dealkylation
- N-hydroxylation
- N-oxidation
- O-dealkylation
- Sulphoxidation

### Reduction

**Reduction** is a chemical reaction in which the *substrate gains electrons*. Reductions are most likely to occur with xenobiotics in which oxygen content is low. Reductions can occur across nitrogen-nitrogen double bonds (azo reduction) or on nitro groups (NO<sub>2</sub>). Frequently, the resulting amino compounds are oxidized which forms toxic metabolites. Some chemicals such as carbon tetrachloride can be reduced to free radicals, which are quite reactive with biological tissues. Thus, reduction reactions frequently result in activation of a xenobiotic rather than detoxification. An example of a reduction reaction in which the nitro group is reduced is illustrated in Figure 12.2.7.

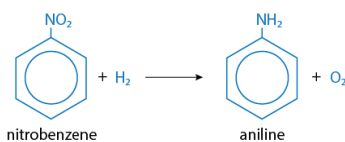

Figure above

There are fewer specific reduction reactions than oxidizing reactions. The nature of these reactions is also described by their name. Some reducing reactions include:

- Azo reduction
- Dehalogenation
- Disulfide reduction

- Nitro reduction
- N-oxide reduction
- Sulfoxide reduction

## Hydrolysis

**Hydrolysis** is a chemical reaction in which the *addition of water* splits the toxicant into two fragments or smaller molecules. The hydroxyl group (OH-) is incorporated into one fragment and the hydrogen atom is incorporated into the other. Larger chemicals such as esters, amines, hydrazines, and carbamates are generally biotransformed by hydrolysis. An example of hydrolysis is illustrated in the biotransformation of procaine (local anesthetic) which is hydrolyzed to two smaller chemicals (Figure 12.2.8).

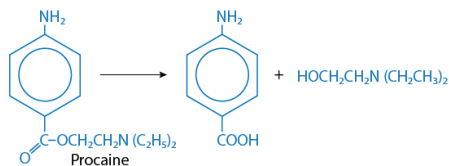

Figure 12.2.8 Hydrolysis of procaine

(Image Source: Adapted from Humboldt State University, Department of Chemistry. Author: Richard A. Paselk, Professor Emeritus. [View original image.](#))

Toxicants that have undergone Phase I biotransformation are converted to metabolites that are sufficiently ionized, or hydrophilic, to be either eliminated from the body without further biotransformation or converted to an intermediate metabolite that is ready for Phase II biotransformation. The intermediates from Phase I transformations may be pharmacologically more effective and in many cases more toxic than the parent xenobiotic.

## Phase II Reactions

A xenobiotic that has undergone a Phase I reaction is now a new intermediate metabolite that contains a reactive chemical group such as hydroxyl (-OH), amino (-NH<sub>2</sub>), and carboxyl (-COOH). Many of these intermediate metabolites do not possess sufficient hydrophilicity to permit elimination from the body. These metabolites must undergo additional biotransformation as a Phase II reaction.

Phase II reactions are conjugation reactions where a molecule normally present in the body is added to the reactive site of the Phase I metabolite. The result is a conjugated metabolite that is more water soluble than the original xenobiotic or Phase I metabolite. Usually, the Phase II metabolite is quite hydrophilic and can be readily eliminated from the body. The primary Phase II reactions are:

- Glucuronide conjugation – most important reaction (detailed below)
- Sulfate conjugation – important reaction (detailed below)
- Acetylation
- Amino acid conjugation
- Glutathione conjugation
- Methylation

## Glucuronide Conjugation

**Glucuronide conjugation** is one of the most important and common Phase II reactions. The glucuronic acid molecule is used in this reaction. It is derived from glucose, a common carbohydrate (sugar) that is the primary source of energy for cells. In this reaction, glucuronic acid is added directly to the toxicant or its phase I metabolite. The sites of glucuronidation reactions are substrates having an oxygen, nitrogen, or sulfur bond, which apply to a wide array of xenobiotics as well as endogenous substances, such as bilirubin, steroid hormones, and thyroid hormones.

Glucuronidation is a pathway that conjugates xenobiotics at a high capacity ("high-capacity pathway"). Glucuronide conjugation usually decreases toxicity although there are some notable exceptions, for example, where it can result in producing carcinogenic substances. The glucuronide conjugates are generally quite hydrophilic and are excreted by the kidney or bile, depending on the size of the conjugate. The glucuronide conjugation of aniline is illustrated in Figure 12.2.9.

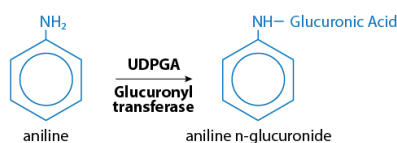

Figure 12.2.9 Glucuronide conjugation of aniline (which is used to make polyurethane, pharmaceuticals, and industrial chemicals)

(Image Source: NLM)

## Sulfate Conjugation

**Sulfate conjugation** is another important Phase II reaction that occurs with many xenobiotics. In general, sulfation decreases the toxicity of xenobiotics. Unlike glucuronic acid conjugates that are often eliminated in the bile, the highly polar sulfate conjugates are readily secreted in the urine. In general, sulfation is a low-capacity pathway for xenobiotic conjugation. Often glucuronidation or sulfation can conjugate the same xenobiotics.

### Knowledge Check

**1) The substances in the body that accelerate chemical reactions are known as:**

- Amino acids
- Enzymes
- Substrates

#### Answer

Enzymes - **This is the correct answer.**

Enzymes are proteins that catalyze nearly all biochemical reactions in the body.

**2) The convention used to name specific enzymes consists of combining:**

- a) The substrate name with the type of chemical reaction
- b) The target organ and the type of chemical reaction
- c) The substrate name with the form of toxicity

**Answer**

The substrate name with the type of chemical reaction - **This is the correct answer.**  
Enzyme names end in "ase" and usually combine the substrate acted on and the type of reaction catalyzed.

**3) Biotransformation reactions are classified as Phase I and Phase II. The basic difference is:**

- a) Phase I reactions conjugate a substrate whereas Phase II reactions oxidize the substance
- b) Phase I reactions generally add a functional structure whereas Phase II reactions conjugate the substance
- c) A Phase I reaction generally makes a substance more hydrophilic than a Phase II reaction

**Answer**

Phase I reactions generally add a functional structure whereas Phase II reactions conjugate the substance - **This is the correct answer.**  
Phase I reactions are generally reactions which modify the chemical by adding a functional structure. This allows the substance to "fit" into the Phase II enzyme so that it can become conjugated (joined together) with another substance. Phase II reactions consist of those enzymatic reactions that conjugate the modified xenobiotic with another substance.

**4) The difference between oxidation and reduction reactions is:**

- a) A substrate gains electrons from an oxidation reaction whereas it loses electrons by a reduction reaction
- b) Oxygen is removed from a substrate in oxidation and added in the reduction reaction
- c) A substrate loses electrons from an oxidation reaction whereas it gains electrons by a reduction reaction

**Answer**

A substrate loses electrons from an oxidation reaction whereas it gains electrons by a reduction reaction - **This is the correct answer.**  
Oxidation is a chemical reaction in which a substrate loses electrons. Reduction is a chemical reaction in which the substrate gains electrons.

**5) Which conjugation reaction is the most common in the biotransformation of xenobiotics?**

- a) Amino acid conjugation
- b) Glucuronide conjugation
- c) Methylation

**Answer**

Glucuronide conjugation - **This is the correct answer.**  
Glucuronide conjugation is one of the most important and common Phase II reactions. Glucuronidation is a high-capacity pathway for xenobiotic conjugation.

## 12.3: Biotransformation Sites

### Biotransformation Sites

Biotransforming enzymes are widely distributed throughout the body.

- The liver is the primary biotransforming organ due to its large size and high concentration of biotransforming enzymes.
- The kidneys and lungs are next with 10-30% of the liver's capacity.
- A low capacity exists in the skin, intestines, testes, and placenta.

### Primary Biotransformation Site: The Liver

Since the liver is the primary site for biotransformation, it is also potentially vulnerable to the toxic action of a xenobiotic that is activated to a more toxic compound.

Within the liver cell, the primary subcellular components containing the transforming enzymes are the **microsomes (small vesicles) of the endoplasmic reticulum** and the soluble fraction of the **cytoplasm (cytosol)**. The mitochondria, nuclei, and lysosomes contain a small level of transforming activity.

- Microsomal enzymes are associated with most Phase I reactions. Glucuronidation enzymes are also contained in microsomes.
- Cytosolic enzymes are non-membrane-bound and occur free within the cytoplasm. They are generally associated with Phase II reactions, although some oxidation and reduction enzymes are contained in the cytosol.
- The most important enzyme system involved in Phase I reactions are the **cytochromes P450**, also called the cytochrome P-450 system or the mixed function oxidase (MFO) system, but now mostly called CYP450 or CYPs by scientists and in research publications. It is found in microsomes and is responsible for oxidation reactions of a wide array of chemicals.

### Susceptibility of the Liver

The liver is particularly susceptible to damage by ingested toxicants because it biotransforms most xenobiotics and receives blood directly from the gastrointestinal tract. Blood leaving the gastrointestinal tract does not flow directly into the general circulatory system. Instead, it flows into the liver first via the portal vein. This process is known as the "first pass." Blood leaving the liver is eventually distributed to all other areas of the body; however, much of the absorbed xenobiotic has undergone detoxification or bioactivation. The liver may have removed most of the potentially toxic chemical. On the other hand, some toxic metabolites are highly concentrated in the liver.

#### Knowledge Check

#### 1) The organ that has the greatest ability to biotransform xenobiotics is the:

- a) Liver
- b) Pancreas
- c) Skin

#### Answer

Liver - **This is the correct answer.**

Biotransforming enzymes are widely distributed throughout the body. However, the liver has the largest concentration of all organs and thus has a very high capacity for biotransformation.

#### 2) The "first pass" phenomenon pertains to:

- a) The situation where xenobiotics that are absorbed from the GI tract first enter the circulating blood before going to the liver
- b) A condition where the liver first biotransforms a xenobiotic by Phase II reaction before it is biotransformed by a Phase I reaction
- c) An anatomical arrangement in which xenobiotics absorbed from the intestine go to the liver first rather than into the systemic circulation



**Answer**

An anatomical arrangement in which xenobiotics absorbed from the intestine go to the liver first rather than into the systemic circulation - **This is the correct answer.**

Blood leaving the gastrointestinal tract does not directly flow into the general circulatory system. Instead, it flows into the liver first via the portal vein. This is known as the "first pass" phenomena.

---

This page titled [12.3: Biotransformation Sites](#) is shared under a [CC BY-NC 4.0](#) license and was authored, remixed, and/or curated by [ToxMSDT Online component](#) via [source content](#) that was edited to the style and standards of the LibreTexts platform.

## 12.4: Modifiers of Biotransformation

---

### Modifiers of Biotransformation

The relative effectiveness of biotransformation depends on several factors that can inhibit or induce enzymes and dose levels. Factors include:

- Species
- Age
- Gender
- Genetic variability
- Nutrition
- Disease
- Exposure to other chemicals

### Species

It is well known that the capability to biotransform specific chemicals varies by **species**. These differences are termed selective toxicity, which refers to differences in toxicity between species similarly exposed. Research uses what is known about selective toxicity to develop chemicals that are effective but relatively safe in humans.

- For example, the pesticide malathion in mammals is biotransformed by hydrolysis to relatively safe metabolites, but in insects, it is oxidized to malaoxon, which is lethal to insects.

### Age and Gender

**Age** may affect the efficiency of biotransformation. In general, human fetuses and newborns have limited abilities to carry out xenobiotic biotransformations. This limitation is due to inherent deficiencies in many of the enzymes responsible for catalyzing Phase I and Phase II biotransformations. While the capacity for biotransformation fluctuates with age in adolescents, by early adulthood the enzyme activities have essentially stabilized. The aged also have decreased biotransformation capability.

**Gender** may influence the efficiency of biotransformation for specific xenobiotics. This is usually limited to hormone-related differences in the oxidizing cytochrome P-450 enzymes.

### Genetic Variability

**Genetic variability** in biotransforming capability accounts for most of the large variation among humans. In particular, human genetic differences influence the Phase II acetylation reaction. Some persons have rapid acetylation ("rapid acetylator") while others have a slow ability to carry out this reaction ("slow acetylator"). The most serious drug-related toxicity occurs in those who have slow acetylators, often referred to as "slow metabolizers." With slow acetylators, acetylation is so slow that blood or tissue levels of certain drugs (or Phase I metabolites) exceed their toxic threshold.

Table 12.4.1 includes examples of drugs that build up to toxic levels in slow metabolizers who have specific genetic-related defects in biotransforming enzymes.

Drug	Drug Category	Metabolic Defect	Toxic Effect
Isoniazid	antituberculosis drug	slow acetylation	nerve and liver damage
Hydralazine	antihypertensive drug	defect in mono-oxygenase enzyme	excessive fall in blood pressure
Dapsone	antibacterial agent	slow acetylation	systemic lupus erythematosus
Primaquine	antimalarial agent	defective G6PD	acute hemolytic anemia

Table 1. Examples of drugs that build to toxic levels in slow metabolizers with specific genetic-related defects in biotransforming enzymes

## Nutrition

Poor **nutrition** can have a detrimental effect on biotransforming ability. Poor nutrition relates to inadequate levels of protein, vitamins, and essential minerals. These deficiencies can decrease a person's ability to synthesize biotransforming enzymes. Many diseases can impair an individual's capacity to biotransform xenobiotics.

For example, hepatitis (a liver disease) is well known to reduce hepatic biotransformation to less than half of its normal capacity.

Prior or Simultaneous Exposure Prior or simultaneous exposure to xenobiotics can cause enzyme inhibition and enzyme induction.

In some situations, exposure to a substance will inhibit the biotransformation capacity for another chemical due to **inhibition of specific enzymes**. A major mechanism for the inhibition is competition between the two substances for the available oxidizing or conjugating enzymes. The presence of one substance uses up the enzyme needed to metabolize the second substance.

Exposure to Other Environmental Chemicals and Drugs Enzyme induction is a situation where prior exposure to certain environmental chemicals and drugs results in an enhanced capability for biotransforming a xenobiotic. The prior exposures stimulate the body to increase the production of some enzymes. This increased level of enzyme activity results in increased biotransformation of a chemical subsequently absorbed.

Examples of enzyme inducers include:

- Alcohol
- Isoniazid
- Polycyclic halogenated aromatic hydrocarbons (for example, dioxin)
- Phenobarbital
- Cigarette smoke

The most commonly induced enzyme reactions involve the cytochrome P450 enzymes.

**Dose level** can affect the nature of the biotransformation. In certain situations, the biotransformation may be quite different at high doses compared to low dose levels. This difference in biotransformation contributes to a dose threshold for toxicity. The existence of different biotransformation pathways can usually explain what causes this dose-related difference in biotransformation. At low doses, a xenobiotic may follow a biotransformation pathway that detoxifies the substance. However, if the amount of xenobiotic exceeds the specific enzyme capacity, the biotransformation pathway is saturated. In that case, it is possible that the level of parent toxin builds up. In other cases, the xenobiotic may enter a different biotransformation pathway that may end up producing a toxic metabolite.

An example of a dose-related difference in biotransformation occurs with acetaminophen (Tylenol®):

- At normal doses:
  - About 96% of acetaminophen is biotransformed to non-toxic metabolites by sulfate and glucuronide conjugation.
  - About 4% of the acetaminophen oxidizes to a toxic metabolite.
  - That toxic metabolite is conjugated with glutathione and excreted.
- At 7-10 times the recommended therapeutic level:
  - The sulfate and glucuronide conjugation pathways become saturated and more of the toxic metabolite is formed.
  - The glutathione in the liver may also be depleted so that the toxic metabolite is not detoxified and eliminated.
  - It can react with liver proteins and cause fatal liver damage.

 Knowledge Check

**1) Selective toxicity refers to a difference in the toxicity of a xenobiotic to different species. This selective toxicity can usually be attributed to differences in:**

- a) The ability to absorb the xenobiotic
- b) Organ systems between species
- c) Capability to biotransform the xenobiotic

**Answer**

Capability to biotransform the xenobiotic - **This is the correct answer.**

A difference between species in their capability to biotransform a specific chemical is normally the basis for a chemical's selective toxicity.

---

This page titled [12.4: Modifiers of Biotransformation](#) is shared under a [CC BY-NC 4.0](#) license and was authored, remixed, and/or curated by [ToxMSDT Online component](#) via [source content](#) that was edited to the style and standards of the LibreTexts platform.

## CHAPTER OVERVIEW

### Section 13: Excretion

## Learning Objectives

After completing this lesson, you will be able to:

- Define excretion.
- Identify the primary organ systems involved in excretion.
- Describe the basic mechanisms of excretion within each primary organ system involved.

## In this section...

Topics include:

- [13.1: Introduction to Secretion](#)
- [13.2: Urinary Excretion](#)
- [13.3: Fecal Excretion](#)
- [13.4: Exhaled Air](#)
- [13.5: Other Routes](#)

## Section 13: Key Points

## What We've Covered

This section made the following main points:

- Excretion, as used in ToxTutor, pertains to the elimination of a xenobiotic and its metabolites by specific excretory organs.
- The primary organ systems involved in excretion are the:
  - Urinary system, which involves:
    1. Filtration in the glomerulus.
    2. Secretion in the proximal tubule section of the nephron to transport certain molecules out of the blood and into the urine.
    3. Reabsorption in the proximal convoluted tubule of the nephron to reenter nearly all of the water, glucose, potassium, and amino acids lost during filtration back into the blood.
  - Gastrointestinal system, which occurs from two processes:
    1. Biliary excretion — generally active secretion by the liver into the bile and then into the intestinal tract, where it can be eliminated in the feces or reabsorbed.
    2. Intestinal excretion — an important elimination route only for xenobiotics that have slow biotransformation or slow urinary or biliary excretion.
  - Respiratory system, which is important for xenobiotics and metabolites that exist in a gaseous phase in the blood:
    - Excreted by passive diffusion from the blood into the alveolus.
- Minor routes of excretion occur including breast milk, sweat, saliva, tears, and semen.

---

This page titled [Section 13: Excretion](#) is shared under a [CC BY-NC 4.0](#) license and was authored, remixed, and/or curated by [ToxMSDT Online component](#) via [source content](#) that was edited to the style and standards of the LibreTexts platform.

## Introduction to Excretion

Elimination from the body is very important in determining the potential toxicity of a xenobiotic. When the body rapidly eliminates a toxic xenobiotic (or its metabolites), it is less likely that they will be able to concentrate in and damage critical cells. The terms excretion and elimination are frequently used to describe the same process in which a substance leaves the body. **Elimination** is sometimes used in a broader sense and includes the removal of the absorbed xenobiotic through metabolic pathways as well as through excretion. **Excretion**, as used here, pertains to the elimination of the xenobiotic and its metabolites by specific excretory organs.

Except for the lung, polar (hydrophilic) substances are more likely than lipid-soluble toxicants to be eliminated from the body. Chemicals must again pass through membranes in order to leave the body, and the same chemical and physical properties that governed passage across other membranes apply to excretory organs as well.

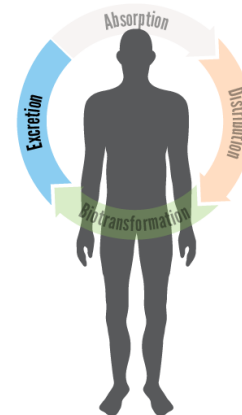

Figure 13.1.1. Processes of toxicokinetics  
(Image Source: Adapted from iStock Photos, ©)

### Primary Routes of Excretion

The body uses several routes to eliminate toxicants or their metabolites. The main routes of excretion are via urine, feces, and exhaled air. Thus, the primary organ systems involved in excretion are the:

- Urinary system
- Gastrointestinal system
- Respiratory system

A few other avenues for elimination exist but they are relatively unimportant, except in exceptional circumstances.

#### Knowledge Check

##### 1) The three major routes of excretion are:

- Gastrointestinal tract, sweat, and saliva
- Mother's milk, tears, and semen
- Urinary excretion, fecal excretion, and exhaled air

##### Answer

Urinary excretion, fecal excretion, and exhaled air - **This is the correct answer.**  
The main routes of excretion are via urine, feces, and exhaled air.

This page titled [13.1: Introduction to Secretion](#) is shared under a [CC BY-NC 4.0](#) license and was authored, remixed, and/or curated by [ToxMSDT Online component](#) via [source content](#) that was edited to the style and standards of the LibreTexts platform.

## 13.2: Urinary Excretion

# Urinary Excretion

The primary route in which the body eliminates substances is through the kidneys. The main function of the kidney is the excretion of body wastes and harmful chemicals into the urine. The functional unit of the kidney responsible for excretion is the nephron. Each kidney contains about one million nephrons. The nephron has three primary regions that function in the renal excretion process: the glomerulus, proximal tubule, and the distal tubule (Figure 13.2.2).

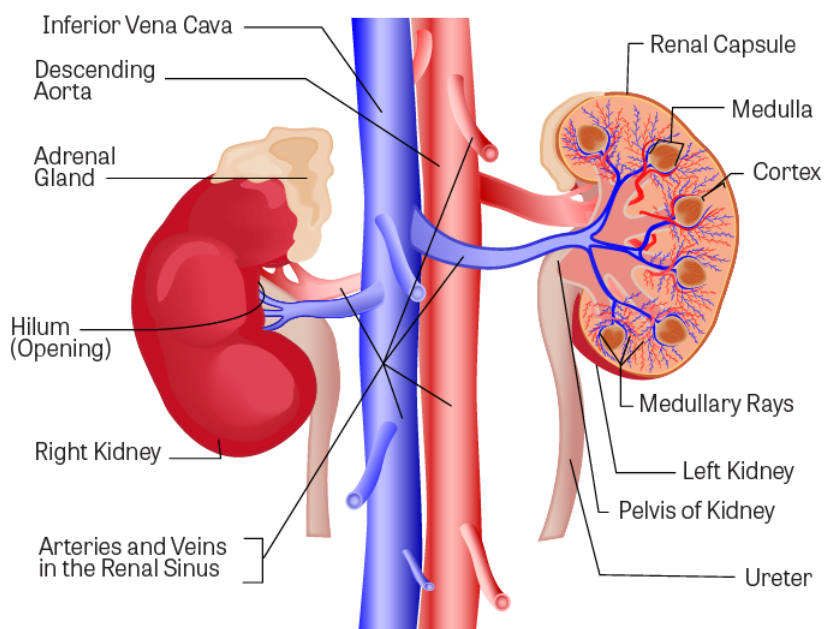

Figure 13.2.1 Components of the urinary system  
(Image Source: Adapted from iStock Photos, ©)

Three processes are involved in urinary excretion:

1. Filtration
2. Secretion
3. Reabsorption

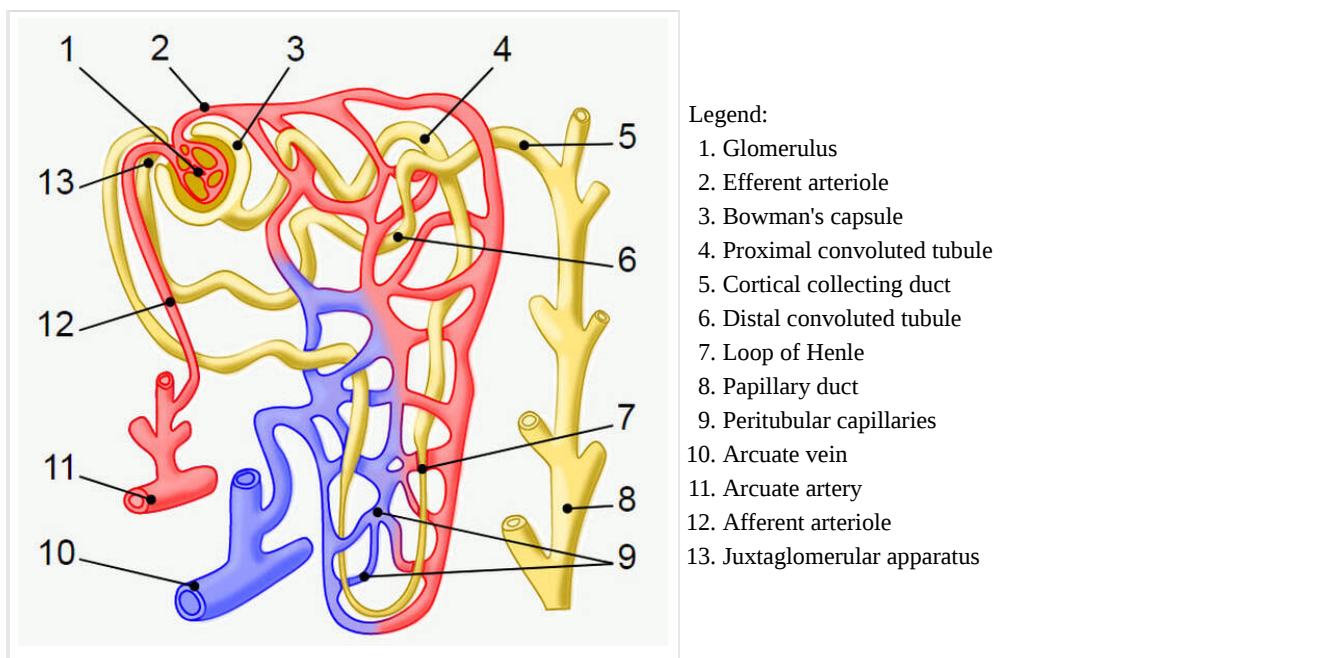

Figure 13.2.2 Nephron of the kidney

(Image Source: Adapted from Wikimedia Commons, obtained by Public Domain, Creative Commons CC0 1.0 Universal Public Domain Dedication.

[View original image.](#))

## Filtration

**Filtration** takes place in the glomerulus, which is the vascular beginning of the nephron. Approximately one-fourth of the blood flow from cardiac output circulates through the kidney, the greatest rate of blood flow for any organ. A considerable amount of the blood plasma filters through the glomerulus into the nephron tubule. This results from the large amount of blood flow through the glomerulus, the large pores (40 Angstrom [ $\text{\AA}$ ]) in the glomerular capillaries, and the hydrostatic pressure of the blood. Small molecules, including water, readily pass through the sieve-like filter into the nephron tubule. Both lipid soluble and polar substances will pass through the glomerulus into the tubule filtrate. The amount of filtrate is very large, about 45 gallons per day in an adult human. About 99% of the water-like filtrate, small molecules, and lipid-soluble substances, are reabsorbed downstream in the nephron tubule. This means that the amount of urine eliminated is only about one percent of the amount of fluid filtrated through the glomeruli into the renal tubules.

Molecules with molecular weights greater than 60,000 (which include large protein molecules and blood cells) cannot pass through the capillary pores and remain in the blood. If urine contains albumin or blood cells, it indicates that the glomeruli have been damaged. Binding to plasma proteins will influence urinary excretion. Polar substances usually do not bind with the plasma proteins and thus can be filtered out of the blood into the tubule filtrate. In contrast, substances extensively bound to plasma proteins remain in the blood.

## Secretion

**Secretion**, which occurs in the proximal tubule section of the nephron, is responsible for the transport of certain molecules out of the blood and into the urine. Secreted substances include potassium ions, hydrogen ions, and some xenobiotics. Secretion occurs by active transport mechanisms that are capable of differentiating among compounds based on polarity. Two systems exist, one that transports **weak acids** (such as many conjugated drugs and penicillins) and the other that transports **basic substances** (such as histamine and choline).



## Reabsorption

**Reabsorption** takes place mainly in the proximal convoluted tubule of the nephron. Nearly all of the water, glucose, potassium, and amino acids lost during glomerular filtration reenter the blood from the renal tubules. Reabsorption occurs primarily by passive transfer based on a concentration gradient, moving from a high concentration in the proximal tubule to the lower concentration in the capillaries surrounding the tubule (Figures 4-6).

A factor that greatly affects reabsorption and urinary excretion is the pH of the urine. This is especially the case with weak electrolytes. If the urine is alkaline, weak acids are more ionized and excretion is increased. Weak acids (such as glucuronide and sulfate conjugates) are less ionized if the urine is acidic and undergo reabsorption and renal excretion is reduced. Since the urinary pH varies in humans, the urinary excretion rates of weak electrolytes also vary.

- Examples are phenobarbital (an acidic drug) which is ionized in alkaline urine and amphetamine (a basic drug) which is ionized in acidic urine. Treatment of barbiturate poisoning (such as an overdose of phenobarbital) may include changing the pH of the urine to facilitate excretion.
- Diet may have an influence on urinary pH and thus the elimination of some toxicants. For example, a high-protein diet results in acidic urine.

The physical properties (primarily molecular size) and polarity of a substance in the urinary filtrate greatly affect its ultimate elimination by the kidney. Small toxicants (both polar and lipid-soluble) are filtered with ease by the glomerulus. In some cases, large molecules (including some that are protein-bound) may be secreted (by passive transfer) from the blood across capillary endothelial cells and nephron tubule membranes to enter the urine. The major difference in ultimate fate is governed by a substance's polarity. Those substances that are ionized remain in the urine and leave the body. Lipid-soluble toxicants can be reabsorbed and re-enter the blood circulation, which lengthens their half-life in the body and potential for toxicity.

Kidneys, which have been damaged by toxins, infectious diseases, or because of age, have diminished ability to eliminate toxicants thus making those individuals more susceptible to toxins that enter the body. The presence of albumin in the urine indicates that the glomerulus filtering system is damaged, letting large molecules pass through. The presence of glucose in the urine is an indication that tubular reabsorption has been impaired.

### Knowledge Check

#### 1) The reason that much of the blood plasma filters into the renal tubule is due to:

- a) The large amount of blood, under relatively high pressure, that flows through kidney glomerulae whose capillaries have large pores
- b) Its high lipid content
- c) The high binding content of plasma

#### Answer

The large amount of blood, under relatively high pressure, that flows through kidney glomerulae whose capillaries have large pores - **This is the correct answer.**

A considerable amount of the blood plasma filters through the glomerulus into the nephron tubule. This results from the large amount of blood flow through the glomerulus, the large pores (40 Angstrom [Å]) in the glomerular capillaries, and the hydrostatic pressure of the blood.

#### 2) In which area of the nephron does active secretion take place?

- a) The collecting duct of the nephron
- b) The proximal tubule of the nephron
- c) The glomerulus of the nephron

#### Answer

The proximal tubule of the nephron - **This is the correct answer.**

Secretion occurs in the proximal tubule section of the nephron and is responsible for the transport of certain molecules out

of the blood and into the urine.

**3) Most of the material filtered through the glomerulus is reabsorbed in the proximal convoluted tubule of the nephron. The primary property of a xenobiotic that determines whether it will be reabsorbed is:**

- a) Protein binding
- b) Molecular size
- c) Polarity

**Answer**

Polarity - **This is the correct answer.**

The ultimate fate of a substance filtered into the renal tubule is governed by its polarity. Those substances that are ionized remain in the urine and leave the body.

This page titled [13.2: Urinary Excretion](#) is shared under a [CC BY-NC 4.0](#) license and was authored, remixed, and/or curated by [ToxMSDT Online component](#) via [source content](#) that was edited to the style and standards of the LibreTexts platform.

## 13.3: Fecal Excretion

---

### Fecal Excretion

Elimination of toxicants in the feces occurs from two processes:

1. Excretion in bile, which then enters the intestine ("biliary excretion").
2. Direct excretion into the lumen of the gastrointestinal tract ("intestinal excretion").

### Biliary Excretion

The **biliary route** is an important mechanism for fecal excretion of xenobiotics and is even more important for the excretion of their metabolites. This route generally involves active secretion rather than passive diffusion. Specific transport systems appear to exist for certain types of substances, for example, organic bases, organic acids, and neutral substances. Some heavy metals are excreted in the bile, for example, arsenic, lead, and mercury. However, the most likely substances to be excreted via the bile are comparatively large, ionized molecules, such as those having a large molecular weight (conjugates greater than 300).

Once a substance has been excreted by the liver into the bile, and then into the intestinal tract, it can be eliminated from the body in the feces, or it may be reabsorbed. Since most of the substances excreted in the bile are water soluble, they are not likely to be reabsorbed as such. However, enzymes in the intestinal flora are capable of hydrolyzing some glucuronide and sulfate conjugates, which can release the less polar compounds that may then be reabsorbed. This process of excretion into the intestinal tract via the bile and reabsorption and return to the liver by the portal circulation is known as the **enterohepatic circulation** (Figure 1).

Enterohepatic circulation prolongs the life of the xenobiotic in the body. In some cases, the metabolite is more toxic than the excreted conjugate. Continuous enterohepatic recycling can occur and lead to very long half-lives of some substances. For this reason, drugs may be given orally to bind substances excreted in the bile.

- For example, a resin can be taken orally to bind with dimethylmercury, which had been secreted in the bile. The binding of the resin to dimethylmercury prevents its reabsorption and further toxicity.

Changes in the production and flow of bile into the liver affect the efficiency of biliary excretion.

- Liver disease usually causes a decrease in bile flow.
- Some drugs such as phenobarbital can produce an increase in bile flow rate. Administration of phenobarbital has been shown to enhance the excretion of methylmercury by this mechanism.

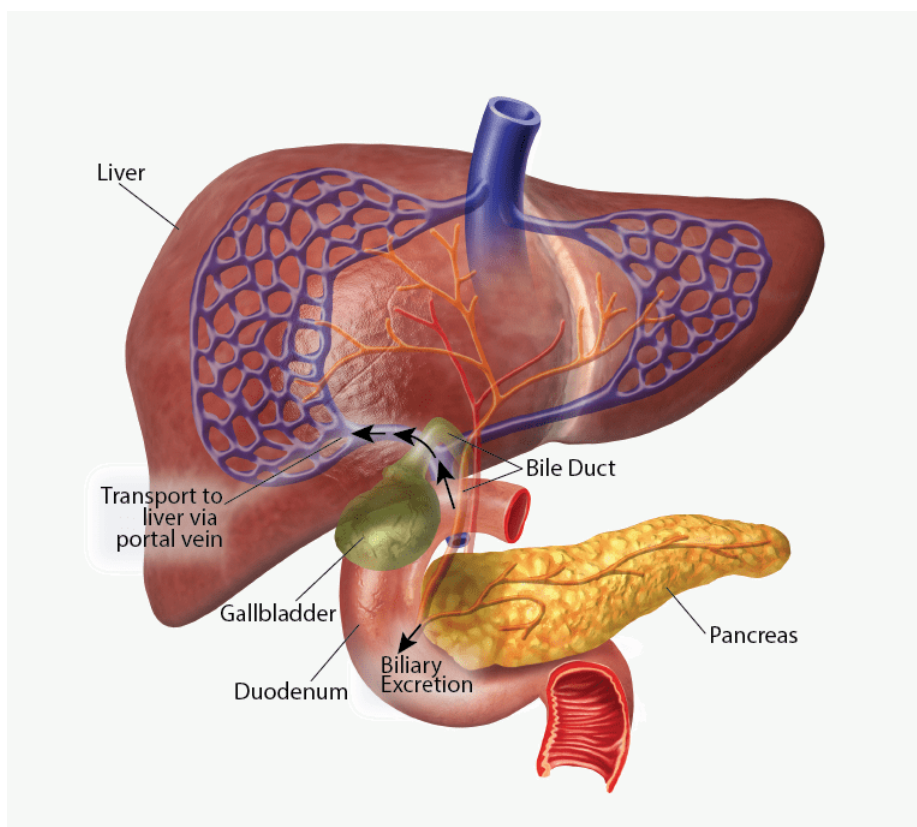

Figure 13.3.1 Biliary excretion and enterohepatic circulation  
(Image Source: Adapted from iStock Photos, ©)

## Intestinal Excretion

Another way that xenobiotics can be eliminated via the feces is by direct **intestinal excretion**. While this is not a major route of elimination, a large number of substances can be excreted into the intestinal tract and eliminated via feces. Some substances, especially those that are poorly ionized in plasma (such as weak bases), may passively diffuse through the walls of the capillaries, through the intestinal submucosa, and into the intestinal lumen to be eliminated in feces.

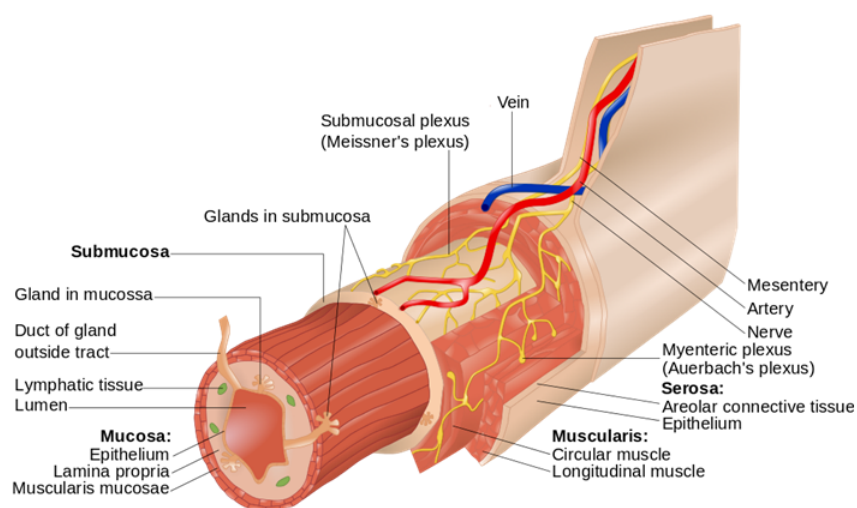

Figure 13.3.2 Layers of the Alimentary Canal

(Image Source: Wikimedia Commons, obtained under Creative Commons Attribution-Share Alike 3.0 Unported license. Author: [Goran tek-en](#). [View original image.](#))

Intestinal excretion is a relatively slow process and therefore, it is an important elimination route only for those xenobiotics that have slow biotransformation, or slow urinary or biliary excretion. Increasing the lipid content of the intestinal tract can enhance intestinal excretion of some lipophilic substances. For this reason, mineral oil (liquid paraffin, derived from petroleum) is sometimes added to the diet to help eliminate toxic substances, which are known to be excreted directly into the intestinal tract.

#### Knowledge Check

### 1) Substances excreted in the bile are primarily:

- a) Small, lipid soluble molecules
- b) Comparatively large, ionized molecules
- c) Large, lipid soluble molecules

#### Answer

Comparatively large, ionized molecules - **This is the correct answer.**

The most likely substances to be excreted via the bile are comparatively large, ionized molecules, such as large molecular weight (greater than 300) conjugates.

### 2) Many substances excreted in bile undergo enterohepatic circulation, which involves:

- a) Excretion of substances into the circulating system rather than into the intestine
- b) Excretion into the intestinal tract and reabsorption and return to the liver by the portal circulation
- c) The recycling of xenobiotics between the liver and gall bladder

#### Answer

Excretion into the intestinal tract and reabsorption and return to the liver by the portal circulation - **This is the correct answer.**

The process of excretion into the intestinal tract via the bile and reabsorption and return to the liver by the portal circulation is known as the enterohepatic circulation. The effect of this enterohepatic circulation is to prolong the life of the xenobiotic in the body.

This page titled [13.3: Fecal Excretion](#) is shared under a [CC BY-NC 4.0](#) license and was authored, remixed, and/or curated by [ToxMSDT Online component](#) via [source content](#) that was edited to the style and standards of the LibreTexts platform.

## 13.4: Exhaled Air

### Exhaled Air

The lungs are an important route of excretion for xenobiotics (and metabolites) that exist in a gaseous phase in the blood.

#### Passive Diffusion

Blood gases are excreted by passive diffusion from the blood into the alveolus, following a concentration gradient. This type of excretion occurs when the concentration of the xenobiotic dissolved in capillary blood is greater than the concentration of the substance in the alveolar air. Gases with a low solubility in blood are more rapidly eliminated than those gases with a high solubility. Volatile liquids dissolved in the blood are also readily excreted via the expired air.

For example, breathalyzer devices can measure blood alcohol concentration because as alcohol in the blood moves across the alveoli the alcohol in the blood evaporates and is exhaled. The concentration of alcohol in the exhaled air relates to the level of alcohol in the blood.

#### Impact of Vapor Pressure

The amount of a liquid excreted by the lungs is proportional to its vapor pressure. Exhalation is an exception to most other routes of excretion in that it can be a very efficient route of excretion for lipid soluble substances. This is due to the very close proximity of capillary and alveolar membranes, which are thin and allow for the normal gaseous exchange that occurs in breathing.

#### Knowledge Check

##### 1) Xenobiotics are eliminated in exhaled air by:

- a) Passive diffusion
- b) Active transport
- c) Facilitated transport

##### Answer

Passive diffusion - **This is the correct answer.**

Blood gases are excreted by passive diffusion from the blood into the alveolus, following a concentration gradient. This occurs when the concentration of the xenobiotic dissolved in capillary blood is greater than the concentration of the substance in the alveolar air.

This page titled [13.4: Exhaled Air](#) is shared under a [CC BY-NC 4.0](#) license and was authored, remixed, and/or curated by [ToxMSDT Online component](#) via [source content](#) that was edited to the style and standards of the LibreTexts platform.

## 13.5: Other Routes

### Other Routes of Excretion

Several minor routes of excretion occur including mother's milk, sweat, saliva, tears, and semen.

### Excretion into Breast Milk

Excretion into milk can be important since toxicants can be passed with milk to the nursing offspring. In addition, toxic substances can pass from cow's milk to people. Toxic substances are excreted into milk by simple diffusion. Both basic substances and lipid soluble compounds can be **excreted into milk** (The National Library of Medicine's [LactMed](#) is a resource for information on drugs, dietary supplements, and herbs that pass into breast milk.).

Basic substances can be concentrated in milk since milk is more acidic (pH approximately 6.5) than blood plasma. Since milk contains 3–4% lipids, lipid soluble xenobiotics can diffuse along with fats from plasma into the mammary gland and thus can be present in mother's milk. Substances such as lead, mercury, Bisphenol A (BPA), and phthalates that are chemically similar to calcium can also be excreted into milk along with calcium.

### Did you know?

Volatile organic compounds (VOCs) found in indoor air can also be found in breast milk.

Examples include MTBE (methyl tert-butyl ether), chloroform, benzene, and toluene. For benzene, toluene, and MTBE, the levels in breast milk followed the indoor air concentrations. However, the infant average daily dose by inhalation exceeded ingestion rates by 25-to-135 fold. Thus, the amount of VOC exposure from indoor air in nonsmoking households is much greater than the VOC exposure from breast milk. Strategies to lessen infant VOC exposure should focus on improving indoor air quality.

## Excretion into All Other Body Secretions or Tissues

Excretion of xenobiotics in **all other body secretions or tissues** (including the saliva, sweat, tears, hair, and skin) are of only minor importance. Under conditions of great sweat production, excretion in sweat may reach a significant degree. Some metals, including cadmium, copper, iron, lead, nickel, and zinc, may be eliminated in sweat to some extent. Xenobiotics that passively diffuse into saliva may be swallowed and absorbed by the gastrointestinal system. The excretion of some substances into saliva is responsible for the unpleasant taste that sometimes occurs with time after exposure to a substance.

#### Knowledge Check

#### 1) The following are minor routes of excretion:

- a) Sweat and saliva
- b) Urinary excretion, fecal excretion, and exhaled air

#### Answer

Sweat and saliva - **This is the correct answer.**

Several minor routes of excretion exist, primarily via mother's milk, sweat, saliva, tears, and semen. The main routes of excretion are via urine, feces, and exhaled air.

This page titled [13.5: Other Routes](#) is shared under a [CC BY-NC 4.0](#) license and was authored, remixed, and/or curated by [ToxMSDT Online component](#) via [source content](#) that was edited to the style and standards of the LibreTexts platform.

## CHAPTER OVERVIEW

### Section 14: Cellular Toxicology

## Learning Objectives

After completing this lesson, you will be able to:

- Explain cellular adaptation.
- Identify four possible endpoints to toxic damage to cells and tissues.
- Define commonly used cancer terms.
- Describe the phases of and genetic activity associated with carcinogenesis.
- Identify mechanisms and potential outcomes of neurotoxicity.

## In this section...

Topics include:

[14.1: Adaptation](#)

[14.2: Cell Damage and Tissue Repair](#)

[14.3: Cancer](#)

[14.4: Neurotoxicity](#)

## Section 14: Key Points

## What We've Covered

This section made the following main points:

- To maintain homeostasis, cells and tissues undergo:
  - Physiological adaptation, which is beneficial in nature — for example, increased skeletal muscle cells in athletes.
  - Pathological adaptation, which is detrimental — for example, cellular changes in people who smoke cigarettes.
- Specific types of adaptation include:
  - Atrophy — a decrease in the size of cells.
  - Hypertrophy — an increase in the size of individual cells.
  - Hyperplasia — an increase in the number of cells in a tissue.
  - Metaplasia — the conversion from one type of mature cell to another type.
  - Dysplasia — abnormal cell changes or deranged cell growth.
  - Anaplasia — cells that are undifferentiated.
  - Neoplasia — new growth of tissue.
- Most toxic effects, especially due to xenobiotics, are due to specific biochemical interactions without causing recognizable damage to a cell or its organelles. Cellular or biochemical toxicity leads to:
  - The tissue being completely repaired and returned to normal.
  - The tissue being incompletely repaired but capable of functioning with reduced capacity.
  - Death of the organism or complete loss of a tissue or organ.
  - Neoplasm or cancers.
- Tumors are either:



- Benign — similar to the cell of origin, slow-growing, and usually without systemic effects.
- Malignant — dissimilar from the cell of origin, rapid-growing, and commonly with systemic effects and life-threatening. Most malignant tumors are either:
  - Carcinomas — arising in epithelium, the most common form of cancer, usually spread in the lymphatic system.
  - Sarcomas — arising in connective or muscle tissue, usually spread by the blood stream.
- Carcinogenesis is a multi-step, multi-factorial genetic disease consisting of at least three main phases:
  1. Initiation — irreversible alteration of the DNA (mutation) of a normal cell.
  2. Promotion/Conversion — promoters enhance further development of the initiated cells, often influencing further expression of the mutated DNA such that the initiated cell proliferates and progresses further.
  3. Progression — development of the initiated cell into a biologically malignant cell population, often with metastasis to other areas of the body.
- Regulatory genes control the activity of structural genes and direct the proliferation process of the cell. Regulatory genes that play roles in carcinogenesis include:
  - Proto-oncogenes — normal cellular genes that encode and instruct the production of regulatory proteins and growth factors within a cell or its membrane.
  - Oncogenes — altered or misdirected proto-oncogenes with the ability to direct the production of proteins within the cell that change or transform the normal cell into a neoplastic cell.
  - Tumor suppressor genes (anti-oncogenes) — present in normal cells and counteract and change the proto-oncogenes and altered proteins, preventing a cell with damaged DNA from proliferating and evolving into an uncontrolled growth.
    - The p53 gene normally halts cell division, stimulates repair enzymes, and if necessary, commands the mutated cell to self-destruct
    - p53 is the most frequently altered in human tumors and is incapable of its defense mechanisms
- Toxic damage to the nervous system is divided into three categories:
  1. Damage to sensory receptors and sensory neurons impacting the sensory functions.
  2. Damage to motor neurons causing muscular weakness and paralysis.
  3. Interneuronal damage causing learning deficiencies, memory loss, incoordination, and emotional conditions.

---

This page titled [Section 14: Cellular Toxicology](#) is shared under a [CC BY-NC 4.0](#) license and was authored, remixed, and/or curated by [ToxMSDT Online component](#) via [source content](#) that was edited to the style and standards of the LibreTexts platform.

## 14.1: Adaptation

This section discusses cellular effects yet cell and chemical effects cannot be conveniently separated because cells are constructed of a variety of chemicals of diverse types. Specific intracellular chemical changes may occur as changes in the cell and may affect either its appearance or function. The actual mechanisms leading to cell damage are usually biochemical in nature.

### Adaptation Explained

To maintain homeostasis, cells and tissues:

- "Cope" with new demands placed on them by constantly adapting to changes in the tissue environment.
- Are usually capable of an amazing degree of cellular adaptability.
- Adapt in a way that may be beneficial in nature (physiological) or detrimental (pathological).

Examples of **physiological adaptation** are:

- An increase in skeletal muscle cells in athletes due to exercise and increased metabolic demand.
- The increase in number and size of epithelial cells in breasts of women resulting from endocrine stimulation during pregnancy.

When these cells or tissues are damaged, the body attempts to adapt and repair or limit the harmful effects. Often the adaptive changes result in cells or organs that cannot function normally. This imperfect adaptation is a pathological change.

Examples of **pathological adaptations** are:

- Cellular changes in people who smoke cigarettes: The ciliated columnar epithelium changes to non-ciliated squamous epithelium in the trachea and bronchi of cigarette smokers. The replacement of squamous epithelium can better withstand the irritation of the cigarette smoke. However, the loss of cilia and mucous secretions of columnar epithelium diminish the tracheobronchial defense mechanisms.
- Replacement of normal liver cells by fibrotic cells in chronic alcoholics (known as cirrhosis of the liver): A severely cirrhotic liver is incapable of normal metabolism, maintenance of nutrition, and detoxification of xenobiotics.

If the change is minor, cellular adaptation may result and the cells return to normal. When damage is very severe, the result may be cell death or permanent functional incapacitation.

Cellular adaptation to toxic agents includes three basic types:

1. Increase in cell activity.
2. Decrease in cell activity.
3. Alteration in cell morphology (structure and appearance) or cell function.

## Specific Types of Cellular Adaptations

### Atrophy

**Atrophy** is a **decrease in the size of cells**. If a sufficient number of cells are involved, the tissue or organ may also decrease in size. When cells atrophy, they have:

- Reduced oxygen needs.
- Reduced protein synthesis.
- Decreased number and size of the organelles.

The most common causes of atrophy are reduced use of the cells, lack of hormonal or nerve stimulation, decrease in nutrition, reduced blood flow to the tissue, and natural aging.

- An example of atrophy is the decrease in the size of muscles and muscle cells in persons whose legs are paralyzed, in a cast, or infrequently used as when a patient is on bedrest.

### Hypertrophy

**Hypertrophy** is an **increase in the size of individual cells**. This frequently results in an increase in the size of a tissue or organ. When cells hypertrophy, components of the cell increase in numbers with increased functional capacity to meeting increased cell

needs. Hypertrophy generally occurs in situations where the organ or tissue cannot adapt to an increased demand by formation of more cells. This is commonly seen in cardiac and skeletal muscle cells, which do not divide to form more cells. Common causes for hypertrophy are increased work or stress placed on an organ or hormonal stimulation.

- An example of hypertrophy is the compensatory increase in the size of cells in one kidney after the other kidney has been removed or is in a diseased state.

## Hyperplasia

**Hyperplasia** is an **increase in the number of cells in a tissue**. This generally results in an enlargement of tissue mass and organ size. It occurs *only* in tissues capable of mitosis such as the epithelium of skin, intestine, and glands. Some cells do not divide and thus cannot undergo hyperplasia, for example, nerve and muscle cells. Hyperplasia is often a compensatory measure to meet an increase in body demands. Hyperplasia is a frequent response to toxic agents and damage to tissues such as wounds or trauma. In wound healing, hyperplasia of connective tissue (for example, fibroblasts and blood vessels) contributes to the wound repair. In many cases, when the toxic stress is removed, the tissue returns to normal. Hyperplasia may result from hormonal stimulation, for example, breast and uterine enlargement due to increased estrogen production during pregnancy.

## Metaplasia

**Metaplasia** is the **conversion** from one type of mature cell to another type of mature cell. It is a cellular replacement process. A metaplastic response often occurs with chronic irritation and inflammation. This results in a tissue more resistant to the external stress since the replacement cells are capable of survival under circumstances in which the original cell type could not survive. However, the cellular changes usually result in a loss of function, which was performed by the original cells that were lost and replaced.

Examples of metaplasia are:

- The common condition in which a person suffers from chronic reflux of acid from the stomach into the esophagus (Gastroesophageal Reflux Disease). The normal esophageal cells (squamous epithelium) are sensitive to the refluxed acid and die. They are replaced with the columnar cells of the stomach that are resistant to the stomach's acidity. This pathological condition is known as "Barrett's Esophagus."
- The change in the cells of the trachea and bronchi of chronic cigarette smokers from ciliated columnar epithelium to non-ciliated stratified squamous epithelium. The sites of metaplasia frequently are also sites for neoplastic transformations. The replacement cells lack the defense mechanism performed by the cilia in moving particles up and out of the trachea.
- With cirrhosis of the liver, which is a common condition of chronic alcoholics, the normal functional hepatic cells are replaced by nonfunctional fibrous tissue.

## Dysplasia

**Dysplasia** is a condition of **abnormal cell changes or deranged cell growth** in which the cells are structurally changed in size, shape, and appearance from the original cell type. Cellular organelles also become abnormal. A common feature of dysplastic cells is that the nuclei are larger than normal and the dysplastic cells have a mitotic rate higher than the predecessor normal cells. Causes of dysplasia include chronic irritation and infection. In many cases, the dysplasia can be reversed if the stress is removed and normal cells return. In other cases, dysplasia may be permanent or represent a precancerous change.

- An example of dysplasia is the atypical cervical cells that precede cervical cancer. Routine examination of cervical cells is a routine screening test for dysplasia and possible early stage cervical cancer (Papanicolaou test).
- Cancer occurs at the site of Barrett's syndrome and in the bronchi of chronic smokers (bronchogenic squamous cell carcinoma).

## Anaplasia

**Anaplasia** refers to **cells that are undifferentiated**. They have irregular nuclei and cell structure with numerous mitotic figures. Anaplasia is frequently associated with malignancies and serves as one criterion for grading the aggressiveness of a cancer. For example, an anaplastic carcinoma is one in which the cell appearance has changed from the highly differentiated cell of origin to a cell type lacking the normal characteristics of the original cell. In general, anaplastic cells have lost the normal cellular controls, which regulate division and differentiation.

## Neoplasia

**Neoplasia** is a **new growth of tissue** and is commonly referred to as a tumor. There are two types of neoplasia: benign and malignant. Malignant neoplasia are cancers. Since cancer is such an important and complex medical problem, a [separate section](#) is devoted to cancer.

## Interactions

**Interactions between two or more toxic agents** can produce damage by chemical-chemical interactions, chemical-receptor interactions, or by modification, by a first agent, of the cell and tissue response to a second agent. Interactions may occur by simultaneous exposure and if exposure to the two agents is separated in time.

*Chemical-chemical interactions* have been mostly studied in the toxicology of air pollutants, where it was shown that the untoward effect of certain oxidants may be enhanced in the presence of other aerosols.

Interactions at the *receptor site* have been found in isolated perfused lung experiments. Oxygen tolerance may be an example, when pre-exposure to one concentration of oxygen mitigates later exposure to 100% oxygen by modifying cellular and enzymatic composition of the lung.

Damage of the alveolar zone by the antioxidant butylated hydroxytoluene (BHT) in mice can be greatly enhanced by *subsequent exposure* to oxygen concentration which, otherwise, would have little if any demonstrable effect.

The *synergistic interaction* between BHT and oxygen in mice results in interstitial pulmonary fibrosis. Acute or chronic lung disease may then be caused not only by one agent, but also in many instances by the interaction of several agents.

### Knowledge Check

**1) An increase in skeletal muscle cells in athletes due to exercise and increased metabolic demand is an example of:**

- a) Pathological adaptation
- b) Physiological adaptation

**Answer**

Physiological adaptation - **This is the correct answer.**

The increase in skeletal muscle cells in athletes due to exercise and increased metabolic demand is an example of physiological adaptation since the increased muscle is beneficial rather than harmful.

**2) A cellular response in which there is an increase in the number of cells in a tissue is known as:**

- a) Atrophy
- b) Hypertrophy
- c) Hyperplasia
- d) Metaplasia

**Answer**

Hyperplasia - **This is the correct answer.**

Hyperplasia is an increase in the number of cells in a tissue.

**3) A condition of abnormal cell changes or deranged cell growth in which the cells are structurally changed in size, shape, and appearance from the original cell type is**

**known as:**

- a) Dysplasia
- b) Anaplasia
- c) Neoplasia

**Answer**

Dysplasia - **This is the correct answer.**

Dysplasia is a condition of abnormal cell changes or deranged cell growth in which the cells are structurally changed in size, shape, and appearance from the original cell type.

This page titled [14.1: Adaptation](#) is shared under a [CC BY-NC 4.0](#) license and was authored, remixed, and/or curated by [ToxMSDT Online component](#) via [source content](#) that was edited to the style and standards of the LibreTexts platform.

## 14.2: Cell Damage and Tissue Repair

### Cell Damage and Tissue Repair

Toxic damage to cells can cause individual cell death and if sufficient cells are lost, the result can be tissue or organ failure, ultimately leading to death of the organism. It is nearly impossible to separate a discussion of cellular toxicity and biochemical toxicity. Most observable cellular changes and cell death are due to specific biochemical changes within the cell or in the surrounding tissue. However, there are a few situations where a toxic chemical or physical agent can cause cell damage without actually affecting a specific chemical in the cell or its membrane. Physical agents such as heat and radiation may damage a cell by coagulating their contents (similar to cooking). In this case, there are no specific chemical interactions. Impaired nutrient supply (such as glucose and oxygen) may deprive the cell of essential materials needed for survival.

### Toxic Effects

The majority of toxic effects, especially due to xenobiotics, are due to specific biochemical interactions without causing recognizable damage to a cell or its organelles.

Examples of these toxic effects include:

- Interference with a chemical that transmits a message across a neural synapse such as the inhibition of the enzyme acetylcholinesterase by organophosphate pesticides.
- When one toxic chemical inhibits or replaces another essential chemical such as the replacement of oxygen on the hemoglobin molecule with carbon monoxide.

The human body is extremely complex. In addition to over 200 different cell types and about as many types of tissues, there are literally thousands of different biochemicals, which may act alone or in concert to keep the body functions operating correctly. To illustrate the cell's structures and functions and the chemical toxicity of all tissues and organs would be impossible in this brief tutorial. This section presents only a general overview of toxic effects along with some specific types of toxicity that include cancer and neurotoxicity.

### Capacity for Repair

Some tissues have a great capacity for repair, such as most epithelial tissues. Others have limited or no capacity to regenerate and repair, such as nervous tissue. Most organs have a functional reserve capacity so that they can continue to perform their body function although perhaps in somewhat diminished ability. For example:

- Half of a person's liver can be damaged, and the body can regenerate sufficient new liver or repair the damaged section by fibrous replacement to maintain most of the capacity of the original liver.
- The hypertrophy of one kidney to assume the capacity lost when the other kidney has been lost or surgically removed.

### Toxic Damage to Cells and Tissues

Toxic damage to cells and tissues can be transient and non-lethal or, in severe situations, the damage may cause death of the cells or tissues. The following diagram illustrates the various effects that can occur with damage to cells. There are four main final endpoints to the cellular or biochemical toxicity:

1. The tissue may be completely repaired and return to normal.
2. The tissue may be incompletely repaired but is capable of sustaining its function with reduced capacity.
3. Death of the organism or the complete loss of a tissue or organ. In some instances, the organism can continue to live with the aid of medical treatment, for example, replacement of insulin or by organ transplantations.
4. Neoplasm or cancers may result, many of which will result in death of the organism and some of which may be cured by medical treatment.

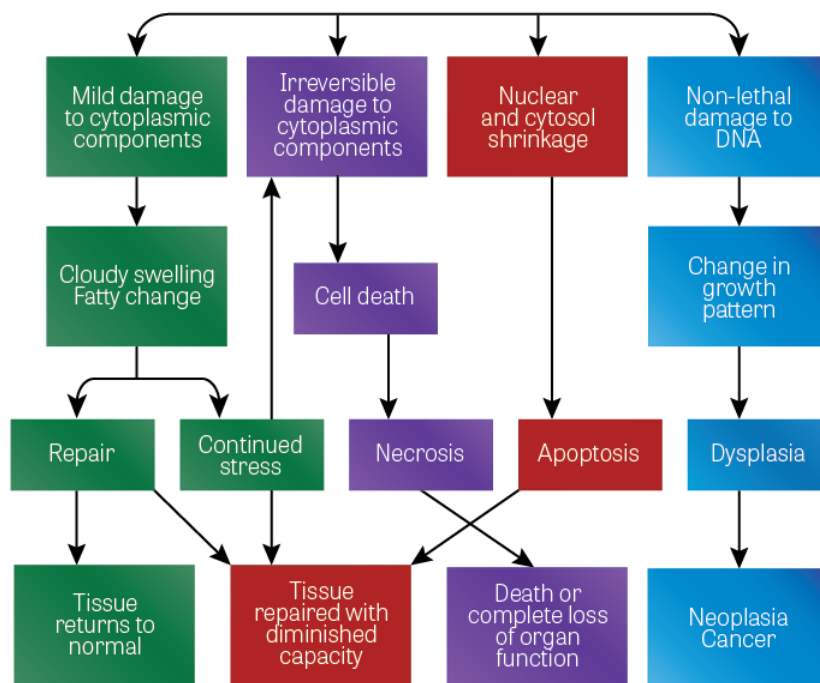

Figure 14.2.1 Toxic damage to cells  
(Image Source: NLM)

## Reversible Cell Damage

The response of cells to toxic injury may be transient and reversible once the stress has been removed or the compensatory cellular changes are made. In some cases, the full capability of the damaged cells returns. In other cases, a degree of permanent injury remains with a diminished cellular or tissue capacity. In addition to the adaptive cell changes discussed previously, two commonly encountered specific cell changes are associated with toxic exposures, cellular swelling, and fatty change.

**Cellular swelling**, which is associated with hypertrophy, is due to cellular hypoxia, which damages the sodium-potassium membrane pump. This in turn changes the intracellular electrolyte balance with an influx of fluids into the cell, causing it to swell. Cell swelling is reversible when the cause is eliminated.

**Fatty change** is more serious and occurs with severe cellular injury. In this situation, the cell has become damaged and is unable to adequately metabolize fat. The result is that small vacuoles of fat accumulate and become dispersed within the cytoplasm. While fatty change can occur in several organs, it is usually observed in the liver. This is because most fat is synthesized and metabolized in liver cells. Fatty change can be reversed but it is a much slower process than the reversal of cellular swelling.

## Lethal Injury (Cell Death)

In many situations, the damage to a cell may be so severe that the cell cannot survive. Cell death occurs mainly by two methods: necrosis and apoptosis.

**Necrosis** is a progressive failure of essential metabolic and structural cell components usually in the cytoplasm. Necrosis generally involves a group of contiguous cells or occurs at the tissue level. Such progressive deterioration in structure and function rapidly leads to cell death or "necrotic cells." Necrosis begins as a reduced production of cellular proteins, changes in electrolyte gradient, or loss of membrane integrity (especially increased membrane permeability). Cytoplasmic organelles (such as mitochondria and endoplasmic reticulum) swell while others (especially ribosomes) disappear. This early phase progresses to fluid accumulation in the cells making them pale-staining or showing vacuoles, which pathologists call "cloudy swelling" or "hydropic degeneration." In

some cells, they no longer can metabolize fatty acids so that lipids accumulate in the cytoplasmic vacuoles, referred to as "fatty accumulation" or "fatty degeneration." In the final stages of "cell dying," the nucleus becomes shrunken (pyknosis) or fragmented (karyorrhexis).

**Apoptosis** or "programmed cell death" is a process of self-destruction of the cell nucleus. Apoptosis is an individual or single cell death in that dying cells are not contiguous but are scattered throughout a tissue. Apoptosis is a normal process in cell turnover in that cells have a finite lifespan and spontaneously die. During embryonic development, certain cells are programmed to die and are not replaced, such as the cells between each developing finger. If the programmed cells do not die, the fetus ends up with incomplete or fingers joined together in a web fashion.

In apoptosis, the cells shrink from a decrease of cytosol and the nucleus. The organelles (other than the nucleus) appear normal in apoptosis. The cell disintegrates into fragments referred to as "apoptotic bodies." These apoptotic bodies and the organelles are phagocytized by adjacent cells and local macrophages without initiation of an inflammatory response as is seen in necrosis. The cells undergo apoptosis and just appear to "fade away." Some toxicants induce apoptosis or, in other cases, they inhibit normal physiological apoptosis.

Following necrosis, the tissue attempts to regenerate with the same type of cells that have died. When the injury is minimal, the tissue may effectively replace the damaged or lost cells. In severely damaged tissues or long-term chronic situations, the ability of the tissue to regenerate the same cell types and tissue structure may be exceeded, so that a different and imperfect repair occurs.

- An example of this is with chronic alcoholic damage to liver tissue in which the body can no longer replace hepatocytes with hepatocytes but rather connective tissue replacement occurs. Fibrocytes with collagen replace the hepatocytes and normal liver structure with scar tissue. The fibrotic scar tissue shores up the damage but it cannot replace the function of the lost hepatic tissue. With constant fibrotic change, the liver function is continually diminished so that eventually the liver can no longer maintain homeostasis. This fibrotic replacement of the liver is known as cirrhosis (Figure 14.2.2). The normal dark-red, glistening smooth appearance of the liver has been replaced with light, irregular fibrous scar tissue that permeates the entire liver.

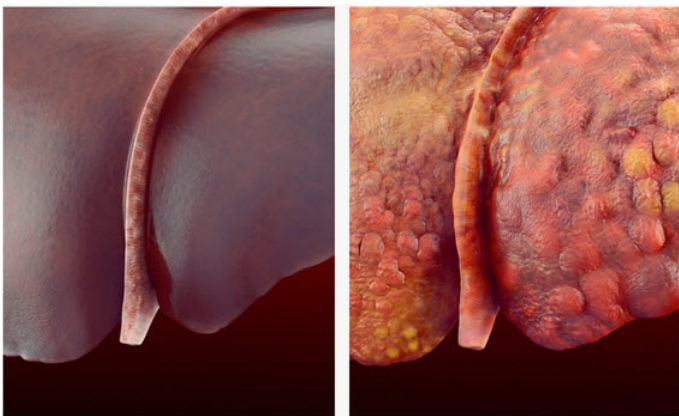

Figure 14.2.2 A healthy liver (left) and a liver with cirrhosis (right)  
(Image Source: iStock Photos, ©)

We have so far discussed primarily changes to individual cells. However, a tissue and an organ consist of different types of cells that work together to achieve a particular function. As with a football team, when one member falters, the others rally to compensate. It is the same with a tissue. Damage to one cell type prompts reactions within the tissue to compensate for the injury. Within organs, there are two basic types of tissues: the parenchymal and stromal tissues. The **parenchymal tissues** contain the functional cells (for example, squamous dermal cells, liver hepatocytes, and pulmonary alveolar cells). The **stromal cells** are the supporting connective tissues (for example, blood vessels and elastic fibers).

## Cell Repair

Repair of injured cells can be accomplished by either:



1. Regeneration of the parenchymal cells.
2. Repair and replacement by the stromal connective tissue.

The goal of the repair process is to fill the gap that results from the tissue damage and restore the structural continuity of the injured tissue. Normally a tissue attempts to regenerate the same cells that are damaged; however, in many cases, this cannot be achieved so that replacement with a stromal connective tissue is the best means for achieving the structural continuity.

The ability to **regenerate** varies greatly with the type of parenchymal cell. The regenerating cells come from the proliferation of nearby parenchymal cells, which serve to replace the lost cells. Based on regenerating ability, there are three types of cells:

1. **Labile cells** — cells that routinely divide and replace cells that have a limited lifespan (for example, skin epithelial cells, and hematopoietic stem cells).
2. **Stable cells** — cells that usually have a long lifespan with normally a low rate of division; they can rapidly divide upon demand.
3. **Permanent cells** — cells that never divide and do not have the ability for replication even when stressed or when some cells die.

Table 14.2.1 shows examples of cell types.

Cell Type	Examples
<b>Labile cells</b>	<ul style="list-style-type: none"> <li>• Squamous epithelium of skin, mouth, vagina, and cervix</li> <li>• Columnar epithelium of intestinal tract</li> <li>• Transitional epithelium of urinary tract</li> <li>• Bone marrow cells</li> </ul>
<b>Stable cells</b>	<ul style="list-style-type: none"> <li>• Liver hepatocytes</li> <li>• Alveolar cells of lung</li> <li>• Epithelium of kidney tubules</li> </ul>
<b>Permanent cells</b>	<ul style="list-style-type: none"> <li>• Neurons</li> <li>• Skeletal and cardiac muscle</li> </ul>

*Table 1. Examples of three cell types of parenchymal cells*

Cell Type	Examples
<b>Labile cells</b>	<ul style="list-style-type: none"> <li>• Squamous epithelium of skin, mouth, vagina, and cervix</li> <li>• Columnar epithelium of intestinal tract</li> <li>• Transitional epithelium of urinary tract</li> <li>• Bone marrow cells</li> </ul>
<b>Stable cells</b>	<ul style="list-style-type: none"> <li>• Liver hepatocytes</li> <li>• Alveolar cells of lung</li> <li>• Epithelium of kidney tubules</li> </ul>
<b>Permanent cells</b>	<ul style="list-style-type: none"> <li>• Neurons</li> <li>• Skeletal and cardiac muscle</li> </ul>

The labile cells have a great potential for regeneration by replication and repopulation with the same cell type so long as the supporting structure remains intact. Stable cells can also respond and regenerate but to a lesser degree and are quite dependent on the supporting stromal framework. When the stromal framework is damaged, the regenerated parenchymal cells may be irregularly dispersed in the organ resulting in diminished organ function. The tissue response for the labile and stable cells is initially hyperplasia until the organ function becomes normal again. When permanent cells die they are not replaced in kind but instead connective tissue (usually fibrous tissue) moves in to occupy the damaged area. This is a form of metaplasia.

Examples of replacement by metaplasia are:

- **Cirrhosis of the liver** — liver cells (hepatocytes) are replaced by bands of fibrous tissue, which cannot carry out the metabolic functions of the liver.
- **Cardiac infarcts** — cardiac muscle cells do not regenerate and thus are replaced by fibrous connective tissue (scar). The scar cannot transmit electrical impulses or participate in contraction of the heart.
- **Pulmonary fibrosis** — damaged or dead epithelial cells lining the pulmonary alveoli are replaced by fibrous tissue. Gases cannot diffuse across the fibrous cells and thus gas exchange is drastically reduced in the lungs.

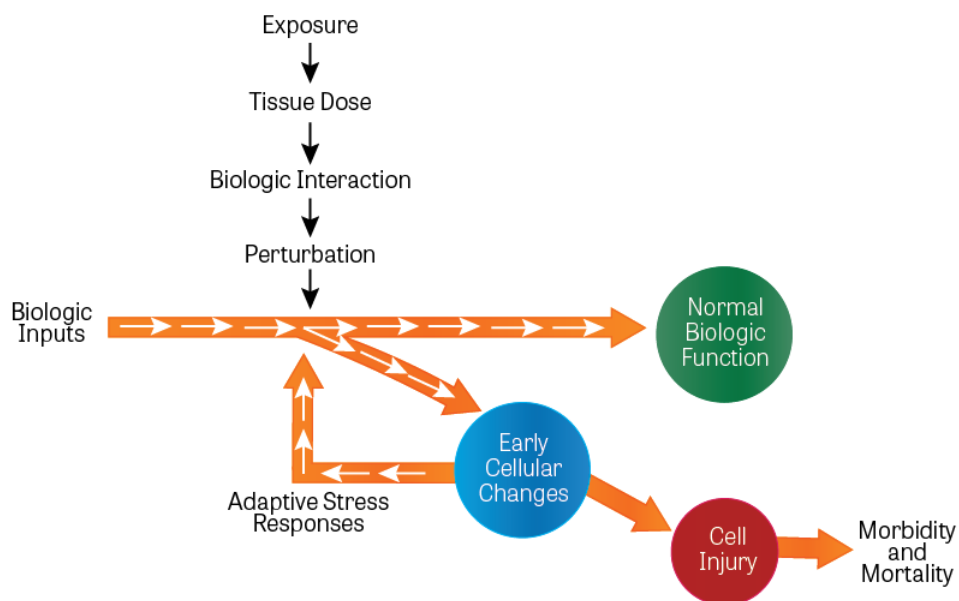

Figure 14.2.3 Activation of Toxicity Pathways

(Image Source: Adapted from Dr. Andrew Maier, adapted from National Research Council (NRC) 2007a.)

### Knowledge Check

**1) The process of self-destruction of the cell nucleus (often referred to as "*programmed cell death*") is known as:**

- Necrosis
- Apoptosis
- Cellular swelling
- Fatty change

**Answer**

Apoptosis - **This is the correct answer.**

Apoptosis (referred to as "*programmed cell death*") is a process of self-destruction of the cell nucleus.

**2) The category of cells that routinely divide and replace cells that have a limited lifespan is known as:**

- Labile cells
- Stable cells
- Permanent cells

**Answer**

Labile cells - **This is the correct answer.**

Labile cells are cells that routinely divide and replace cells that have a limited lifespan (e.g., skin epithelial cells and

hematopoietic stem cells).

This page titled [14.2: Cell Damage and Tissue Repair](#) is shared under a [CC BY-NC 4.0](#) license and was authored, remixed, and/or curated by [ToxMSDT Online component](#) via [source content](#) that was edited to the style and standards of the LibreTexts platform.

## 14.3: Cancer

# Cancer

Cancer has long been considered a cellular disease since cancers are composed of cells that grow without restraint in various areas of the body. Such growths of cancerous cells can replace normal cells or tissues causing severe malformations (such as with skin and bone cancers) and failure of internal organs which frequently leads to death. How do cells become cancerous? The development of cancer is an enormously complex process. For once a cell has started on the cancer path, it progresses through a series of steps, which continue long after the initial cause has disappeared.

## Overview

There are about as many types of cancers as there are different types of cells in the body (over 100 types). Some cell types constantly divide and are replaced (such as skin and blood cells). Other types of cells rarely or never divide (such as bone cells and neurons). Sophisticated mechanisms exist in cells to control when, if, and how cells replicate. Cancer occurs when these mechanisms are lost and replication takes place in an uncontrolled and disorderly manner. It can arise when one cell or a small group of cells multiplies too many times because of damage to its DNA.

Recent research has begun to unravel the extremely complex pathogenesis of cancer. There is an intricate array of biochemical changes that take place within cells and between cells underlying the progression of cancer that transforms normal cells into cancerous cells. These biochemical changes lead a cell through a series of steps, changing it gradually from a normal to a cancer cell. The altered cell is no longer bound by the regulatory controls that govern the life and behavior of normal cells.

Cancer is not a single disease but a large group of diseases. The common aspect is that all cancers have the same basic property: they are composed of cells that no longer conform to the usual constraints on cell proliferation. In other words, they are uncontrolled growths of cells.

## Terminology

The terminology associated with cancer can be confusing and may be used differently among the public and medical communities. Here are definitions of the most frequently used cancer terms:

- **Cancer** — a malignant tumor that has the ability to metastasize or invade into surrounding tissues.
- **Tumor** — a general term for an uncontrolled growth of cells that becomes progressively worse with time. Tumors may be benign or malignant.
- **Neoplasm** — same as a tumor.
- **Neoplasia** — the growth of new tissue with abnormal and unregulated cellular proliferation.
- **Benign Tumor** — a tumor that does not metastasize or invade surrounding tissue.
- **Malignant Tumor** — a tumor that has the ability to metastasize or invade into surrounding tissues (same as cancer).
- **Metastasis** — ability to establish secondary tumor growth at a new location away from the original site.
- **Carcinogenesis** — the production of a carcinoma (epithelial cancer). Sometimes carcinogenesis is used as a general term for production of any type of tumor.

## How are Cancers Named?

While most tumors are generally named in accordance with an [internationally agreed-upon classification scheme](#), there are exceptions. Tumors are generally named and classified based on:

- The cell or tissue of origin
- Whether benign or malignant

Most tumor names end with the suffix "oma" which indicates a swelling or tissue enlargement. [Note: some terms ending with -oma are not cancers; for example, a hematoma is merely a swelling consisting of blood].

In naming tumors, qualifiers may be added in addition to the tissue of origin and structural features. For example, a "poorly-differentiated bronchogenic squamous cell carcinoma" is a malignant tumor (carcinoma) of squamous cell type (original cell type), which arose in the bronchi of the lung (site where the cancer started), and in which the cancer cells are poorly differentiated, meaning they have lost much of the normal appearance of squamous cells.

There are several historical exceptions to the standard nomenclature system, often based on their early and accepted use in the literature.

Examples include:

- Some tumors are named after the person that first described the tumor, for example, Wilms tumor (kidney tumor) and Hodgkin lymphoma (a specific form of lymphoid cancer).
- A few cancers are named for their physical characteristics such as pheochromocytomas (dark-colored tumors of the adrenal gland).
- A few cancers are composed of mixtures of cells, for example, fibrosarcoma and carcinosarcoma.

Most malignant tumors fall into one of two categories: carcinomas or sarcomas. The major differences between carcinomas and sarcomas are listed in Table 14.3.1:

Carcinoma	Sarcoma
<ul style="list-style-type: none"><li>• Malignant tumor arising in epithelium</li><li>• The most common form of cancer</li><li>• Usually spread in lymphatic system</li></ul>	<ul style="list-style-type: none"><li>• Malignant tumor arising in connective or muscle tissue</li><li>• Usually spread by blood stream</li><li>• Frequently metastasizes to lung</li></ul>

## Differences between Benign and Malignant Tumors

The biological and medical consequences of a tumor depend on whether it is benign or malignant.

Table 14.3.2 provides a comparison of the primary differences between benign and malignant tumors:

Characteristics	Benign Tumors	Malignant Tumors
<b>Cell characteristics</b>	Similar to cell of origin (well differentiated)	Dissimilar from cell of origin (poorly differentiated)
<b>Growth characteristics</b>	Tumor edges move outward in a smooth manner (encapsulated), grows by expansion, and compresses and displaces surrounding tissues  Tumor cells stay attached to the clone or mass of cells and do not break away and start new growths elsewhere in the body	Tumor edges move outward in an irregular fashion (usually no capsule) and can infiltrate, invade, and destroy surrounding tissues  Tumor cells can break away from the cloned mass, live independently, move to other areas of the body, and start new clones or growths
<b>Rate of growth</b>	Slow	Rapid
<b>Degree of vascularity</b>	Slight	Moderate-marked
<b>Recurrence after surgical removal</b>	Seldom	Frequently
<b>Degree of necrosis and ulceration</b>	Unusual	Common
<b>Likelihood of causing systemic effects</b>	Unusual unless the tumor is a secreting endocrine neoplasm	Common and usually life-threatening

## Common Sites for Cancer

Cancer can occur in almost any tissue or organ. Some cells and tissues are more likely to become cancerous than others are, particularly those [cells that normally undergo proliferation](#) to replace cells that have been lost due to injury or cell death. Those cells that don't proliferate (for example, neurons and heart muscle cells) rarely give rise to cancers. Figure 14.3.1 illustrates the most frequent occurrence of cancers in various body sites.

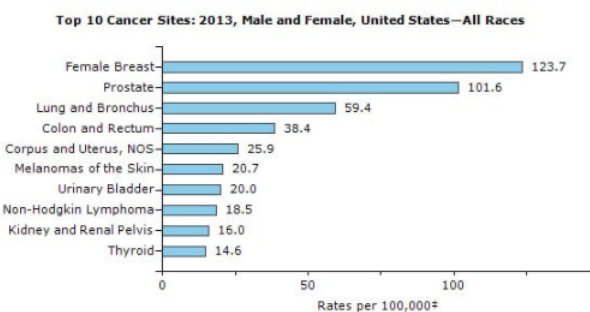

Figure 14.3.1 Top 10 Cancer Sites for Males and Females from All Races in the United States in 2013 (Image Source: CDC, <https://nccd.cdc.gov/uscs/toptencancers.aspx>)

‡ Rates are age-adjusted to the 2000 U.S. standard population (19 age groups – Census P25–1130)

While the prostate is the most common type of cancer that occurs in men, most survive with treatment. In contrast, other types of cancer are more often fatal. For example, the most common cancer, which causes death in men, even with treatment, is lung cancer. With women, a similar situation exists in that the breast is the most common site for cancer but more women die as a result of lung cancer.

## What Do Cancers Look Like?

Cancer is a general term for more than 100 different cellular diseases, all with the same characteristic – the uncontrolled abnormal growth of cells in different parts of the body. Cancers appear in many forms. A few types are visible to the unaided eye but others grow inside the body and slowly destroy or replace internal tissues.

### Skin Cancer

An example of a cancer that can be easily seen by the unaided eye is skin cancer. Skin cancers appear as raised, usually dark-colored, irregularly-shaped growths on the skin. As the cancer grows, it spreads to nearby areas of the skin. In advanced cases, the cancer metastasizes to lymph nodes and organs far away from the original site. The skin cancer illustrated in Figure 14.3.2 is known as a basal cell carcinoma. Melanomas and squamous cell carcinomas are other common skin cancers. Melanomas are usually the most malignant of the skin cancers.

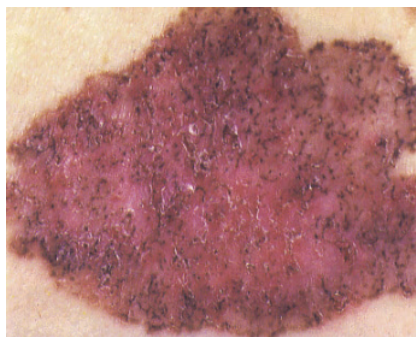

Figure 14.3.2 Photograph of basal cell carcinoma of the skin  
(Image Source: NLM)

### Other Cancers

Most cancers involve internal organs and require elaborate diagnostic tests to diagnose. Some large internal tumors can be felt or will push the skin outward and can be detected by noting abnormal bulges or an abnormal feel (for example, a hard area) to the body. Thyroid tumors, bone tumors, breast tumors, and testicular tumors are cancers that might be felt or observed by the patient. Other internal tumors may only be suspected based on diminished organ function (such as difficulty breathing with lung cancers), pain, bleeding (for example, blood in feces with colon cancer), weakness, or other unusual symptoms. To confirm the actual existence of a cancer may require diagnostic tests. This is especially the case where the cancer is not growing as a single large lump, but rather as a series of small tumors (metastatic foci) or when widely dispersed throughout the body (such as leukemia). A few examples of internal cancers are presented in the following figures.

#### Liver Cancer

Numerous cancer nodules can be seen showing that much of the liver has been destroyed (Figure 14.3.3).

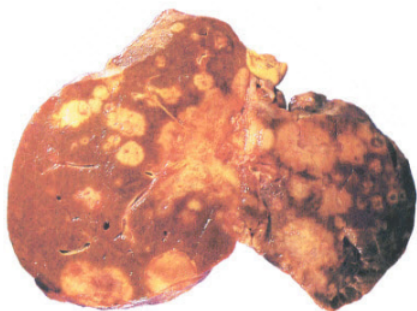

Figure 14.3.3 A liver with numerous cancer nodules  
(Image Source: NLM)

## Lung Cancer

An early developing squamous cell carcinoma can be seen growing in the middle of the lung (Figure 14.3.4). As the cancer develops, it will consume more of the lung and metastasize to other areas of the body.



Figure 14.3.4 A cancerous lung  
(Image Source: NLM)

## Kidney Cancer

The photograph in Figure 14.3.5 shows the cancer has consumed much of the upper portion of the kidney.

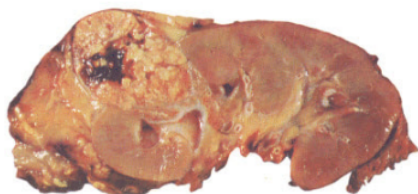

Figure 14.3.5 A kidney with cancer  
(Image Source: NLM)

## Historical Changes in Incidence of Cancer

Cancer has been recognized in humans for centuries. However, the incidence of various types of cancer has changed since the mid-1900s. This is especially true for lung and stomach cancer. Deaths from lung cancer hit a peak in the early 1990s and have been slowly declining since 2001. During that same period, deaths from stomach cancer decreased substantially. Breast cancer caused more deaths than any other type cancer in women for many decades. However, when women began smoking cigarettes, deaths from lung cancer outpaced deaths from breast cancer. These changes in types and incidences of cancer reflect the increased longevity of people as well as personal habits and environmental changes.

## Latency Period for Cancer Development

Cancer is a chronic condition, which develops gradually over a period of time, and may become a clinical concern many years following the initial exposure to a carcinogen. This period of time is referred to as the **latency period**. The latency period varies with the type of cancers and may be as short as a few years to over 30 years. For example, the latency period for leukemia after benzene or radiation exposure may only be five years. In contrast, the latency period may be 20–30 years for skin cancer after arsenic exposure and mesothelioma (cancer of the pleura around the lungs) after asbestos exposure.

## Survival Time

Success in treating cancer varies greatly with the type of cancer with some cancers responding to treatment whereas others do not. For example, medical treatment of cancers of the pancreas, liver, esophagus, and lung are largely unsuccessful. In contrast, cancers of the thyroid, testes, and skin respond quite well to treatment. Table 14.3.3 shows the 5-year survival rate by cancer location.



Organ	Male 5-year Survival	Female 5-year Survival
Pancreas	7.6%	7.8%
Liver	17.1%	18.5%
Esophagus	18.3%	18.5%
Lung and Bronchus	14.9%	20.8%
Stomach	28.5%	33.2%
Brain and Nervous System	32.8%	35.1%
Leukemia	60.7%	58.3%
Ovary	-----	46.2%
Non-Hodgkin Lymphoma	69.2%	72.4%
Oral Cavity and Pharynx	65.0%	67.0%
Kidney	73.0%	75.0%
Colon/Rectum	64.9%	65.2%
Cervix	-----	67.5%
Hodgkin Lymphoma	85.4%	87.7%
Breast	83.6%	89.7%
Prostate	98.9%	-----
Urinary Bladder	78.9%	73.0%
Melanoma of the Skin	89.5%	94.0%
Testes	95.4%	-----
Thyroid	95.7%	98.7%
All Sites	67.0%	66.9%

Table 14.3.3 Five year survival rate by primary cancer site (2006-2012)

(Source: Table 1. Surveillance, Epidemiology, and End Results Program (SEER), National Cancer Institute, [https://seer.cancer.gov/csr/1975\\_2013/results\\_merged/topic\\_survival.pdf](https://seer.cancer.gov/csr/1975_2013/results_merged/topic_survival.pdf))

## What Causes Cancer?

A large number of industrial, pharmaceutical, and environmental chemicals have been identified as potential carcinogens by animal tests. Human epidemiology studies have confirmed that many are human carcinogens as well. However, while **it is apparent** that chemicals and radiation play a substantial role, it appears that lifestyle factors (such as diet, obesity, and smoking), and infections (such as hepatitis B, hepatitis C, and **Human Papillomaviruses**) are also major factors leading to the likelihood that a person will develop cancer. Additional factors that are involved in the development of cancer include aging and heredity.

## Pathogenesis of Cancer

**Carcinogenesis** is a multi-step, multi-factorial genetic disease. All known tumors are composed of cells with genetic alterations that make them perform differently from their progenitor (parent) cells. The carcinogenesis process is very complex and unpredictable consisting of several phases and involving multiple genetic events (mutations) that take place over a very long period of time, at least 10 years for most types of cancer.

Cancer cells do not necessarily proliferate faster than their normal progenitors. In contrast to normal proliferating tissues where there is a strict and controlled balance between cell death and replacement, cancers grow and expand since more cancer cells are produced than die in a given time period. For a tumor to be detected it must attain a size of at least one cubic centimeter (about the size of a pea). This small tumor contains 100 million to a billion cells at that time. The development from a single cell to that size also means that the mass has doubled at least 30 times. During the long and active period of cell proliferation, the cancerous cells may have become aggressive in growth and have reverted to a less differentiated type cell that is not similar to the original cell type.

While knowledge of carcinogenesis continues to evolve, it is clear that there are at least three main phases in cancer development:

1. Initiation
2. Promotion/Conversion
3. Progression

Operational Phases	Biochemical Mechanisms	Clinical Appearance
Initiation	Mutation <i>Permanent DNA damage</i>	No noticeable change
Promotion	Stimulation of growth of altered cells	Usually only detected by biopsy
Conversion	Mutation <i>Uncontrolled growth and expansion</i>	Benign tumor <i>Expansive growth</i>
Progression	Mutation <i>Complete loss of cellular control</i>	Cancer <i>Invasion and metastasis</i>

Figure 14.3.6 Phases of carcinogenesis  
(Image Source: NLM)

## 1. Initiation

The **initiation** phase consists of the alteration of the DNA (mutation) of a normal cell, which is an irreversible change. The initiated cell has developed a capacity for individual growth. At this time, the initiated cell is indistinguishable from other similar cells in the tissue. The initiating event can consist of a single exposure to a carcinogenic agent or, in some cases, it may be an inherited genetic defect.

- An example is retinoblastoma in which some children who develop the disease may have inherited an altered copy of the gene involved and are at risk of passing the altered gene to successive generations.

The initiated cell, whether inherited or newly mutated, may remain dormant for months to years and, unless a promoting event occurs, may never develop into a clinical cancer case.

## 2. Promotion/Conversion

The **promotion/conversion** phase is the second major step in the carcinogenesis process in which specific agents (referred to as promoters) enhance the further development of the initiated cells. Promoters often, but not always, interact with the cell's DNA and influence the further expression of the mutated DNA so that the initiated cell proliferates and progresses further through the

carcinogenesis process. The clone of proliferating cells in this stage takes a form consistent with a benign tumor. The mass of cells remains as a cohesive group and physically keeps in contact with each other.

### 3. Progression

**Progression** is the third recognized step and is associated with the development of the initiated cell into a biologically malignant cell population. In this stage, a portion of the benign tumor cells may be converted into malignant forms so that a true cancer has evolved. Individual cells in this final stage can break away and start new clones of growth distant from the original site of development of the tumor. This is known as **metastasis**.

### Genetic Activity

While the three-stage pathogenesis scheme describes the basic sequence of events in the carcinogenesis process, the actual events that take place in these various steps are due to activities of specific genes within the DNA of the cells. Cellular DNA contains two types of genes:

1. **Structural genes** direct the production of specific proteins within the cell.
2. **Regulatory genes** control the activity of the structural genes and direct the proliferation process of the cell.

The three classes of regulatory genes considered to have major roles in the carcinogenesis process are known as:

1. Proto-oncogenes
2. Oncogenes
3. Suppressor genes

**Proto-oncogenes** are normal cellular genes that encode and instruct the production of the regulatory proteins and growth factors within the cell or its membrane. The proteins encoded by proto-oncogenes are necessary for normal cellular cell growth and differentiation. Activation of a proto-oncogene can cause the alteration in the normal growth and differentiation of cells, which leads to neoplasia. Several agents can activate proto-oncogenes. This is the result of [point mutations](#) or by DNA rearrangements of the proto-oncogenes. The product of this proto-oncogene activation is an oncogene. Many proto-oncogenes have been identified and have usually been named after the source of their discovery, for example, the KRAS proto-oncogene was named for the discovery using the Kirsten rat sarcoma virus. HRAS, MYC, MYB, and SRC are other examples of proto-oncogenes. The proto-oncogenes are not specific for the original species but have been found in many other species, including humans. These proto-oncogenes are present in many cells but remain dormant until activated. Either a point mutation or chromosomal damage of various types can induce activation. Once activated they become an oncogene.

**Oncogenes** are altered or misdirected proto-oncogenes which now have the ability to direct the production of proteins within the cell that can change or transform the normal cell into a neoplastic cell. Most oncogenes differ from their proto-oncogenes by a single point mutation located at a specific codon (a group of three DNA bases that encodes for a specific amino acid) of a chromosome. The altered DNA in the oncogene results in the production of an abnormal protein that can alter cell growth and differentiation. It appears that a single activated oncogene is not sufficient for the growth and progression of a cell and its offspring to form a cancerous growth. However, it is a major step in the carcinogenesis process.

**Tumor suppressor genes**, sometimes referred to as anti-oncogenes, are present in normal cells and serve to counteract and change the proto-oncogenes and altered proteins that they are responsible for. The tumor suppressor genes serve to prevent a cell with damaged DNA from proliferating and evolving into an uncontrolled growth. They actively function to effectively oppose the action of an oncogene. If a tumor suppressor gene is inactivated (usually by a point mutation), its control over the oncogene and transformed cell may be lost. Thus the tumor-potential cell can now grow without restraint and is free of the normal cellular regulatory control. The suppressor gene most frequently altered in human tumors is the p53 gene. Damaged p53 genes have been identified in over 50% of human cancers.

The **p53 gene** normally halts cell division and stimulates repair enzymes to rebuild and restore the damaged regions of the DNA. If the damage is too extensive, the p53 commands the cell to self-destruct. An altered p53 is incapable of these defensive actions and cannot prevent the cell with damaged DNA from dividing and proliferating in an erratic and uncontrolled manner. This is the essence of cancer.

This section represents only a brief overview of an enormously complex process for which knowledge is continuously evolving with the tools of molecular biology. New factors are continuously being identified; however, many pieces of this cancer puzzle remain elusive at this time.

#### Knowledge Check

**1) A body growth with the ability to metastasize or invade into surrounding tissues is known as a:**

- a) Benign tumor
- b) Malignant tumor
- c) Hyperplasia

**Answer**

Malignant tumor - **This is the correct answer.**

A malignant tumor that has the ability to metastasize or invade into surrounding tissues. It is the same as cancer.

**2) Most cancers are thought to be due to the following:**

- a) Infections
- b) Food additives
- c) Lifestyle factors
- d) Pollution

**Answer**

Lifestyle factors - **This is the correct answer.**

Lifestyle (including diet, tobacco use, reproductive and sexual behavior, and alcohol consumption) is considered to cause about 75% of all cancers.

**3) The initial stage in carcinogenesis in which there is an alteration of the DNA (mutation) is referred to as the:**

- a) Progression stage
- b) Promotion stage
- c) Initiation stage

**Answer**

Initiation stage - **This is the correct answer.**

The initiation phase consists of the alteration of the DNA (mutation) of a normal cell, which is irreversible change.

**4) The cellular gene which is present in most normal cells and serves as a balance to the genes for tumor expression is known as a:**

- a) Tumor suppressor gene
- b) Oncogene
- c) Proto-oncogene

**Answer**

Tumor suppressor gene - **This is the correct answer.**

Tumor suppressor genes, sometimes referred to as anti-oncogenes, are present in normal cells and serve as a balance to the genes for expression or proto-oncogenes.

This page titled [14.3: Cancer](#) is shared under a [CC BY-NC 4.0](#) license and was authored, remixed, and/or curated by [ToxMSDT Online component](#) via [source content](#) that was edited to the style and standards of the LibreTexts platform.

## 14.4: Neurotoxicity

# Neurotoxicity

The nervous system is very complex and toxins can act at many different points in this complex system. The focus of this section is to provide a basic overview of how the nervous system works and how neurotoxins affect it. Due to the complexity of these topics, this section does not include extensive details related to the anatomy and physiology of the nervous system or the many neurotoxins in our environment and the subtle ways they can damage the nervous system or interfere with its functions.

Since the nervous system innervates all areas of the body, some toxic effects may be quite specific and others generalized depending upon where in the nervous system the toxin exerts its effect. Before discussing how neurotoxins cause damage, we will look at the basic anatomy and physiology of the nervous system.

## Anatomy and Physiology of the Nervous System

The nervous system has three basic functions:

1. Specialized cells detect sensory information from the environment and relay that information to other parts of the nervous system.
2. It directs motor functions of the body usually in response to sensory input.
3. It integrates the thought processes, learning, and memory.

All of these functions are potentially vulnerable to the actions of toxicants.

The nervous system consists of two fundamental anatomical divisions:

1. Central nervous system (CNS)
2. Peripheral nervous system (PNS)

## Central Nervous System

The CNS includes the brain and spinal cord. The CNS serves as the control center and processes and analyzes information received from sensory receptors and in response issues motor commands to control body functions. The brain, which is the most complex organ of the body, structurally consists of six primary areas (Figure 14.4.1):

1. **Cerebrum** — controls thought processes, intelligence, memory, sensations, and complex motor functions.
2. **Diencephalon** (*thalamus, hypothalamus, pituitary gland*) — relays and processes sensory information; controls emotions, autonomic functions, and hormone production.
3. **Midbrain** — processes auditory and visual data; generates involuntary motor responses.
4. **Pons** — a tract and relay center which also assists in somatic and visceral motor control.
5. **Cerebellum** — voluntary and involuntary motor activities based on memory and sensory input.
6. **Medulla oblongata** — relays sensory information to the rest of the brain; regulates autonomic function, including heart rate and respiration.

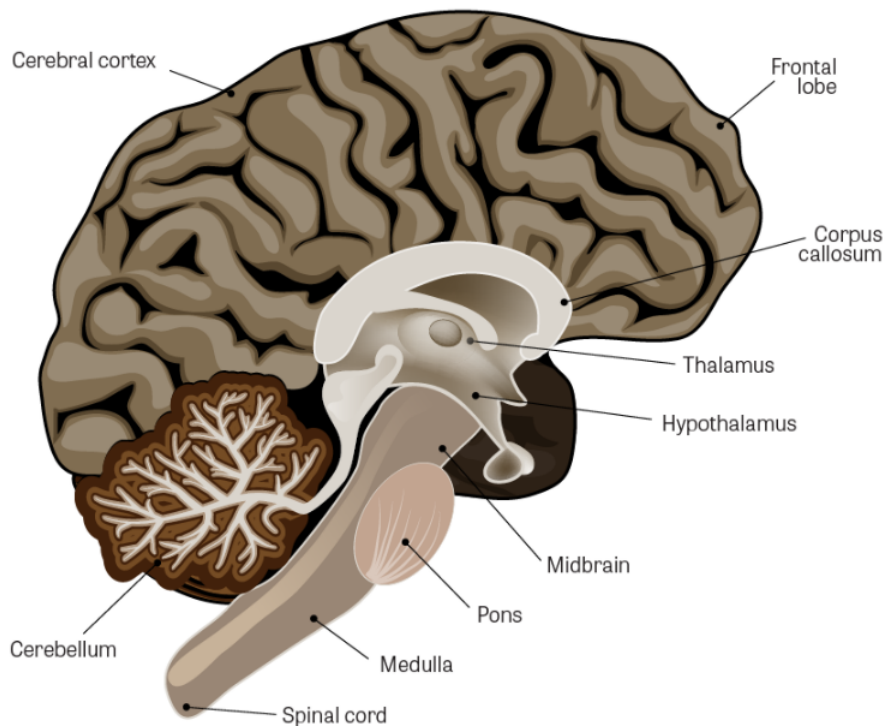

Figure 14.4.1 Internal anatomy of the brain  
(Image Source: Adapted from iStock Photos, ©)

## Peripheral Nervous System

The PNS consists of all nervous tissue outside the CNS (Figure 14.4.2). The PNS contains two forms of nerves:

1. Afferent nerves, which relay sensory information to the CNS.
2. Efferent nerves, which relay motor commands from the CNS to various muscles and glands.

**Efferent nerves** are organized into two systems. One is the **somatic nervous system** that is also known as the voluntary system and which carries motor information to skeletal muscles. The second efferent system is the **autonomic nervous system**, which carries motor information to smooth muscles, cardiac muscle, and various glands. The major difference between these two systems pertains to conscious control.

- The somatic system is under our voluntary control such as moving our arms by consciously telling our muscles to contract.
- In contrast, we cannot consciously control the smooth muscles of the intestine, heart muscle, or secretion of hormones. Those functions are automatic and involuntary as controlled by the autonomic nervous system.



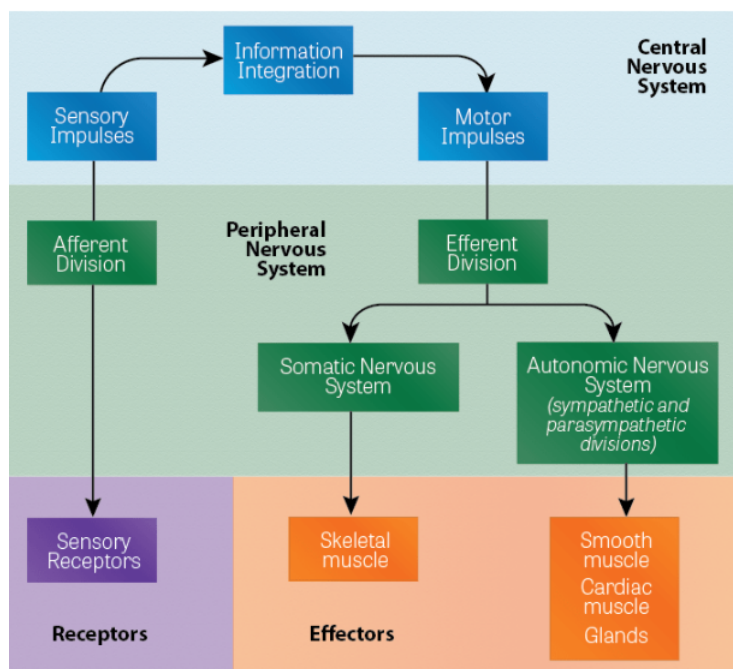

Figure 14.4.2 Structures of the central nervous system and peripheral nervous system  
(Image Source: NLM)

## Cells of the Nervous System

There are two categories of cells found in the nervous system: neurons and glial cells. **Neurons** are the functional nerve cells directly responsible for transmission of information to and from the CNS to other areas of the body. **Glial cells** (also known as neuroglia) provide support to the neural tissue, regulate the environment around the neurons, and protect against foreign invaders.

**Neurons** communicate with all areas of the body and are present within both the CNS and PNS. They serve to transmit rapid impulses to and from the brain and spinal cord to virtually all tissues and organs of the body. As such, they are an essential cell and their damage or death can have critical effects on body function and survival. When neurons die, they are not replaced. As neurons are lost, so are certain neural functions such as memory, ability to think, quick reactions, coordination, muscular strength, and our various senses such as sight, hearing, and taste. If the neuron loss or impairment is substantial, severe and permanent disorders can occur, such as blindness, paralysis, and death.

A neuron consists of a cell body and two types of extensions, numerous dendrites, and a single axon (Figure 14.4.3). **Dendrites** are specialized in receiving incoming information and sending it to the neuron cell body with transmission (electrical charge) on down the axon to one or more junctions with other neurons or muscle cells (known as synapses). The **axon** may extend long distances, over a meter in some cases, to transmit information from one part of the body to another. The **myelin sheath** is a multi-layer coating that wraps some axons and helps insulate the axon from surrounding tissues and fluids, and prevents the electrical charge from escaping from the axon.



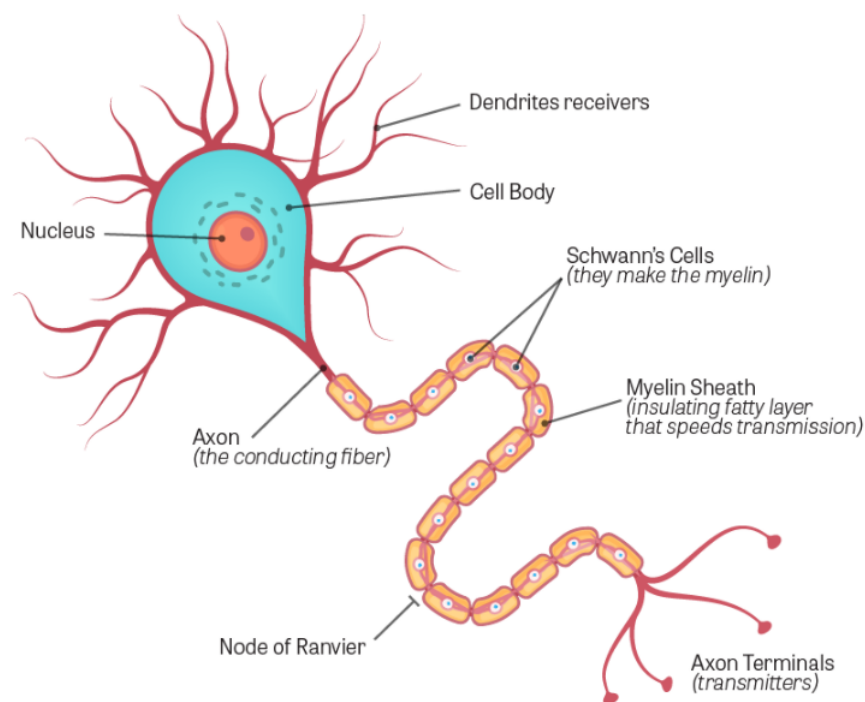

Figure 14.4.3 Neuron structure  
(Image Source: Adapted from iStock Photos, ©)

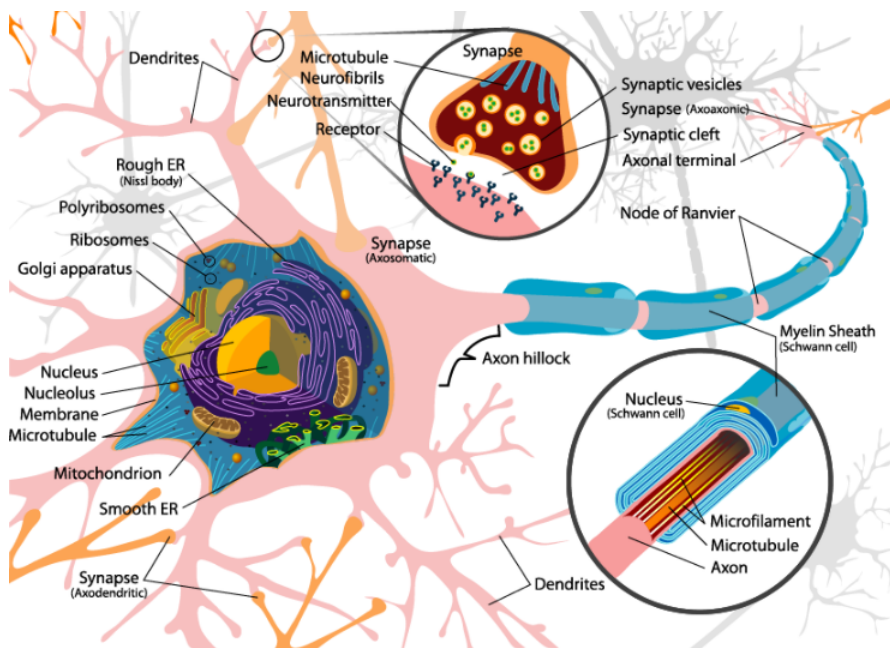

Figure 14.4.4 Complete neuron cell diagram  
(Image Source: Adapted from Wikimedia Commons, obtained under Public Domain. Author: LadyofHats.)

Information passes along the network of neurons between the CNS and the sensory receptors and the effectors by a combination of electrical pulses and chemical neurotransmitters. The information (electrical charge) moves from the dendrites through the cell body and down the axon. The mechanism by which an electrical impulse moves down the neuron is quite complex. When the neuron is at rest, it has a negative internal electrical potential. This changes when a neurotransmitter binds to a dendrite receptor. Protein channels of the dendrite membrane open allowing the movement of charged chemicals across the membrane, which creates an electrical charge. The propagation of an electrical impulse (known as action potential) proceeds down the axon by a continuous

series of openings and closings of sodium-potassium channels and pumps. The action potential moves like a wave from one end (dendritic end) to the terminal end of the axon.

However, the electrical charge cannot cross the gap (synapse) between the axon of one neuron and the dendrite of another neuron or an axon and a connection with a muscle cell (neuromuscular junction). Chemicals called neurotransmitters move the information across the synapse.

Neurons do not make actual contact with one another but have a gap, known as a **synapse**. As the electrical pulse proceeds up or down an axon, it encounters at least one junction or synapse. An electrical pulse cannot pass across the synapse. At the terminal end of an axon is a synaptic knob, which contains the neurotransmitters.

## Neurotransmitters

Vesicles release **neurotransmitters** upon stimulus by an impulse moving down the presynaptic neuron. The neurotransmitters diffuse across the synaptic junction and bind to receptors on the postsynaptic membrane. The neurotransmitter-receptor complex then initiates the generation of an impulse on the next neuron or the effector cell, for example, a muscle cell or secretory cell.

After the impulse has again been initiated, the neurotransmitter-complex must be inactivated or continuous impulses (beyond the original impulse) will be generated. Enzymes perform this inactivation, which serves to break down the complex at precisely the right time and after the exact impulse has been generated. There are several types of neurotransmitters and corresponding inactivating enzymes. One of the major neurotransmitters is acetylcholine with acetylcholinesterase as the specific inactivator.

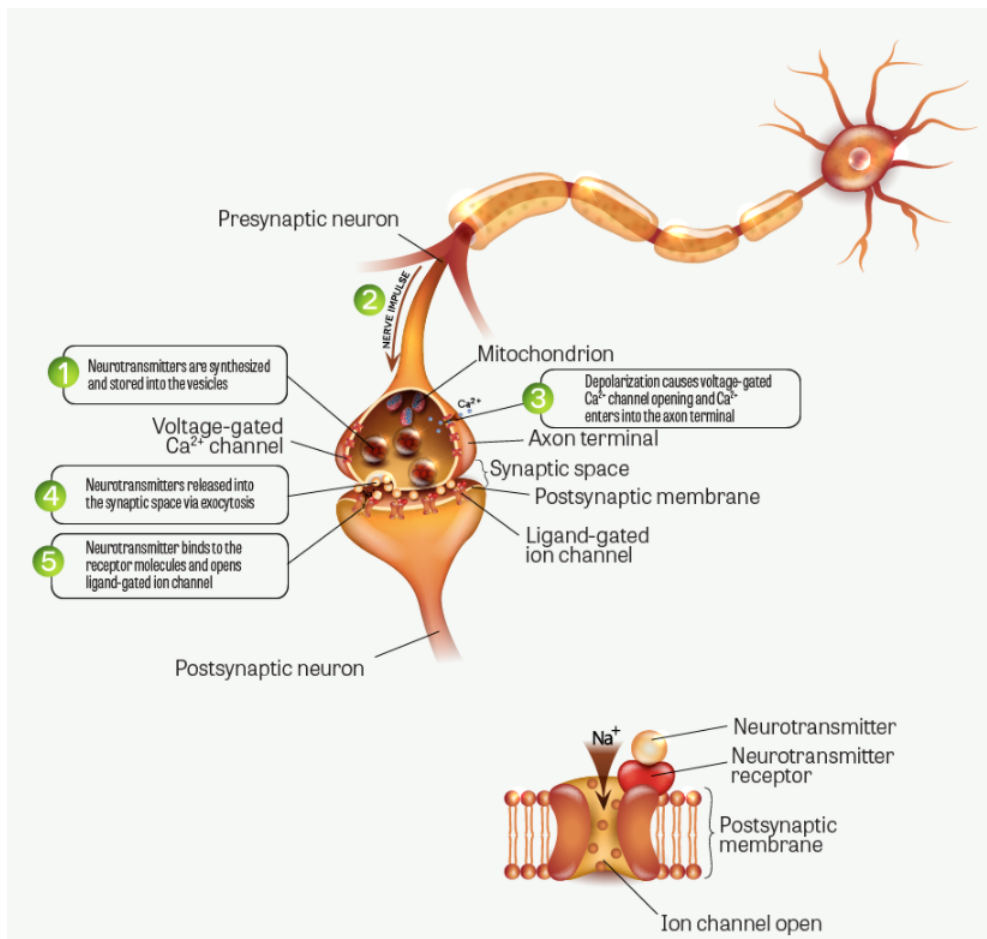

Figure 14.4.5 Impulse transmission across synapse  
(Image Source: Adapted from iStock Photos, ©)

There are over 100 known neurotransmitters. Among the most well-known are:

- Acetylcholine
- Dopamine
- Serotonin
- Norepinephrine
- GABA (gamma-aminobutyric acid)

## Types of Neurons

Neurons are categorized by their function and consist of three types:

1. **Sensory neurons (afferent neurons)** carry information from sensory receptors (usually processes of the neuron) to the CNS. Some sensory receptors detect external changes such as temperature, pressure, and the senses of touching and vision. Others monitor internal changes such as balance, muscle position, taste, deep pressure, and pain.
2. **Motor neurons (effector neurons)** relay information from the CNS to other organs terminating at the effectors. Motor neurons make up the efferent neurons of both the somatic and autonomic nervous systems.
3. **Interneurons (association neurons)** are located only in the CNS and provide connections between sensory and motor neurons. They can carry either sensory or motor impulses. They are involved in spinal reflexes, analysis of sensory input, and coordination of motor impulses. They also play a major role in memory and the ability to think and learn.

## Glial Cells

**Glial cells** are important as they provide a structure for the neurons by protecting them from outside invading organisms, and maintaining a favorable environment (nutrients, oxygen supply, etc.). The neurons are highly specialized and do not have all the usual cellular organelles to provide them with the same life-support capability. They are highly dependent on the glial cells for their survival and function. For example, neurons have such a limited storage capacity for oxygen that they are extremely sensitive to decreases in oxygen (anoxia) and will die within a few minutes. The list below describes the types of glial cells:

- **Astrocytes** are big cells, only in the CNS, and maintain the blood-brain barrier that controls the entry of fluid and substances from the circulatory system into the CNS. They also provide rigidity to the brain structure.
- **Schwann cells and oligodendrocytes** wrap themselves around some axons to form **myelin**, which serves like insulation. Myelinated neurons usually transmit impulses at high speed, such as needed in motor neurons. Loss of myelination causes a dysfunction of these cells.
- **Microglia** are small, mobile, phagocytic cells.
- **Ependymal cells** produce the cerebrospinal fluid (CSF) which surrounds and cushions the central nervous system.

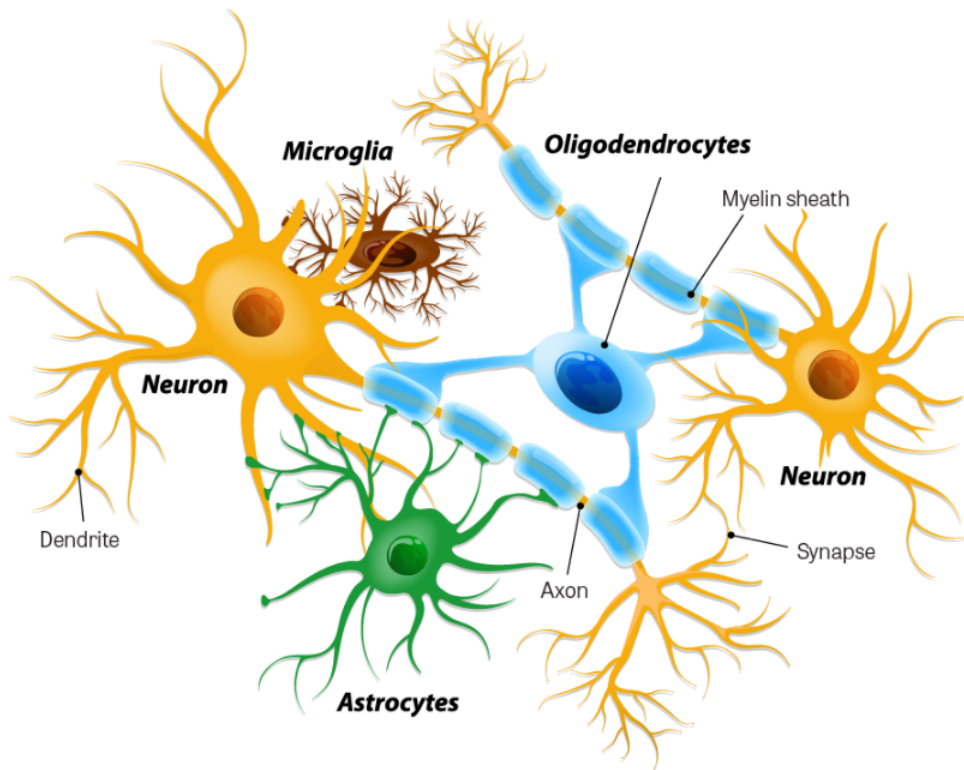

Figure 14.4.6 Neurons and neuroglial cells  
(Image Source: Adapted from iStock Photos, ©)

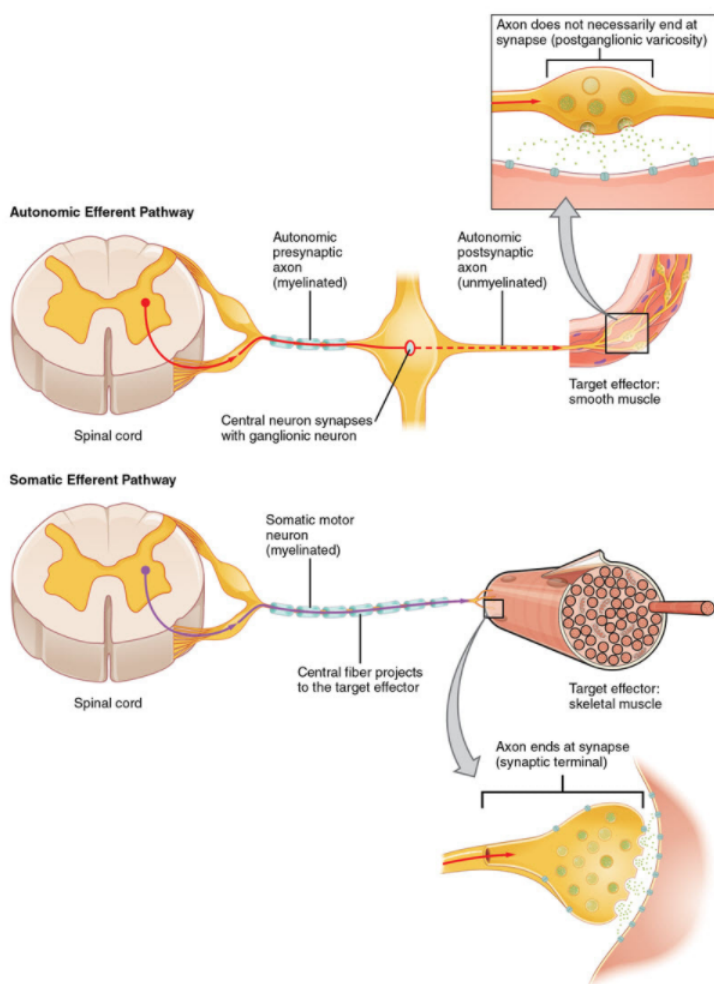

Figure 14.4.7. Comparison of somatic and visceral reflects

(Image Source: Wikimedia Commons, obtained under Creative Commons Attribution 3.0 Unported License. Author: OpenStax College. [View original image](#). Source: Anatomy & Physiology, Connexions Web site. <http://cnx.org/content/col11496/1.6/>, Jun 19, 2013.)

## Toxic Damage to Nervous System

The nervous system is quite vulnerable to toxins since chemicals interacting with neurons can change the critical voltages, which must be carefully maintained. However, the nervous system has defense mechanisms that can protect it from toxins.

Most of the CNS is protected by an anatomical barrier between the neurons and blood vessels, known as the **blood-brain barrier**. It is protected from some toxin exposures by tightening junctions between endothelial cells of the blood vessels in the CNS and having astrocytes surround the blood vessels. This prevents the diffusion of chemicals out of the blood vessels and into the intracellular fluid except for small, lipid-soluble, non-polar molecules. Specific transport mechanisms exist to transport essential nutrients (such as glucose and amino acids and ions) into the brain. Another defense mechanism within the brain to counter chemicals that pass through the vascular barrier is the presence of metabolizing enzymes. Certain detoxifying enzymes, such as monoamine oxidase, can biotransform many chemicals to less toxic forms as soon as they enter the intercellular fluid.

The basic types of changes due to toxins can be divided into three categories – 1) sensory; 2) motor; and 3) interneuronal – depending on the type of damage sustained.

1. Damage can occur to sensory receptors and **sensory neurons**, which can affect the basic senses of pressure, temperature, vision, hearing, taste, smell, touch, and pain.

- For example, heavy metal poisoning (especially lead and mercury) can cause deafness and loss of vision.
  - Several chemicals including inorganic salts and organophosphorus compounds can cause a loss of sensory functions.
2. Damage to **motor neurons** can cause muscular weakness and paralysis.
    - Isonicotinic hydrazide (used to treat tuberculosis) can cause such damage.
  3. **Interneuronal** damage can cause learning deficiencies, loss of memory, incoordination, and emotional conditions.
    - Low levels of inorganic mercury and carbon monoxide can cause depression and loss of memory.

## Mechanisms for Toxic Damage to the Nervous System

Toxic damage to the nervous system occurs by the following basic mechanisms:

1. Direct damage and death of neurons and glial cells.
2. Interference with electrical transmission.
3. Interference with chemical neurotransmission.

### A. Death of Neurons and Glial Cells

The most common cause of death of neurons and glial cells is **anoxia**, an inadequate oxygen supply to the cells or their inability to utilize oxygen. Anoxia may result from the blood's decreased ability to provide oxygen to the tissues (impaired hemoglobin or decreased circulation) or from the cells unable to utilize oxygen.

- For example, carbon monoxide and sodium nitrite can bind to hemoglobin preventing the blood from being able to transport oxygen to the tissues.
- Hydrogen cyanide and hydrogen sulfide can penetrate the blood-brain barrier and is rapidly taken up by neurons and glial cells.
- Another example is sodium fluoroacetate (commonly known as Compound 1080, a rodent pesticide) which inhibits a cellular enzyme.

Those chemicals interfere with cellular metabolism and prevent nerve cells from being able to utilize oxygen. This is called **histoxic anoxia**.

Neurons are among the most sensitive cells in the body to inadequate oxygenation. Lowered oxygen for only a few minutes is sufficient to cause irreparable changes leading to the death of neurons.

Several other neurotoxins directly damage or kill neurons, including:

- Lead
- Mercury
- Some halogenated industrial solvents including methanol (wood alcohol)
- Toluene
- Trimethyltin polybrominated diphenyl ethers (PBDEs)

While some neurotoxic agents affect neurons throughout the body, others are quite selective.

- For example, methanol specifically affects the optic nerve, retina, and related ganglion cells while trimethyltin kills neurons in the hippocampus, a region of the cerebrum.

Other agents can degrade neuronal cell function by diminishing its ability to synthesize protein, which is required for the normal function of the neuron.

- Organomercury compounds exert their toxic effect in this manner.

With some toxins, only a portion of the neuron is affected. If the cell body is killed, the entire neuron will die. Some toxins can cause death or loss of only a portion of the dendrites or axon while the cell itself survives but with diminished or total loss of function. Commonly axons begin to die at the very distal end of the axon with necrosis slowly progressing toward the cell body. This is referred to as "dying-back neuropathy."

- Some organophosphate chemicals (including some pesticides) cause this distal axonopathy. The mechanism for the dying back is not clear but may be related to the inhibition of an enzyme (neurotoxic esterase) within the axon.
- Other well-known chemicals can cause distal axonopathy include ethanol, carbon disulfide, arsenic, ethylene glycol (in antifreeze), and acrylamide.

## B. Interference with Electrical Transmission

There are two basic ways that a foreign chemical can interrupt or interfere with the propagation of the electrical potential (impulse) down the axon to the synaptic junction:

1. To interfere with the movement of the action potential down the intact axon.
2. To cause structural damage to the axon or its myelin coating. Without an intact axon, transmission of the electrical potential is not possible.

Agents that can block or interfere with the sodium and potassium channels and sodium-potassium pump cause interruption of the propagation of the electrical potential. This will weaken, slow, or completely interrupt the movement of the electrical potential. Many potent neurotoxins exert their toxicity by this mechanism.

- Tetrodotoxin (a toxin in frogs, pufferfish, and other invertebrates) and saxitoxin (a cause of shellfish poisoning) blocks sodium channels. Batrachotoxin (a toxin in South American frogs used as arrow poison) and some pesticides (DDT and pyrethroids) increases the permeability of the neuron membrane preventing closure of sodium channels which leads to repetitive firing of the electrical charge and an exaggerated impulse.

A number of chemicals can cause **demyelination**. Many axons (especially in the PNS) are wrapped with a protective myelin sheath that acts as insulation and restricts the electrical impulse within the axon. Agents that selectively damage these coverings disrupt or interrupt the conduction of high-speed neuronal impulses. Loss of a portion of the myelin can allow the electrical impulse to leak out into the tissue surrounding the neuron so that the pulse does not reach the synapse with the intended intensity.

- In some diseases, such as Multiple Sclerosis (MS) and Amyotrophic Lateral Sclerosis (ALS), the myelin is lost, causing paralysis and loss of sensory and motor function.

A number of chemicals can cause demyelination:

- Diphtheria toxin causes loss of myelin by interfering with the production of protein by the Schwann cells that produce and maintain myelin in the PNS.
- Triethyltin (used as a biocide, preservative, and polymer stabilizer) interrupts the myelin sheath around peripheral nerves.
- Lead causes loss of myelin primarily around peripheral motor axons.

## C. Interference with Chemical Neurotransmission

**Synaptic dysfunction** is a common mechanism for the toxicity of a wide variety of chemicals. There are two types of synapses: *those between two neurons* (axon of one neuron and dendrites of another) and *those between a neuron and a muscle cell or gland*. The basic mechanism for the chemical transmission is the same. The major difference is that the neurotransmitting chemical between a neuron and muscle cell is acetylcholine whereas there are several other types of neurotransmitting chemicals involved between neurons, depending on where in the nervous system the synapse is located.

There are four basic steps involved in neurotransmission at the synapse:

1. Synthesis and storage of neurotransmitter (synaptic knob of axon).
2. Release of the neurotransmitter (synaptic knob with movement across synaptic cleft).
3. Receptor activation (effector membrane).
4. Inactivation of the transmitter (enzyme breaks down neurotransmitter stopping induction of action potential).

The arrival of the action potential at the synaptic knob initiates a series of events culminating in the release of the chemical neurotransmitter from its storage depots in vesicles. After the neurotransmitter diffuses across the synaptic cleft, it complexes with a receptor (membrane-bound macromolecule) on the post-synaptic side. This binding causes an ion channel to open, changing the membrane potential of the post-synaptic neuron or muscle or gland. This starts the process of impulse formation or action potential in the next neuron or receptor cell. However, unless this receptor-transmitter complex is inactivated, the channel remains open with continued pulsing. Thus, the transmitter action must be terminated. Specific enzymes that can break the bond and return the receptor-membrane to its resting state do this.

Drugs and environmental chemicals can interact at specific points in this process to change the neurotransmission. Depending on where and how the xenobiotics act, the result may be either an increase or a decrease in neurotransmission. Many drugs (such as tranquilizers, sedatives, stimulants, beta-blockers) are used to correct imbalances to neurotransmissions (such as occurs in



depression, anxiety, and cardiac muscular weakness). The mode of action of some analgesics is to block receptors, which prevent transmission of pain sensations to the brain.

Exposure to environmental chemicals that can perturb neurotransmission is a very important area of toxicology. Generally, neurotoxins affecting neurotransmission act to:

1. Increase or decrease the release of a neurotransmitter at the presynaptic membrane.
2. Block receptors at the postsynaptic membrane.
3. Modify the inactivation of the neurotransmitter.

This is a list of only a few examples of neurotoxins to show the range of mechanisms:

- $\alpha$ -Bungarotoxin (a potent venom of elapid snakes) prevents the release of neurotransmitters.
- Scorpion venom potentiates the release of a neurotransmitter (acetylcholine).
- Black widow spider venom causes an explosive release of neurotransmitters.
- Botulinum toxin blocks the release of acetylcholine at neuromuscular junctions.
- Atropine blocks acetylcholine receptors.
- Strychnine inhibits the neurotransmitter glycine at postsynaptic sites resulting in an increased level of neuronal excitability in the CNS.
- Nicotine binds to certain cholinergic receptors.

A particularly important type of neurotoxicity is the inhibition of acetylcholinesterase. The specific function of acetylcholinesterase is to stop the action of acetylcholine once it has bound to a receptor and initiated the action potential in the second nerve or at the neuro-muscular or glandular junction. If the acetylcholine-receptor complex is not inactivated, continual stimulation will result leading to paralysis and death.

- Many commonly used chemicals, especially organophosphate and carbamate pesticides, poison mammals by this mechanism.
- The major military nerve gases are also cholinesterase inhibitors.

Acetylcholine is a common neurotransmitter. It is responsible for transmission at all neuromuscular and glandular junctions as well as many synapses within the CNS.

Events Involved in a Typical Cholinergic Synapse The complexity of the sequence of events that takes place at a typical cholinergic synapse is indicated below:

Step	Events
1	<ul style="list-style-type: none"> <li>• Electrical impulse arrives at synaptic knob and depolarizes the bulb and presynaptic membrane.</li> <li>• Synaptic vesicles release acetylcholine (<i>ACh</i>).</li> </ul>
2	<ul style="list-style-type: none"> <li>• Calcium ions enter the synaptic knob's cytoplasm.</li> <li>• Synaptic vesicles release ACh.</li> </ul>
3	<ul style="list-style-type: none"> <li>• ACh release stops as calcium ions are removed from the synaptic knob cytoplasm.</li> <li>• The released ACh diffuses across synaptic cleft and binds to receptors on the post-synaptic membrane.</li> <li>• The chemically-regulated receptors cause a graded depolarization on the postsynaptic surface, which then is transmitted on down the axon or into the effector cell.</li> </ul>
4	<ul style="list-style-type: none"> <li>• ACh is broken down by acetylcholinesterase into choline and acetate at the receptor site on the postsynaptic membrane.</li> <li>• Choline is then reabsorbed from the synaptic cleft and is available for resynthesis into more ACh and stored by the synaptic vesicles for future use.</li> </ul>

Table 1. Events that take place at a typical cholinergic synapse

The nervous system is the most complex system of the body. There are still many gaps in understanding how many neurotoxins act, yet research is discovering their possible effects on the body's structures and functions. It is important to understand that the most



potent toxins (on a weight basis) are neurotoxins with extremely minute amounts sufficient to cause death.

#### Knowledge Check

### 1) The two fundamental anatomical divisions of the nervous system are the:

- a) Cerebrum and cerebellum
- b) Central nervous system and peripheral nervous system
- c) Brain and spinal cord

#### Answer

Central nervous system and peripheral nervous system - **This is the correct answer.**

The two fundamental anatomical divisions of the nervous system are the Central Nervous System (brain and spinal cord) and the Peripheral Nervous System, which consists of all nerves outside the brain and spinal cord.

### 2) The two major categories of cells found in the nervous system are:

- a) Neurons and glial cells
- b) Astrocytes and microglia
- c) Schwann cells and oligodendrocytes

#### Answer

Neurons and glial cells - **This is the correct answer.**

The two major categories of cells found in the nervous system are neurons and glial cells. Neurons are the functional nerve cells directly responsible for transmission of information to and from the CNS to other areas of the body. Glial cells (also known as neuroglia) provide support to the neural tissue, regulate the environment around the neurons, and protect against foreign invaders.

### 3) The propagation of an electrical impulse (action potential) down an axon consists of:

- a) The transmission of the action potential by chemical neurotransmitters
- b) The movement of sodium ions from the dendrite to the axon
- c) A continuous series of opening and closing of sodium-potassium channels and pumps

#### Answer

A continuous series of opening and closing of sodium-potassium channels and pumps - **This is the correct answer.**

The propagation of an electrical impulse (action potential) down an axon consists of a continuous series of opening and closing of sodium-potassium channels and pumps. The action potential moves like a wave from one end (dendritic end) to the terminal end of the axon.

### 4) The type of neuron that relays information from the CNS to other organs is a:

- a) Motor neuron
- b) Sensory neuron
- c) Interneuron

#### Answer

Motor neuron - **This is the correct answer.**

Motor Neurons (effector neurons) relay information from the CNS to other organs terminating at the effectors.

### 5) The primary cause of death to neurons and glial cells is:

- a) Interference with chemical transmission

- b) Interference with electrical transmission
- c) Anoxia

**Answer**

Anoxia - **This is the correct answer.**

The most common cause of death of neurons and glial cells is anoxia, an inadequate oxygen supply to the cells or their inability to utilize oxygen.

## 6) A major mechanism that prevents the action potential (impulse) from moving down an axon is:

- a) Blockage or interference with movement of sodium and potassium ions in and out of neuron membrane, changing the action potential
- b) Excessive release of chemical neurotransmitters
- c) Blocking receptors at the post-synaptic membrane

**Answer**

Blockage or interference with movement of sodium and potassium ions in and out of neuron membrane, changing the action potential - **This is the correct answer.**

Interruption of the propagation of the electrical potential is caused by agents that can block or interfere with the sodium and potassium channels and sodium-potassium pump. This will weaken, slow, or completely interrupt the movement of the electrical potential.

## 7) What are the two basic types of synapses?

- a) Neuro-muscular and neuro-glandular
- b) CNS and PNS synapses
- c) Those between two neurons and a neuron and effector

**Answer**

Those between two neurons and a neuron and effector - **This is the correct answer.**

The two basic types of synapses are those between two neurons and those between a neuron and effectors, such as muscle cell or gland. The major difference in the two basic types is that the neurotransmitting chemical between a neuron and muscle cell is acetylcholine whereas there are several other types of neurotransmitting chemicals involved between neurons, depending on where in the nervous system the synapse is located.

This page titled [14.4: Neurotoxicity](#) is shared under a [CC BY-NC 4.0](#) license and was authored, remixed, and/or curated by [ToxMSDT Online component](#) via [source content](#) that was edited to the style and standards of the LibreTexts platform.

## CHAPTER OVERVIEW

### Section 15: Intuitive Toxicology and Risk Communication

## Learning Objectives

After completing this lesson, you will be able to:

- Describe aspects of Intuitive Toxicology.
- Describe aspects of Risk Communication.

## In this section...

Topics include:

[15.1: Intuitive Toxicology](#)

[15.2: Risk Communication](#)

## Section 15: Key Points

## What We've Covered

This section made the following main points:

- Intuitive toxicology:
  - Combines the intuitive elements of expert and public risk judgments involved with exposure assessment, toxicology, and risk assessment.
  - Asks if toxicologists agree or disagree that an animal's reactions to a chemical reliably predict human reactions.
  - Asks if a chemical found in a scientific study to cause cancer in animals can be reasonably assumed to cause cancer in humans.
- When communicating risk, one needs to:
  - Accept and involve the public as a legitimate partner.
  - Listen to the public's specific concerns.
  - Be honest, frank, and open.
  - Coordinate and collaborate with other credible sources.
  - Meet the needs of the media.
  - Speak clearly and with compassion.
  - Plan carefully and evaluate your efforts.
  - Acknowledge and describe uncertainty, such as any data gaps or issues relating to methodology.

---

This page titled [Section 15: Intuitive Toxicology and Risk Communication](#) is shared under a [CC BY-NC 4.0](#) license and was authored, remixed, and/or curated by [ToxMSDT Online component](#) via [source content](#) that was edited to the style and standards of the LibreTexts platform.

## 15.1: Intuitive Toxicology

### Intuitive Toxicology

**Intuitive** can be defined as "using or based on what one feels to be true even without conscious reasoning." Humans have always been intuitive toxicologists via the use of the senses of sight, taste, and smell to try to detect harmful or unsafe food, water, and air.

### Intuition and Professional Judgment in Toxicology

Even well-established scientific approaches used in human risk assessment depend on extrapolations and judgments when assessing human, animal and other toxicology data. This led to the study of **intuitive toxicology**—the intuitive elements of expert and public risk judgments involved with exposure assessment, toxicology, and risk assessment.

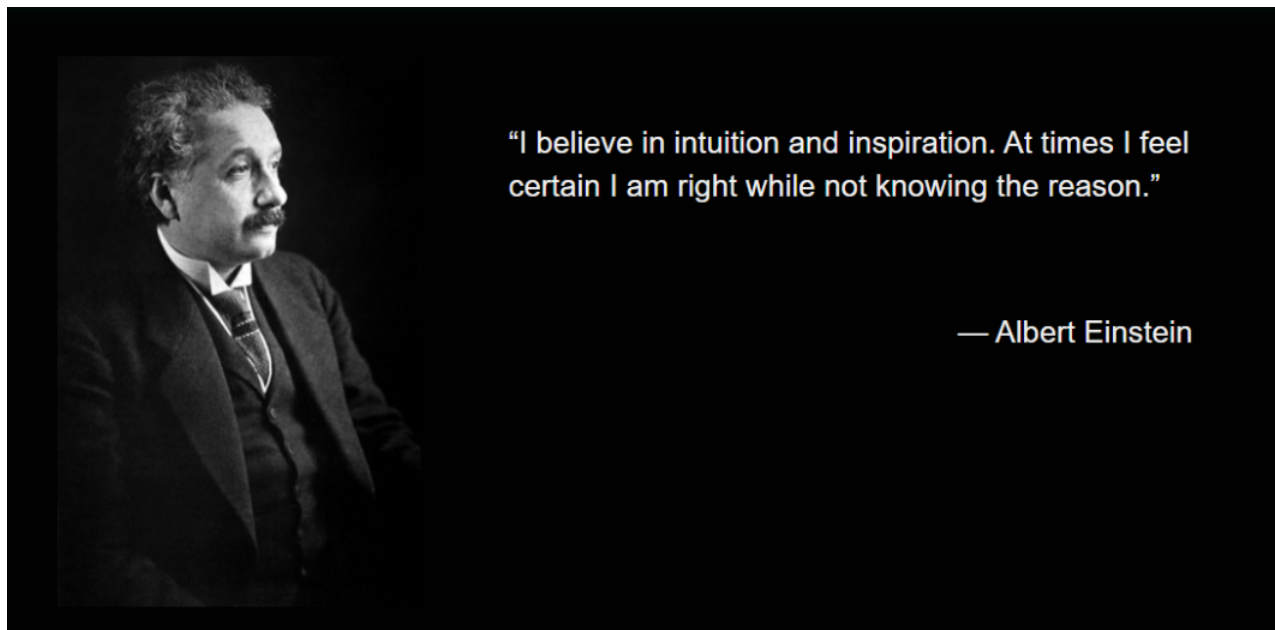

Figure 15.1.1. Albert Einstein understood the importance of intuition along with knowledge and experience (Image Source: Wikimedia Commons, Public Domain - [original image](#))

### Studies of Intuitive Toxicology

The studies of intuitive toxicology have surveyed toxicologists (for example, members of the Society of Toxicology) and others about a wide range of attitudes, beliefs, and perceptions regarding risks from chemicals. These have included basic concepts, assumptions, and interpretations related to the effects of chemical concentration, dose, and exposure on risk, and the value of animal studies for predicting the effects of chemicals on humans.

Two questions that have been studied repeatedly in intuitive toxicology are:

1. Would you agree or disagree that the way an animal reacts to a chemical is a reliable predictor of how a human would react to it?
2. If a scientific study produces evidence that a chemical causes cancer in animals, can we then be reasonably sure that the chemical will cause cancer in humans?

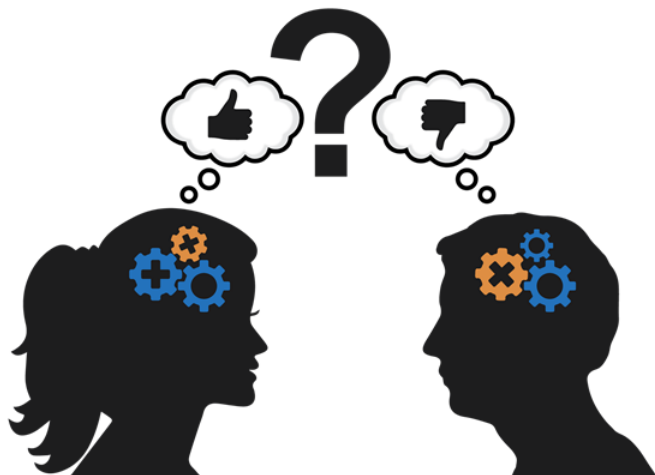

Figure 15.1.2 Understanding and application of toxicology sometimes involves elements of expert judgment and intuition (Image Source: Adapted from iStock Photos, ©)

## Examples of Findings from Intuitive Toxicology

Examples of the findings from studies of intuitive toxicology in the United States, Canada, and the United Kingdom include:

- The public is more likely than toxicologists to think chemicals pose greater risks.
- The public finds it difficult to understand the concept of dose–response relationships.
- Much disagreement between toxicologists about how to interpret various results.
- Technical judgments of toxicologists were also found to be associated with factors such as their type of employment (for example, academia, government, or industry), gender, and age.

These types of studies have identified misconceptions that experts should try to clarify in interactions with the public. The results also suggest that disagreement among experts, especially as perceived by the news media and the public, can play a key role in controversies over toxicology-related risks.

**Learn more** about Intuitive Toxicology

- [Perception of risk.](#)  
Slovic P.  
Science. 1987 Apr 17;236(4799):280-5.
- [Risk perception: it's personal.](#)  
Brown VJ. Environ Health Perspect. 2014 Oct;122(10):A276-9. doi: 10.1289/ehp.122-A276
- [Intuitive toxicology: expert and lay judgments of chemical risks.](#) Neil N, Malmfors T, Slovic P. Toxicol Pathol. 1994 Mar-Apr;22(2):198-201.
- [Judgments of chemical risks: comparisons among senior managers, toxicologists, and the public.](#) Mertz CK, Slovic P, Purchase IF. Risk Anal. 1998 Aug;18(4):391-404.

### Knowledge Check

#### 1) Intuitive toxicology studies show that:

- All toxicologists think the same
- Members of the public usually think like toxicologists
- There can be meaningful differences among toxicologists in how they look at the same set of toxicology study results
- Intuitive toxicology is not important to consider in communication efforts

Answer

There can be meaningful differences among toxicologists in how they look at the same set of toxicology study results -

**This is the correct answer.**

Intuitive toxicology studies show that there can be meaningful differences among toxicologists in how they look at the same set of toxicology study results.

## 2) Which of the following statements is correct?

- a) The concept of dose-response relationships is easily understood by the public
- b) The public and toxicologists tend to agree about the risks of chemicals
- c) Technical judgments of toxicologists have been found to not be associated with factors such as their type of employment (for example, academia, government of industry, gender, and age)
- d) Technical judgments of toxicologists have been found to be associated with factors such as their type of employment (for example, academia, government of industry, gender, and age)

### Answer

Technical judgments of toxicologists have been found to be associated with factors such as their type of employment (for example, academia, government of industry, gender, and age) - **This is the correct answer.**

Technical judgments of toxicologists have been found to be associated with factors such as their type of employment (for example, academia, government of industry, gender, and age).

---

This page titled [15.1: Intuitive Toxicology](#) is shared under a [CC BY-NC 4.0](#) license and was authored, remixed, and/or curated by [ToxMSDT Online component](#) via [source content](#) that was edited to the style and standards of the LibreTexts platform.

## 15.2: Risk Communication

### Risk Communication

Risk communication is the exchange of information about risks.

### Rules for Communicating Risk

Much information about how risks could be communicated is available. Some key points about risk communication are identified in the "[Seven Cardinal Rules for Communicating Risk](#)" from the work of Dr. Vincent Covello and used by U.S. EPA and others:

- Accept and involve the public as a legitimate partner.
- Listen to the public's specific concerns.
- Be honest, frank, and open.
- Coordinate and collaborate with other credible sources.
- Meet the needs of the media.
- Speak clearly and with compassion.
- Plan carefully and evaluate your efforts.

### Lessons Learned About Communicating Risk

Some of the lessons that organizations have learned about communicating exposure and health effects information to study subjects, the community, and the public include:

- Communication is not a "cheap add-on" to a study. It must be planned and budgeted at the start. The researcher must know the community and establish relationships early in the project. Communications should be tailored to the project and should contain what people really need to know. The study results that are most significant for the community should be emphasized. Moreover, results should be communicated in a format and a manner that subjects can readily understand. Researchers should evaluate and learn from each study.
- Ignoring communication may lead to legal problems.
- Communicating risk is part of societal accountability.
- Principles and guidelines, including proper terminology, are needed.
- Guidelines should be enforceable.
- Communication requires resources.
- It should be determined early in the project who has control of the release of results, and whether results will be presented in stages or all at once.
- A professional's credibility is at risk when decisions about communication of study results are being made.
- Mechanisms may be needed to proactively consider communication.
- The role of Institutional Review Boards (IRBs) must be considered in developing communication.

[Learn more](#) about communicating risk

### Lessons Learned from a Crisis and Emergency

Six principles of effective crisis and risk communication are:

1. Be first
2. Be right
3. Be credible
4. Express empathy
5. Promote action
6. Show respect

"The CDC acknowledges that less-than-clear communication about what was known and not known about the possible health effects of the Elk River spill may have affected communities' trust in government." [Learn more](#)



Figure 15.2.1 Charleston, West Virginia viewed from across the Kanawha River, of which the Elk River is a tributary  
(Image Source: iStock Photos, ©)

### Uncertainty

Uncertainty is defined as "imperfect knowledge concerning the present or future state of an organism, system, or (sub)population under consideration." In other sources ([EFSA, 2018](#)), "uncertainty is defined as referring to all types of limitations in the knowledge available to assessors at the time an assessment is conducted and within the time and resources available for the assessment." There are different types of uncertainty, some quantifiable and others not, some reducible and others not.

Due to lack of knowledge, variability adds to the overall uncertainty. Ignoring uncertainty may lead to incomplete risk assessments, poor decision-making, and poor risk communication ([European Commission, 2015](#)). The degree to which characterization of uncertainty (and variability) is needed will depend on the risk assessment and risk management contexts as determined in the questions asked (problem formulation).



Figure 15.2.1 Uncertainty  
(Image Source: Adapted from iStock Photos, ©)

Uncertainty should be acknowledged and described, such as outlining any data gaps or issues relating to methodology. What is being done to address the areas of uncertainty is also important. In its guideline [When Food Is Cooking Up a Storm](#), the European Food Safety Authority provides a framework to assist decision-making about appropriate communications approaches in a wide variety of situations that can occur when assessing and communicating on risks related to food safety in Europe. It is directed towards governmental agencies that regulate the food sector.

EFSA has developed a harmonized approach to assessing and taking account of uncertainties in food safety, and animal and plant health. In 2018, EFSA published its [Guidance on Uncertainty Analysis in Scientific Assessment](#) which offers a diverse toolbox of scientific methods and technical tools for uncertainty analysis. It is sufficiently flexible to be implemented in such diverse areas as plant pests, microbiological hazards and chemical substances. Further, in a separate document EFSA (2018) [describes the principles and methods behind its guidance](#). It provides a flexible framework within which different methods may be selected, according to the needs of each risk assessment. It is recommended that assessors should systematically identify sources of uncertainty, checking each part of their assessment to minimize the risk of overlooking important uncertainties.

## Communicating Uncertainty in Risk Assessments and in Risk Management



Figure 15.2.3 Uncertainty  
(Image Source: Adapted from iStock Photos, ©)

By late 2018, EFSA is expected to have a [practical guidance for communication specialists](#) on how to communicate the results of uncertainty analysis to different target audiences, including the public. The document aims to help EFSA to communicate scientific uncertainties to its different audiences by using more accessible language tailored to their needs.

Learn more about uncertainty and communicating about it

- U.S. FDA: "Elemental Analysis Manual for Food and Related Products" - <https://www.fda.gov/Food/FoodScienceResearch/LaboratoryMethods/ucm2006954.htm>
- U.S. FDA: "Best Practices in Risk Communication and Communicating Uncertainty: Applications to FDA-Regulated Products" - <https://www.fda.gov/downloads/AdvisoryCommittees/CommitteesMeetingMaterials/RiskCommunicationAdvisoryCommittee/UCM486965.pdf>
- EFSA: "[Risk, Precautionary Principle and Uncertainty](#)", European Commission [Uncertainty assessment](#)"
- EFSA: Workshop on the trial of the EFSA guidance document on uncertainty analysis in scientific assessments, 22 - 23 June 2017, Parma, Italy. <https://www.efsa.europa.eu/en/supporting/pub/en-1313>
- EFSA: Member State multilingual online survey on communicating uncertainty to different target audiences. European Food Safety Authority - <http://www.efsa.europa.eu/en/supporting/pub/en-1413>
- EFSA: "[Communicating uncertainty: some applications of indicators and their validity](#)." [PDF]
- EFSA: "[When Food Is Cooking Up a Storm – Proven Recipes for Risk Communications](#)"

### Knowledge Check

#### 1) Which of the following is not true about communicating risk to a community about exposures and health effects?

- Results should be communicated in a format and a manner that subjects can readily understand
- Results do not need to be communicated in a format and a manner that subjects can readily understand
- Communications should be tailored to the project and should contain what people really need to know
- Researchers and others can learn from studying good and bad risk communication efforts

#### Answer

Results do not need to be communicated in a format and a manner that subjects can readily understand - **This is the correct answer.**

#### 2) According to the European Commission, ignoring uncertainty may lead to:

- Great decision-making
- Poor decision-making
- Effective risk communication
- Use of the most accurate knowledge available

#### Answer

Poor decision-making - **This is the correct answer.**

According to the European Commission, ignoring uncertainty may lead to poor decision-making.

This page titled [15.2: Risk Communication](#) is shared under a [CC BY-NC 4.0](#) license and was authored, remixed, and/or curated by [ToxMSDT Online component](#) via [source content](#) that was edited to the style and standards of the LibreTexts platform.



## CHAPTER OVERVIEW

### Section 16: Environmental Toxicology, Environmental Health, and One Health

## Learning Objectives

After completing this lesson, you will be able to:

- Define Environmental Toxicology.
- Describe the differences between environmental toxicology and environmental health.
- Define One Health.

## In this section...

Topics include:

[16.1: Environmental Toxicology](#)

[16.2: Environmental Health](#)

[16.3: One Health](#)

## Section 16: Key Points

## What We've Covered

This section made the following main points:

- Environmental Toxicology:
  - Is the multidisciplinary study of the effects of manmade and natural chemicals on health and the environment.
  - Includes work in academia, companies, government agencies, and elsewhere.
- Environmental Health:
  - Is a branch of public health focused on the relationships between people and their environment.
  - Seeks to advance policies and programs to reduce chemical and other environmental exposures in air, water, soil, and food.
  - Saves lives, saves money, and protects your future.
- One Health:
  - Is a global concept and strategy recognizing the links between the health of people, animals, and the environment.
  - Examines changes in the interactions between people, animals, and the environment and how these changes impact human and animal health.

---

This page titled [Section 16: Environmental Toxicology, Environmental Health, and One Health](#) is shared under a [CC BY-NC 4.0](#) license and was authored, remixed, and/or curated by [ToxMSDT Online component](#) via [source content](#) that was edited to the style and standards of the LibreTexts platform.

## 16.1: Environmental Toxicology

### Environmental Toxicology

Environmental Toxicology is the multidisciplinary study of the effects of manmade and natural chemicals on health and the environment. This includes the study of the effects of chemicals on organisms in their natural environments and in the ecosystems to which they belong.

### Branches of Environmental Toxicology

Environmental Toxicology covers a wide range of interdisciplinary studies, as illustrated in Figure 1:

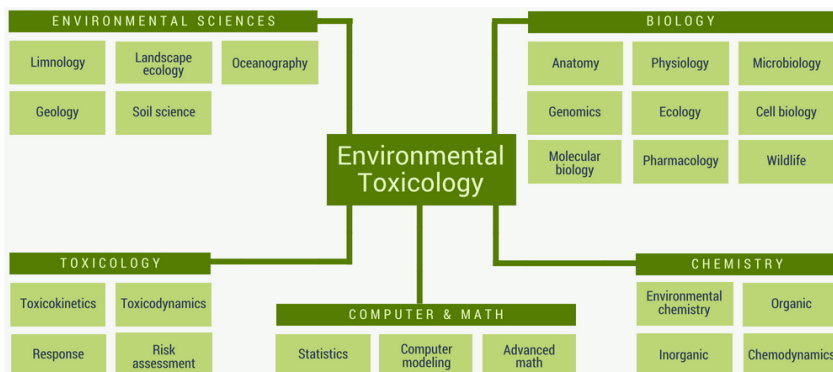

Figure 16.1.1 Environmental Toxicology interdisciplinary core (not comprehensive)  
(Image Source: Adapted from Wikipedia under the Creative Commons Attribution-ShareAlike 3.0 License)

### Scope of Work and Study

Environmental toxicologists work in academia, companies, government agencies, and elsewhere. The work can include laboratory studies, computer modeling, and work "in the field." It is not unusual for an environmental toxicologist to also have training in other areas—for example, public health, environmental chemistry, and pharmacology.

Some examples of what Environmental Toxicologists study include:

- The effects of a chemical or other substance at various concentrations on various species.
- Whether a chemical or other substance can bioaccumulate (increase over time) in animals or other organisms. This is important for human exposures if the bioaccumulation occurs in animals that are part of the human food chain, such as fish.
- Emerging issues such as the study of the sources and effects of microplastics that could become part of the human food chain.

#### Learn more about microplastics

- U.S. EPA "Toxicological Threats of Plastic" - <https://www.epa.gov/trash-free-waters/toxicological-threats-plastic>
- GreenFacts "Marine Litter" - <https://www.greenfacts.org/en/marine-litter/index.htm#1>
- European Chemicals Agency "Microplastics" - <https://echa.europa.eu/hot-topics/microplastics>



Figure 16.1.2 Microplastics are plastic debris less than five millimeters in length  
(Image Source: National Ocean Service, National Oceanic and Atmospheric Administration. [Original image](#))

Another emerging global issue is the health of bees. In the news in recent years are terms like the Colony Collapse Disorder (CCD), pesticides like the neonicotinoid pesticides (also called neonicotinoids), and parasites that only reproduce in bee colonies. About 75% of all flowering plants rely on animal pollinators and about one-third of our food production is dependent on animal pollinators. The general declining health of honeybees and other bees is thought to be related to complex interactions among multiple stressors, including pesticides and parasites, and stressors like poor nutrition due to declining foraging habitats, bee management practices, and a lack of genetic diversity.

Neonicotinoids have been a focus of international attention and their mode of action is on the central nervous system of insects. Neonicotinoids are highly toxic to honeybees and also native bees like bumble bees and blue orchard bees, and sub-lethal levels can affect foraging and the ability to reproduce. Further, neonicotinoids can be persistent in the environment, and can be absorbed by plants and found in pollen and nectar.

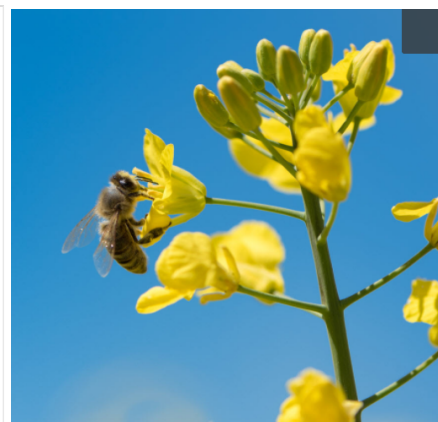

Figure 16.1.3 A honeybee gathers pollen from a flower  
(Image Source: iStock Photos, ©)

#### Learn more about pollinators

- U.S. Fish and Wildlife Service "Pollinators" - <https://www.fws.gov/Pollinators/>
- U.S. Department of Agriculture, Forest Service "Pollinators" - <https://www.fs.fed.us/wildflowers/pollinators/index.shtml>
- U.S. EPA "Pollinator Health Concerns" - <https://www.epa.gov/pollinator-protection/pollinator-health-concerns>
- European Commission "The EU Approach to Tackle Pollinator Decline" - [http://ec.europa.eu/environment/nature/conservation/species/pollinators/index\\_en.htm](http://ec.europa.eu/environment/nature/conservation/species/pollinators/index_en.htm)
- European Food Safety Authority "Bees Under Siege: Making Sense of Multiple Stressors" - <https://www.youtube.com/watch?v=ZVKJNc0tBDM&feature=youtu.be&list=PLGDygn1aAEEbWUxOz08fjrtBQpLiC5DOB>
- Xerces Society for Invertebrate Conservation "Neonicotinoids and Bees" - <http://xerces.org/neonicotinoids-and-bees/>

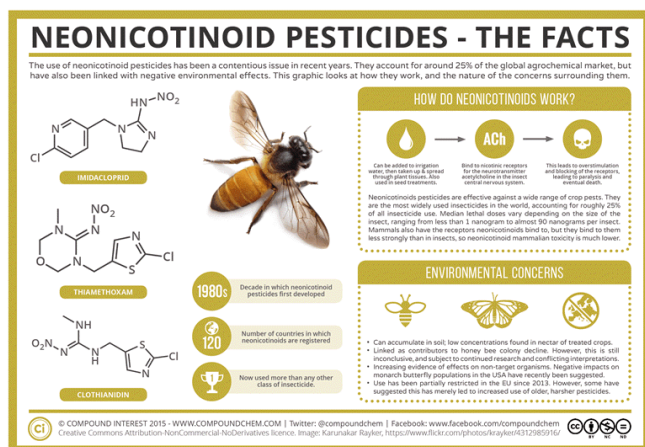

Figure 16.1.4 Neonicotinoid Pesticides

(Image Source: Compound Interest, © 2015 - used under Creative Commons Attribution-NonCommercial-NoDerivatives license. Bee image captured by Karunakar Rayker. [Original Image](#), [Original Infographic](#))

#### Knowledge Check

##### 1) The interdisciplinary core ("branches") of environmental toxicology includes:

- Environmental sciences; physics; toxicology; chemistry; biology
- Environmental sciences; engineering; toxicology; biology; computer and math
- Environmental sciences; computer and math; toxicology; biology; law
- Environmental sciences; biology; toxicology; chemistry; computer and math

##### Answer

Environmental sciences; biology; toxicology; chemistry; computer and math - **This is the correct answer.**

The interdisciplinary core ("branches") of environmental toxicology includes environmental sciences; biology; toxicology; chemistry; computer and math.

##### 2) Which issues in environmental toxicology relate to the human food supply?

- Bioaccumulation of substances in fish
- Effects of neonicotinic pesticides on bees
- Both the bioaccumulation of substances in fish and effects of neonicotinic pesticides on bees

##### Answer

Both the bioaccumulation of substances in fish and effects of neonicotinic pesticides on bees - **This is the correct answer.**

Both the bioaccumulation of substances in fish and effects of neonicotinic pesticides on bees relate to the human food supply.

This page titled [16.1: Environmental Toxicology](#) is shared under a [CC BY-NC 4.0](#) license and was authored, remixed, and/or curated by [ToxMSDT Online component](#) via [source content](#) that was edited to the style and standards of the LibreTexts platform.

## 16.2: Environmental Health

### Environmental Health

Environmental health is a branch of public health. It focuses on the relationships between people and their environment, and promotes human health and well-being. Further, it fosters healthy and safe communities and is a key part of any comprehensive public health system. The field works to advance policies and programs to reduce chemical and other environmental exposures in air, water, soil, and food to protect people and provide communities with an healthier environments.

### Toxicology vs. Environmental Health

The two fields are closely connected, with a large intersection.

The terminology is loose. For example, is environmental health about the health of the environment and/or the effect of the environment on health?

### Scope of Work and Study

Environmental health specialists identify and evaluate environmental hazards and their sources. They also limit exposures to physical, chemical, and biological agents in air, water, soil, food, and other environmental media or settings that may adversely affect human health ([Source](#)).



Figure 16.2.1 Environmental health saves lives, saves money, and protects your future (Image Source: National Environmental Health Association (NEHA), © 2016. [Original image](#))

## National Center for Environmental Health (NCEH)

The CDC National Center for Environmental Health (NCEH) plans, directs, and coordinates a program to protect the American people from environmental hazards. The NCEH seeks to prevent premature death, avoidable illness, and disability caused by non-infectious, non-occupational environmental and related factors. One focus is on safeguarding the health of venerable populations, such as children, the elderly, and people with disabilities, from certain environmental hazards.

**Learn more** about environmental health

- U.S. CDC National Center for Environmental Health - <https://www.cdc.gov/nceh/>
- American Public Health Association (APHA): "Environmental Health" - <https://www.apha.org/topics-and-issues/environmental-health>
- National Environmental Health Association (NEHA): "Definitions of Environmental Health" - <https://www.neha.org/about-neha/definitions-environmental-health>

### Knowledge Check

#### 1) Which of the following are important environmental health issues?

- a) Radon in air
- b) Lead contamination in drinking water
- c) Foodborne illness from contaminated food
- d) All of these are important for human health

#### Answer

All of these are important for human health

This page titled [16.2: Environmental Health](#) is shared under a [CC BY-NC 4.0](#) license and was authored, remixed, and/or curated by [ToxMSDT Online component](#) via [source content](#) that was edited to the style and standards of the LibreTexts platform.

## 16.3: One Health

### One Health

One Health is a worldwide concept and strategy recognizing that the health of people, animals, and the environment are all connected. For example, the Centers for Disease Control and Prevention (CDC) works with physicians, veterinarians, ecologists, and many others to monitor and control public health threats and to learn about how diseases spread among people, animals, and the environment.

## Link Between Human, Animal, and Environmental Health

One Health is important at the local, regional, national, and global levels, and there are many examples of its importance. One example of how human, animal, and environmental health are linked involves bacteria, cows, farms, food, lettuce, and humans:

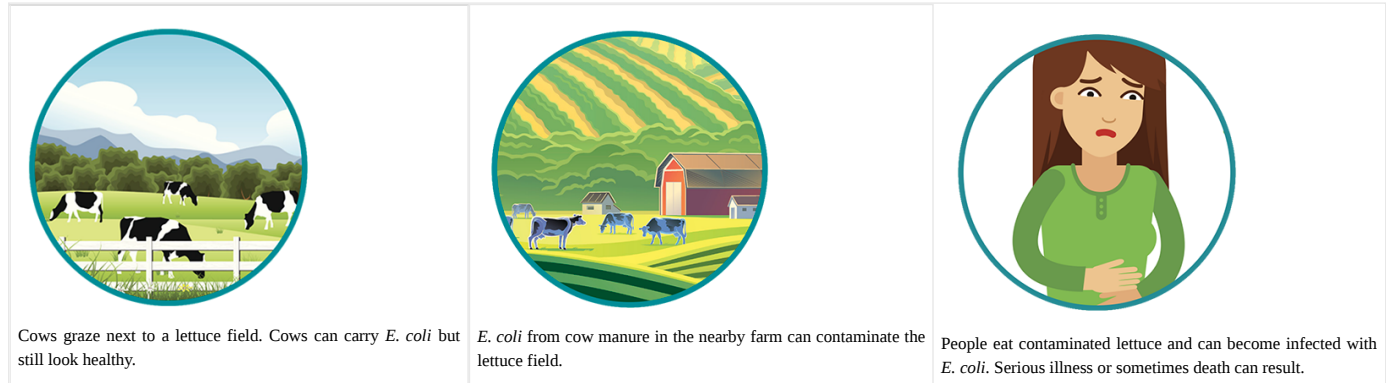

Figure 16.3.1 Human, animal, and environmental health are linked  
(Image Source: CDC - [original image](#))

Another example of One Health involving animals and humans is the shared susceptibility to some diseases and environmental hazards. Animals can serve as early warning signs of potential human illness. An example is birds dying from West Nile virus before people in the same areas get sick from exposures to this virus.

## Factors that Affect Human and Animal Health

Some interactions between people, animals, and the environment have changed in recent years and these changes have impacted animal and human health.

Factor (Cause)	Change (Effect)
Human populations are growing and expanding into new geographic areas.	More people live in close contact with wild and domestic animals. Close contact provides more opportunities for diseases to pass between animals and people.
The earth has experienced changes in climate and land use, such as deforestation and intensive farming practices.	Disruptions in environmental conditions and habitats provide new opportunities for diseases to pass to animals.
International travel and trade have increased.	Diseases can spread quickly across the globe.

Table 16.3.1 Factors that affect human and animal health  
(Source: [CDC: One Health Basics](#))

### Learn more about One Health

- U.S. CDC: "One Health: From Concept to Action" - <https://youtu.be/TG0pduAYESA>
- U.S. CDC: "One Health Basics" - <https://www.cdc.gov/onehealth/basics/index.html>
- World Organization for Animal Health (OIE): "One Health: By Protecting Animals, We Preserve Our Future [PDF]" - [http://www.oie.int/fileadmin/Home/eng/Media\\_Center/img/Infographies/A4-EN-WEB.pdf](http://www.oie.int/fileadmin/Home/eng/Media_Center/img/Infographies/A4-EN-WEB.pdf)
- U.S. FDA: "One Health: It's for All of Us" - <https://www.fda.gov/AnimalVeterinary/ResourcesforYou/AnimalHealthLiteracy/ucm278139.htm>

### Knowledge Check

1) One Health is a concept and strategy recognizing that the health of \_\_\_\_\_, \_\_\_\_\_, and \_\_\_\_\_ are all connected.

- People, plants, the environment
- People, animals, the environment
- People, animals, microbes

#### Answer

People, animals, the environment - **This is the correct answer.**

One Health is a concept and strategy recognizing that the health of people, animals, and the environment are all connected.

2) Which of the following factors that affect human and animal health is not correct?

- Fewer people in recent years live in close contact with wild and domestic animals

- b) Disruptions in environmental conditions and habitats provide new opportunities for diseases to pass to animals
- c) International travel and trade have increased, and diseases can spread quickly across the globe

**Answer**

Fewer people in recent years live in close contact with wild and domestic animals - **This is the correct answer.**  
The statement "Fewer people in recent years live in close contact with wild and domestic animals" is incorrect.

This page titled [16.3: One Health](#) is shared under a [CC BY-NC 4.0](#) license and was authored, remixed, and/or curated by [ToxMSDT Online component](#) via [source content](#) that was edited to the style and standards of the LibreTexts platform.



## Section 17: Conclusion

---

**Thank you for completing ToxTutor!** We trust it has given you a strong foundation of understanding in this important area of science.

In conclusion, we have now covered the following topics throughout this course:

1. Introduction to Toxicology
2. Dose and Dose Response
3. Toxic Effects
4. Interactions
5. Toxicity Testing Methods
6. Risk Assessment
7. Exposure Standards and Guidelines
8. Basic Physiology
9. Introduction to Toxicokinetics
10. Absorption
11. Distribution
12. Biotransformation
13. Excretion
14. Cellular Toxicology
15. Intuitive Toxicology and Risk Communication
16. Environmental Toxicology, Environmental Health, and One Health

## Contact Information

If you would like additional information about toxicology and environmental health, or if you have any questions or comments, please contact us at [toxmsdt@gmail.com](mailto:toxmsdt@gmail.com)

## Credits

ToxTutor was adopted from the [U.S National Library of Medicine](#) in 2021. More Information can be seen in the [ToxTutor Bibliography](#).



This page titled [Section 17: Conclusion](#) is shared under a [CC BY-NC 4.0](#) license and was authored, remixed, and/or curated by [ToxMSDT Online component](#) via [source content](#) that was edited to the style and standards of the LibreTexts platform.

## CHAPTER OVERVIEW

### Section 2: Dose and Dose Response

#### Learning Objectives

After completing this lesson, you will be able to:

- Define *dose* and explain its importance in determining toxicity.
- Analyze and compare dose-response curves.
- Describe the safety or toxicity of substances based on specific dose levels.

#### In this section...

Topics include:

[2.1: Dose and It's Impact on Toxicity](#)

[2.2: The Dose Response Relationship](#)

[2.3: Dose Estimates of Toxic Effects](#)

[2.4: Determining the Safety of a Drug](#)

[2.5: NOAEL and LOAEL](#)

#### What We've Covered

In this section, we explored the following main points:

- Dose is the amount of a substance administered; however, several parameters are required to characterize exposure to xenobiotics, including the:
  - Number of doses
  - Frequency of doses
  - Total time period of exposure
- The dose-response relationship helps establish causality, or that the chemical induced the observed effects; the threshold effect, or the lowest dose that induced effects; and the slope, or the rate at which effects increase with dose increases.
- Estimating doses for toxic effects involves:
  - Lethal Doses/Concentrations, such as LD0, LD10, and LC50, which denote doses or concentrations that are expected to lead to death in specific percentages of a population.
  - Effective Doses, such as ED50 and ED90, which denote doses that are effective in achieving a desired endpoint in specific percentages of a population.
  - Toxic Doses, such as TD0 and TD50, which denote doses that cause adverse toxic effects in specific percentages of a population.
- The Therapeutic Index (TI) compares the effective dose to the toxic dose of a drug.
- The Margin of Safety (MOS) compares the toxic dose to 1% of the population to the effective dose to 99% of the population.
- NOAEL is the **highest** dose at which there **is no** observed toxic effect.
- LOAEL is the **lowest** dose at which there **is** an observed toxic effect.

#### Coming Up...

In the next section, we will take a closer look at various types of toxic effects.

---

This page titled [Section 2: Dose and Dose Response](#) is shared under a [CC BY-NC 4.0](#) license and was authored, remixed, and/or curated by [ToxMSDT Online component](#) via [source content](#) that was edited to the style and standards of the LibreTexts platform.

## 2.1: Dose and Its Impact on Toxicity

### Dose Defined

**Dose** by definition is the amount of a substance administered at one time. However, other parameters are needed to characterize the exposure to xenobiotics. The most important are the number of doses, frequency, and total time period of the treatment.

For example:

- 650 -3 g). " tabindex="0">mg acetaminophen (Tylenol® products) as a single dose.
- 500 -3 g). " tabindex="0">mg penicillin every 8 hours for 10 days.
- 10 -3 g). " tabindex="0">mg DDT per day for 90 days.

Substances can enter the body from either:

1. Encountering them in the environment (**exposure**).
2. Intentionally consuming or administering a certain quantity of a substance.

Environments in which xenobiotics are present include outdoor air, indoor air, and water. Xenobiotics can travel into the body through the skin, eyes, lungs, and digestive tract. **Exposure to a xenobiotic** can occur in any environment where a substance can enter the:

- Skin through dermal absorption (air and water).
- Respiratory tract through inhalation.
- Digestive tract through ingestion.



Figure 2.1.1: Dermal  
(Image Source: ORAU, ©)



Figure 2.1.2: *Inhalation*  
(Image Source: ORAU, ©)



Figure 2.1.3: *Ingestion*  
(Image Source: ORAU, ©)

A dose can be considered either:

1. A measurement of environmental exposures.
2. The amount of a substance administered over a period of time.

Types of doses include:

- **Absorbed dose** — the amount of a substance that entered the body through the skin, eyes, lungs, or digestive tract and was taken up by organs or particular tissues. Absorbed dose can also be called **internal dose**.
- **Administered dose** — the quantity administered usually orally or by injection (note that an administered dose taken orally may not necessarily be absorbed).
- **Total dose** — the sum of all individual doses.

Not all substances that enter the body are necessarily absorbed by it. This concept applies to water intake. When a person drinks a large quantity of water at one time, some of it is absorbed while the rest of the water is eliminated.

If an individual drinks 1 liter of water every hour for 3 hours, each *administered dose* would be 1 liter. The *total dose* would be the amount the person drank over the time period that the water was consumed. The *absorbed dose*, however, would likely be less than the total dose because it would depend on how much of the water the individual's body absorbed which can be affected by various factors. The water intake example is represented in Table 1.

Doses	Administered Dose	Total Dose	Absorbed Dose

Dose 1 (8:00 a.m.): 1 L water	1 L	1 L	Less than 1 L
Dose 2 (9:00 a.m.): 1 L water	1 L	2 L	Less than 2 L
Dose 3 (10:00 a.m.): 1 L water	1 L	3 L	Less than 3 L

The terms for types of doses help account for the amount of a substance that entered the body by different means, but the amount *absorbed* is what is most important.

In a later section, we will review specifics about how the body handles substances after they enter the body.

## Fractionating Doses

**Fractionating** a total dose usually decreases the probability that the total dose will cause toxicity. The reason is that the body often can repair the effect of each **subtoxic** dose if sufficient time elapses before the next dose is received. In that case, a total dose that would be harmful if received all at once is non-toxic when administered over a period of time. For example, 30 -3 g)." tabindex="0">mg of strychnine swallowed at one time could be fatal to an adult whereas 3 -3 g)." tabindex="0">mg of strychnine swallowed each day for 10 days is not considered a fatal dose.

The **units** used in toxicology are basically the same as those used in medicine. The **gram (g)** is the standard unit. Because most exposures are in smaller quantities, the -3 g)." tabindex="0">**milligram (-3 g)." tabindex="0">mg)** is commonly used. For example, the common adult dose of acetaminophen is 650 -3 g)." tabindex="0">mg.

## Importance of Age, Body Size, and Time

A person's age and body size affect the clinical and toxic effects of a given dose. Age and body size usually are connected, particularly in children. This relationship is important because a person's body size can affect the burden that a substance has on it. For example, a 650--3 g)." tabindex="0">mg dose of acetaminophen is typical for adults but it would be toxic to young children. Therefore, a tablet of an acetaminophen product designed for children (Children's Tylenol®) contains only 80 -3 g)." tabindex="0">mg of the drug.

 Stick figure humans of various ages and body sizes gathered around a clock

Figure 2.1.4: Age, body size, and time are key factors when considering the clinical and toxic effects of a dose (Image Source: iStock Photos, ©)

One way to compare the effectiveness of a dose and its toxicity is to assess the amount of a substance administered with respect to **body weight**. A common dose measurement is **mg/kg** which stands for -3 g)." tabindex="0">mg of substance per kg of body weight. Another method used to compare doses among different species is to use **body surface area**, rather than simply body weight.

## Units

Because some xenobiotics are toxic in quantities much smaller than the -3 g)." tabindex="0">milligram, smaller fractions of the gram, such as -6) of a gram." tabindex="0">**microgram (µg)**. Table 2 shows other units.

Unit	Gram Equivalents	Exp. Form
<b>Kilogram (kg)</b>	1000.0 g	$10^3$ g
<b>Gram (g)</b>	1.0 g	1 g
<b>-3 g)." tabindex="0"&gt;Milligram (-3 g)." tabindex="0"&gt;mg)</b>	0.001 g	$10^{-3}$ g
<b>-6) of a gram." tabindex="0"&gt;Microgram (µg)</b>	0.000,001 g	$10^{-6}$ g
<b>-9 g)." tabindex="0"&gt;Nanogram (-9 g)." tabindex="0"&gt;ng)</b>	0.000,000,001 g	$10^{-9}$ g

-12 g)." tabindex="0">Picogram (-12 g)." tabindex="0">pg)	0.000,000,000,001 g	10 <sup>-12</sup> g
Femtogram (fg)	0.000,000,000,000,001 g	10 <sup>-15</sup> g

Table 2.1.1: Various units, their gram equivalents, and their exponential form

## Concentration

**Environmental exposure units** are expressed as the amount of a xenobiotic in a unit of the media, which could be liquid, solid, or air. **Concentration** is the amount of a substance found in a certain amount of another substance, such as water, air, soil, food, blood, hair, urine, or breath. For example, the weight of a toxic substance found in a certain weight of food is indicated as a measure of concentration rather than the total amount. Knowing how concentrated the toxic substance is in a sample of food that weighs 100 g allows for easy comparison when testing for that toxic substance in other samples of food that weigh more or less than 100 g.

Figure 7 illustrates this concept. The two glasses contain samples of juice that are being tested for contamination with lead. The volume of juice in Glass A is 100 mL and the volume of juice in Glass B is 50 mL. The concentration of lead is the same in both samples of juice: 20 parts per billion (ppb). The total amount of lead would be higher in Glass A but the concentration of lead per unit volume is the same in both glasses.

Two glasses of juice, one containing 100 mL and the other containing 50 mL. Both glasses contain a concentration of 20 ppb lead.

Figure 2.1.5: The concentration of lead is the same in samples with different volumes, but the total amount of lead in each is not (Image Source: Adapted from iStock Photos, ©)

## Assessing Exposure

An individual's exposure to a substance can be assessed based on the relationship between the person's *body weight* and these factors:

- *Concentration* of the substance in the environmental media (for example, in µg/ml).
- Amount of the substance taken into the body.
- Duration and frequency of individual events during which the body was in contact with the environmental media.

Environmental exposure units used in toxicology include:

- -3 g)." tabindex="0">mg/liter (-3 g)." tabindex="0">mg/L) for liquids.
- -3 g)." tabindex="0">mg/gram (-3 g)." tabindex="0">mg/g) for solids.
- -3 g)." tabindex="0">mg/cubic meter (-3 g)." tabindex="0">mg/m<sup>3</sup>) for air.

Smaller units are used as needed; for example, -6) of a gram." tabindex="0">µg/mL. Other commonly used dose units for substances in media are parts per million (**ppm**), parts per billion (**ppb**), and parts per trillion (**ppt**). When smaller units are used to quantify exposure, the mg/kg/day unit can be adapted to the smaller unit. For example, parts per billion per kg per day (ppb/kg/day) could be used.

An important thing to remember is that the use of a small dose unit is *not* related to the burden a substance has on the body. An exposure unit describes only the *quantity* of the substance.

This page titled [2.1: Dose and It's Impact on Toxicity](#) is shared under a [CC BY-NC 4.0](#) license and was authored, remixed, and/or curated by [ToxMSDT Online component](#) via [source content](#) that was edited to the style and standards of the LibreTexts platform.

## 2.2: The Dose Response Relationship

### The Dose-Response Relationship

The dose-response relationship is an essential concept in toxicology. It correlates exposures with changes in body functions or health.

In general, the higher the dose, the more severe the response. The dose-response relationship is based on observed data from experimental animal, human clinical, or cell studies.

Knowledge of the dose-response relationship establishes:

- **Causality** — that the chemical has induced the observed effects.
- The **threshold effect** — the lowest dose where an induced effect occurs.
- The **slope** for the dose response — the *rate* at which injury builds up.

Within a population, the majority of responses to a toxicant are similar; however, there are differences in how responses may be encountered – some individuals are susceptible and others resistant. As demonstrated in Animation 1, a graph of the individual responses can be depicted as a bell-shaped standard distribution curve. There is a wide variance in responses as demonstrated by the mild reaction in resistant individuals, the typical response in the majority of individuals, and the severe reaction in sensitive individuals.

*Animation 1: A graph of individual responses to a substance, which generally take the form of a bell-shaped curve ([view full-text, PDF version](#))*

The **dose-response curve** is a visual representation of the response rates of a population to a range of doses of a substance, as demonstrated in Animation 2 (available at [ToxTutor](#)). *The graph of a dose-response relationship typically has an "s" shape. ([view full-text, PDF version](#))*

#### Knowledge Check

1. The quantity of a substance administered to an individual over a period of time or in several individual doses is known as the:

- administered dose
- absorbed dose
- total dose

#### Answer

total dose

It is the quantity of a substance administered to an individual over a period of time or in several individual doses. It is particularly important when evaluating cumulative poisons.

2. Fractionation of a total dose so that the total amount administered is given over a period of time usually results in:

- decreased toxicity
- increased toxicity

#### Answer

decreased

toxicity

Fractionation of a total dose so that the total amount administered is given over a period of time usually results in **decreased toxicity**. This applies to most forms of toxicity but not necessarily to carcinogenicity or mutagenicity.

3. The usual dosage unit that incorporates the amount of material administered or absorbed in accordance with the size of the individual over a period of time is:

- PPM/hour
- mg/kg/day
- kg/100 lb/week

**Answer**

mg/kg/day

The usual dosage unit that incorporates the amount of material administered or absorbed in accordance with the size of the individual over a period of time is **mg/kg/day**. In some cases, much smaller dosage units, such as  $\mu\text{g}/\text{kg}/\text{day}$ , are used.

4. The dose at which a toxic effect is first encountered is called the:

- median toxic dose
- absorbed dose
- threshold dose

**Answer**

threshold dose

5. The dose-response relationship helps a toxicologist determine:

- whether exposure has caused an effect
- the threshold dose
- the rate of increasing effect with increasing dose levels
- all of the above

**Answer**

all of the above

The dose-response relationship demonstrates whether any effect has occurred, the threshold dose, and the rate at which the effect increases with increasing dose levels.

This page titled [2.2: The Dose Response Relationship](#) is shared under a [CC BY-NC 4.0](#) license and was authored, remixed, and/or curated by [ToxMSDT Online component](#) via [source content](#) that was edited to the style and standards of the LibreTexts platform.

## 2.3: Dose Estimates of Toxic Effects

### Dose Estimates

Dose-response curves are used to derive dose estimates of chemical substances.

Historically, **LD50** (Lethal Dose 50%) has been a common dose estimate for acute toxicity. It is a **statistically derived maximum dose** at which 50% of the group of organisms (rat, mouse, or other species) would be expected to die. LD50 testing is no longer the recommended method for assessing toxicity because of the ethics of using large numbers of animals, the variability of responses in animals and humans, and the use of mortality as the only endpoint. Regulatory agencies use LD50 only if it is justified by scientific necessity and ethical considerations.

### The Three Rs

The current practice for estimating acute toxicity emphasizes the following approaches, known as the Three Rs:

1. **Replacing** animals in science by *in vitro*, *in silico*, and other approaches.
2. **Reducing** the number of animals used. For example, the oral LD50 approach has been replaced in some circumstances by an **up-and-down method** in which animals are dosed one at a time.
3. **Refining** care and procedures to minimize pain and distress.

Other dose estimates also may be used.

### Lethal Doses/Concentrations

- **Lethal Dose 0% (LD0)** — represents the dose at which no individuals are expected to die. This is just below the threshold for lethality.
- **Lethal Dose 10% (LD10)** — refers to the dose at which 10% of the individuals will die.
- **Lethal Concentration 50% (LC50)** — for inhalation toxicity, air concentrations are used for exposure values. The LC50 refers to the calculated concentration of a gas lethal to 50% of a group. Occasionally LC0 and LC10 are also used.

### Effective Doses (EDs)

**Effective Doses (EDs)** are used to indicate the effectiveness of a substance. Normally, effective dose refers to a beneficial effect such as relief of pain. It may also stand for a harmful effect such as paralysis. Thus, the specific endpoint must be indicated. The usual terms are:

Term	Effective for this percentage of the population
<b>ED0</b>	0%
<b>ED10</b>	10%
<b>ED50</b>	50%
<b>ED90</b>	90%

Table 2.3.1. Typical terms for describing effective doses

### Toxic Doses (TDs)

**Toxic Doses (TDs)** are used to indicate doses that cause adverse toxic effects. The usual dose estimates include:

Term	Toxic to this percentage of the population
<b>TD0</b>	0%
<b>TD10</b>	10%
<b>TD50</b>	50%
<b>TD90</b>	90%



### Table 2.3.2. Typical terms for describing toxic doses

#### Determining the Relative Safety of Pharmaceuticals

Toxicologists, pharmacologists, and others use **effective** and **toxic dose** levels to determine the relative safety of pharmaceuticals. As shown in Figure 1, two dose-response curves are presented for the same drug, one for effectiveness and the other for toxicity. In this case, a dose that is 50% to 75% effective does not cause toxicity. However, a 90% effective dose may result in a small amount of toxicity.

Graph of two dose-response curves for the same drug - one for effectiveness and one for toxicity. ED10, ED50, ED90, TD10, TD50, TD90 are marked on the graph. A 50-75% effective dose does not cause toxicity in this example, but a 90% effective dose could result in a small amount of toxicity.

Figure 2.3.1. Dose-response curves representing effective dose and toxic dose for the same drug  
(Image Source: NLM)

It should be noted that a desired effect in a drug is often an undesired effect with an environmental chemical.

---

This page titled [2.3: Dose Estimates of Toxic Effects](#) is shared under a [CC BY-NC 4.0](#) license and was authored, remixed, and/or curated by [ToxMSDT Online component](#) via [source content](#) that was edited to the style and standards of the LibreTexts platform.

## 2.4: Determining the Safety of a Drug

### Do you know?

What are measures for describing the safety of a drug? This section describes the:

- Therapeutic index
- Margin of safety

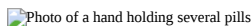

Figure 2.4.1: (Image Source: iStock Photos, ©)

### Therapeutic Index

The **Therapeutic Index (TI)** is used to compare the therapeutically effective dose to the toxic dose of a pharmaceutical agent. The TI is a statement of relative safety of a drug. It is the ratio of the dose that produces toxicity to the dose needed to produce the desired therapeutic response. The common method used to derive the TI is to use the 50% dose-response points, including TD50 (toxic dose) and ED50 (effective dose).



For example, if the TD50 is 200 and the ED50 is 20 -3 g)." tabindex="0">mg, the TI would be 10.

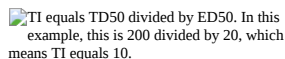

Figure 1).



Figure 2.4.2. A higher value on the Therapeutic Index indicates a more favorable safety profile

(Image Source: ORAU, ©)

However, the use of the **ED50** and **TD50** doses to derive the **TI** may be misleading about a drug's safety, depending on the slope of the dose-response curves for therapeutic and toxic effects. To overcome this deficiency, toxicologists often use another term to denote the safety of a drug: the Margin of Safety.

### Margin of Safety (MOS)

The **Margin of Safety (MOS)** is usually calculated as the ratio of the toxic dose to 1% of the population (TD01) to the dose that is 99% effective to the population (ED99).

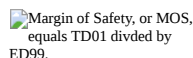

Figure 2 shows the relationship between effective dose response and toxic dose response. The shaded area represents the doses at which the substance produces an effective dose response while the toxic dose response remains below the TD50. The slope of a curve shows how dose increases result in responses to the effective or toxic dose.



Figure 2.4.3. Relationship between effective dose response and toxic dose response

(Image Source: NLM)

Because of differences in slopes and threshold doses, low doses may be effective without producing toxicity. Although more patients may benefit from higher doses, that is offset by the probability that toxicity will occur.

The toxicity of various substances can be compared using the slopes for each curve (Figure 3).



Figure 2.4.4. Comparison of the toxicity of two substances

(Image Source: NLM)

For some substances, a small increase in dose causes a large increase in response, which is seen in Toxicant A's steep slope. For other substances, a much larger increase in dose is required to cause the same increase in response, as indicated in Toxicant B's shallow slope.

---

This page titled [2.4: Determining the Safety of a Drug](#) is shared under a [CC BY-NC 4.0](#) license and was authored, remixed, and/or curated by [ToxMSDT Online component](#) via [source content](#) that was edited to the style and standards of the LibreTexts platform.

## 2.5: NOAEL and LOAEL

### NOAEL and LOAEL

Results from research studies establish the highest doses at which no toxic effects were identified and the lowest doses at which toxic or adverse effects were observed. The terms often used to describe these outcomes are:

- **No Observed Adverse Effect Level (NOAEL)**
- **Lowest Observed Adverse Effect Level (LOAEL)**

These terms refer to the actual doses used in human clinical or experimental animal studies. They are defined as follows:

- NOAEL — *Highest dose* at which there was *not* an observed toxic or adverse effect.
- LOAEL — *Lowest dose* at which there was an observed toxic or adverse effect.

Figure 1 shows a dose-response curve where the NOAEL occurs at 10 mg and the LOAEL occurs at 18 mg.



Figure 2.5.1. A dose-response curve showing doses where the NOAEL and LOAEL occur for a substance (Image Source: NLM)

Sometimes the terms **No Observed Effect Level (NOEL)** and **Lowest Observed Effect Level (LOEL)** are also used. NOELs and LOELs do not necessarily imply toxic or harmful effects and can be used to describe beneficial effects of substances.

The NOAEL, LOAEL, NOEL, and LOEL are commonly used in risk assessments and research. For example, [this U.S. Food and Drug Administration \(FDA\) publication](#) for industry describes a process for estimating the maximum safe starting dose of drugs tested in clinical trials. It provides extensive information about these concepts and their utility when developing new drugs.

NOELs and LOELs are also included in the **Noncarcinogenic Risk Assessment section** where they are applied using the benchmark dose (BMD) method.

#### Knowledge Check

1. Which of the following is **not** one of the Three Rs of estimating acute toxicity?

- Replace animals in science by *in vitro*, *in silico*, and other approaches
- Reduce the number of animals used
- Refine care and procedures to minimize pain and distress
- Randomize the selected test animals

#### Answer

Randomize the selected test animals

The Three Rs involve replacing animals in science by *in vitro*, *in silico*, and other approaches; reducing the number of animals used in testing; and refining care and procedures to minimize pain and distress.

2.

The Therapeutic Index (TI) is used to:

- Compare the therapeutically effective dose to the toxic dose of a pharmaceutical agent
- Calculate the lethal dose level for different pharmaceuticals
- Compare the lethal dose to the therapeutically effective dose of a pharmaceutical agent

#### Answer

Compare the therapeutically effective dose to the toxic dose of a pharmaceutical **agent**

3. The Margin of Safety (MOS) of a drug is the:

- Amount of a pharmaceutical that can be given before toxicity first appears
- Difference between the Effective Dose to 50% of the population (ED50) and the Toxic Dose to 50% of the population (TD50)
- Ratio of the Toxic Dose to 1% of the population (TD01) to the Effective Dose to 99% of the population (ED99)

**Answer**

- Ratio of the Toxic Dose to 1% of the population (TD01) to the Effective Dose to 99% of the population (ED99)

4. The No Observed Adverse Effect Level (NOAEL) is the:

- Lowest dose* at which there was *no* observed toxic or adverse effect
- Highest dose* at which there was *no* observed toxic or adverse effect
- Highest dose* at which there was an observed adverse effect

**Answer**

*Highest dose* at which there was *no* observed toxic or adverse effect

5. The Lowest Observed Adverse Effect Level (LOAEL) is the:

- Lowest dose* at which there was an observed toxic or adverse effect
- Lowest dose* at which there was *no* observed toxic or adverse effect
- Highest dose* at which there was an observed adverse effect

**Answer**

*Lowest dose* at which there was an observed toxic or adverse effect

This page titled [2.5: NOAEL and LOAEL](#) is shared under a [CC BY-NC 4.0](#) license and was authored, remixed, and/or curated by [ToxMSDT Online component](#) via [source content](#) that was edited to the style and standards of the LibreTexts platform.

## CHAPTER OVERVIEW

### Section 3: Toxic Effects

#### Learning Objectives

After completing this lesson, you will be able to:

- Explain factors that influence the toxicity of a substance.
- Define types of systemic and organ-specific toxic effects.

#### In this section...

Topics include:

- 3.1: Types of Toxic Effects
- 3.2: Factors Affecting Toxicity
- 3.3: Systemic Toxic Effects
- 3.4: Organ Specific Toxic Effects

#### Did you know?

In December 1984, the world's worst industrial accident occurred in Bhopal, India. More than 40 tons of **methyl isocyanate** leaked from a pesticide plant, killing thousands of people and injuring hundreds of thousands. Follow-up studies have shown that the incident caused increased mortality and continued effects on health, including airway disease, eye diseases, and pregnancy losses.

The company involved in the leak tried to distance itself from the accident and prevent those affected from learning the true nature of the accident. The legal case went on for years. Eventually, families of the dead received an average of about \$2,200. While the company ceased operation at its Bhopal plant after the disaster, it did not clean up the site completely. The plant continues to leak several toxic chemicals and heavy metals into local aquifers.

 Survivors of the deadly industrial incident in Bhopal, India in 1984, protesting over the mishandling of the disaster

Figure 1. Survivors of the Bhopal disaster of 1984 protest over the mishandling of the disaster

Bhopal disaster protestors. [Photo]. In Encyclopædia Britannica. Retrieved from <http://www.britannica.com/event/Bhopal-disaster/images-videos/Survivors-of-the-1984-deadly-industrial-accident-in-Bhopal-India/192038>

#### What We've Covered

This section made the following main points:

- Toxicity can result from adverse cellular, biochemical, or macromolecular changes.
- Some chemicals affect only specific target organs; others can damage any cell or tissue they contact.
- Chemicals can affect organisms by multiple mechanisms and at the molecular level, leading to modern approaches such as Adverse Outcome Pathways (AOPs) and Mechanism of Actions (MOAs).
- Several factors influence toxicity, including form and innate chemical activity, dosage, exposure route, species, life stage, gender, absorption ability, metabolism, distribution, excretion, health and nutritional status, the presence of other chemicals, and circadian rhythms.
- Systemic toxic effects, which can occur at multiple sites, include:
  - Acute toxicity, which occurs almost immediately (seconds/minutes) after a single dose or series of doses within 24 hours.
  - Subchronic toxicity, which results from repeated exposure for several weeks or months.
  - Chronic toxicity, which damages specific organ systems over the course of many months or years.
  - Carcinogenicity, or abnormal cell growth and differentiation that can lead to cancer.
  - Developmental toxicity, which adversely affects the developing embryo or fetus.
  - Genetic toxicity, caused by damage to DNA and altered genetic expressions.
- Organ specific toxic effects include:

- Blood/cardiovascular toxicity, affecting the blood, bone marrow, or heart.
- Dermal toxicity, impacting the skin.
- Epigenetic alterations, changing genetic programming.
- Optical toxicity, adversely affecting the eyes.
- Hepatotoxicity, impacting the liver, bile duct, or gall bladder.
- Immunotoxicity, affecting the immune system.
- Nephrotoxicity, affecting the kidneys.
- Neurotoxicity, impacting the central nervous system.
- Reproductive toxicity, damaging the reproductive system.
- Respiratory toxicity, affecting the respiratory system.

### Coming Up...

In the next section, we will look at effects that can occur when two or more chemicals interact.

---

This page titled [Section 3: Toxic Effects](#) is shared under a [CC BY-NC 4.0](#) license and was authored, remixed, and/or curated by [ToxMSDT Online component](#) via [source content](#) that was edited to the style and standards of the LibreTexts platform.

## 3.1: Types of Toxic Effects

### Types of Toxic Effects

Many factors play a potential role in toxicity. The dosage (or amount of exposure) is the most important factor. A well-known saying, "**the dose makes the poison**" speaks to this principle.

Toxicity can result from adverse cellular, biochemical, or macromolecular changes. Some examples are noted below.

Many chemicals distribute in the body and often affect only specific **target organs**. However, other chemicals can damage any cell or tissue that they contact. The target organs that are affected may vary depending on dosage and route of exposure. For example, the central nervous system may be the target organ for toxicity from a chemical after acute exposure whereas the liver may be affected after chronic exposures.



Figure 3.1.1. Central nervous system (left); Liver (right)

(Image Source: iStock Photos, ©)

Chemicals can cause many types of toxicity by a variety of mechanisms. Some act locally such as when direct exposure triggers skin or eye irritation, whereas other chemical cause systemic effects in the body in sites remote from where the actual exposure occurred. Toxicity can act directly affect subcellular components, such as cell receptors, or it can cause problems at the cellular level, such as with exposures to caustic or corrosive substances.

For example, chemicals might:

- Themselves be toxic or require metabolism (chemical change within the body) before they cause toxicity.
- Cause damage leading to fibrosis as the body attempts to repair the toxicity.
- Damage or disrupt an enzyme system or protein synthesis.
- Produce reactive chemicals in cells.
- Cause changes in hormone signaling or other effects.
- Produce DNA damage or epigenetic changes.

Some chemicals may also act indirectly by:

- Modifying an essential biochemical function.
- Interfering with nutrition.
- Altering a physiological mechanism.



Figure 3.1.2. Chemicals can have a wide range of toxic effects

(Image Source: iStock Photos, ©)

#### Did you know?

**Mercury** is a naturally occurring heavy metal. **Methylmercury**, the most common organic mercury compound, can be formed in water and soil by bacteria. It builds up in the tissues of fish. Exposure to high levels of mercury and mercury compounds can cause death or permanently damage the brain and kidneys.

In the late 1950s, people living around Japan's Minamata Bay developed symptoms of severe methylmercury poisoning, some of whom died. Children exposed *in utero* were born with disabilities. Investigations showed that heavily contaminated sludge from a factory had been released into the bay, contaminating fish and shellfish. People who ate the fish and shellfish became ill. The events led to a better understanding of industrial pollution and how heavy metals can accumulate in systems.

In January 2013 the **Minamata Convention on Mercury** global treaty was agreed to by an intergovernmental committee. It seeks to protect human health and the environment from the adverse effects of mercury.



Figure 3.1.3. Fish and shellfish became contaminated with mercury, causing severe methylmercury poisoning in people and animals who consumed them

(Image Source: iStock Photos, ©)



Because chemicals can affect organisms by different mechanisms and at the molecular level, there are new ways to conduct toxicity testing.

An emerging approach is to use **Adverse Outcome Pathways (AOPs)**, which evaluate changes in normal cellular pathways. AOPs reflect the move away from high-dose studies in laboratory animals for toxicity testing to *in vitro* methods that evaluate changes in normal cellular pathways using human-relevant cells or tissues.

Other terms that describe changes resulting from the exposure of a living organism to a substance include mode of action (MoA) and mechanism of action (MOA).

- **Mode of action (MoA)** (older term) — describes a functional or anatomical change at the *cellular* level.
- **Mechanism of action (MOA)** — describes such changes at the *molecular* level.

More information about toxicity testing can be found in the **Hazard Identification** section.

---

This page titled [3.1: Types of Toxic Effects](#) is shared under a [CC BY-NC 4.0](#) license and was authored, remixed, and/or curated by [ToxMSDT Online component](#) via [source content](#) that was edited to the style and standards of the LibreTexts platform.

## 3.2: Factors Affecting Toxicity

### Factors Influencing Toxicity

In some instances, individuals can have unpredictable reactions, or **idiosyncratic responses**, to a drug or other substance. An idiosyncratic response is uncommon, and it is sometimes impossible to understand whether it is the result of a genetic predisposition or has some other cause such as the status of the immune system. It could result in an abnormally small or short, or abnormally large or long response to the drug or other substance. Or, the response could be qualitatively different than what has been observed in most other individuals.

The toxicity of a substance usually depends on the following factors:

- Form and innate chemical activity
- Dosage, especially dose-time relationship
- Exposure route
- Species
- Life stage, such as infant, young adult, or elderly adult
- Gender
- Ability to be absorbed
- Metabolism
- Distribution within the body
- Excretion
- Health of the individual, including organ function and pregnancy, which involves physiological changes that could influence toxicity
- Nutritional status
- Presence of other chemicals
- Circadian rhythms (the time of day a drug or other substance is administered)

### Factors Related to the Substance

#### Form and Innate Chemical Activity

The **form** of a substance may have a profound impact on its toxicity especially for metallic elements, also termed heavy metals. For example, the toxicity of mercury vapor differs greatly from methyl mercury. Another example is chromium.  $\text{Cr}^{3+}$  is relatively nontoxic whereas  $\text{Cr}^{6+}$  causes skin or nasal corrosion and lung cancer.

The **innate chemical activity** of substances also varies greatly. Some can quickly damage cells causing immediate cell death. Others slowly interfere only with a cell's function. For example:

- Hydrogen cyanide binds to the enzyme cytochrome oxidase resulting in cellular hypoxia and rapid death.
- Nicotine binds to cholinergic receptors in the central nervous system (CNS) altering nerve conduction and inducing gradual onset of paralysis.

#### Dosage

The **dosage** is the most important and critical factor in determining if a substance will be an *acute* or a *chronic* toxicant. Virtually all chemicals can be acute toxicants if sufficiently large doses are administered. Often the toxic mechanisms and target organs are different for acute and chronic toxicity. Examples are:

Toxicant	Acute Toxicity	Chronic Toxic Effects
<b>Ethanol</b>	CNS depression	Liver cirrhosis
<b>Arsenic</b>	Gastrointestinal damage	Skin/liver cancer

Table 3.2.1. Examples of acute and chronic toxicity

## Exposure Route

The way an individual comes in contact with a toxic substance, or **exposure route**, is important in determining toxicity. Some chemicals may be highly toxic by one route but not by others. Two major reasons are differences in absorption and distribution within the body. For example:

- Ingested chemicals, when absorbed from the intestine, distribute first to the liver and may be immediately detoxified.
- Inhaled toxicants immediately enter the general blood circulation and can distribute throughout the body prior to being detoxified by the liver.

Different target organs often are affected by different routes of exposure.



Figure 3.2.1. Ingestion

(Image Source: ORAU, ©)



Figure 3.2.2. Inhalation

(Image Source: ORAU, ©)

## Absorption

The **ability to be absorbed** is essential to systemic toxicity. Some chemicals are readily absorbed and others are poorly absorbed. For example, nearly all alcohols are readily absorbed when ingested, whereas there is virtually no absorption for most polymers. The rates and extent of absorption may vary greatly depending on the form of a chemical and the route of exposure to it. For example:

- Ethanol is readily absorbed from the gastrointestinal tract but poorly absorbed through the skin.
- Organic mercury is readily absorbed from the gastrointestinal tract; inorganic lead sulfate is not.

## Factors Related to the Organism

### Species

Toxic responses can vary substantially depending on the species. Most differences between species are attributable to differences in metabolism. Others may be due to anatomical or physiological differences. For example, rats cannot vomit and expel toxicants before they are absorbed or cause severe irritation, whereas humans and dogs are capable of vomiting.

**Selective toxicity** refers to species differences in toxicity between two species simultaneously exposed. This is the basis for the effectiveness of pesticides and drugs. For example:

- An insecticide is lethal to insects but relatively nontoxic to animals.
- Antibiotics are selectively toxic to microorganisms while virtually nontoxic to humans.

### Life Stage

An individual's age or **life stage** may be important in determining his or her response to toxicants. Some chemicals are more toxic to infants or the elderly than to young adults. For example:

- Parathion is more toxic to young animals.
- Nitrosamines are more carcinogenic to newborn or young animals.



Figure 3.2.3. An individual's life stage can impact that person's response to toxicants

(Image Source: iStock Photos, ©)

### Gender

Gender can play a big role in influencing toxicity. Physiologic differences between men and women, including differences in pharmacokinetics and pharmacodynamics, can affect drug activity.

In comparison with men, pharmacokinetics in women generally can be impacted by their lower body weight, slower gastrointestinal motility, reduced intestinal enzymatic activity, and slower kidney function (glomerular filtration rate). Delayed

gastric emptying in women may result in a need for them to extend the interval between eating and taking medications that require absorption on an empty stomach. Other physiologic differences between men and women also exist. Slower renal clearance in women, for example, may result in a need for dosage adjustment for drugs such as digoxin that are excreted via the kidneys.

In general, pharmacodynamic differences between women and men include greater sensitivity to and enhanced effectiveness, in women, of some drugs, such as beta blockers, opioids, and some antipsychotics.

Studies in animals also have identified gender-related differences. For example:

- Male rats are 10 times more sensitive than females to liver damage from DDT.
- Female rats are twice as sensitive to parathion as are male rats.



Figure 3.2.4 *Gender symbols for female (left) and male (right)*  
(Image Source: iStock Photos, ©)

## Metabolism

**Metabolism**, also known as biotransformation, is the conversion of a chemical from one form to another by a biological organism. Metabolism is a major factor in determining toxicity. The products of metabolism are known as metabolites. There are two types of metabolism:

1. Detoxification
2. Bioactivation

In **detoxification**, a xenobiotic is converted to a less toxic form. This is a natural defense mechanism of the organism. Generally, detoxification converts lipid-soluble compounds to polar compounds.

In **bioactivation**, a xenobiotic may be converted to more reactive or toxic forms. Cytochrome P-450 (CYP450) is an example of an enzyme pathway used to metabolize drugs. In the elderly, CYP450 metabolism of drugs such as phenytoin and carbamazepine may be decreased. Therefore, the effect of those drugs may be less pronounced. CYP450 metabolism also can be inhibited by many drugs. Risk of toxicity may be increased if a CYP450 enzyme-inhibiting drug is given with one that depends on that pathway for metabolism.

There is awareness that the gut microbiota can impact the toxicity of drugs and other chemicals. For example, gut microbes can metabolize some environmental chemicals and bacteria-dependent metabolism of some chemicals can modulate their toxicity. Also, environmental chemicals can alter the composition and/or the metabolic activity of the gastrointestinal bacteria, thus contributing in a meaningful way to shape an individual's microbiome. The study of the consequences of these changes is an emerging area of toxicology.

[Learn more](#) about human exposure to pollutants and their interaction with the GI microbiota.

[Learn more](#) about the microbiome and toxicology.

## Distribution Within the Body

The **distribution** of toxicants and toxic metabolites throughout the body ultimately determines the sites where toxicity occurs. A major determinant of whether a toxicant will damage cells is its lipid solubility. If a toxicant is lipid-soluble, it readily penetrates cell membranes. Many toxicants are stored in the body. Fat tissue, liver, kidney, and bone are the most common storage sites. Blood serves as the main avenue for distribution. Lymph also distributes some materials.

## Excretion

The site and rate of **excretion** is another major factor affecting the toxicity of a xenobiotic. The kidney is the primary excretory organ, followed by the gastrointestinal tract, and the lungs (for gases). Xenobiotics may also be excreted in sweat, tears, and milk.

A large volume of blood serum is filtered through the kidney. Lipid-soluble toxicants are reabsorbed and concentrated in kidney cells. Impaired kidney function causes slower elimination of toxicants and increases their toxic potential.

## Health Status

The health of an individual or organism can play a major role in determining the levels and types of potential toxicity. For example, an individual may have pre-existing kidney or liver disease. Certain conditions, such as pregnancy, also are associated with

physiological changes in kidney function that could influence toxicity.

### Nutritional Status

Diet (nutritional status) can be a major factor in determining who does or does not develop toxicity. For example:

- Consumption of fish that have absorbed mercury from contaminated water can result in mercury toxicity; an antagonist for mercury toxicity is the nutrient selenium.
- Some vegetables can accumulate cadmium from contaminated soil; an antagonist for cadmium toxicity is the nutrient zinc.
- Grapefruit contains a substance that inhibits the P450 drug detoxification pathway, making some drugs more toxic.

Find out more about nutrition and chemical toxicity [here](#).

### Circadian Rhythms

Circadian rhythms can play a role in toxicity. For example, rats administered an immunosuppressive drug had severe toxicity in their intestines 7 hours after light onset compared to controls and to other times in the day. The rats had changes in their digestive enzyme activity and other physiological indicators at this dosing time.

Find out more about circadian rhythm and gut toxicity [here](#).

### Other Factors

#### Presence of Other Chemicals

The presence of other chemicals, at the same time, earlier, or later may:

- **Decrease toxicity** (antagonism)
- **Add to toxicity** (additivity)
- **Increase toxicity** (synergism or potentiation)

For example:

- Antidotes used to counteract the effects of poisons function through antagonism (atropine counteracts poisoning by organophosphate insecticides).
- Alcohol may enhance the effect of many antihistamines and sedatives.
- A synergistic interaction between the antioxidant butylated hydroxytoluene (BHT) and a certain concentration of oxygen results in lung damage in the form of interstitial pulmonary fibrosis.

Information on additional examples of lung damage from chemical interactions can be found [here](#).

#### Knowledge Check

1. A target organ is an organ that:

- Absorbs a toxic substance
- Stores an absorbed substance or its metabolite
- Is damaged by a toxic substance

#### Answer

Is damaged by a toxic substance

A target organ is an organ in which a substance exerts a toxic effect.

2. What are the important factors that influence the degree of toxicity of a substance?

- Innate chemical activity, form, dosage, and exposure route
- The species, life stage, gender, health status, nutritional status, and circadian rhythms of the organism
- Absorption, metabolism, distribution within the body, excretion, and presence of other chemicals
- All of the above

**Answer**

All of the above

3. Metabolism, or biotransformation, of a xenobiotic:

- Always results in reduced toxicity of the xenobiotic
- May result in detoxification or bioactivation
- Has no influence on the toxicity of the xenobiotic

**Answer**

May result in detoxification or bioactivation

Metabolism of a xenobiotic results in either detoxification, which converts the xenobiotic to a less toxic form, or bioactivation, which converts the xenobiotic to more reactive or toxic forms. For example, a xenobiotic itself might not be carcinogenic, but a metabolite of the xenobiotic might be.

4. An antibiotic administered to humans kills bacteria in the body but does not harm human tissues. This is an example of:

- Selective toxicity
- Acute toxicity
- Varying absorption of the antibiotic

**Answer**

Selective Toxicity

Selective toxicity refers to differences in toxicity between two species simultaneously exposed, much like the antibiotic in this example.

5. A major determinant of whether a toxicant will damage cells is its:

- Acidity
- Biotransformation
- Lipid solubility

**Answer**

Lipid solubility

A major determinant of whether or not a toxicant will damage cells is its lipid solubility. If a toxicant is lipid-soluble, it readily penetrates cell membranes.

This page titled [3.2: Factors Affecting Toxicity](#) is shared under a [CC BY-NC 4.0](#) license and was authored, remixed, and/or curated by [ToxMSDT Online component](#) via [source content](#) that was edited to the style and standards of the LibreTexts platform.

## 3.3: Systemic Toxic Effects

### Types of Systemic Toxic Effects

Toxic effects are generally categorized according to the site of the toxic effect. In some cases, the effect may occur at only one site. This site is termed the **specific target organ**.

In other cases, toxic effects may occur at multiple sites. This is known as **systemic toxicity**. Types of systemic toxicity include:

- Acute Toxicity
- Subchronic Toxicity
- Chronic Toxicity
- Carcinogenicity
- Developmental Toxicity
- Genetic Toxicity (somatic cells)

### Acute Toxicity

**Acute toxicity** occurs almost immediately (seconds/minutes/hours/days) after an exposure. An **acute exposure** is usually a single dose or a series of doses received within a 24-hour period. Death can be a major concern in cases of acute exposures. For example:

- In 1989, 5,000 people died and 30,000 were permanently disabled due to exposure to methyl isocyanate from an industrial accident in India.
- Many people die each year from inhaling carbon monoxide from faulty heaters.



Figure 3.3.1. Faulty gas heaters can emit toxic carbon monoxide  
(Image Source: iStock Photos, ©)

### Subchronic Toxicity

**Subchronic toxicity** results from repeated exposure for several weeks or months. This is a common human exposure pattern for some pharmaceuticals and environmental agents. For example:

- Ingestion of warfarin (Coumadin®) tablets (blood thinners) for several weeks as a treatment for venous thrombosis can cause internal bleeding.
- Workplace exposure to lead over a period of several weeks can result in anemia.



Figure 3.3.2. Warfarin Tablets (left); old lead pipes (right)  
(Image Source: iStock Photos, ©)

### Chronic Toxicity

**Chronic toxicity** represents cumulative damage to specific organ systems and takes many months or years to become a recognizable clinical disease. Damage due to subclinical individual exposures may go unnoticed. With repeated exposures or long-term continual exposure, the damage from this type of exposure slowly builds up (cumulative damage) until the damage exceeds the threshold for chronic toxicity. Ultimately, the damage becomes so severe that the organ can no longer function normally and a variety of chronic toxic effects may result.

Chronic toxic effects include:

- Cirrhosis in alcoholics who have ingested ethanol for several years.
- Chronic kidney disease in workmen with several years of exposure to lead.
- Chronic bronchitis in long-term cigarette smokers.
- Pulmonary fibrosis in coal miners (black lung disease).



Figure 3.3.3. Smoking cigarettes and/or drinking alcohol over a long period of time can lead to chronic toxicity  
(Image Source: iStock Photos, ©)

## Carcinogenicity

**Carcinogenicity** is a **complex multistage process** of abnormal cell growth and differentiation that can lead to cancer. The two stages of carcinogenicity are:

1. **Initiation** — a normal cell undergoes irreversible changes.
2. **Promotion** — initiated cells are stimulated to progress to cancer.

Chemicals can act as **initiators** or **promoters**.

The initial transformation that causes normal cells to undergo irreversible changes results from the mutation of the cellular genes that control normal cell functions. The mutation may lead to abnormal cell growth. It may involve a loss of suppresser genes that usually restrict abnormal cell growth. Many other factors are involved, such as growth factors, immune suppression, and hormones.

A **tumor (neoplasm)** is simply an uncontrolled growth of cells:

- **Benign tumors** grow at the site of origin; do not invade adjacent tissues or metastasize; and generally are treatable.
- **Malignant tumors (cancer)** invade adjacent tissues or migrate to distant sites (**metastasis**). They are more difficult to treat and often cause death.

## Developmental Toxicity

**Developmental toxicity** pertains to adverse toxic effects to the developing embryo or fetus. It can result from toxicant exposure to either parent before conception or to the mother and her developing embryo or fetus. The three basic types of developmental toxicity are:

1. **Embryolethality** — failure to conceive, spontaneous abortion, or stillbirth.
2. **Embryotoxicity** — growth retardation or delayed growth of specific organ systems.
3. **Teratogenicity** — irreversible conditions that leave permanent birth defects in live offspring, such as cleft palette or missing limbs.

Chemicals cause developmental toxicity in two ways:

1. They act directly on cells of the embryo, causing cell death or cell damage, leading to abnormal organ development.
2. They induce a mutation in a parent's germ cell, which is transmitted to the fertilized ovum. Some mutated fertilized ova develop into abnormal embryos.



Figure 3.3.4. Ultrasound images of a developing fetus  
(Image Source: iStock Photos, ©)

## Genetic Toxicity

**Genetic toxicity** results from damage to DNA and altered genetic expression. This process is known as **mutagenesis**. The genetic change is referred to as a **mutation** and the agent causing the change is called a **mutagen**. There are three types of genetic changes:

1. **Gene mutation** — change in DNA sequence within a gene.
2. **Chromosome aberration** — changes in the chromosome structure.
3. **Aneuploidy** or **polyploidy** — increase or decrease in number of chromosomes.

If the mutation occurs in a germ cell, the effect is **heritable**. This means there is no effect on the exposed person; rather, the effect is passed on to future generations.

If the mutation occurs in a **somatic** cell, it can cause altered cell growth (for example, cancer) or cell death (for example, teratogenesis) in the exposed person.



Figure 3.3.5. Genetic toxicity results from damage to DNA and altered genetic expression  
(Image Source: iStock Photos, ©)



This page titled [3.3: Systemic Toxic Effects](#) is shared under a [CC BY-NC 4.0](#) license and was authored, remixed, and/or curated by [ToxMSDT Online component](#) via [source content](#) that was edited to the style and standards of the LibreTexts platform.

## 3.4: Organ Specific Toxic Effects

### Organ Specific Toxic Effects

Toxic effects that pertain to specific organs and organ systems include:

 Illustration of a male and female human body. The following organs are also illustrated: a heart representing blood/cardiovascular toxicity, a hand representing dermal toxicity, a chromosome representing epigenetic alterations and genetic toxicity, an eye representing eye toxicity, a liver representing hepatotoxicity, a bone and spleen representing immunotoxicity, kidneys representing nephrotoxicity, a brain representing neurotoxicity, female reproductive organs and sperm representing reproductive toxicity, and lungs representing respiratory toxicity.

Figure 3.4.1. Organ-specific toxic effects pertain to specific organs and organ systems (Image Source: Adapted from iStock Photos, ©)

### Blood and Cardiovascular/Cardiac Toxicity

**Blood and Cardiovascular/Cardiac Toxicity** results from xenobiotics acting directly on cells in circulating blood, bone marrow, and the heart. Examples of blood and cardiovascular/cardiac toxicity are:

- Hypoxia due to carbon monoxide binding of hemoglobin preventing transport of oxygen.
- Decrease in circulating leukocytes due to chloramphenicol damage to bone marrow cells.
- Leukemia due to benzene damage of bone marrow cells.
- Arteriosclerosis due to cholesterol accumulation in arteries and veins.
- Death of normal cells in and around the heart as a result of exposure to **drugs used to treat cancer**.

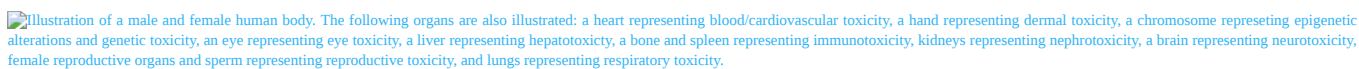
 Illustration of the human heart

Figure 3.4.2. Heart cells can be damaged by exposure to certain drugs (Image Source: iStock Photos, ©)

### Dermal Toxicity

**Dermal Toxicity** can occur when a toxicant comes into direct contact with the skin or is distributed to it internally. Effects range from mild irritation to severe changes, such as irreversible damage, hypersensitivity, and skin cancer. Examples of dermal toxicity include:

- Dermal irritation from skin exposure to gasoline.
- Dermal corrosion from skin exposure to sodium hydroxide (lye).
- Dermal itching, irritation, and sometimes painful **rash** from poison ivy, caused by **urushiol**.
- Skin cancer due to ingestion of arsenic or skin exposure to UV light.

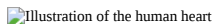
 Illustration of the human hand

Figure 3.4.3. Hand (Image Source: iStock Photos, ©)

### Epigenetic Alterations

Epigenetics is an emerging area in toxicology. In the field of genetics, epigenetics involves studying how external or environmental factors can switch genes on and off and change the programming of cells.

More specifically, epigenetics refers to stable changes in the programming of gene expression which can alter the phenotype without changing the DNA sequence (genotype). Epigenetic modifications include DNA methylation, covalent modifications of histone tails, and regulation by non-coding RNAs, among others.

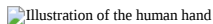
Toxicants are examples of factors that can alter genetic programming.

 Illustration of a human chromosome

Figure 3.4.4. Chromosome, which contains DNA (Image Source: iStock Photos, ©)

In the past, toxicology studies have assessed toxicity without measuring its impact at the level where gene expression occurs. Exogenous agents could cause long-term toxicity that continues after the initial exposure has disappeared, and such toxicities remain undetected by current screening methods. Thus, a current challenge in toxicology is to **develop screening methods that would detect epigenetic alterations** caused by toxicants.

Research is being done to assess epigenetic changes caused by toxicants. For example, the **National Institutes of Health (NIH) National Institute of Environmental Health Sciences (NIEHS) Environmental Epigenetics program** provides funding for a variety of research projects that use state-of-the-art technologies to analyze epigenetic changes caused by environmental exposures. NIEHS-supported researchers use animals, cell cultures, and human tissue samples to pinpoint how epigenetic changes can lead to harmful health effects and can potentially be passed down to the next generation.

## Eye Toxicity

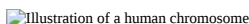
**Eye Toxicity** results from direct contact with or internal distribution to the eye. Because the cornea and conjunctiva are directly exposed to toxicants, conjunctivitis and corneal erosion may be observed following occupational exposure to chemicals. Many household items can cause conjunctivitis. Chemicals in the circulatory system can distribute to the eye and cause corneal opacity, cataracts, and retinal and optic nerve damage. For example:

- Acids and strong alkalis may cause severe corneal corrosion.
- Corticosteroids may cause cataracts.
- Methanol (wood alcohol) may damage the optic nerve.

 Illustration of a human eye

Figure 3.4.5. Eye (Image Source: iStock Photos, ©)

## Hepatotoxicity

**Hepatotoxicity** is toxicity to the liver, bile duct, and gall bladder. Because of its extensive blood supply and significant role in metabolism, the liver is particularly susceptible to xenobiotics. Thus, it is exposed to high doses of the toxicant or its toxic metabolites. The primary forms of hepatotoxicity are:

- **Steatosis** — lipid accumulation in the hepatocytes.
- **Chemical hepatitis** — inflammation of the liver.
- **Hepatic necrosis** — death of the hepatocytes.
- **Intrahepatic cholestasis** — backup of bile salts into the liver cells.
- **Hepatic cancer** — cancer of the liver.
- **Cirrhosis** — chronic fibrosis, often due to alcohol.
- **Hypersensitivity** — immune reaction resulting in hepatic necrosis.

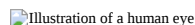
 Illustration of a human liver

Figure 3.4.6. Liver (Image Source: iStock Photos, ©)

**Related Resource: LiverTox**<sup>®</sup>

## Immunotoxicity

**Immunotoxicity** is toxicity of the immune system. It can take several forms:

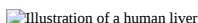
- Hypersensitivity (allergy and autoimmunity)
- Immunodeficiency
- Uncontrolled proliferation (leukemia and lymphoma)

The normal function of the immune system is to recognize and defend against foreign invaders. This is accomplished by production of cells that engulf and destroy the invaders or by antibodies that inactivate foreign material. Examples include:

- Contact dermatitis due to exposure to poison ivy.
- Systemic lupus erythematosus ("lupus") in workers exposed to hydrazine.
- Immunosuppression by cocaine.
- Leukemia induced by benzene.

 Illustration of a human chromosome

Figure 3.4.7. Bone (which contains bone marrow) and spleen, both components of the immune system, which recognizes and defends against foreign invaders (Image Source: iStock Photos, ©)

## Nephrotoxicity

The kidney is highly susceptible to toxicants because a high volume of blood flows through the organ and it filters large amounts of toxins which can concentrate in the kidney tubules.

**Nephrotoxicity** is toxicity to the kidneys. It can result in systemic toxicity causing:

- Decreased ability to excrete body wastes.
- Inability to maintain body fluid and electrolyte balance.

- Decreased synthesis of essential hormones (for example, erythropoietin, which increases the rate of blood cell production).

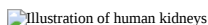

Figure 3.4.8. Kidneys (Image Source: iStock Photos, ©)

## Neurotoxicity

**Neurotoxicity** represents toxicant damage to cells of the central nervous system (brain and spinal cord) and the peripheral nervous system (nerves outside the CNS). The primary types of neurotoxicity are:

- Neuronopathies (neuron injury)
- Axonopathies (axon injury)
- Demyelination (loss of axon insulation)
- Interference with neurotransmission

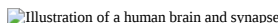

Figure 3.4.9. Brain and synapse are susceptible to toxicant damage (Image Source: iStock Photos, ©)

## Reproductive Toxicity

**Reproductive Toxicity** involves toxicant damage to either the male or female reproductive system. Toxic effects may cause:

- Decreased libido and impotence.
- Infertility.
- Interrupted pregnancy (abortion, fetal death, or premature delivery).
- Infant death or childhood morbidity.
- Altered sex ratio and multiple births.
- Chromosome abnormalities and birth defects.
- Childhood cancer.

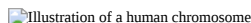

Figure 3.4.10. Female reproductive organs (left); male and female germ cells (right) (Image Source: iStock Photos, ©)

## Respiratory Toxicity

**Respiratory Toxicity** relates to effects on the upper respiratory system (nose, pharynx, larynx, and trachea) and the lower respiratory system (bronchi, bronchioles, and lung alveoli). The primary types of respiratory toxicity are:

- Pulmonary irritation
- Asthma/bronchitis
- Reactive airway disease
- Emphysema
- Allergic alveolitis
- Fibrotic lung disease
- Pneumoconiosis
- Lung cancer

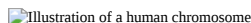

Figure 3.4.11. Lungs (Image Source: iStock Photos, ©)

## Knowledge Check

### Knowledge Check

1. Toxic effects are primarily categorized into two general types:

- Systemic or organ-specific effects
- Carcinogenic or teratogenic effects
- Hepatic or nephrotoxic effects

**Answer**

Systemic or organ-specific effects - **This is the correct answer.**

Toxic effects are broadly categorized as either systemic or organ-specific effects.

2. What is the main difference between acute and chronic toxicity?

- Different organs are involved
- Acute toxicity occurs only after a single dose, whereas chronic toxicity occurs with multiple doses
- Acute toxicity appears within hours or days of an exposure, whereas chronic toxicity takes many months or years to become a recognizable clinical disease
- Acute toxicity is less likely to lead to death than is chronic toxicity

**Answer**

Acute toxicity appears within hours or days of an exposure, whereas chronic toxicity takes many months or years to become a recognizable clinical disease - **This is the correct answer.**

3. Police respond to a 911 call in which two people are found dead in an enclosed bedroom heated by an unvented kerosene stove. There was no sign of trauma or violence. A likely cause of death is:

- Excess oxygen generated by the combustion of kerosene
- Acute toxicity due to uncombusted kerosene fumes
- Acute toxicity due to carbon monoxide poisoning

**Answer**

Acute toxicity due to carbon monoxide poisoning - **This is the correct answer.**

The victims most likely died as a result of acute toxicity from exposure to carbon monoxide.

4. Genetic toxicity can result in:

- Gene mutation
- Changes in the structure and/or number of chromosomes
- Epigenetic alterations
- All of the above

**Answer**

All of the above - **This is the correct answer.**

Genetic toxicity can cause gene mutations, changes in chromosome structure (aberration), increases or decreases in the number of chromosomes (aneuploidy or polyploidy), and changes to genetic programming (epigenetic alterations).

This page titled [3.4: Organ Specific Toxic Effects](#) is shared under a [CC BY-NC 4.0](#) license and was authored, remixed, and/or curated by [ToxMSDT Online component](#) via [source content](#) that was edited to the style and standards of the LibreTexts platform.

## CHAPTER OVERVIEW

### Section 4: Interactions

#### Learning Objectives

After completing this lesson, you will be able to:

- Explain the impacts that can be experienced when two or more chemicals interact.
- List realistic examples of chemical interactions.

#### In this section...

Topics include:

##### [4.1: Interactions](#)

#### Did you know?

Gasoline is a volatile, complex mixture of hydrocarbon compounds. The mixture is easily vaporized during handling in normal conditions. People are exposed to this complex substance during refueling at service stations. [More information](#) is available on consumer exposure to gasoline.

In this section, we will look into the effects of interactions among such chemicals.

Closeup photo of a gasoline nozzle inserted into the fuel tank of a car

Figure 1. Refueling car

(Image Source: iStock Photos, ©)

#### What We've Covered

In this section, we explored the following key points:

- Interactions between multiple chemicals can:
  - Decrease toxicity (antagonism).
  - Add to toxicity (additivity).
  - Increase toxicity (synergism or potentiation).
- Interactions can occur by simultaneous exposure or if exposure to the agents is separated by time.
- People are normally exposed to many chemicals and combinations of chemicals every day.
- Emerging approaches in assessing interactions include:
  - Adverse outcome pathways (AOPs).
  - *In vitro* methods.
  - "Omics" techniques.
  - *In silico* approaches.

#### Coming Up...

In the next section, we will explore various methods for testing toxicity.

---

This page titled [Section 4: Interactions](#) is shared under a [CC BY-NC 4.0](#) license and was authored, remixed, and/or curated by [ToxMSDT Online component](#) via [source content](#) that was edited to the style and standards of the LibreTexts platform.

## 4.1: Interactions

### Interactions

As noted in "**Factors Influencing Toxicity**," the presence of other chemicals, at the same time, earlier, or later may:

- Decrease toxicity (**antagonism**).
- Add to toxicity (**additivity**).
- Increase toxicity (**synergism** or **potentiation**) of some chemicals.

For example, interactions between two or more toxic agents can produce lung damage by interactions:

- Between chemicals.
- Between chemicals and receptors.
- In which a first agent modifies the cell and tissue response to a second agent.

Interactions may occur by:

- Simultaneous exposure to two or more agents.
- Exposure to two or more agents at different times.

 Lab worker pouring a red chemical into a yellow chemical

Figure 4.1.1. Interactions between two or more substances often impact toxicity  
(Image Source: iStock Photos, ©)

### Sources of Interactions

Humans are normally exposed to many chemicals at one time. For example, the use of consumer products, medical treatments, and exposures from the diet and environment (such as from soil, air, and water) can consist of exposures to hundreds, if not thousands, of chemicals. Other examples include:

- Hospital patients receive an average of six drugs daily.
- Consumers may use five or more consumer products before breakfast (for example, soap, shampoo, conditioner, toothpaste, and deodorant).
- Home influenza treatment consists of aspirin, antihistamines, and cough syrup taken simultaneously.
- Drinking water may contain small amounts of pesticides, heavy metals, solvents, and other organic chemicals.
- Air often contains mixtures of hundreds of chemicals such as automobile exhaust and cigarette smoke.
- Gasoline vapor at service stations is a mixture of 40-50 chemicals.

 Photo of various personal care products, unlabeled; including hand soap, mouthwash, shampoo, body wash, toothpaste, cotton swabs, cotton balls, and a towel

Figure 4.1.2. The use of personal care products can result in exposures to hundreds of chemicals  
(Image Source: iStock Photos, ©)

 Photo of cold and flu over the counter remedies; includes a cap full of cough syrup, cough drops, and a spilled bottle of pills

Figure 4.1.3. *Cold and flu remedies are another source of chemical exposure*  
(Image Source: iStock Photos, ©)

Toxicology studies and human health risk assessments have traditionally focused primarily on a single chemical. However, as noted above, people are exposed to many chemicals every day. They are also exposed to non-chemical stressors every day and throughout a lifetime.

In addition, non-chemical stressors include infectious agents, diet, and psychosocial stress, all of which have potential roles in contributing to the health effects associated with chemical exposures.

### Approaches for Assessing Interactions

Development of methods to assess the health effects associated with complex exposures is underway at **various organizations**.

Non-animal tools and approaches are demonstrating high potential for use in assessing combined effects of chemicals on humans and the environment. These tools and approaches may help uncover information about new mixture components or entire mixtures,

which can promote understanding of the underlying mechanisms of their combined effects. The strategies for assessing interactions rely less on *in vivo* testing and more on non-animal studies and computational tools and incorporate emerging approaches such as:

- The adverse outcome pathway (AOP) concept.
- *In vitro* methods.
- “Omics” techniques.
- *In silico* approaches such as quantitative structure activity relationships (QSARs).
- Read-across.
- Toxicokinetic modeling.
- Integrated approaches to testing and assessment (IATA).

The goals include the ability to development more effective and comprehensive regulatory assessments while reducing the reliance on animal testing.



Figure 4.1.4 *Modern testing methods rely heavily on computational toxicology*  
(Image Source: iStock Photos, ©)

#### Knowledge Check

The presence of one chemical decreasing toxicity of another chemical is called:

- Additivity
- Antagonism
- Synergism

#### Answer

Antagonism - **This is the correct answer.**

When the presence of another chemical decreases toxicity of a chemical, this is called antagonism.

Additivity is when the combined toxic effect of two chemicals when given together is less than the sum of their individually measured toxic effects.

- True
- False

#### Answer

False - **This is the correct answer.**

An additive effect occurs when the combined effects of two or more chemicals is equal to the sum of the effects of each chemical given alone.

Piperonyl butoxide is not an insecticide; however, it can greatly increase the effects of a pyrethrum insecticide. Thus, piperonyl butoxide can be called a synergist and this interaction can be called synergism.

- True
- False

#### Answer

True - **This is the correct answer.**

The interaction of this combination is synergism. Synergists are used to enhance the toxicity of several commonly used insecticides.

This page titled [4.1: Interactions](#) is shared under a [CC BY-NC 4.0](#) license and was authored, remixed, and/or curated by [ToxMSDT Online component](#) via [source content](#) that was edited to the style and standards of the LibreTexts platform.



## CHAPTER OVERVIEW

### Section 5: Toxicity Testing Methods

#### Learning Objectives

After completing this lesson, you will be able to:

- Explain modern approaches to testing for and assessing toxicity.
- Identify sources of information related to alternatives to using animals to assess toxicity.
- Explain how clinical investigations and epidemiology studies are used to evaluate toxicity to humans.

#### In this section...

Topics include:

[5.1: Testing and Assessing Toxicity](#)

[5.2: Clinical Investigations and Other Types of Human Data](#)

[5.3: Epidemiology Studies](#)

#### What We've Covered

This section included the following key points:

- The 3Rs concept of using test methods replace the use of animals with other types of studies and approaches, reduce the number of animals used in studies, and refine study procedures to cause less pain or stress to animals.
- ALTBIB is a comprehensive starting point provided by NLM to find information related to alternatives to animal testing.
- Animal tests for toxicity have been conducted prior to and in parallel with human clinical investigations.
- Standardized animal tests have been developed for testing:
  - Acute toxicity
  - Subchronic toxicity
  - Chronic toxicity
  - Carcinogenicity
  - Reproductive toxicity
  - Developmental toxicity
  - Dermal toxicity
  - Ocular toxicity
  - Neurotoxicity
  - Genetic toxicity
- Modern approaches to toxicity testing are preferred over animal testing and include:
  - *In vitro* methods, which are performed outside living organisms.
  - *In silico* methods, which are performed using computers and computer simulation.
  - Chip models, which include human cell cultures placed on computer chips for study.
- Approaches used for testing pharmaceuticals include:
  - Clinical investigations, in which human subjects are studied with clinical observations and laboratory measurements.
  - Epidemiological studies, involving observation of humans exposed to xenobiotics in their regular life or occupation.
  - Reports of adverse reactions to drugs.
- Consumer products and the chemicals they contain are tested through:
  - *In silico* data from computer models.
  - *In vitro* data from tests performed as alternatives to animal testing.
  - Animal study data.
  - Human data from premarketing and postmarketing studies.

## Coming Up...

In the next section, we will explore the concept of risk assessment.

---

This page titled [Section 5: Toxicity Testing Methods](#) is shared under a [CC BY-NC 4.0](#) license and was authored, remixed, and/or curated by [ToxMSDT Online component](#) via [source content](#) that was edited to the style and standards of the LibreTexts platform.

## 5.1: Testing and Assessing Toxicity

### Testing and Assessing Toxicity

Alternatives to animal testing have emerged in recent years.

Since about 1990, numerous attempts have been made around the world to reduce the use of and replace laboratory animals in toxicology and other studies. These efforts have involved finding alternatives to animal testing and incorporating the "3Rs" concept (Replace, Reduce and Refine), which means using test methods that:

- **Replace** the use of animals with other types of studies and approaches.
- **Reduce** the number of animals in studies.
- **Refine** the procedures to make studies less painful or stressful to the animals.

Regulatory authorities, companies, and others have endorsed the principle of the 3Rs, and alternative testing methods have been and are being developed. An international group that has played a key role is the International Cooperation on Alternative Test Methods (ICATM). Established in 2009, ICATM includes representatives of **organizations from various countries**.

### Finding Information about Alternatives to Animal Testing

Many countries including the United States, Canada, and the European Union member states, require that a comprehensive search for possible alternatives be completed before some or all research involving animals is begun. Because numerous Web resources are now available to provide guidance and other information on *in vitro* and other alternatives to animal testing, completing such searches and keeping current with information associated with alternatives to animal testing is much easier than it used to be.

#### ALTBIB, from NLM

The NLM ALTBI B ("Resources for Alternatives to the Use of Live Vertebrates in Biomedical Research and Testing") portal is a comprehensive starting point for finding information related to alternatives to animal testing. ALTBI B is available at <http://toxnet.nlm.nih.gov/altbib.html>.

It provides access to **PubMed**<sup>®</sup>/**MEDLINE**<sup>®</sup> citations relevant to alternatives to use of live vertebrates in biomedical research and testing.

**ALTBIB's topics** and subtopics are aligned with current approaches. For example, information is provided on *in silico*, *in vitro*, and improved (refined) animal testing methods and on testing strategies that incorporate these methods and other approaches.



Figure 5.1.1. NLM ALTBI B homepage

ALTBIB also provides access to news and additional resources, including information on the status of the evaluation and acceptance of alternative methods. Main categories include:

- Animal Alternatives News
- Additional Resources
- Evaluation/Acceptance of Test Methods

**Links to Specific Resources** (Sources Providing Animal Alternatives News, Key Organizations Providing Resources, and the Regulatory Acceptance of Specific Alternative Methods and Milestones in Non-animal Toxicity Testing)

### Animal Tests

**NOTE:** This information is provided for historical and other reasons, especially since animal testing is still being done in some cases, and because toxicologists, risk assessors, and others are faced with interpreting the results of new and old studies that used animals.

Animal tests for toxicity have been conducted prior to and in parallel with human clinical investigations as part of the non-clinical laboratory tests of pharmaceuticals. For pesticides and industrial chemicals, human testing is rarely conducted. Years ago, results from animal tests were often the only way to effectively predict toxicity in humans.

Animal tests were developed and used because:

- Chemical exposure can be precisely controlled.

- Environmental conditions can be well-controlled.
- Virtually any type of toxic effect can be evaluated.
- The mechanism by which toxicity occurs can be studied.



Figure 5.1.2 *Rats have traditionally been used in toxicity studies using animals*  
(Image Source: iStock Photos, ©)

### Standardized Animal Toxicity Tests

Animal methods to evaluate toxicity have been developed for a wide variety of toxic effects. Some procedures for routine safety testing have been standardized. **Standardized animal toxicity** tests have been highly effective in detecting toxicity that may occur in humans. As noted above, concern for animal welfare has resulted in tests that use humane procedures and only as many animals as are needed for statistical reliability.

To be standardized, a test procedure must have scientific acceptance as the most meaningful assay for the toxic effect. Toxicity testing can be very **specific** for a particular effect, such as dermal irritation, or it may be **general**, such as testing for unknown chronic effects.

**Standardized tests** have been developed for the following effects:

- Acute Toxicity
- Subchronic Toxicity
- Chronic Toxicity
- Carcinogenicity
- Reproductive Toxicity
- Developmental Toxicity
- Dermal Toxicity
- Ocular Toxicity
- Neurotoxicity
- Genetic Toxicity

### Species Selection

**Species selection** varies with the toxicity test to be performed. There is no single species of animal that can be used for all toxicity tests. Different species may be needed to assess different types of toxicity. The published literature (such as via PubMed) and online databases (such as TOXNET) should be searched for information from non-animal and animal studies, as well as for possible best approaches, most applicable species, and strains and gender of a species. Here are two examples:

- It would have been invaluable years ago for toxicologists and risk assessors to have known that carcinogenic effects in male rats are considered irrelevant for humans if the  $\alpha(2u)$ -globulin protein is involved because humans lack that protein. See [another example](#)
- Many physiological, pharmacological, and toxicological findings related to organic anion and cation transport and transporters in rodents and rabbits do not apply to humans. [Learn more](#)

In some cases, it may not be possible to use the most desirable animal for testing because of animal welfare or cost considerations.

- For example, use of dogs and non-human primates is now restricted to special cases or banned by some organizations, even though they represent the species that may respond the closest to humans in terms of chemical and other exposures (however, note the examples above).

Rodents and rabbits are the most commonly used laboratory species because they are readily available, inexpensive to breed and house, and they have a history of producing reliable results in experiments.

The toxicologist attempts to design an experiment to duplicate the potential exposure of humans as closely as possible. For example:

- The **route of exposure** should simulate that of human exposure. Most standard tests use inhalation, oral, or dermal routes of exposure.

- The **age of test animals** should relate to that of humans. Testing is normally conducted with young adults, although in some cases, newborn or pregnant animals may be used.
- For most routine tests, **both sexes** are used. Sex differences in toxic response are usually minimal, except for toxic substances with hormonal properties.
- **Dose levels** are normally selected so as to determine the threshold as well as a dose-response relationship. Usually, a minimum of three dose levels are used.



Figure 5.1.3. Rodents have commonly been used in animal testing

(Image Source: iStock Photos, ©)

### Acute Toxicity

Historically, **acute toxicity tests** were the first tests conducted. They provide data on the relative toxicity likely to arise from a single or brief exposure, or sometimes multiple doses over a brief period of time. Standardized tests are available for oral, dermal, and inhalation exposures, and many regulatory agencies still require the use of all or some of these tests. Table 5.1.1 lists basic parameters historically used in acute toxicity testing.

Category	Parameter
Species	Rats preferred for oral and inhalation tests; rabbits preferred for dermal tests
Age	Young adults
Number of animals	5 of each sex per dose level
Dosage	Three dose levels recommended; exposures are single doses or fractionated doses up to 24 hours for oral and dermal studies and 4-hour exposure for inhalation studies
Observation period	14 days

Table 5.1.1. Acute toxicity test parameter

### Subchronic Toxicity

**Subchronic toxicity tests** are employed to determine toxicity likely to arise from repeated exposures of several weeks to several months. Standardized tests are available for oral, dermal, and inhalation exposures. Detailed information is obtained during and after the study, ranging from body weight, food and water consumption measurements, effects on eyes and behavior, composition of blood, and microscopic examination of selected tissues and organs.

Table 5.1.2 lists basic parameters previously used in subchronic toxicity testing.

Category	Parameter
Species	Rodents (usually rats) preferred for oral and inhalation studies; rabbits for dermal studies; non-rodents (usually dogs) recommended as a second species for oral tests
Age	Young adults
Number of animals	10 of each sex for rodents; 4 of each sex for non-rodents per dose level
Dosage	Three dose levels plus a control group; includes a toxic dose level plus NOAEL; exposures are 90 days
Observation period	90 days (same as treatment period)

Table 5.1.2. Subchronic toxicity test parameter

### Chronic Toxicity

**Chronic toxicity tests** determine toxicity from exposure for a substantial portion of a subject's life. They are similar to the subchronic tests except that they extend over a longer period of time and involve larger groups of animals.

Table 5.1.3 includes basic parameters previously used in chronic toxicity testing.

Category	Parameter
Species	Two species recommended; rodent and non-rodent (rat and dog)
Age	Young adults
Number of animals	20 of each sex for rodents, 4 of each sex for non-rodents per dose level
Dosage	Three dose levels recommended; includes a toxic dose level plus NOAEL. The recommended maximum chronic testing durations for pharmaceuticals are now 6 and 9 months in rodents and non-rodents, respectively. (Historically exposures were for 12 months, 24 months for food chemicals.)
Observation period	12-24 months

Table 5.1.3. Chronic toxicity test parameter

### Carcinogenicity

**Carcinogenicity tests** are similar to chronic toxicity tests. However, they extend over a longer period of time and require larger groups of animals in order to assess the potential for cancer.

Table 5.1.4 lists basic parameters used in the past in carcinogenicity testing.

Category	Parameter
Species	Testing in two rodent species—rats and mice—is preferable given their relatively short life spans.
Age	Young adults
Number of animals	50 of each sex per dose level
Dosage	Three dose levels recommended; highest should produce minimal toxicity; exposure periods are at least 18 months for mice and 24 months for rats
Observation period	18-24 months for mice and 24-30 months for rats

Table 4. Carcinogenicity test parameter

### Reproductive Toxicity

**Reproductive toxicity testing** is intended to determine the effects of substances on gonadal function, conception, birth, and the growth and development of offspring. The oral route of administration is preferable.

Table 5.1.5 lists basic parameters historically used in reproductive toxicity testing.

Category	Parameter
Species	Rat is recommended
Age	Young adults
Number of animals	20 of each sex per dose level

Dosage	Three dose levels recommended; highest dose should produce toxicity but not mortality in parents; lowest dose should not produce toxicity
Observation period	Test substance given to parental animals (P1) prior to mating, during pregnancy, and through weaning of first generation (F1) offspring; substance then given to selected F1 offspring during their growth into adulthood, mating, and production of second generation (F2) until the F2 generation is 21 days old.

Table 5.1.5. Reproductive toxicity test parameter

### Developmental Toxicity

**Developmental toxicity** testing detects the potential for substances to produce embryotoxicity and birth defects.

Table 5.1.6 lists basic parameters previously used in developmental toxicity tests.

Category	Parameter
Species	Two species recommended; rat, mouse, hamster, and rabbit are used most commonly.
Age	Young adult females
Number of animals	20 pregnant females per dose level
Dosage	At least three dose levels are used; includes a toxic dose level plus NOAEL; occurs throughout organ development in the fetus for teratogenic effects; starts with parents prior to breeding, continues during pregnancy for all developmental effects
Observation period	Offspring sacrificed and examined the day prior to expected birth for teratogenic effects; offspring observed for growth retardation and abnormal function through infancy and examined for teratogenic effects

Table 5.1.6. Developmental toxicity test parameter

### Dermal Toxicity

**Dermal toxicity tests** determine the potential for an agent to cause irritation and inflammation of the skin. Those reactions may be a result of direct damage to the skin cells by a substance or an indirect response due to sensitization from prior exposure. *In vitro* approaches to dermal toxicity testing are being developed, in part because this type of testing has received so much publicity.

Table 5.1.7 lists basic parameters historically used in dermal toxicity testing.

Category	Parameter
Primary dermal irritation	Determines direct toxicity. The substance is applied to the skin of 6 albino rabbits for 4 hours and the rabbits are observed for 72 hours for irritation.
Dermal sensitization	Assays for immune hypersensitivity of the skin, consisting of two phases: 1) Application of the test substance to the skin of guinea pigs for 4 hours in the sensitization phase; and 2) a challenge phase at least 1 week later in which the substance is reapplied to the skin. An inflammatory reaction indicates that the skin has been sensitized to the substance.

Table 5.1.7. Dermal toxicity test parameter

### Ocular Toxicity

**Ocular toxicity** was at one time determined by applying a test substance for 1 second to the eyes of 6 test animals, usually rabbits. The eyes were then carefully examined for 72 hours, using a magnifying instrument to detect minor effects. An ocular reaction can occur on the cornea, conjunctiva, or iris. It may be simple irritation that is reversible and quickly disappears.

This eye irritation test was commonly known as the "**Draize Test.**" This test has received much attention, such as the development of a "**low volume**" variation and *in vitro* approaches.

### Neurotoxicity

A battery of **standardized neurotoxicity tests** were developed to supplement the **delayed neurotoxicity test** in domestic chickens (hens). The hen assay determines delayed neurotoxicity resulting from exposure to anticholinergic substances, such as certain pesticides. The hens are protected from immediate neurological effects of the test substance and observed for 21 days for delayed neurotoxicity.

Table 5.1.8 lists measurements included in other neurotoxicity tests.

Category	Parameter
Motor activity	Tests for decreased motor activity, such as cage movement. Rats or mice are used.
Peripheral nerve conduction	Tests for electrical conduction in motor and sensory nerves. Rodents are exposed to the test substance for 90 days.
Neuropathy	Tests for nerve damage by microscopic examination. This is one aspect of other standardized toxicity tests.

Table 5.1.8. Neurotoxicity test parameter

### Genetic Toxicity

**Genetic toxicity** is determined using a wide range of test species including whole animals and plants (*for example, rodents, insects, and corn*), microorganisms, and mammalian cells. A large variety of tests have been developed to measure gene mutations, chromosome changes, and DNA activity.

Table 5.1.9 lists parameters used for common gene mutation tests.

Category	Parameter
Microorganisms	<i>Salmonella typhimurium</i> and <i>Escherichia coli</i> are commonly used bacterial tests. The <i>S. typhimurium</i> assay is known as the Ames Test. Yeasts are also used to detect gene mutations in culture systems.
Mammalian cells	The two main cell lines are mouse lymphoma and Chinese hamster ovary (CHO) cells.
Fruit Flies	<i>Drosophila melanogaster</i> is used to detect sex-linked recessive lethal mutations.
Mice	The Mouse Specific-Locus Test is the major gene mutation test that employs whole animals. Exposed mice are bred and observed for hereditary changes.

Table 5.1.9. Genetic toxicity test parameter

**Chromosomal effects** can be detected with a variety of tests, some of which utilize entire animals (*in vivo*) and some which use cell systems (*in vitro*). Several assays are available to test for chemically induced chromosome aberrations in whole animals. Table



5.1.10 lists common *in vivo* means of testing chromosomal effects.

Category	Parameter
Rodent chromosomal assay	Involves exposure of mice or rats to a single dose of a substance. Their bone marrow is analyzed for chromosome aberrations over a 48-hour period.
Dominant lethal assay	Exposed male mice or rats are mated with untreated females. The presence of dead implants or fetuses is the result of the fertilized ovum receiving damaged DNA from the sperm. This leads to the death of the embryo or fetus. The genetic defect in the sperm is thus a heritable dominant lethal mutation.
Micronucleus test	Mice are exposed once and their bone marrow or peripheral blood cells are examined for 72 hours for the presence of micronuclei, such as broken pieces of chromosomes surrounded by a nuclear membrane.
Heritable translocation assay	Exposed male <i>Drosophila</i> or mice are bred to non-exposed females. The offspring males (F1 generation) are then bred to detect chromosomal translocations.
Sister chromatid exchange assay (SCE)	Mice are exposed to a substance and their bone marrow cells or lymphocytes are examined microscopically for complete chromosomal damage. This is indicated by chromatid fragments joining sister chromatids rather than their own.

Table 5.1.10 Chromosomal effects (*In vivo*) test parameter

### In Vitro Testing

*In vitro* tests for chromosomal effects involve exposure of cell cultures and followed by microscopic examination of them for chromosome damage.

The most commonly used cell lines are Chinese Hamster Ovary (CHO) cells and human lymphocyte cells. The CHO cells are easy to culture, grow rapidly, and have a low chromosome number (22), which makes for easier identification of chromosome damage.

Human lymphocytes are more difficult to culture. They are obtained from healthy human donors with known medical histories. The results of these assays are potentially more relevant to determine effects of xenobiotics that induce mutations in humans.

Two widely used genotoxicity tests measure DNA damage and repair that is not mutagenicity. DNA damage is considered the first step in the process of mutagenesis. Common assays for detecting DNA damage include:

1. **Unscheduled DNA synthesis (UDS)** — involves exposure of mammalian cells in culture to a test substance. UDS is measured by the uptake of tritium-labeled thymidine into the DNA of the cells. Rat hepatocytes or human fibroblasts are the mammalian cell lines most commonly used.
2. **Exposure of repair-deficient *E. coli* or *B. subtilis*** — DNA damage cannot be repaired so the cells die or their growth may be inhibited.

### Emerging Approaches and Methods

In the future, there will likely be additional and refined *in vitro* methods, and the emergence of *in silico* and "chip" approaches.

Many current efforts are underway to refine, develop, and validate *in vitro* methods.

### Did you know?

The Human Toxicology Project Consortium provides a video series called [Pathways to a Better Future](#). These videos discuss the future of toxicology, if you would like to know more about where the field is headed.

## In Silico Methods

Also emerging are *in silico* methods, meaning "performed on computer or via computer simulation." This term was developed as an analogy to the Latin phrases *in vivo* and *in vitro*.

Advanced computer models called "Virtual Tissue Models" are being developed by the U.S. [EPA's National Center for Computational Toxicology \(NCCT\)](#). The EPA's Virtual Tissue Models are described as using "new computational methods to construct advanced computer models capable of simulating how chemicals may affect human development. Virtual tissue models are some of the most advanced methods being developed today. The models will help reduce dependence on animal study data and provide much faster chemical risk assessments" ([source](#)).

One example is the Virtual Embryo ([v-Embryo](#)<sup>TM</sup>) research effort, aimed at developing prediction models to increase our understanding of how chemical exposure may affect unborn children. Researchers are integrating new types of *in vitro*, *in vivo*, and *in silico* models that simulate critical steps in fetal development. Virtual Embryo models simulate biological interactions observed during development and predict chemical disruption of key biological events in pathways that is believed to lead to adverse effects.

v-Embryo logo from EPA

Figure 5.1.4. *v-Embryo* logo

## "Chip" Models

Also emerging are microphysiological systems (MPS) that are used in "tissue chip" and "organs-on-chips" models. Chip models include human cell cultures that are placed on a computer chip and studied there. The [Wyss \(pronounced "Veese"\) Institute for Biologically Inspired Engineering](#) is a helpful resource for more information.

For example, the "Lung-on-a-chip" is described as "combining microfabrication techniques with modern tissue engineering, lung-on-a-chip offers a new *in vitro* approach to drug screening by mimicking the complicated mechanical and biochemical behaviors of a human lung." To learn more, watch a [video](#) from the Wyss Institute that shows a human lung-on-a-chip. [Another Wyss Institute video](#) illustrates how researchers have used long-on-a-chip to mimic pulmonary edema.

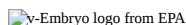
A human hand is shown holding the computer chip containing lung data.

Figure 5.1.5. *Lung-on-a-chip* used to mimic pulmonary edema  
(Image Source: [The Wyss Institute for Biologically Inspired Engineering](#))

Using a connected series of tissue chips as an integrated multi-organ system can allow for the creation of a "[human-on-a-chip](#)," to be used to model the metabolism and effects of drugs and other substances moving through a human. For example, a liver chip could provide fluids and metabolites to a kidney chip, allowing for the assessment of the nephrotoxic (kidney damage) potential of a substance metabolized in the liver.

## Induced Pluripotent Stem Cells (iPSCs)

Induced pluripotent stem cells (iPSCs) are an emerging approach using *in vitro* cultures of cells. The cells of mammals and plants can be reprogrammed via "cellular reprogramming" to generate iPSCs. Like human embryonic stem cells, iPSCs are pluripotent (capable of giving rise to several different cell types) and these cells can renew themselves. As examples, iPSC-derived hepatocytes, cardiomyocytes, and neural cells can serve as tools for the screening of drugs and other substances for potential toxicity, and also can be used to study disease mechanisms and pathways. Further, iPSCs have been studied in immunotherapy and regenerative cellular therapies.

Schematic representation of how somatic cells taken from a patient can be reprogrammed into induced pluripotent stem cells (iPSCs) using the 'Yamanaka' factors, OCT4, KLF4, c-MYC and SOX2. Subsequent differentiation of human iPSCs (hiPSCs) into neurons of define lineage allow for investigations into disease pathophysiology and identification of potential drug targets. In addition, hiPSC derived neurons may function as a cellular platform in which drug screens can be carried out using disease relevant neurons.

Figure 5.1.6. *Promise of hiPSCs*. Schematic representation of how somatic cells taken from a patient can be reprogrammed into induced pluripotent stem cells (iPSCs) using the 'Yamanaka' factors, OCT4, KLF4, c-MYC and SOX2. Subsequent differentiation of human iPSCs (hiPSCs) into neurons of define lineage allow for investigations into disease pathophysiology and identification of potential drug targets. In addition, hiPSC derived neurons may function as a cellular platform in which drug screens can be carried out using disease relevant neurons.

(Image Source: [Adapted under Creative Commons Attribution License \(CC BY\)](#)).

doi: [10.1016/j.yhbeh.2015.06.014](https://doi.org/10.1016/j.yhbeh.2015.06.014)

Original image: <https://www.ncbi.nlm.nih.gov/pmc/articles/PMC4579404/figure/f0005/>)

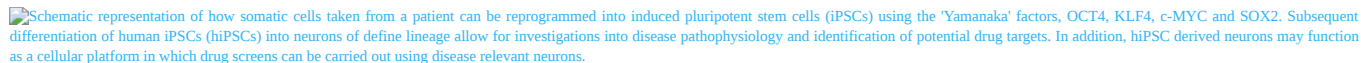
### Did you know?

Professor Shinya Yamanaka (Kyoto University, Japan) received the 2012 Nobel Prize in Physiology or Medicine for discovering that mature cells can be reprogrammed to iPSCs that can differentiate into any type of cell. Key to this discovery was his use of four "reprogramming factors" referred to as c-Myc, Klf4, Oct3/4, and Sox2.

### Learn more

#### Combining "Chips" and iPSCs

The emerging approaches of "chips" and iPSCs are being combined. One example is for the evaluation of drugs as potential countermeasures for biological and chemical threats that can be a substitute for human clinical trials. The "chips" and "humans on a chip" can be used as complex *in vitro* human models to simulate the biology and function of an organ.

---

This page titled [5.1: Testing and Assessing Toxicity](#) is shared under a [CC BY-NC 4.0](#) license and was authored, remixed, and/or curated by [ToxMSDT Online component](#) via [source content](#) that was edited to the style and standards of the LibreTexts platform.

## 5.2: Clinical Investigations and Other Types of Human Data

### For Drugs

The focus of this section is on the U.S. Food and Drug Administration (FDA), but regulatory agencies worldwide have very similar approaches. The main methods of determining the toxicity of drugs to humans are:

- **Clinical investigations** — administration of chemicals to human subjects with careful clinical observations and laboratory measurements.
- **Epidemiological studies** — observation of humans who have been exposed to xenobiotics in the normal course of their life or occupation.
- **Adverse reactions to drug reports** — reports voluntarily submitted by physicians to the FDA after a drug has been approved and is in widespread use.



Figure 5.2.1. Drugs can be toxic to humans  
(Image Source: iStock Photos, ©)

### Clinical Investigations

**Clinical investigations** are a component of **Investigational New Drug Applications (INDs)** submitted to the FDA. Clinical investigations are conducted only after a minimal battery of nonclinical laboratory studies has been completed.

Toxicity studies using human subjects require strict ethical considerations. They are primarily conducted for new pharmaceutical applications submitted to the FDA for approval.

Generally, toxicity found in animal studies occurs with similar incidence and severity in humans. Differences sometimes occur, thus clinical tests with humans are needed to confirm the results of nonclinical laboratory studies.

FDA clinical investigations are conducted in three phases, as outlined below.



Figure 5.2.2 *Portion of the Investigational New Drug Application (IND)*  
(Image Source: FDA)

**Phase 1** consists of testing the drug in a small group of 20 to 80 healthy volunteers. Information obtained in Phase 1 studies is used to design Phase 2 studies, in particular, to determine the drug's:

- Initial tolerability in human subjects.
- Pharmacokinetics and pharmacological effects.



**Phase 2** studies are more extensive, involving several hundred patients and are used to:

- Determine the short-term side effects of the drug.
- Determine the risks associated with the drug.
- Evaluate the effectiveness of the drug for treatment of a particular disease or condition.
- Elucidate the drug's metabolism.



**Phase 3** studies are **controlled** and uncontrolled trials conducted with several hundred to several thousand patients. They are designed to:

- Gather additional information about effectiveness and safety.
- Evaluate overall risk:benefit profile of the drug.
- Provide the basis for the precautionary information that accompanies the drug.



## For Consumer Products

Health-related data for a chemical in a consumer product (and for the consumer product itself for the human studies) can come from the following types of studies:

- *In silico* data — from computer programs that estimate toxic properties based on data for similar chemicals, and/or from the physical chemical properties.
- *In vitro* data — from the results of alternatives to animal tests, such as from cell cultures used to assess the potential for eye or skin irritation.
- Animal (toxicological) study data — for example, from studies that assessed eye or skin irritation potential.
- Human data – from studies conducted before (**premarketing**) and after (**postmarketing**) a product had been sold to consumers. More specifically, from:
  - Premarketing **clinical studies**, such as from patch tests to assess skin irritation potential.
  - Premarketing "**controlled use**" studies that are designed to assess the skin effects from using a new type of personal care product.
  - Postmarketing **studies conducted by physicians or dermatologists**, such as testing a diagnostic patch with their patients.
  - Postmarketing **epidemiological studies**, including studies developed by Poison Control Centers, companies, and academia that look at the "real world" health reports of effects associated with consumer use of a product.



Figure 5.2.3. Toxicologists in a lab, using a computer for research

(Image Source: iStock Photos, ©)

### Did you know?

**Bisphenol A (BPA)** and **phthalates** are chemicals that have been widely found in consumer products. BPA has been used in some food can linings, polycarbonate food and beverage containers, tooth sealants applied to dentists, and even in cash register receipts! Examples of potential exposures to BPA include eating or drinking foods or liquids from those containers, and skin exposures from handling the cash register receipts. Workers involved in making products with BPA can be exposed during production.

Often called plasticizers, phthalates are used to make plastics more flexible. Some phthalates are used as solvents. They can be found in vinyl flooring and shower curtains, children's toys, personal care products, and as contaminants in the food supply. As with BPA, exposures can come from many sources.

Toxicologists and others are still assessing the full extent of the potential impacts on health. Studies suggest that BPA and phthalates affect the reproductive system, impacting how hormones such as estrogen and testosterone work in the body. The impact of fetal or early childhood exposures is still being assessed. Because of the ubiquity of the possible products containing these chemicals, thorough assessments of potential exposures, toxicities, and potential substitutes are essential.



Figure 5.2.4. Plastic food and beverage containers are common sources of BPA and phthalates in consumer products

(Image Source: iStock Photos, ©)

---

This page titled [5.2: Clinical Investigations and Other Types of Human Data](#) is shared under a [CC BY-NC 4.0](#) license and was authored, remixed, and/or curated by [ToxMSDT Online component](#) via [source content](#) that was edited to the style and standards of the LibreTexts platform.

## 5.3: Epidemiology Studies

### What Are Epidemiology Studies?

Epidemiology studies are conducted using human populations to evaluate whether there is a **correlation or causal relationship** between exposure to a substance and adverse health effects.

These studies differ from clinical investigations in that individuals have already been administered the drug during medical treatment or have been exposed to it in the workplace or environment.

Epidemiological studies measure the risk of illness or death in an exposed population compared to that risk in an identical, unexposed population (for example, a population the same age, sex, race and social status as the exposed population).



Figure 5.3.1. Epidemiology studies tend to produce graphs and charts for data analysis and presentation (Image Source: Adapted from iStock Photos, ©)

### Types of Studies

There are four primary types of epidemiology studies. They are:

1. **Cohort studies** — A cohort (group) of individuals with exposure to a chemical and a cohort without exposure are followed over time to compare disease occurrence.
2. **Case control studies** — Individuals with a disease (such as cancer) are compared with similar individuals without the disease to determine if there is an association of the disease with prior exposure to an agent.
3. **Cross-sectional studies** — The prevalence of a disease or clinical parameter among one or more exposed groups is studied, such as:
  - The prevalence of respiratory conditions among furniture makers.
4. **Ecological studies** — The incidence of a disease in one geographical area is compared to that of another area, such as:
  - Cancer mortality in areas with hazardous waste sites as compared to similar areas without waste sites.

### Cohort Studies

Cohort studies are the most commonly conducted epidemiology studies and they frequently involve occupational exposures. Exposed persons are easy to identify and their exposure levels are usually higher than in the general public. There are two types of cohort studies:

1. **Prospective**, in which cohorts are identified based on current exposures and followed into the future.
2. **Retrospective**, in which cohorts are identified based on past exposure conditions and study "follow-up" proceeds forward in time; data come from past records.

### Common Statistical Measures

Standard, quantitative measures are used to determine if epidemiological data are meaningful. The most commonly used measures are:

- **Odds Ratio (O/R)** — The ratio of risk of disease in a case-control study for an exposed group to an unexposed group. An odds ratio equal to 2 ( $O/R = 2$ ) means that the exposed group has twice the risk as the non-exposed group.
- **Standard Mortality Ratio (SMR)** — The relative risk of death based on a comparison of an exposed group to non-exposed group. A standard mortality ratio equal to 150 ( $SMR = 150$ ) indicates that there is a 50% greater risk.
- **Relative Risk (RR)** — The ratio expressing the occurrence of disease in an exposed population to that of an unexposed population. A relative risk of 175 ( $RR = 175$ ) indicates a 75% increase in risk.

### Study Design

When designing an epidemiology study, the most critical aspects include:

- An appropriate control group.
- An adequate time span.

- The statistical ability to detect an effect.

More specifically, the control population used as a comparison group must be as similar as possible to that of the test group, for example, same age, sex, race, social status, geographical area, and environmental and lifestyle influences.

Many epidemiology studies evaluate the potential for an agent to cause cancer. Because most cancers require long latency periods, the study must cover that period of time.

The statistical ability to detect an effect is referred to as the **power** of the study. To gain precision, the study and control populations should be as large as possible.

## Bias Errors

Epidemiologists attempt to control errors that can occur in the collection of data, which are known as bias errors. The three main types of bias errors are:

1. **Selection bias**, which occurs when the study group is not representative of the population from which it came.
2. **Information bias**, which occurs when study subjects are misclassified as to disease or exposure status. Recall bias occurs when individuals are asked to remember exposures or conditions that existed years before.
3. **Confounding factors**, which occur when the study and control populations differ with respect to factors which might influence the occurrence of the disease. For example, smoking might be a confounding factor and should be considered when designing studies.

## Postmarketing Studies

Finally, for consumer products, **postmarketing** epidemiological studies can be performed. Examples include studies developed by Poison Control Centers, companies, academia, and other sources to look at the "real world" health reports of effects associated with consumer use of a product or article under reasonably foreseeable conditions.

### Knowledge Check

While animal testing was historically the primary method used in testing for toxicity, modern testing methods prefer:

- In silico*
- In vitro*
- Refined animal testing
- All of the above

#### Answer

All of the above - **This is the correct answer.**

Modern approaches to testing for toxicity include *in silico*, *in vitro*, and improved (refined) animal testing.

In testing a pharmaceutical to comply with FDA requirements, the initial testing consists of:

- Clinical investigations
- Non-clinical laboratory studies
- Epidemiology studies
- All of the above

#### Answer

Non-clinical laboratory studies - **This is the correct answer.**

Investigational New Drug Applications (IND) require clinical investigations. Before clinical investigations begin, a minimal battery of non-clinical laboratory studies must be completed.

The primary goal of a Phase 1 clinical investigation is to:

- Obtain information to design a more definitive Phase 2 clinical investigation

- Evaluate the effectiveness of a drug for treating disease
- Provide the basis for pharmaceutical labeling

**Answer**

Obtain information to design a more definitive Phase 2 clinical investigation - **This is the correct answer.**

The primary goal of a Phase 1 clinical investigation is to obtain information that is used to design more extensive, Phase 2 studies.

Determining the overall risk versus the benefit of a new pharmaceutical is part of:

- Phase 2 clinical investigation
- Phase 3 clinical investigation
- Epidemiology study

**Answer**

Phase 3 clinical investigation - **This is the correct answer.**

Determining the overall risk versus the benefit of a new pharmaceutical is part of Phase 3 clinical study. The risk versus benefit is one of the last steps in the drug evaluation process.

The type of epidemiology study in which individuals are identified according to exposure and followed to determine subsequent disease risk is known as:

- Cohort study
- Case control study
- Cross-sectional study
- Ecological study

**Answer**

Cohort study - **This is the correct answer.**

The type of epidemiology study in which individuals are identified according to exposure and followed to determine subsequent disease risk is known as a cohort study. In a cohort study individuals are selected to be part of the group based on their exposure to a particular substance.

An epidemiological study in which the individuals that make up the test cohort are identified according to past exposures is known as:

- Case control study
- Prospective cohort study
- Retrospective cohort study

**Answer**

Retrospective cohort study - **This is the correct answer.**

This is known as a retrospective cohort study. As the name implies, retrospective cohorts are identified according to past exposure conditions and the follow-up study proceeds forward in time.

This page titled [5.3: Epidemiology Studies](#) is shared under a [CC BY-NC 4.0](#) license and was authored, remixed, and/or curated by [ToxMSDT Online component](#) via [source content](#) that was edited to the style and standards of the LibreTexts platform.



## CHAPTER OVERVIEW

### Section 6: Risk Assessment

#### Learning Objectives

After completing this lesson, you will be able to:

- Identify the basic steps in the risk assessment process.
- Explain the framework for risk-based decision-making.
- Describe methods for identifying hazards.
- Explain methods for toxicity assessment, including dose-response and exposure.

#### In this section...

Topics include:

- [6.1: Risk Assessment](#)
- [6.2: Hazard Identification](#)
- [6.3: Dose-Response Assessment](#)
- [6.4: Exposure Assessment](#)
- [6.5: Risk Characterization](#)

## What We've Covered

This section made the following main points:

- A **hazard** is the capability of a substance to cause an adverse effect.  
A **risk** is the probability that the hazard will occur under specific conditions.
- **Risk assessment** is the process of determining hazard, exposure, and risk.  
**Risk management** is the process of weighing policy alternatives and deciding on the most appropriate regulatory action.
- There are **four basic steps to risk assessment**:
  1. **Hazard Identification**
    - Identify or develop information suggesting or confirming whether a chemical poses a potential hazard to humans.
    - (Quantitative) Structure Activity, or (Q)SAR methods, including computer models, help consider closely related chemicals as a group or category.
    - Read-across involves estimating what a chemical may be like, including the presence or absence of certain properties or activities, based on one or more other chemicals.
    - Adverse Outcome Pathways (AOPs) involve *in vitro* methods that evaluate changes in normal cellular signaling pathways.
    - Other emerging methods include (Quantitative) *in vitro* to *in vivo* extrapolation, or (Q)IVIVE, Integrated Testing Strategies, and Integrated Approaches to Testing and Assessment (IATA).
  2. **Dose-Response Assessment**
    - Carcinogenic (cancer) risk assessment involves two steps:
      1. Perform qualitative evaluation of all epidemiology studies, animal bioassay data, and biological activity.
      2. Quantitation of the risk for substances classified as definite or probably human carcinogens.
    - Non-carcinogenic risk assessment includes:
      - Acceptable Daily Intake (ADI), which divides the NOAEL by uncertainty/safety factors.
      - Reference Dose (RfD), which divides the NOAEL or LOAEL by uncertainty/safety factors.
      - Benchmark Dose Method (BMD), which extrapolates data to determine a point of departure (POD) that accounts for study quality.
      - Assessments for noncancer toxicity effects, acute or short-term exposures, and occupational exposures.

### 3. Exposure Assessment

- People are exposed to mixtures of hundreds of chemicals in everyday life.
- An **exposure pathway** describes the:
  - Route a substance takes from its source to its endpoint.
  - How people can be exposed to the substance.
- The three steps of exposure assessment are to:
  1. Characterize the point of exposure setting and exposure scenario.
  2. Identify exposure pathways.
  3. Quantify the exposure.
- Exposure models are commonly used because actual exposure measurements are often not available.

### 4. Risk Characterization

- This final phase predicts the frequency and severity of effects in exposed populations.
- Biological and statistical uncertainties are described.
- For carcinogenic risks, the probability of a person developing cancer over a lifetime is estimated by multiplying the cancer slope factor for the substance by the chronic, 70-year average daily intake.
- For noncarcinogenic effects, the exposure level is compared with an ADI, RfD, or MRL derived for similar exposure periods.

---

This page titled [Section 6: Risk Assessment](#) is shared under a [CC BY-NC 4.0](#) license and was authored, remixed, and/or curated by [ToxMSDT Online component](#) via [source content](#) that was edited to the style and standards of the LibreTexts platform.

## 6.1: Risk Assessment

### Did you know?

For many years, the terminology and methods used in human risk or hazard assessment were inconsistent, which led to confusion among scientists, the public, and others.

 Illustration of a magnifying glass over the word 'Risk'

(Image Source: iStock Photos, ©)

### "Red Book" for Risk Assessment (1983)

In 1983, the (U.S.) National Academy of Sciences (NAS) published **Risk Assessment in the Federal Government: Managing the Process**. Often called the "Red Book" by toxicologists and others, it addressed the standard terminology and concepts for risk assessments.

 Cover of the publication, 'Risk Assessment in the Federal Government: Managing the Progress,' commonly known as the 'Red Book'

Figure 6.1.1. Toxicology-based approaches to hazard identification, dose-response assessment, exposure analysis, and characterization of risks were described in the 1983 Red Book

(Image Source: National Academies Press)

### Key Terms

The following terms are routinely used in risk assessments:

- **Hazard** — capability of a substance to cause an adverse effect.
- **Risk** — probability that the hazard will occur under specific exposure conditions.
- **Risk assessment** — the process by which hazard, exposure, and risk are determined.
- **Risk management** — the process of weighing policy alternatives and selecting the most appropriate regulatory action based on the results of risk assessment and social, economic, and political concerns.

### Risk Assessment Steps

The four basic steps in the risk assessment process as defined by the NAS are:

1. **Hazard identification** — characterization of innate adverse toxic effects of agents.
2. **Dose-response assessment** — characterization of the relation between doses and incidences of adverse effects in exposed populations.
3. **Exposure assessment** — measurement or estimation of the intensity, frequency, and duration of human exposures to agents.
4. **Risk characterization** — estimation of the incidence of health effects under the various conditions of human exposure.

Once risks are characterized in step 4, the process of risk management begins (Figure 2).

 Illustration of the relationship between risk assessment and risk management, each represented by a circle that overlaps. The circle on the left represents risk assessment and begins with hazard identification, followed by dose-response assessment and exposure assessment, each leading to the overlapping portion of risk characterization. The circle on the right represents risk management. Control alternatives, determination of the acceptable risk level, and outcomes of risk characterization lead to control decision. A feedback loop also connects from risk management to risk assessment.

Figure 6.1.2 *Interaction between processes of risk assessment and risk management*

(Image Source: ORAU, ©)

### "Silver Book" for Advancing Risk Assessment (2009)

A newer book by the NAS, **Science and Decisions: Advancing Risk Assessment** (2009), often called the "Silver Book" by toxicologists and others, emphasizes uncertainty and variability and cumulative risk, and notes that risk assessment "is at a crossroads."

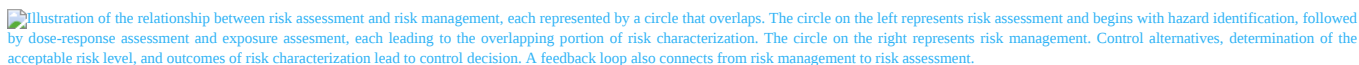
 Cover of the publication, 'Science and Decisions: Advancing Risk Assessment,' commonly called the 'Silver Book'

Figure 6.1.3 *The 2009 Silver Book includes approaches for improving risk analysis and a framework for risk-based decision-making*

(Image Source: National Academies Press)

## Risk-Based Decision Making

The co-authors of this Silver Book proposed a framework for risk-based decision-making (Figure 4). The framework consists of three phases:

**Enhanced problem formulation and scoping** — available risk-management options are identified.

 Phase 1 - Enhanced problem formulation and scoping

**Planning and assessment** — risk-assessment tools are used to determine risks under existing conditions and under potential risk-management options.

 Phase 2 - Planning and assessment

**Risk management** — risk and non-risk information is integrated to inform choices among options.

 Phase 3 - Risk management

The core of the framework, as noted in the Silver Book, includes the risk assessment paradigm of the Red Book, but differs primarily in its initial and final steps:

- "The framework systematically identifies problems and options that risk assessors should evaluate at the earliest stages of decision-making."
- "It expands the array of impacts assessed beyond individual effects (for example, cancer, respiratory problems, and individual species) to include broader questions of health status and ecosystem protection."
- "It provides a formal process for stakeholder involvement throughout all stages but has time constraints to ensure that decisions are made."
- "It increases understanding of the strengths and limitations of risk assessment by decision-makers at all levels, for example, by making uncertainties and choices more transparent."

 The framework for risk-based decision-making includes three phases: problem formulation and scoping, planning and conduct of risk assessment, and risk management. Stage 1 involves planning, stage 2 involves risk assessment, and stage 3 is confirmation of utility. There are formal provisions for internal and external stakeholder involvement at all stages.

Figure 6.1.4 *Framework for risk-based decision-making*

(Source: "Silver Book," chapter 8)

## Latest Approaches

Other parts of ToxTutor highlight the latest approaches used in risk assessment. For example:

- **Hazard Identification** describes the emerging approach to hazard identification called **Adverse Outcome Pathways (AOPs)**.
- **Testing for, and Assessing Toxicity** describes the numerous global efforts made, since approximately 1990, to reduce and replace use of laboratory animals in toxicology studies. Included are efforts to develop and validate *in vitro* methods and the emerging use of *in silico* methods.

### Knowledge Check

Risk is the:

- Capability of a substance to cause an adverse effect
- Weighing of possible alternatives and selecting the most appropriate regulatory actions
- Probability that a hazard will occur under specific exposure conditions

#### Answer

Probability that a hazard will occur under specific exposure conditions - **This is the correct answer.**  
Risk is the *probability* that a hazard will occur.

In the risk assessment process, what happens during the hazard identification step?

- Characterization of the relation between doses and incidences of adverse effects
- Characterization of innate adverse toxic effects of agents
- Measurement or estimation of intensity, frequency, and duration of human exposures to agents

- Estimation of the incidence of health effects under the various conditions of human exposure

**Answer**

Characterization of innate adverse toxic effects of agents - **This is the correct answer.**

Hazard identification is the first step in the risk assessment process as defined by the National Academy of Sciences.

What are the phases of the risk-based decision-making framework proposed by the co-authors of the "Silver Book?"

- Enhanced problem formulation and scoping; planning and assessment; and risk management
- Hazard identification; dose-response assessment; exposure assessment; risk characterization
- Hazard identification; risk assessment; action planning

**Answer**

Enhanced problem formulation and scoping; planning and assessment; and risk management - **This is the correct answer.**

The framework proposed by the co-authors of the "Silver Book" involves enhanced problem formulation and scoping; planning and assessment; and risk management.

---

This page titled [6.1: Risk Assessment](#) is shared under a [CC BY-NC 4.0](#) license and was authored, remixed, and/or curated by [ToxMSDT Online component](#) via [source content](#) that was edited to the style and standards of the LibreTexts platform.

## 6.2: Hazard Identification

The goal of hazard identification in toxicology is to identify or develop information suggesting or confirming that a chemical (or, for example, a consumer product) poses or does not pose a potential hazard to humans.

During earlier years of toxicology, this process relied primarily on human epidemiology data and on various types of animal testing data, supplemented in more recent years with the development of *in vitro* methods such as those focused on assessing the potential for mutations and DNA damage. The future of hazard identification is promising and toxicologists now have various types of *in vitro* methods to explore for hazard identification, along with the emergence of "chip" approaches.

 Hazard identification is the first step in Risk Assessment

Figure 6.2.1. Hazard identification is the first component of risk assessment  
(Image Source: ORAU, ©)

These emerging methods are based, in part, on **(Quantitative) Structure Activity, or (Q)SAR methods**. Q(SAR) methods, such as computer models, help toxicologists and others to consider closely related chemicals as a group, or chemical category, rather than as individual chemicals. Not every chemical needs to be tested for every toxicity endpoint, and the data for chemicals and endpoints that have been tested are used to estimate the corresponding properties for other chemicals and endpoints of interest. Data from a chemical category must be judged as adequate to support at least a "screening-level" hazard identification.

One approach involves using endpoint information for one chemical to predict the same endpoint for another chemical that is considered "similar" in some way (such as having structural similarity and similar properties and/or activities).

### Read-Across

Another approach for hazard identification used since about 2000 is **read-across**. Read-across can be qualitative or quantitative:

- In **qualitative read-across**, the presence (or absence) of a property/activity such as a particular type of toxic effect for the chemical of interest is inferred from the presence (or absence) of the same property/activity for one or more other chemicals. This qualitative approach provides a "yes/no" answer.
- **Quantitative read-across** uses information for one or more chemicals to estimate what the chemical of interest will be like. Thus, quantitative read-across can be used to obtain a quantitative value for an endpoint, such as a dose-response relationship.

### Adverse Outcome Pathways (AOPs)

An emerging approach to hazard identification is the use of **Adverse Outcome Pathways (AOPs)**. AOPs reflect the move in toxicity testing from high-dose studies in laboratory animals to *in vitro* methods that evaluate changes in normal cellular signaling pathways using human-relevant cells or tissues. The AOP concept has emerged as a framework for connecting high throughput toxicity testing (HTT, or high throughput toxicity screening, HTS) and other results.

#### AOP Learning Channel

The **Human Toxicology Project Consortium** provides a collection of informational videos about AOPs for your further exploration. These videos are available on the **AOP Learning Channel**.

### Other Computer Models

Another emerging term is **(quantitative) *in vitro* to *in vivo* extrapolation, or (Q)IVIVE**, used together with what are being called **Integrated Testing Strategies** and Integrated Approaches to Testing and Assessment (IATA).

#### Toxicology Testing in the 21st Century - A New Strategy

The High Throughput Screening (HTS) Initiative is part of the new toxicology testing strategy developed from the 2004 National Toxicology Program (NTP) **Vision and Roadmap for the 21st Century**.

Traditional toxicological testing is based largely on the use of laboratory animals. However, this approach suffers from low throughput, high cost, and difficulties inherent to inter-species extrapolation – making it of limited use in evaluating the very large number of chemicals with inadequate toxicological data.

NTP recognized that the dramatic technological advances in molecular biology and computer science offered an opportunity to use *in vitro* biochemical- and cell-based assays and non-rodent animal models for toxicological testing. These assays allow for much

higher throughput at a much reduced cost. In some assays, many thousands of chemicals can be tested simultaneously in days.

The goal is to move toxicology from a predominantly observational science at the level of disease-specific models to a predominantly predictive science focused upon broad inclusion of target-specific, mechanism-based, biological observations.

The High Throughput Screening program represents a new paradigm in toxicological testing. The HTS program approach to toxicological testing screens for mechanistic targets active within cellular pathways considered critical to adverse health effects such as carcinogenicity, reproductive and developmental toxicity, genotoxicity, neurotoxicity, and immunotoxicity in humans.

 National Toxicology Program, A National Toxicology Program for the 21st Century

Figure 6.2.2 *National Toxicology Program vision and roadmap*  
(Image Source: National Toxicology Program)

### Goals of the HTS Program

- To prioritize substances for further in-depth toxicological evaluation.
- To identify mechanisms of action for further investigation (for example, disease-associated pathways).
- To develop predictive models for *in vivo* biological response (predictive toxicology).

### Reference:

National Toxicology Program. (2016, March 21). *Tox 21*. U.S. Department of Health and Human Services. Retrieved from <http://ntp.niehs.nih.gov/results/tox21/index.html>

As described in the [Testing for, and Assessing Toxicity](#) section, the EPA is developing "Virtual Tissue Models" such as the Virtual Embryo (v-Embryo™). These types of advanced computer models are being designed to be capable of simulating how chemicals may affect human development and will help reduce dependence on animal study data. They will also provide faster ways of developing chemical risk assessments.

Finally, also noted in the *Testing for and Assessing Toxicity* section, emerging in the toxicologist's tool box are "chip" models (for example, an "organ on a chip"). One example is the "Lung-on-a-chip" that "...offers a new *in vitro* approach to drug screening by mimicking the complicated mechanical and biochemical behaviors of a human lung."

 A human hand is shown holding the computer chip containing lung data.

Figure 6.2.3 *Lung-on-a-chip used to mimic pulmonary edema*  
(Image Source: The Wyss Institute for Biologically Inspired Engineering)

### Knowledge Check

- Extensive animal testing for toxicity
- Computer models like (Q)SAR
- Risk assessment strategies

### Answer

Computer models like (Q)SAR - **This is the correct answer.**

Part of the basis for emerging approaches to hazard identification, such as assessing for potential mutations and DNA damage, relies on (Quantitative) Structure Activity (Q)SAR methods.

Adverse Outcome Pathways (AOPs) are methods of hazard identification that:

- Evaluate changes in normal cellular signaling pathways using human-relevant cells or tissues
- Identify adverse outcomes in test subjects administered increasing doses of potential toxicants
- Measure the intensity, frequency, and duration of human exposures to agents
- Evaluate the health effects under various conditions of human exposure

### Answer

Evaluate changes in normal cellular signaling pathways using human-relevant cells or tissues - **This is the correct answer.**

Adverse Outcome Pathways (AOPs) are *in vitro* methods that evaluate changes in normal cellular signaling pathways using

human-relevant cells or tissues.

Can quantitative read-across be used to determine the value of an endpoint, such as dose-response relationship?

- Yes
- No

**Answer**

Yes - **This is the correct answer.**

Quantitative read-across can lead to a measurable value for an endpoint, such as a dose-response relationship.

---

This page titled [6.2: Hazard Identification](#) is shared under a [CC BY-NC 4.0](#) license and was authored, remixed, and/or curated by [ToxMSDT Online component](#) via [source content](#) that was edited to the style and standards of the LibreTexts platform.



## 6.3: Dose-Response Assessment

### Dose-Response Assessment

The dose-response assessment step of the risk assessment process quantitates the hazards that were identified in the previous step. It determines the relationship between dose and incidence of effects in humans. There are normally two major extrapolations required:

1. From high experimental doses to low environmental doses.
2. From animal doses to human doses.

The procedures used to extrapolate from high to low doses are different for assessing carcinogenic effects and noncarcinogenic effects:

- **Carcinogenic effects** in general are not considered to have a threshold and mathematical models are generally used to provide estimates of carcinogenic risk at very low dose levels.
- **Noncarcinogenic effects** (for example *neurotoxicity*) are considered to have dose thresholds below which the effect does not occur. The lowest dose with an effect in animal or human studies is divided by safety factors to provide a margin of safety.

 Risk assessment and risk management process, with the dose-response assessment phase highlighted

Figure 6.3.1. Dose-response assessment is a step in the risk assessment process  
(Image Source: ORAU, ©)

### Carcinogen (Cancer) Risk Assessment

**Cancer risk assessment** involves two steps:

1. **Perform qualitative evaluation of all epidemiology studies, animal bioassay data, and biological activity (for example, mutagenicity).** The substance is classified as to its carcinogenic risk to humans based on the weight of evidence. If the evidence is sufficient, the substance may be classified as a definite, probable or possible human carcinogen.
2. **Quantitate the risk for those substances classified as definite or probable human carcinogens.** Mathematical models are used to extrapolate from the high experimental doses to the lower environmental doses.

The two primary cancer classification schemes are those of the **Environmental Protection Agency** (EPA) and the **International Agency for Research on Cancer** (IARC). The EPA and IARC classification systems are quite similar.

#### 1. Qualitative Evaluation of Cancer Risk

The EPA's cancer assessment procedures have been used by several Federal and State agencies. The Agency for Toxic Substances and Disease Registry (ATSDR) relies on EPA's carcinogen assessments. A substance is assigned to one of five descriptors shown below in Table 6.3.1.

Descriptor	Definition
Carcinogenic to Humans	Strong evidence of human carcinogenicity
Likely to Be Carcinogenic to Humans	Evidence is adequate to demonstrate carcinogenic potential to humans but does not reach the weight of evidence for the "Carcinogenic to Humans" descriptor.
Suggestive Evidence of Carcinogenic Potential	The weight of evidence is suggestive of carcinogenicity; a concern for potential carcinogenic effects in humans is raised, but the data are judged insufficient for a stronger conclusion.
Inadequate Information to Assess Carcinogenic Potential	Available data are judged inadequate for applying one of the other descriptors. Additional studies generally would be expected to provide further insights.
Not Likely to Be Carcinogenic to Humans	Available data are considered robust for deciding that there is no basis for a substance to be considered a human carcinogen.

Table 6.3.1. Hazard Descriptors from the EPA's *Guidelines for Carcinogen Risk Assessment* (March 2005)

### Cancer Data for Humans

The basis for **sufficient human evidence** is an epidemiology study that clearly demonstrates a causal relationship between exposure to the substance and cancer in humans.

The data are determined to be **limited evidence in humans** if there are alternative explanations for the observed effect.

The data are considered to be **inadequate evidence in humans** if no satisfactory epidemiology studies exist.

### Cancer Data for Animals

An increase in cancer in more than one species or strain of laboratory animals or in more than one experiment is considered **sufficient evidence in animals**. Data from a single experiment can also be considered sufficient animal evidence if there is a high incidence or unusual type of tumor induced. Normally, however, a carcinogenic response in only one species, strain, or study is considered as only **limited evidence in animals**.

## 2. Quantitative Evaluation of Cancer Risk

When an agent is classified as a Human or Probable Human Carcinogen, it is then subjected to a **quantitative risk assessment**. For those designated as a Possible Human Carcinogen, the risk assessor can determine on a case-by-case basis whether a quantitative risk assessment is warranted.

The key risk assessment parameter derived from the EPA carcinogen risk assessment is the **cancer slope factor**. This is a toxicity value that quantitatively defines the relationship between dose and response. The cancer slope factor is a plausible upper-bound estimate of the probability that an individual will develop cancer if exposed to a chemical for a lifetime of 70 years. The cancer slope factor is expressed as mg/kg/day.

### Linearized Multistage Model (LMS)

Mathematical models are used to extrapolate from animal bioassay or epidemiology data to predict low-dose risk. Most assume linearity with a zero threshold dose.

 A dose-response curve is shown for a substance based on actual test results. The lowest dose that caused cancer is marked. Linear extrapolation is then used through zero threshold dose from upper confidence level of lowest dose that caused cancer.

Figure 6.3.2 *The Linearized Multistage Model is used to extrapolate cancer risk from a dose-response curve using the cancer slope factor*

(Image Source: NLM)

EPA uses the **Linearized Multistage Model (LMS)** illustrated in Figure 2 to conduct its cancer risk assessments. It yields a cancer slope factor, known as the **q1\*** (pronounced "Q1-star"), which can be used to predict cancer risk at a specific dose. It assumes linear extrapolation with a zero dose threshold from the upper confidence level of the lowest dose that produced cancer in an animal test or in a human epidemiology study.

### Other Models

Other models that have been used for cancer assessments include:

- **One-hit model**, which assumes there is a single stage for cancer and that one molecular event induces a cell transformation. This is a very conservative model.
- **Multi-hit model**, which assumes several interactions are needed before a cell can be transformed. This is one of the least conservative models.
- **Probit model**, which assumes log normal distribution (Probit) for tolerances of exposed population. This model is sometimes used, but generally considered inappropriate for assessing cancer risk.
- **Physiologically Based Pharmacokinetic (PBPK) Models**, which incorporate pharmacokinetic and mechanistic data into the extrapolation process. This model requires extensive data and is becoming commonly used.

### Application of Models to Estimate Chemical Concentrations in Drinking Water

The chemical chlordane has been found to cause a lifetime risk of one cancer death in a million persons. Different cancer risk assessment models vary in their estimates of drinking water concentrations for chlordane as illustrated in Table 6.3.2:

Model	Concentration ( $\mu\text{g/L}$ )
Probit	50
Multi-hit	2
Linearized multistage	0.07
One-hit	0.03

Table 6.3.2. Estimates of drinking water chlordane concentrations by various cancer assessment models

PBPK models are relatively new and are being employed when biological data are available. They quantitate the absorption of a foreign substance, its distribution, metabolism, tissue compartments, and elimination. Some compartments store the chemical (such as bone and adipose tissue) whereas others biotransform or eliminate it (such as liver or kidney). All these biological parameters are used to derive the target dose and comparable human doses.

## Noncarcinogenic Risk Assessment

Historically, the **Acceptable Daily Intake (ADI)** procedure has been used to calculate permissible chronic exposure levels for humans based on noncarcinogenic effects. The ADI is the amount of a chemical to which a person can be exposed each day for a long time (usually lifetime) without suffering harmful effects. It is determined by applying safety factors (to account for the uncertainty in the data) to the highest dose in human or animal studies that has been demonstrated not to cause toxicity (NOAEL).

The EPA has slightly modified the ADI approach and calculates a **Reference Dose (RfD)** as the acceptable safety level for chronic noncarcinogenic and developmental effects. Similarly, the ATSDR calculates **Minimal Risk Levels (MRLs)** for noncancer endpoints.

The **critical toxic effect** used in the calculation of an ADI, RfD, or MRL is the serious adverse effect that occurs at the lowest exposure level. It may range from lethality to minor toxic effects. It is assumed that humans are as sensitive as the animal species unless evidence indicates otherwise.

### Assessment of Chronic Exposures

In determining the ADIs, RfDs or MRLs, the **NOAEL** is divided by safety factors (uncertainty factors) in order to provide a margin of safety for allowable human exposure.

 ADI (human dose) equals NOAEL (experimental dose) divided by safety factors

When a NOAEL is not available, a **LOAEL** can be used to calculate the RfD.

An additional safety factor is included if a LOAEL is used. A Modifying Factor of 0.1–10 allows risk assessors to use scientific judgment in upgrading or downgrading the total uncertainty factor based on the reliability and quality of the data. For example, if a particularly good study is the basis for the risk assessment, a modifying factor of  $<1$  may be used. If a poor study is used, a factor of  $>1$  can be incorporated to compensate for the uncertainty associated with the quality of the study.

 Dose-response graph. Two data points are shown near the x-axis, one of which is marked the NOAEL. The threshold dose is then marked, from which a diagonal line is drawn at an approximate 45 degree angle. The LOAEL is also marked.

Figure 6.3.3. Dose-response curve for noncarcinogenic effects

(Image Source: NLM)

Figure 3 above shows a dose-response curve for noncarcinogenic effects which also identifies the NOAEL and LOAEL. Any toxic effect might be used for the NOAEL/LOAEL so long as it is the most sensitive toxic effect and considered likely to occur in humans.

The **Uncertainty Factors** or **Safety Factors** used to derive an ADI or RfD are listed in Table 6.3.3.

Situation	Uncertainty/Safety Factor
Human variability	10x
Extrapolation from animals to humans	10x

Use of less than chronic data	10x
Use of LOAEL instead of NOAEL	10x
Modifying factor	0.1—10x

Table 6.3.3. Uncertainty/Safety factors used to derive an Acceptable Daily Intake (ADI) or Reference Dose (RfD)

The modifying factor is used only in deriving EPA Reference Doses. The number of factors included in calculating the ADI or RfD depends upon the study used to provide the appropriate NOAEL or LOAEL.

The general formula for deriving the RfD is:

 RfD equals the NOAEL or LOAEL divided by the product of the uncertainty factors

The more uncertain or unreliable the data become, the higher the total uncertainty factor that is applied. An example of an RfD calculation is provided below. A subchronic animal study with a LOAEL of 50 mg/kg/day was used in the numerator. Uncertainty factors used in the denominator are 10 for human variability, 10 for an animal study, 10 for less than chronic exposure, and 10 for use of an LOAEL instead of a NOAEL.

 RfD equals 50 mg/kg/day divided by the product of the uncertainty factors, which in this case is ten times ten times ten times ten. The result is 0.005 mg/kg/day.

In addition to chronic effects, RfDs can also be derived for other long-term toxic effects, including developmental toxicity.

Traditionally, the **NOAEL method** has been used to determine the **point of departure (POD)** from animal toxicology data for use in risk assessments. However, this approach has limitations such as a strict dependence on the dose selection, dose spacing, and sample size of the study from which the critical effect has been identified. Also, using the NOAEL does not take into consideration the shape of the dose-response curve and other related information.

### Benchmark Dose Method

The **benchmark dose (BMD) method**, first proposed as an alternative in the 1980s, addresses many limitations of the NOAEL method. It is less dependent on dose selection and spacing and takes into account the shape of the dose-response curve (Figure 4). In addition, the estimation of a BMD 95% lower bound confidence limit (BMDL) results in a POD that appropriately accounts for study quality (i.e., sample size). With the availability of user-friendly BMD software programs, including the EPA's Benchmark Dose Software (BMDS), the BMD has become the method of choice for many health organizations worldwide.

 A dose-response graph is shown, with the NOAEL and LOAEL indicated. Above and to the left of the dose-response curve is another dose-response curve, in a dotted line, which represents the confidence limit on dose. The BMD and BMDL are marked as the response level as percent or standard deviation units. These values are used to extrapolate dose-response values.

Figure 6.3.4. Extrapolated values using the benchmark dose method reflect the shape of a dose-response curve  
(Image Source: EPA)

### Assessment of Noncancer Toxicity Effects

While the Agency for Toxic Substances and Disease Registry (ATSDR) does not conduct cancer risk assessments, it does derive **Minimal Risk Levels (MRLs)** for noncancer toxicity effects (such as birth defects or liver damage). The MRL is defined as an estimate of daily human exposure to a substance that is likely to be without an appreciable risk of adverse effects over a specified duration of exposure. For inhalation or oral routes, MRLs are derived for acute (14 days or less), intermediate (15–364 days), and chronic (365 days or more) durations of exposures.

The method used to derive MRLs is a modification of the EPA's RfD methodology. The primary modification is that the uncertainty factors of 10 may be lower, either 1 or 3, based on scientific judgment. These uncertainty factors are applied for human variability, interspecies variability (extrapolation from animals to humans), and use of a LOAEL instead of NOAEL. As in the case of RfDs, the product of uncertainty factors multiplied together is divided into the NOAEL or LOAEL to derive the MRL.

### Assessment of Acute or Short-Term Exposures

Risk assessments are also conducted to derive permissible exposure levels for acute or short-term exposures to chemicals. Health Advisories (HAs) are determined for chemicals in drinking water. HAs are the allowable human exposures for 1 day, 10 days, longer-term, and lifetime durations. The method used to calculate HAs is similar to that for the RfDs using uncertainty factors. Data from toxicity studies with durations of length appropriate to the HA are being developed.

## Assessment of Occupational Exposures

For **occupational exposures**, Permissible Exposure Levels (PELs), Threshold Limit Values (TLVs), and National Institute for Occupational Safety and Health (NIOSH) Recommended Exposure Levels (RELs) are developed. They represent dose levels that will not produce adverse health effects from repeated daily exposures in the workplace. The method used to derive is conceptually the same. Safety factors are used to derive the PELs, TLVs, and RELs.

## Conversion of Animal Doses to Human Dose Equivalents

Animal doses must be converted to human dose equivalents. The **human dose equivalent** is based on the assumption that different species are equally sensitive to the effects of a substance per unit of body weight or body surface area.

Historically, the FDA used a ratio of body weights of humans to animals to calculate the human dose equivalent. The EPA has used a ratio of surface areas of humans to animals to calculate the human dose equivalent. Some current approaches include multiplying the animal dose by the ratio of human to animal body weight raised to either the 2/3rd or 3/4th power (to convert from body weight to surface area). Toxicologists and risk assessors should check to make sure that the approach they are using is the one mandated or recommended by the regulatory agency of most relevance to their efforts.

## Allowable Exposures to Contamination Sources

The last step in risk assessment is to express the risk in terms of allowable exposure to a contaminated source. Risk is expressed in terms of the concentration of the substance in the environment where human contact occurs. For example, the unit for assessing risk in air is risk per -3 g)." tabindex="0">mg/m<sup>3</sup> whereas the unit for assessing risk in drinking water is risk per -3 g)." tabindex="0">mg/L.

For carcinogens, the media risk estimates are calculated by dividing cancer slope factors by 70 kg (average weight of a man) and multiplying by 20 m<sup>3</sup>/day (average inhalation rate of an adult) or 2 liters/day (average water consumption rate of an adult).

### Knowledge Check

The procedures used to extrapolate from high to low doses primarily depend upon the:

- Threshold dose of the substance
- Rate of lethality in laboratory animals
- Carcinogenicity of the substance

#### Answer

Genotoxic carcinogenicity of the substance - **This is the correct answer.**

The procedure for extrapolation from high to low doses depend on whether or not the effects are carcinogenic. Carcinogenic effects are not considered to have a threshold dose and mathematical models are used to estimate the risk of carcinogenicity at very low doses. Noncarcinogenic effects are considered to have threshold doses and the margin of safety (MOS) is calculated.

According to EPA, a substance is classified as likely to be carcinogenic to humans when:

- There is strong evidence of human carcinogenicity
- Evidence is adequate to demonstrate potential carcinogenicity to humans, but not strongly enough to definitively classify as carcinogenic
- The weight of evidence suggests human carcinogenicity, but the data are determined not to be sufficient for a stronger conclusion
- Robust data lead to the conclusion that a substance is clearly carcinogenic to humans

#### Answer

Evidence is adequate to demonstrate potential carcinogenicity to humans, but not strongly enough to definitively classify as carcinogenic - **This is the correct answer.**

A substance is classified as likely to be carcinogenic to humans when evidence is adequate to demonstrate carcinogenic potential to humans but does not reach the weight of evidence for the descriptor Carcinogenic to Humans.

The primary cancer risk assessment model used by the EPA is known as the:

- Linearized Multistage Model (LMS)
- Probit Model
- Physiologically Based Pharmacokinetic Model (PB-PK)

**Answer**

Linearized Multistage Model (LMS) - **This is the correct answer.**

EPA uses the Linearized Multistage Model (LMS) to conduct its cancer risk assessments, producing the  $q1^*$  that is used to predict cancer risk at a specific dose.

The Acceptable Daily Intake (ADI) is calculated by:

- Dividing the NOAEL by safety factors
- Dividing the NOAEL by the LOAEL
- Multiplying the RfD by a modifying factor
- Linear extrapolation from the LOAEL to the zero intercept

**Answer**

Dividing the NOAEL by safety factors - **This is the correct answer.**

The ADI is calculated by dividing the NOAEL by safety factors.

Animal doses must be converted to human dose equivalents for risk assessment. When doing this, toxicologists and risk assessors must:

- Multiply the animal dose by the ratio of human to animal body weight raised to the  $\frac{2}{3}$  power
- Ensure they use the conversion method mandated or recommended by the regulatory agency most relevant to their efforts
- Multiply the animal dose by the ratio of human to animal body weight raised to the  $\frac{3}{4}$  power

**Answer**

Ensure they use the conversion method mandated or recommended by the regulatory agency most relevant to their efforts - **This is the correct answer.**

Toxicologists and risk assessors should check to ensure they use the approach mandated or recommended by the regulatory agency most relevant to their efforts.

Minimal Risk Levels (MRLs) are derived:

- Similarly to deriving the RfD, but with a potentially lower uncertainty factor
- By multiplying the cancer slope factor by the lowest exposure dose
- By multiplying the LOAEL by safety factors

**Answer**

Similarly to deriving the RfD, but with a potentially lower uncertainty factor - **This is the correct answer.**

The MRL is calculated much like the RfD, except that the uncertainty factors of 10 may be lower (1 or 3), based on scientific judgment.

This page titled [6.3: Dose-Response Assessment](#) is shared under a [CC BY-NC 4.0](#) license and was authored, remixed, and/or curated by [ToxMSDT Online component](#) via [source content](#) that was edited to the style and standards of the LibreTexts platform.

## 6.4: Exposure Assessment

# Exposure Assessment

### No Exposure = No Risk

An expression used in toxicology is "no exposure = no risk." Exposure assessment is a key step in the risk assessment process because without an exposure, even the most toxic chemical does not present a threat. Our understanding of potential exposures to chemicals has grown significantly since approximately 1980. For example, research has identified previously "missing" sources and pathways of potential indoor air exposures such as chemicals from consumer products or elsewhere that end up in household dust.

Environmental contaminants are analyzed according to their releases, movement and fate in the environment, and the exposed populations. Consumer products and pharmaceuticals are analyzed in terms of reasonably foreseeable potential exposures.

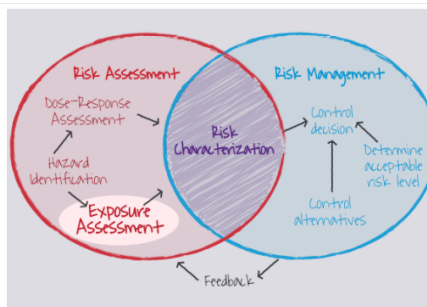

Figure 6.4.1 Exposure assessment as a component of risk assessment (Image Source: ORAU, ©)

## Sources of Exposure

Everyday life can involve a person being exposed to mixtures of hundreds of chemicals. Examples of documented non-occupational sources include:

- Consumer products (perhaps 20 or more during a day).
- Clothing.
- Residential and other water.
- Indoor and outdoor air.
- Food and food packaging.
- Beverages.
- Toys.
- Furniture.
- Carpeting, paint, and other building materials.
- Tobacco smoke.
- Household dust containing chemicals from consumer products.
- Outdoor soil and soil tracked indoors.

Figure 6.4.2 highlights potential exposures from a chemical used in furniture fabric.



Figure 6.4.2 Exposure to a chemical used in furniture textiles

(Image Source: Adapted from U.S. National Academy Press [publication](#) and iStock Photos, ©)

Figure 6.4.3 illustrates some of the types of possible consumer exposures from a hand dishwashing product.





Figure 6.4.3. The many uses and types of exposures for a dishwashing product  
(Image Source: Adapted from iStock Photos, ©)

Other residential sources of chemicals can come from household air and water. For example, chemicals in air can deposit on, absorb into, or **adsorb** (Adsorption occurs when molecules of a gas, liquid, or dissolved solid adhere to a surface and create a thin film around it) onto household materials (such as carpets and foods and food packaging), which can lead to dermal and oral exposures. When chemicals are confined to indoor spaces and not diluted in outdoor air, there can be large differences in indoor versus outdoor levels of a chemical.

Figure 6.4.4 illustrates some other residential exposures to chemicals via water.

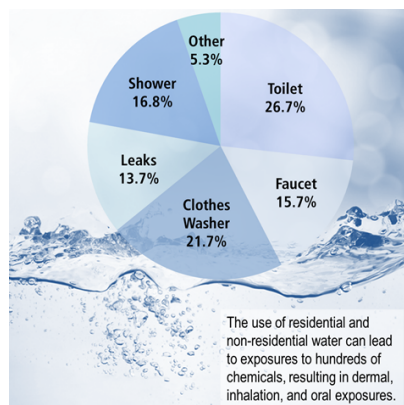

Figure 6.4.4. Water is a household source of chemicals  
(Data Source: American Water Works Association Research Foundation, "Residential End Users of Water," 1999.  
Learn more at [EPA WaterSense](#).  
Image Source: Adapted from iStock Photos, ©)

## Exposure Pathways

The route a substance takes from its source (where it began) to its endpoint (where it ends), and how people can come into contact with (or be exposed to) it is defined as an **exposure pathway**.

An exposure pathway has five parts:

1. A **source of exposure**, such as using a consumer product for a household task or a chemical spilled from a truck onto a highway.
2. An **environmental media and transport mechanism**, such as movement through the indoor or outdoor air or groundwater.
3. A **point of exposure**, such as a person's house or a private well.
4. A **route of exposure** — eating, drinking, breathing, or touching.
5. A **receptor population** — a person or group of people potentially or actually exposed.

When all five parts are present, the exposure pathway is termed a **completed exposure pathway**.

(Source: [ATSDR Glossary](#))

## Process of Exposure Assessment

Exposure assessment is a three-step process:



The main variables in the exposure assessment are:

- Exposed populations.
- Types of substances.
- Single substance or mixture of substances.
- Frequency and duration of exposure.
- Pathways and types of exposure.

All possible types of reasonably foreseeable exposures are considered in order to assess the toxicity and risk that might occur.



## Considerations for Environmental Exposure

For an environmental exposure, the risk assessor would look at the physical environment and the potentially exposed populations. The physical environment may include considerations about climate, vegetation, soil type, groundwater and surface water. Populations that may be exposed as the result of chemicals that migrate from the site of pollution are also considered.

Subpopulations may be at greater risk due to a higher level of exposure or because they have increased sensitivity. Examples include infants, the elderly, pregnant women, and those with chronic illness.

Pollutants may be transported away from the source and may be physically, chemically, or biologically transformed. They may also accumulate in various materials. Assessment of the chemical fate requires knowledge of many factors, including:

- Organic carbon and water partitioning at equilibrium ( $K_{oc}$ ).
- Chemical partitioning between soil and water ( $K_d$ ).
- Partitioning between air and water (Henry's Law Constant).
- Solubility constants.
- Vapor pressures.
- Partitioning between water and octanol ( $K_{ow}$ ).
- Bioconcentration factors.

These factors are integrated with the data on sources, releases, and routes of the pollutants to determine the exposure pathways of importance, such as groundwater, surface water, air, soil, food, and/or breastmilk.

## Use of Exposure Models

Because actual measurements of exposures are often not available, exposure models may be used. For example:

- In air quality studies, chemical emission and air dispersion models are used to predict the air concentrations to downwind residents.
- Residential wells downstream from a site may not currently show signs of contamination. They may become contaminated in the future as chemicals in the groundwater migrate to the well site.

In these situations, groundwater transport models can be used to estimate when chemicals of potential concern will reach the wells.

## Information Sources on Chemical Exposures and Health

The future of exposure assessment promises to involve more information and more approaches.

Find out more information about:

- [Chemicals in personal care products](#) from the National Institute of Environmental Health Sciences (NIEHS).
- [Data connections between the environment and diseases](#) listed in the Comparative Toxicogenomics Database (CTD).
- [Chemical safety tools and databases](#) from the Environmental Protection Agency (EPA).
- [Health effects of chemical exposures fact sheet](#) and [Web site information](#) from the Agency for Toxic Substances & Disease Registry (ATSDR).
- Publications like "[Exploring Global Exposure Factors Resources for Use in Consumer Exposure Assessments](#)."

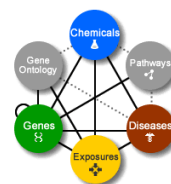

Figure 6.4.5 Topics covered by CTD  
(Image Source: CTD)

## Considerations When Reading About a New Exposure Study

When reading about a new exposure study, there are several questions you can consider to critically evaluate studies about everyday chemical exposures ([source](#)):

1. Is the study published in a peer-reviewed journal?
2. Are there other publications that lend or do not lend support to the current research, or is this study possibly the first of its kind that suggests an emerging issue for regulators, chemical companies, consumer product manufacturers, and others to consider?
3. In addition to scientific journal publications, is there information available from government or other Web sites that provides perspectives about the exposures and potential risks?
4. How was the study conducted? For example, is it a preliminary or "pilot" study involving a small number of people who were studied, and did the participants represent a narrow or broad, wide range of the types of potentially affected consumers?
5. Did the study use household products/materials or food to which some consumers are likely to be exposed? If yes, are there geographical or other limitations that should be noted by the authors such as the products or food being likely to be sold only in one country or region of the world?
6. Did the study try to approach "reasonably foreseeable" consumer exposure conditions?
7. Is there a known or reasonably foreseeable association between these types of exposures and human adverse effects?

This page titled [6.4: Exposure Assessment](#) is shared under a [CC BY-NC 4.0](#) license and was authored, remixed, and/or curated by [ToxMSDT Online component](#) via [source content](#) that was edited to the style and standards of the LibreTexts platform.

## 6.5: Risk Characterization

# Risk Characterization

Approaches to risk characterization continue to evolve. The final stage in the risk assessment process involves predicting the frequency and severity of effects in exposed populations. The conclusions reached from the stages of hazard identification and exposure assessment are integrated to determine the probability of effects likely to occur in humans exposed under similar conditions.

Because most risk assessments include major uncertainties, it is important to describe biological and statistical uncertainties in risk characterization. The assessment should identify which components of the risk assessment process involve the greatest degree of uncertainty.

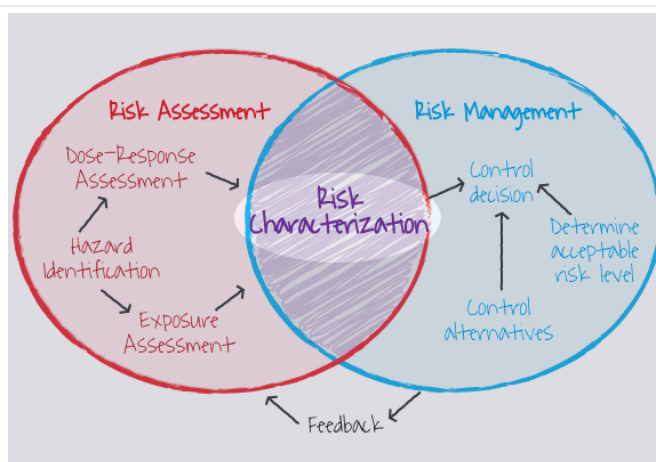

Figure 1. Risk characterization is the final phase of risk assessment (Image Source: ORAU, ©)

## For Carcinogenic Risks

Potential human carcinogenic risks associated with chemical exposure are expressed in terms of an increased probability of developing cancer during a person's lifetime. For example, a  $10^{-6}$  increased cancer risk represents an increased lifetime risk of 1 in 1,000,000 for developing cancer. For carcinogenicity, the probability of an individual developing cancer over a lifetime has historically been estimated by multiplying the cancer slope factor ( $mg/kg/day$ ) for the substance by the chronic (*70-year average*) daily intake ( $mg/kg/day$ ).

## For Noncarcinogenic Effects

For noncarcinogenic effects, the exposure level has historically been compared with an ADI, RfD, or MRL derived for similar exposure periods. Three exposure durations are considered: acute, intermediate, or chronic. For humans:

- **Acute effects** — arise within days to a few weeks.
- **Intermediate effects** — evident in weeks to a year.
- **Chronic effects** — manifest in a year or more.

## For Multiple Exposures

In some complex risk assessments, such as for hazardous waste sites, the risk characterization must consider multiple chemical exposures and [multiple exposure pathways](#) (described in Exposure Assessments).

Simultaneous exposures to several chemicals, each at a subthreshold level, can often cause adverse effects by "adding" the multiple exposures together, called **dose additivity**.

The assumption of dose additivity is most acceptable when substances induce the same toxic effect by the same mechanism. When available, information on mechanisms of action and chemical interactions are considered and are useful in deriving more scientific risk assessments.

Individuals are often exposed to a substance by more than one exposure pathway (*for example, drinking contaminated water and inhaling contaminated dust*).

## Knowledge Check

1) A major component of exposure assessment involves:

- a) Identifying the exposure pathways
- b) Measuring the amount of a substance that is metabolized in the body
- c) Determining the amount of exposure that must be reduced to comply with the acceptable risk level

### Answer

Identifying the exposure pathways - **This is the correct answer.**

Exposure pathways are key to exposure assessment because they identify the route a substance takes from its source to its end point, as well as how people can be exposed to the substance.

2) The movement of substances in environmental media is primarily predicted by:

- a) Tagging substances with radioactive tracers and measuring radioactivity at various times and locations within the environmental media
- b) Using exposure models to derive scientific estimates
- c) Performing actual measurements of exposure pathways

### Answer

Using exposure models to derive scientific estimates - **This is the correct answer.**

Since actual measurements of exposures are often unavailable, exposure models may be used.

3) Which of the following is not true about risk characterization?

- a) It involves predicting the frequency and severity of effects in exposed populations
- b) It determines the amount of exposure that must be reduced to comply with the acceptable risk level
- c) It integrates conclusions reached in hazard identification and exposure assessment
- d) It yields probabilities of effects likely to occur in humans exposed under similar conditions

### Answer

It determines the amount of exposure that must be reduced to comply with the acceptable risk level - **This is the correct answer.**

Risk characterization involves predicting the frequency and severity of effects in exposed populations. It integrates conclusions reached in hazard identification and exposure to yield probabilities of effects likely to occur in humans exposed under similar conditions.

4) An increased cancer risk of  $2.0 \times 10^{-6}$  (^ indicates to the -6 power) means that:

- a) It is likely that two people out of one million will develop the specific type of cancer in their lifetime due to exposure to the chemical
- b) The xenobiotic for which the cancer risk assessment was performed is likely to cause cancer in two people on a yearly basis
- c) It is likely that two people out of one thousand will develop the specific type of cancer in their lifetime due to exposure to the chemical
- d) It is probable that two million people will develop cancer if they are continuously exposed to the chemical for life

### Answer

It is likely that two people out of one million will develop the specific type of cancer in their lifetime due to exposure to the chemical - **This is the correct answer.**

An increased cancer risk of 2 times  $10^{-6}$  means two in a million people will likely develop the specific type of cancer in their lifetime due to exposure to the chemical.

## CHAPTER OVERVIEW

### Section 7: Exposure Standards and Guidelines

## Learning Objectives

After completing this lesson, you will be able to:

- Explain the difference between exposure standards and guidelines.
- Identify approaches to regulating consumer products and drug safety.
- Describe standards and guidelines for environmental and occupational exposure.

## In this section...

Topics include:

- [7.1: Exposure Standards and Guidelines](#)
- [7.2: Regulation of Consumer Products and Drug Safety](#)
- [7.3: Environmental Exposure Standards/Guidelines](#)
- [7.4: Occupational \(Workplace\) Exposure Standards/Guidelines/Approaches](#)

## What We've Covered

This section made the following main points:

- **Standards** are legally acceptable exposure levels or controls set by Congressional or Executive mandate.
- **Guidelines** are recommended maximum exposure levels and are voluntary and not legally enforceable.
- Consumer products
  - The U.S. Consumer Product Safety Commission (CPSC) protects the public from unreasonable risks of harm connected with consumer products.
  - The CPSC establishes consumer exposure standards for hazardous substances and articles.
  - The CPSC requires warning labels on containers of household products that are toxic, corrosive, irritating, or sensitizing.
- Drugs
  - FDA approval is required before pharmaceuticals can be marketed.
  - Animal studies and human clinical trials are required to determine toxic dose levels.
  - The New Drug Application (NDA) contains guidance for drug usage and warnings regarding side effects and interactions.
  - Information about a drug's harmful side effects must be provided through labeling and package inserts, publication in the Physicians' Desk Reference (PDR), and direct-to-consumer marketing.
- Food additives
  - The FDA is responsible for approving food additives.
  - **Direct additives** are intentionally added to foods for functional purposes and include processing aids, flavors, appearance agents, and nutritional supplements.
  - **Indirect additives** are not intentionally added to foods and are not natural constituents of foods, but become constituents during production, processing, packaging, and storage.
  - FDA scientists must review new direct food additives before they can be used in foods.
  - Generally Recognized as Safe (GRAS) additives are generally accepted as safe for an intended use and can be introduced into the food supply without prior FDA approval.
- Environment
  - The EPA establishes exposure standards for pesticides, water pollutants, air pollutants, and hazardous wastes.
  - Pesticides must be registered with EPA after undergoing extensive analyses.
  - The EPA prepares health advisories (HAs) as voluntary exposure guidelines for drinking water contamination.

- Ambient water quality criteria help control pollution sources at the point of release into the environment.
- National Ambient Air Quality Standards (NAAQS) protect public health and welfare from air pollution.
- Hazardous wastes are regulated under the Resource Conservation and Recovery Act (RCRA) and Superfund.
- RCRA regulates hazardous and non-hazardous solid waste.
- Occupational Safety
  - The Occupational Safety and Health Administration (OSHA) establishes legal standards for worker exposure in the United States.
  - Permissible Exposure Limits (PELs) list air concentration limits for chemicals, but not skin absorption or sensitization.
  - Short Term Exposure Limit (STELs) PELs are concentration limits of substances in the air that workers may be exposed to for 15 minutes without adverse effects.
  - Ceiling limits are concentration limits for airborne substances that must not be exceeded.
  - Immediately dangerous to life or health (IDLH) designates an airborne exposure or atmosphere that could lead to death or immediate or delayed permanent adverse health effects.
  - Control banding (CB) determines a control measure based on a band of hazards, such as skin irritation or carcinogenic potential, and exposures.

---

This page titled [Section 7: Exposure Standards and Guidelines](#) is shared under a [CC BY-NC 4.0](#) license and was authored, remixed, and/or curated by [ToxMSDT Online component](#) via [source content](#) that was edited to the style and standards of the LibreTexts platform.

## 7.1: Exposure Standards and Guidelines

# Exposure Standards and Guidelines

Exposure standards and guidelines are developed by governments to protect the public from harmful substances and activities that can cause serious health problems. This section describes standards and guidelines relating to protection from the toxic effects of chemicals only.

Exposure standards and guidelines are determined by risk management decisions. Risk assessments provide regulatory agencies with estimates of numbers of persons potentially harmed under specific exposure conditions. Regulatory agencies then propose exposure standards and guidelines designed to protect the public from "unacceptable risk" levels.

Exposure standards and guidelines usually provide numerical exposure levels for various media (such as food, consumer products, water, and air) that should not be exceeded. Alternatively, these standards may be preventive measures to reduce exposure (such as labeling, special ventilation, protective clothing and equipment, and medical monitoring).



Figure 7.1.1 Standards and guidelines protect the public from harmful substances

(Image Source: iStock Photos, ©)

## Standards and Guidelines

More specifically, standards and guidelines for chemical exposure levels consist of the following:

- **Standards** — legally acceptable exposure levels or controls issued as the result of Congressional or Executive mandate. They result from formal rulemaking and are legally enforceable. Violators are subject to punishment, including fines and imprisonment.
- **Guidelines** — recommended maximum exposure levels which are voluntary and not legally enforceable. Guidelines may be developed by regulatory and non-regulatory agencies, or by some professional societies.

Federal and state regulatory agencies have the authority to issue permissible exposure standards and guidelines in the following categories:

- Consumer Product Exposure Standards and Guidelines
- Environmental Exposure Standards and Guidelines
- Occupational Exposure Standards and Guidelines

### Knowledge Check

#### 1) Exposure standards are:

Developed by chemical manufacturers

Recommended maximum exposure levels which are voluntary and not legally enforceable

Legally enforceable acceptable exposure levels or controls

#### Answer

Legally enforceable acceptable exposure levels or controls - **This is the correct answer.**

Exposure standards are legally enforceable acceptable exposure levels or controls resulting from Congressional or Executive mandate.

## 2) Exposure guidelines are:

Developed by chemical manufacturers

Recommended maximum exposure levels which are voluntary and not legally enforceable

Legally enforceable acceptable exposure levels or controls

### Answer

Recommended maximum exposure levels which are voluntary and not legally enforceable - **This is the correct answer.**

Exposure guidelines are recommended maximum exposure levels that are voluntary and not legally enforceable.

---

This page titled [7.1: Exposure Standards and Guidelines](#) is shared under a [CC BY-NC 4.0](#) license and was authored, remixed, and/or curated by [ToxMSDT Online component](#) via [source content](#) that was edited to the style and standards of the LibreTexts platform.

## 7.2: Regulation of Consumer Products and Drug Safety

### Regulation of Consumer Products and Drug Safety

Consumer products are often called household products. It is important to know what a category of product is called in the area of the world of interest.

For example, in the United States, cosmetic products are defined by the [FDA](#) as those products "intended to be applied to the human body for cleansing, beautifying, promoting attractiveness, or altering the appearance without affecting the body's structure or functions." While cosmetics are often thought of as being make-up products such as eye-liner, lipstick, or nail polish, the FDA definition includes skin-care creams, lotions, powders, and perfumes. However, soap products are excluded from FDA's definition of cosmetics.

In comparison, in the European Union (EU), the European Commission's definition of cosmetic products includes soap, shampoo, deodorant, toothpaste, perfumes, and makeup.

It is also important to keep in mind that some products are known by different names. For example, what is known as a cloth or disposable diaper in the United States is called a nappy in several other countries.

Figure 7.2.1. Shopping for c  
(Image Source: iStock Phot

### U.S. Consumer Product Safety Commission (CPSC)

The U.S. [Consumer Product Safety Commission](#) (CPSC) is charged with "protecting the public from unreasonable risks of injury or death associated with the use of the consumer products" under its jurisdiction such as toys, cribs, power tools, cigarette lighters, and household chemical-containing products. The CPSC considers if a product could pose a fire, electrical, chemical, or mechanical (such as choking) hazard. CPSC's work, including research, product recalls, education, and administration of regulations, laws, and standards, has resulted in a decline in the rate of deaths and injuries associated with consumer products over the past several decades.

Consumer exposure standards are developed for hazardous substances and articles by the CPSC. The authority under the [Federal Hazardous Substance Act](#) (FHSA) pertains to substances other than pesticides, drugs, foods, cosmetics, fuels, and radioactive materials. The CPSC-required warning labels on containers of household products that are toxic, corrosive, irritants, or sensitizers help consumers to safely store and use those products and to give them information about immediate first aid steps to take if an accident happens. Highly toxic substances are labeled with DANGER; less toxic substances are labeled with WARNING or CAUTION.

Figure 7.2.2. CPSC danger label for a gas-powered generator  
(Image Source: CPSC)

The CPSC's basis for a determination of highly toxic has been death in laboratory rats at an oral dose of 50 mgs, or an inhaled dose in rats of 200 ppm for one hour, or a 24-hour dermal dose in rabbits of 200 mg/kg. A substance is corrosive if it causes visible destruction or irreversible damage to the skin or eye. If it causes damage that is reversible within 24 hours, it is designated an irritant. An immune response from a standard sensitization test in animals is sufficient for designating the substance a sensitizer.

CPSC is a member of the U.S. Interagency Coordinating Committee on the Validation of Alternative Methods ([ICCVAM](#)), a permanent committee of the National Institutes of Environmental Health Science (NIEHS) under the National Toxicology Program Interagency Center for the Evaluation of Alternative Toxicological Methods ([NICEATM](#)). ICCVAM was created "to establish, wherever feasible, guidelines, recommendations, and regulations that promote the regulatory acceptance of new or revised scientifically valid toxicological tests that protect human and animal health and the environment while reducing, refining, or replacing animal tests and ensuring human safety and product effectiveness."

### European Commission General Product Safety Directive (GPSD)

In the EU, the European Commission's [General Product Safety Directive](#) (GPSD) requires producers and distributors to place only safe consumer products on the market and to take all necessary measures to prevent risks to consumers. The GPSD excludes certain product categories covered by specific European safety regulations. It provides an alert system (Rapid Alert System for non-food dangerous products – "RAPEX") between the Commission and EU Member States, Norway, Iceland and Liechtenstein.

### U.S. Food and Drug Administration (FDA)

The FDA oversees food safety, tobacco products, dietary supplements, prescription and non-prescription drugs, vaccines, blood products, medical devices, electromagnetic radiation emitting devices, cosmetics, animal foods, and veterinary products.

### Drugs

Manufacturers of new pharmaceuticals must obtain formal FDA approval before their products can be marketed. Drugs intended for use in humans must undergo animal studies and human clinical trials to determine toxic dose levels prior to filing a [New Drug Application](#) (NDA).

#### Did you know?

During the late 1950s the drug [Thalidomide](#) was used to control nausea and vomiting in pregnancy in Canada, Europe, Australia, and parts of Asia. After the drug came on the market, reports appeared of children born with missing limbs, with upper limbs usually more affected than lower limbs. In addition to damage to arms and legs, faces, eyes, ears, and genitalia, internal organs including the heart, kidney, and gastrointestinal tract were damaged.

Thalidomide did not reach the US market due to the efforts of an astute FDA drug reviewer, Dr. Frances Oldham Kelsey, who insisted that thalidomide be fully tested before approval. In response to the episode, the Kefauver Harris Amendment to the Federal Food, Drug, and Cosmetic Act became law in 1962. The amendment requires drug manufacturers to give proof of the effectiveness and safety of a drug before it can be approved.

Thalidomide continues to be prescribed under strict supervision as a treatment for multiple myeloma, leprosy, certain complications of human immunodeficiency virus (HIV), and autoimmune disorders. In the 2000s, children with thalidomide-related birth defects were noted in Brazil due to the use of thalidomide to treat leprosy. Pregnant women were being exposed when family members took the drug.

Figure 7.2.3 Thalidomide  
(Image Source: [NLM Cit](#)



An NDA covers all aspects of a drug's effectiveness and safety, including:

- Pharmacokinetics and pharmacological effects.
- Metabolism and postulated mechanism of action.
- Associated risks of the drug.
- Intended uses and therapeutic efficacy.
- Risk:benefit relationship.
- Basis for package inserts supplied to physicians.

The FDA does not issue exposure standards for drugs. Instead, it approves an NDA that contains guidance for usage and warnings concerning potential side effects of a drug. The manufacturer is required to provide this information to physicians prescribing the drug as well as to others that may purchase or use the drug. Information on a drug's harmful side effects is provided in three main ways:

1. Labeling and package inserts that accompany a drug and explain approved uses, recommended dosages, and effects of overexposure.
2. Publication of information in the Physicians' Desk Reference (PDR) and other publically available databases.
3. Direct-to-consumer advertisements.

Figure 7.2.4 Drugs must i  
(Image Source: iStock Pho

The package insert labels and the PDR contain the following information:

- Description
- Clinical pharmacology
- Indications and usage
- Contraindications
- Warnings
- Precautions
- Adverse reactions
- Interactions
- Overdosage
- Available forms
- Dosage and administration

Figure 7.2.5. Sample package insert for a fictional prescription drug  
(Image Source: [FDA](#))

## Food Additives

The FDA is responsible for the approval of food additives. Standards are different depending on whether they are direct food additives or indirect food additives.

**Direct food additives** are intentionally added to foods for functional purposes. Examples of direct food additives include:

- Processing aids
- Texturing agents
- Preservatives
- Flavoring and appearance agents
- Nutritional supplements

Approval usually designates the maximum allowable concentrations in a food product.

Figure 7.2.6 A worker in a food production plant adds a mix of dry flavoring and processing agents to meat  
(Image Source: iStock Photos, ©)

**Indirect food additives** are not intentionally added to foods and they are not natural constituents of foods. They become a constituent of the food product from environmental contamination during production, processing, packaging, and storage. Examples of indirect food additives are:

- Antibiotics administered to cattle.
- Pesticide residues remaining after production or processing of foods.
- Chemicals that migrate from packaging materials into foods.

Exposure standards indicate the maximum allowable concentration of these substances in food.

New direct food additives must undergo stringent review by FDA scientists before they can be approved for use in foods. The manufacturer of a direct food additive must provide evidence of the safety of the food additive in accordance with specified uses. The safety evaluation is conducted by the toxicity testing and risk assessment procedures previously discussed with derivation of the ADI. In contrast to pharmaceutical testing, virtually all toxicity evaluations are conducted with experimental laboratory animals.

FDA approval of all new food additives has been required since the Food, Drug and Cosmetic Act (FDCA) was amended in 1958. At that time, all existing food additives were [Generally Recognized as Safe](#) (GRAS) and no exposure standard was developed. Many of GRAS substances have since been reevaluated and maximum acceptable levels have been established. However, under the law, a substance may be determined to be GRAS for an intended use and introduced into the food supply as such without prior approval by FDA. FDA maintains a searchable database of [GRAS substances](#).

Figure 7.2.7. Select Committee on GRAS Substances searchable database

The FDA reevaluation of GRAS substances requires that specific toxicity tests be conducted based on the level of the GRAS substance in a food product. For example, the lowest level of concern is for an additive used at 0.05 ppm in the food product. Only short-term tests (a few weeks) are required for those compounds. In contrast, a food additive used at levels higher than 1.0 ppm must be tested for carcinogenicity, chronic toxicity, reproductive toxicity, developmental toxicity, and mutagenicity.

The 1958 amendment to the Food, Drug and Cosmetic Act law is known as the Delaney Clause. This clause prohibited the addition of any substance to food that has been shown to induce cancer in man or animals. The implication was that any positive result in an animal test, regardless of dose level or mechanism, is sufficient to prohibit use of the substance. In this case, the allowable exposure level is zero. In 1958, chemical levels could only be measured in parts per thousand whereas analytical methods today allow some chemical levels to be measured down to parts per trillion or quintillion. Such levels might represent negligible cancer risks and Congress has repeatedly amended the Delaney Clause to create more and more exceptions. In 1996, the Delaney Clause was repealed, and the "zero-risk" standard was changed to one of "reasonable certainty."

## Food Safety in the European Union (EU)

## General Food Law

The basic principles for the EU's food safety policy are defined in the EU's General Food Law ([Regulation \(EC\) No 178/2002](#)), adopted in 2002. This regulation:

- Lays down general principles, requirements and procedures that underpin decision making in matters of food and feed safety, covering all stages of food and feed production and distribution.
- Sets up an independent agency responsible for scientific advice and support, the **European Food Safety Authority (EFSA)** - see below for more information.
- Creates the main procedures and tools for the management of emergencies and crises as well as the [Rapid Alert System for Food and Feed \(RASFF\)](#).

Figure 8. Flags of the European Union and various member nations  
(Image Source: iStock Photos, ©)

## European Food Safety Authority (EFSA)

The [European Food Safety Authority \(EFSA\)](#) was set up in 2002 and is based in Parma, in Italy. It carries out risk assessments before certain foods are allowed to be sold in the EU. The agency was legally established by the EU under the [General Food Law - Regulation 178/2002](#). The General Food Law created a European food safety system in which responsibility for risk assessment (science) and for risk management (policy) are kept separate. [EFSA](#) is responsible for the former area, and also has a duty to communicate its scientific findings to the public.

EFSA provides scientific advice to the European Commission and EU countries, to help them take effective decisions to protect consumers. It also plays an essential role in helping the EU respond swiftly to food safety crises. EFSA's remit covers:

- Food and feed safety
- Nutrition
- Animal health and welfare
- Plant protection
- Plant health

It also considers, through environmental risk assessments, the possible impact of the food chain on the biodiversity of plant and animal habitats (discover [EFSA topics](#), [EFSA scientific work areas](#), and [application resources by food sector area](#)). EFSA publishes all its scientific outputs, including its scientific opinions, in the [EFSA Journal](#). It also issues a range of [supporting publications](#). Most of [EFSA's work](#) is undertaken in response to requests for scientific advice from the European Commission, the European Parliament and EU Member States. EFSA also carry out scientific work on own initiative, in particular to examine emerging issues and new hazards and to update our assessment methods and approaches. This is known as "self-tasking." EFSA's quality management system (QMS) has been awarded an ISO 9001:2015 certificate, the international standard for quality management.

EFSA's Scientific Panels of experts are responsible for the bulk of EFSA's scientific assessment work. Each of the 10 Panels is dedicated to a different area of the food and feed chain. The Scientific Committee has the task of supporting the work of the Panels on cross-cutting scientific issues. It focuses on developing harmonized risk assessment methodologies in fields where EU-wide approaches are not yet defined.

EFSA staff support the Scientific Panels and Scientific Committee in carrying out most of the Authority's [scientific work](#). The membership of EFSA's Scientific Committee and Panels is renewed every three years (see also [Working practices](#) and [EFSA Strategy 2020 - Trusted science for safe food](#)).

The EU General Food Law deals with a wide range of issues related to food in general and food safety in particular, including food information and animal welfare. It covers all parts of the food chain from animal feed and food production to processing, storage, transport, import and export, as well as retail sales. It also establishes the principles for risk analysis. These stipulate how, when, and by whom scientific and technical assessments should be carried out in order to ensure that humans, animals, and the environment are properly protected.

## EU Food Safety Policy

The EU's food safety policy covers food from farm to fork. The EU food policy comprises:

- Comprehensive legislation on food and animal feed safety and food hygiene.
- Sound scientific advice on which to base decisions.
- Enforcement and checks.

Where specific consumer protection is justified, there may be special rules on:

- Use of pesticides, food supplements, colorings, antibiotics, or hormones.
- Food additives, such as preservatives and flavorings
- Substances in contact with foodstuffs, for example, plastic packaging.
- Labeling of ingredients that may cause allergies.
- Health claims such as "low-fat" or "high-fiber."

The EU's [Rapid Alert System for Food and Feed \(RASFF\)](#) was launched in 1979 and allows information on food and feed to be shared quickly and efficiently between all the relevant bodies at national and EU-level. In a similar vein, the [EU Notification System for Plant Health Interceptions \(EUROPHYT\)](#) is the EU's notification and rapid alert system for plant products entering and being traded within the EU. It helps to prevent the introduction and spread of plant disease and plant pests.

The EU's [Trade Control and Expert System \(TRACES\)](#) is a system for tracking live animals and food and feed of animal origin as they enter the EU and are traded within the EU. It links veterinary authorities across and outside the EU, and enables veterinary services and businesses to react swiftly when a health threat is discovered.

## Regulatory Science in the European Union

The following tables describe regulatory science in the EU, including links to the relevant agencies. The list is a work in progress.

Regulatory Science (the table below is best viewed on a computer browser)

--

Area	Regulatory Science (click links for more information)
Animal health and welfare	<a href="#">European Food Safety Authority</a>
Animal feed	<a href="#">European Food Safety Authority</a>
Biological hazards	<a href="#">European Food Safety Authority</a>
Biocidal Active Substances	<a href="#">European Chemicals Agency</a>
Biocidal Products	<a href="#">European Chemicals Agency</a>
Botanicals	<a href="#">European Food Safety Authority</a>
Consumer products	European Commission <a href="#">General Product Safety Directive (GPSD)</a>
Communicable diseases	<a href="#">European Centre for Disease Prevention and Control</a>
Food additives	<a href="#">European Food Safety Authority</a>
Food ingredients	<a href="#">European Food Safety Authority</a>
Food Colors	<a href="#">European Food Safety Authority</a>
Food Contact Materials	<a href="#">European Food Safety Authority</a>
Food enzymes	<a href="#">European Food Safety Authority</a>
Food Supplements	<a href="#">European Food Safety Authority</a>
Non-plastic food contact materials	<a href="#">European Food Safety Authority</a>
Plastics and plastic recycling	<a href="#">European Food Safety Authority</a>
Smoke Flavorings	<a href="#">European Food Safety Authority</a>
Sweeteners	<a href="#">European Food Safety Authority</a>
Food packaging	<a href="#">European Food Safety Authority</a>
GMO	<a href="#">European Food Safety Authority</a>
Plant Health	<a href="#">European Food Safety Authority</a>
Pesticides	<a href="#">European Food Safety Authority</a>
Nutrition	<a href="#">European Food Safety Authority</a>
Nutrient sources	<a href="#">European Food Safety Authority</a>
Vitamins and minerals	<a href="#">European Food Safety Authority</a>

List above shows regulatory authorities over specific areas of science in the European Union

Regulatory Authorities (the table below is best viewed on a computer browser)

Agency (click links for more information)	Area of Authority
<a href="#">European Food Safety Authority (EFSA)</a>	<ul style="list-style-type: none"> <li>• Animal health and welfare</li> <li>• Biological hazards</li> <li>• Chemical contaminants</li> <li>• Cross-cutting science</li> <li>• Food ingredients and food packaging</li> <li>• GMO</li> <li>• Nutrition</li> <li>• Pesticides</li> <li>• Plant health</li> <li>• Chemicals</li> <li>• Biocides</li> </ul>
<a href="#">European Chemicals Agency (ECHA)</a>	Scientific evaluation, supervision and safety monitoring of medicines
<a href="#">European Medicines Agency (EMA)</a>	Communicable diseases
<a href="#">European Centre for Disease Prevention and Control (ECDC)</a>	

List above shows regulatory authorities and their specific areas of science in the European Union

Cross-Cutting Science (the table below is best viewed on a computer browser)

Area	Regulatory Agency (click links for more information)
Chemical mixtures	<a href="#">European Food Safety Authority</a>
Cloning	<a href="#">European Food Safety Authority</a>
Emerging risks	<a href="#">European Food Safety Authority</a>
Endocrine active substances	<a href="#">European Food Safety Authority</a>
Margin of Exposure	<a href="#">European Food Safety Authority</a>
Nanotechnology	<a href="#">European Food Safety Authority</a>
Threshold of Toxicological Concern	<a href="#">European Food Safety Authority</a>
Bee health	<a href="#">European Food Safety Authority</a>
Machine learning	<a href="#">European Food Safety Authority</a>

List above shows regulatory authorities over cross-cutting science in the European Union.

#### Knowledge Check

1) Consumer exposure standards are developed for hazardous substances and articles by the:

- a) U.S. Food and Drug Administration (FDA)
- b) U.S. Consumer Product Safety Commission (CPSC)
- c) General Product Safety Directive (GPSD)

**Answer**

U.S. Consumer Product Safety Commission (CPSC)

2) Exposure standards for pharmaceuticals are:

- a) Issued by the U.S. Food and Drug Administration (FDA)
- b) Developed by the Environmental Protection Agency
- c) Recommended guidance developed by the U.S. Food and Drug Administration (FDA)

**Answer**

Recommended guidance developed by the U.S. Food and Drug Administration (FDA)

3) The FDA develops exposure standards for both direct and indirect food additives. Which of the following is an example of an indirect food additive?

- a) A preservative added to food products
- b) An antibiotic administered to cattle
- c) Natural and artificial flavorings
- d) A nutritional supplement, such as Vitamin A

**Answer**

An antibiotic administered to cattle

4) Under the Delaney Clause of 1958, the FDA:

- a) Required physicians to strictly adhere to exposure standards for pharmaceuticals
- b) Prohibited the addition of any substance to food that has been shown to induce cancer in humans or animals
- c) Authorized the addition of potentially carcinogenic substances to food as long as the concentration is at 0.05 ppm or less

**Answer**

Prohibited the addition of any substance to food that has been shown to induce cancer in humans or animals

5) In the European Union, what regulatory authority is responsible for chemicals and biocides?

- a) European Centre for Disease Prevention and Control (ECDC)
- b) European Food Safety Authority (EFSA)
- c) European Chemicals Agency (ECHA)

**Answer**

European Food Safety Authority (EFSA)

This page titled [7.2: Regulation of Consumer Products and Drug Safety](#) is shared under a [CC BY-NC 4.0](#) license and was authored, remixed, and/or curated by [ToxMSDT Online component](#) via [source content](#) that was edited to the style and standards of the LibreTexts platform.

## Environmental Exposure Standards/Guidelines

The Environmental Protection Agency (EPA) is responsible for US-wide [laws](#) that require determination and enforcement of environmental exposure standards. In addition, EPA has the authority to prepare recommended exposure guidelines for selected environmental pollutants. Similar organizations exist in US states, and in other countries and groups of countries (such as the European Commission for European Union member countries).

The EPA is responsible for developing exposure standards for:

- Pesticides
- Water pollutants
- Air pollutants
- Hazardous wastes

### Pesticides

Pesticides cannot be marketed until they have been registered by the EPA in accordance with the [Federal Insecticide, Fungicide, and Rodenticide Act](#) (FIFRA). In order to obtain registration, a pesticide must undergo an extensive battery of toxicity tests, chemistry analyses, and environmental fate tests.

The [Food Quality Protection Act](#) of 1996 (FQPA) changed the way that pesticides were regulated by requiring investigation of:

- Nonoccupational exposure to pesticides.
- The cumulative effects of pesticides having a common toxicity mechanism.
- Any increased susceptibility in infants, children and other sensitive groups.
- Whether the pesticide has endocrine-disrupting effects.

Certain pesticides have been determined by the EPA to pose minimal risk to health or to the environment and are [exempt](#) from FIFRA registration.

A primary exposure standard for pesticides is the [pesticide tolerance for food use](#). This standard specifies the pesticide residue allowed to remain in or on each treated food product. The EPA residues risk assessment covers:

- Toxicity.
- Amount used and how often.
- How much residue remains by the time a product reaches the market.
- Other ways of being exposed to the pesticide, if any.

Figure 7.3.1 Dusting crops with pesticide  
(Image Source: iStock Photos, ©)

Figure 7.3.2 Aerosol spray cans of pesticide  
(Image Source: iStock Photos, ©)

### Water Pollutants

Access to safe drinking water and control of water pollution are regulated by the [Safe Drinking Water Act](#) (SDWA) and the [Clean Water Act](#) (CWA). Under the SDWA, the EPA conducts risk assessments and issues [Maximum Contaminant Levels \(MCLs\)](#) for naturally-occurring and man-made contaminants in drinking water. The MCL is the acceptable exposure level which, if exceeded, requires immediate water treatment to reduce the contaminant level.

In addition to establishing MCLs, the EPA can propose recommended exposure guidance for drinking water contamination. As an interim procedure, **maximum contaminant level goals (MCLGs)** may be recommended for long-term exposures to contaminants in drinking water. Generally, no allowable exposure can be recommended for a carcinogenic chemical. When the MCL is issued, an acceptable exposure level based on a cancer risk assessment may be proposed for the MCL.

EPA prepares [health advisories \(HAs\)](#) as voluntary exposure guidelines for drinking water contamination. The HAs provide exposure limits for 1-day, 10-day, longer-term, or lifetime exposure periods. They pertain to both cancer and noncancer risks. The formula used to derive a health advisory differs from that for the ADI or RfD in that the HAs pertain to short-term as well as long-term exposures. In addition, human body weight and drinking water consumption are included in the formula.

Data from toxicology studies such as the duration of exposure and the exposure route (such as oral) must be represented in the HAs. For example, the 10-day HA must be based on a NOAEL or LOAEL derivation that was obtained from an animal toxicology study of approximately 10 days duration (routinely 7- to 14-day toxicity studies).

A longer-term HA applies to humans drinking contaminated water for up to 7 years (which could represent 10% of a human's 70-year lifespan). Because 90 days is about 10% of a rat's expected lifespan, the 90-day subchronic study with rats is considered appropriate for providing the basis for the longer-term HA assessment.

A life-time HA (representing lifetime exposure to a toxicant in drinking water) is also determined for noncarcinogens. The procedure uses the RfD risk assessment with adjustments for body weight of an adult human (70 kg) and drinking water consumption of 2 L/day.

Figure 7.3.3 EPA issues health advisories as voluntary exposure guidelines for drinking water contamination  
(Image Source: Adapted from EPA)

In addition to drinking water standards, the EPA is authorized under the Clean Water Act (CWA) to issue exposure guidance for controlling pollution in ground water. The intent is to provide clean water for fishing and swimming rather than for drinking purposes. It provides a scheme for controlling the introduction of pollutants into navigable surface water. The recommendations for ground water protection are known as ambient water quality criteria.

The **ambient water quality criteria** are intended to control pollution sources at the point of release into the environment. While these criteria may be less restrictive than the drinking water standards, they usually are the same numeric value. For example, the MCL for drinking water and the ambient water quality criteria for ground water for lead are the same: 0.05 mg/L of water.

Figure 7.3.4. A scientist tests the water for toxicity  
(Image Source: iStock Photos, ©)

### Air Pollutants

Air emission standards are issued by EPA under the [Clean Air Act](#) (CAA). The CAA authorizes the issuance of **National Ambient Air Quality Standards (NAAQS)** for air pollution. There are two types of NAAQS:

1. **Primary NAAQS standards** set limits to protect public health, including people at increased risk (preexisting heart or lung disease, children, older adults).
2. **Secondary NAAQS standards** relate to public welfare, such as crops, animals, and structures.

NAAQS have been established for the following major atmospheric pollutants:

- Carbon monoxide
- Sulfur oxide
- Oxides of nitrogen
- Ozone
- Hydrocarbons
- Particulates
- Lead

When air emissions exceed the NAAQS levels, the polluting industry must take action to reduce emissions to acceptable levels.

Figure 7.3.5. A factory releases pollutants into the air  
(Image Source: iStock Photos, ©)

## Hazardous Wastes

Hazardous wastes are regulated under the [Resource Conservation and Recovery Act \(RCRA\)](#) and the [Comprehensive Environmental Response, Compensation and Liability Act \(CERCLA\)](#), commonly known as **Superfund**. RCRA regulates hazardous and nonhazardous solid waste, including chemical waste produced by industrial processes, medical waste, and underground storage tanks.

The main purpose of CERCLA is to clean up hazardous waste disposal sites. EPA has established standards known as [Reportable Quantities \(RQs\)](#). Companies must report to EPA any chemical release that exceeds the RQ. RQs evaluate physical, chemical, and toxicological properties of a substance. These are called **primary criteria** and include aquatic toxicity, acute mammalian toxicity (oral, dermal, and inhalation), ignitability, reactivity, chronic toxicity, and potential carcinogenicity. **Secondary criteria** evaluate how a substance degrades in the environment.

[Minimal Risk Levels \(MRLs\)](#) for noncancer toxic effects are derived by the [Agency for Toxic Substances and Disease Registry \(ATSDR\)](#), which has a congressional mandate to investigate the health effects of hazardous substances in the environment. MRLs are estimates of daily human exposures that are likely to be without an appreciable risk of adverse effects over a specified duration of exposure. MRLs are derived for acute (14 days or less), intermediate (15–364 days), and chronic (365 days or more) exposures for inhalation or oral routes.

### Knowledge Check

1) The exposure standard established by the EPA for the pesticide residue allowed to remain in or on each treated food product is called the:

- a) Pesticide tolerance for food use
- b) Reportable quantity of pesticides
- c) Maximum Contaminant Level (MCL)

#### Answer

Pesticide tolerance for food use - **This is the correct answer.**

The pesticide tolerance for food use standard established by the EPA specifies the pesticide residue allowed to remain in or on treated food products.

2) The EPA establishes exposure standards for natural and man-made contaminants in drinking water. These standards are called:

- a) Ambient Water Quality Criteria
- b) Maximum Contaminant Level Goals (MCLGs)
- c) Maximum Contaminant Levels (MCLs)

#### Answer

Maximum Contaminant Levels (MCLs)- **This is the correct answer.**

The EPA conducts risk assessments and issues Maximum Contaminant Levels (MCLs) for naturally-occurring and man-made contaminants in drinking water.

3) What is the difference between primary National Ambient Air Quality Standards (NAAQS) and secondary NAAQS?

- a) Primary NAAQS relate to public welfare (for example, crops, animals, and structures); secondary NAAQS set limits to protect public health
- b) Primary NAAQS set limits to protect public health; secondary NAAQS relate to public welfare
- c) Primary NAAQS are legally enforceable; secondary NAAQS are not

#### Answer

Primary NAAQS set limits to protect public health; secondary NAAQS relate to public welfare - **This is the correct answer.**

Primary NAAQS set limits to protect public health. Secondary NAAQS relate to public welfare, such as crops, animals, and structures.

4) The Agency for Toxic Substances and Disease Registry (ATSDR) estimates levels for daily human exposure to chemicals that are likely to be without an appreciable risk of adverse effects for specified periods of exposure. These are known as:

- a) Minimal Risk Levels (MRLs)
- b) Maximum Contaminant Levels (MCLs)
- c) Reportable Quantities (RQs)

#### Answer

Minimal Risk Levels (MRLs) - **This is the correct answer.**

Minimal Risk Levels (MRLs) for noncancer toxic effects estimate the daily human exposures that are likely to be without an appreciable risk of adverse effects over a specific duration of exposure.

This page titled [7.3: Environmental Exposure Standards/Guidelines](#) is shared under a [CC BY-NC 4.0](#) license and was authored, remixed, and/or curated by [ToxMSDT Online component](#) via [source content](#) that was edited to the style and standards of the LibreTexts platform.

## 7.4: Occupational (Workplace) Exposure Standards/Guidelines/Approaches

# Occupational Safety and Health Administration (OSHA) Standards

Recommended or mandatory **occupational exposure limits (OELs)** for chemicals exist in many countries. For example, legal standards in the United States are established by the Occupational Safety and Health Administration (OSHA). These standards are known as [Permissible Exposure Limits \(PELs\)](#). The majority of PELs were issued after the 1970 [Occupational Safety and Health \(OSH\) Act](#).

OSHA maintains the "Permissible Exposure Limits – Annotated Tables" that contain comparative information taken from federal, state, and professional organizations such as the:

- California Division of Occupational Safety and Health (Cal/OSHA) PELs.
- ACGIH® (formerly known as the [American Conference of Governmental Industrial Hygienists](#)) Threshold Limit Values (TLVs®).
- [National Institute for Occupational Safety and Health](#) (NIOSH) Recommended Exposure Limits (RELs).

These tables list air concentration limits for chemicals but do not include notations for skin absorption or sensitization. The PEL Annotated Tables include the following: [Table Z-1](#), [Table Z-2](#), and [Table Z-3](#).

Figure 7.4.1. Screenshot of a portion of OSHA PEL Annotated Table Z-2

Most OSHA PELs are for airborne substances with allowable exposure limits averaged over an 8-hour day in a 40-hour week. This is known as the **Time-Weighted-Average (TWA) PEL**. While adverse effects are not expected to be encountered with repeated exposures at the PEL, OSHA recommends that employers consider using the **alternative occupational exposure limits** because it believes levels above some of the alternative occupational exposure limits may be hazardous to workers even when the exposure levels are in compliance with the relevant PELs.

## Short Term Exposure Limits, Ceiling Limits, and Skin Designations

OSHA also issues Short Term Exposure Limit (STELs) PELs, Ceiling Limits, and PELs that carry a skin designation.

- [Short Term Exposure Limit \(STELs\)](#) -- PEL STELs are concentration limits of substances in the air that a worker may be exposed to for 15 minutes without suffering adverse effects. The 15-minute STEL is usually considerably higher than the 8-hour TWA exposure level.
- [Ceiling Limits](#) are concentration limits for airborne substances that should never be exceeded.
- A [skin designation](#) indicates that the substance can be readily absorbed through the skin, eye or mucous membranes, and substantially contribute to the dose that a worker receives from inhalation of the substance. OSHA standards do not include surface contamination criteria or quantifications for skin absorption.

Theoretically, an occupational substance could have PELs as TWA, STEL, and Ceiling Value, and with a skin designation, but that is rare. Usually, an OSHA-regulated substance will have only a PEL as a time-weighted average.

## Immediately Dangerous to Life or Health (IDLH)

The **Immediately Dangerous to Life or Health (IDLH)** occupational exposure guideline was developed jointly by the OSHA and NIOSH [Standards Completion Program](#) in 1974. IDLH represents:

- An airborne exposure "likely to cause death or immediate or delayed permanent adverse health effects or prevent escape from such an environment" (NIOSH).
- "An atmosphere that poses an immediate threat to life, would cause irreversible adverse health effects, or would impair an individual's ability to escape from a dangerous atmosphere" (OSHA).

IDLH values can be used in assigning respiratory protection equipment.

## Recommended Exposure Limits and Biological Exposure Indices

The NIOSH **Recommended Exposure Limits** (RELs) are also designated as time-weighted average, short-term exposure limits, and ceiling limits. NIOSH also uses immediately dangerous to life or health (IDLH) values.

ACGIH® also has developed **Biological Exposure Indices (BEIs®)** as guidance values for assessing biological monitoring results (concentration of a chemical in biological media such as blood or urine). The OSHA [Policy Statement](#) on the Uses of TLVs® and BEIs® provides an overview on using these guidelines.

## Control Banding (CB)

**Control banding (CB)** is an emerging area internationally for guiding the assessment and management of workplace chemical risks. CB is a technique that determines a control measure such as dilution by air ventilation or engineering controls based on a range or “band” of hazards such as skin irritation or carcinogenic potential and exposures such as an assessment of a small, medium, or large exposure. It is based on the fact that there are a limited number of control approaches, and a history of having many problems solved in the past. CB is used with other health and safety practices such as chemical substitution. It is not a replacement for the use of experts in occupational safety and health and it does not eliminate the need to perform exposure monitoring.

### Knowledge Check

1) The Occupational Safety and Health Administration (OSHA) develops legal standards for workplace exposure. These standards are called:

- a) Threshold Limit Values (TLVs)
- b) Recommended Exposure Limits (RELs)
- c) Permissible Exposure Limits (PELs)

#### Answer

Permissible Exposure Limits (PELs)

OSHA establishes Permissible Exposure Limits, or PELs, which are legal standards for workplace exposure.

2) What exposure standards can be used to assign respiratory protection equipment?

- a) Immediately Dangerous to Life or Health (IDLH)
- b) Short Term Exposure Limits (STELs)
- c) Biological Exposure Indices (BEIs)

#### Answer

Immediately Dangerous to Life or Health (IDLH)

Immediately Dangerous to Life or Health (IDLH) values can be used in assigning respiratory protection equipment.

This page titled [7.4: Occupational \(Workplace\) Exposure Standards/Guidelines/Approaches](#) is shared under a [CC BY-NC 4.0](#) license and was authored, remixed, and/or curated by [ToxMSDT Online component](#) via [source content](#) that was edited to the style and standards of the LibreTexts platform.



## CHAPTER OVERVIEW

### Section 8: Basic Physiology

## Learning Objectives

After completing this lesson, you will be able to:

- Explain the basic functional and structural organization of the human body.
- Describe homeostasis.
- Explain the role of the four types of tissues in the human body.
- Explain the role of physiological chemicals in normal body functions.

## In this section...

Topics include:

- [8.1: Introduction to Basic Physiology](#)
- [8.2: Homeostasis](#)
- [8.3: Organs and Organ Systems](#)
- [8.4: Tissues](#)
- [8.5: Cells](#)
- [8.6: Chemicals](#)

## Section 8: Key Points

## What We've Covered

This section made the following main points:

- In most cases, toxic substances exert their harmful effects directly on specific cells or biochemicals within the affected organ (specific toxic effects).
- Homeostasis is the ability of the body to maintain relative stability and function despite drastic changes in the external environment or one portion of the body. The primary components of homeostasis include:
  - Stimulus — a change in the environment.
  - Receptor — the site within the body that detects or receives the stimulus.
  - Control center — the operational point at which the signals are received, analyzed, and an appropriate response is determined.
  - Effector — the body site where a response is generated.
  - Feedback mechanisms — methods by which the body regulates the response
- The basic structure and functional organization of the human body is:  
Chemicals → Cells → Tissues → Organs → Organ Systems → Organism
- The human body consists of eleven organ systems.
- Tissues in organs are precisely arranged to work in harmony to perform organ functions.
- There are four types of tissues in the body:
  1. Epithelial tissue protects, absorbs, and secretes substances, and detects sensations.
  2. Connective tissue provides support and holds body tissues together.
  3. Muscle tissue has the ability to contract.

4. Nerve tissue conducts electrical impulses and conveys information from one area of the body to another.
- The cell is the smallest component of the body that can perform all of the basic life functions.
  - Cell components that are most susceptible to cellular damage include the cell membrane, nucleus, ribosomes, peroxisomes, lysosomes, and mitochondria.
  - The three categories of physiological chemicals normally functioning in the body are:
    1. Elements — made up of only one atom (examples include hydrogen and oxygen).
    2. Inorganic compounds — simple molecules made up of one or two different elements (examples include water and carbon dioxide).
    3. Organic compounds — contain covalently-bonded carbon and hydrogen and often other elements (examples include DNA, RNA, ATP, and proteins).
- 

This page titled [Section 8: Basic Physiology](#) is shared under a [CC BY-NC 4.0](#) license and was authored, remixed, and/or curated by [ToxMSDT Online component](#) via [source content](#) that was edited to the style and standards of the LibreTexts platform.

## 8.1: Introduction to Basic Physiology

---

# Introduction to Basic Physiology

In order to understand how toxic substances cause harmful changes in organs, tissues, or cells, knowledge of normal physiology and anatomy is needed. This section is an overview of normal physiology, especially as related to the normal body components and how they function. While we show how some xenobiotics can damage the different body components, detailed examples of toxic cellular and biochemical reactions will be covered in later sections.

## Complexity of the Body

The body is immensely complex with numerous components, all of which perform precise functions necessary for the body to maintain health and well-being. Malfunction of any component can result in disease or a breakdown of a portion of the body. Toxic substances can damage an organ or organ system so that it cannot function properly, leading to death or sickness of the organism (for example, liver or kidney failure). However, in nearly all cases, the toxic substance actually exerts its harmful effect directly on specific cells or biochemicals within the affected organ. These cell and chemical changes in turn cause the tissue or organ to malfunction.

## Specific Toxic Effects

Most toxic substances are usually specific in their toxic damage to particular tissues or organs, referred to as the "target tissues" or "target organs." Toxic effects may affect only a specific type of cell or biochemical reaction. For example:

- The toxic effect of carbon monoxide is due to its binding to a specific molecule (hemoglobin) of a specific cell (red blood cell).
- Organophosphate toxic substances, which inhibit an enzyme (acetylcholinesterase) responsible for modulating neurotransmission at nerve endings.

## Systemic Toxic Effects

On the other hand, the effect of some toxic substances may be generalized and potentially damage all cells and thus all tissues and all organs.

- An example is the production of free radicals by whole body radiation. Radiation interacts with cellular water to produce highly reactive free radicals that can damage cellular components. The result can be a range of effects from the death of the cell, to cell malfunction, and to the failure of normal cell division (for example, cancer).
- An example of a multi-organ chemical toxic substance is lead, which damages several types of cells, including kidney cells, nerve cells, and red blood cells.

The body is a remarkable complex living "machine" consisting of trillions of cells and multitudes of biochemical reactions. Each cell has a specific function and cells work together to promote the health and vitality of the organism. The number and types of toxic reactions are likewise very large. While this tutorial cannot possibly present all these types of cellular and biochemical toxic reactions, it is our goal to provide an overview of the primary toxic mechanisms with a few examples that illustrate these mechanisms. It is important to understand that changes at one level in the body can affect homeostasis at several other levels.

---

This page titled [8.1: Introduction to Basic Physiology](#) is shared under a [CC BY-NC 4.0](#) license and was authored, remixed, and/or curated by [ToxMSDT Online component](#) via [source content](#) that was edited to the style and standards of the LibreTexts platform.

## 8.2: Homeostasis

# Homeostasis

**Homeostasis** is the ability of the body to maintain relative stability and function even though drastic changes may take place in the external environment or in one portion of the body. A series of control mechanisms, some functioning at the organ or tissue level and other centrally controlled, maintain homeostasis. The major central homeostatic controls are the nervous and endocrine systems.

Physical and mental stresses, injury, and disease continually challenge us and any of them can interfere with homeostasis. When the body loses its homeostasis, it may plunge out of control, into dysfunction, illness, and even death. Homeostasis at the tissue, organ, organ system, and organism levels reflects the combined and coordinated actions of many cells. Each cell contributes to maintaining homeostasis.

## Maintaining Homeostasis

To maintain homeostasis, the body reacts to an abnormal change (induced by a toxic substance, biological organism, or other stress) and makes certain adjustments to counter the change (a defense mechanism). The primary components responsible for the maintenance of homeostasis include:

- **Stimulus** — a change in the environment, such as an irritant, loss of blood, or presence of a foreign chemical.
- **Receptor** — the site within the body that detects or receives the stimulus, senses the change from normal, and sends signals to the control center.
- **Control center** — the operational point at which the signals are received, analyzed, and an appropriate response is determined. This is sometimes referred to as the integration center since it integrates the signals with other information to determine if a response is needed and the nature of a response.
- **Effector** — the body site where a response is generated, which counters the initial stimulus and thus attempts to maintain homeostasis.
- **Feedback mechanisms** — methods by which the body regulates the degree of response that has been elicited. A negative feedback depresses the stimulus to shut off or reduce the effector response, whereas a positive feedback has the effect of increasing the effector response.

## Example: Reaction to a Toxin

An example of a homeostatic mechanism can be illustrated by the body's reaction to a toxin that causes anemia and hypoxia (low tissue oxygen) (Figure 1). The production of red blood cells (**erythropoiesis**) is controlled primarily by the hormone, erythropoietin. When the body goes into a state of hypoxia (the stimulus), it prompts the heme protein (the receptor) that signals the kidney to produce erythropoietin (the effector). This, in turn, stimulates the bone marrow to increase red blood cells and hemoglobin, raising the ability of the blood to transport oxygen and thus raises the tissue oxygen levels in the blood and other tissues. This rise in tissue oxygen levels serves to suppress further erythropoietin synthesis (feedback mechanism). In this example, cells and chemicals interact to produce changes that can either disturb homeostasis or restore homeostasis. Toxic substances that damage the kidney can interfere with the production of erythropoietin or toxic substances that damage the bone marrow can prevent the production of red blood cells. This interferes with the homeostatic mechanism described resulting in anemia.

Figure 8.2.1. Homeostatic mechanism to restore levels of red blood cells  
(Image Source: NLM)

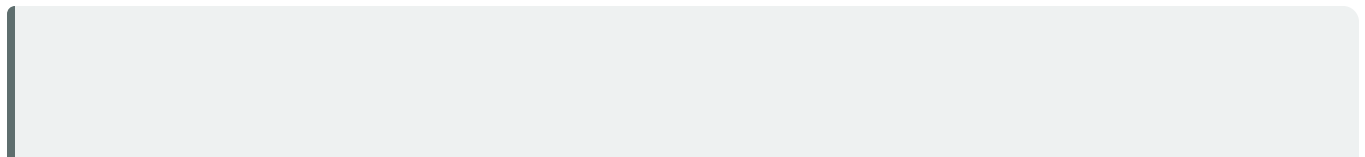

 Knowledge Check

1) The ability of the body to maintain relative stability and function even though drastic changes may take place in the external environment or in one portion of the body is known as:

- a) Physiology
- b) Homeostasis
- c) Toxicity

**Answer**

Legally enforceable acceptable exposure levels or controls

2) To maintain homeostasis, the body reacts to an abnormal change (*induced by a toxin, biological organism, or other stress*) and makes certain adjustments to counter the change (*a defense mechanism*). The component of the homeostasis process which detects the change in the environment is known as the:

- a) Effector
- b) Stimulus
- c) Receptor

**Answer**

Recommended maximum exposure levels which are voluntary and not legally enforceable

This page titled [8.2: Homeostasis](#) is shared under a [CC BY-NC 4.0](#) license and was authored, remixed, and/or curated by [ToxMSDT Online component](#) via [source content](#) that was edited to the style and standards of the LibreTexts platform.

## 8.3: Organs and Organ Systems

# Organ Systems and Organs

Before one can understand how xenobiotics affect these different body components, it's important to understand normal body components and how they function. For this reason, this section provides a basic overview of anatomy and physiology as it relates to toxicity mechanisms.

## Basic Body Structure and Organization

We can think of the basic structure and functional organization of the human body as a pyramid or hierarchical arrangement in which the lowest level of organization (the foundation) consists of cells and chemicals. Organs and organ systems represent the highest levels of the body's organization (Figure 1).

Figure 8.3.1. Pyramid represents a hierarchical organization of human body components (Image Source: NLM)

Simplified definitions of the various levels of organization within the body are:

- **Organ system** — a group of organs that contribute to specific functions within the body. Examples include:
  - Gastrointestinal system
  - Nervous system
- **Organ** — a group of tissues precisely arranged so that they can work together to perform specific functions. Examples include:
  - Liver
  - Brain
- **Tissue** — a group of cells with similar structure and function. There are only four types of tissues:
  1. Epithelial
  2. Connective
  3. Muscle
  4. Nerve
- **Cell** — the smallest living units in the body. Examples include:
  - Hepatocyte
  - Neuron
- **Chemicals** — atoms or molecules that are the building blocks of all matter. Examples include:
  - Oxygen
  - Protein

## Organ Systems of the Human Body

The human body consists of eleven organ systems, each of which contains several specific organs. An organ is a unique anatomic structure consisting of groups of tissues that work in concert to perform specific functions. Table 1 includes the structures and functions of these eleven organ systems.

Organ Systems of the Human Body		
Organ System	Functions	Organs
	<ul style="list-style-type: none"> <li>• Barrier to invading organisms and chemicals</li> </ul>	<ul style="list-style-type: none"> <li>• Skin</li> <li>• Hair</li> </ul>

<b>Integumentary</b>	<ul style="list-style-type: none"> <li>• Temperature control</li> </ul>	<ul style="list-style-type: none"> <li>• <u>Subcutaneous tissue</u></li> </ul>
<b>Skeletal</b>	<ul style="list-style-type: none"> <li>• Supports and moves body</li> <li>• Protects internal <u>organs</u></li> <li>• Mineral storage</li> <li>• Blood formation</li> </ul>	<ul style="list-style-type: none"> <li>• Bones</li> <li>• Cartilage</li> <li>• Ligaments</li> <li>• <u>Bone marrow</u></li> </ul>
<b>Muscular</b>	<ul style="list-style-type: none"> <li>• Locomotion</li> <li>• Heat production</li> </ul>	<ul style="list-style-type: none"> <li>• Muscles</li> <li>• Tendons</li> </ul>
<b>Nervous</b>	<ul style="list-style-type: none"> <li>• Coordinates activities of other <u>organ systems</u></li> <li>• Responds to sensations</li> </ul>	<ul style="list-style-type: none"> <li>• Brain</li> <li>• Spinal cord</li> <li>• Nerves</li> <li>• Eyes</li> <li>• Ears</li> </ul>
<b>Endocrine</b>	<ul style="list-style-type: none"> <li>• Regulates body functions by <u>chemicals (hormones)</u></li> </ul>	<ul style="list-style-type: none"> <li>• Pituitary gland</li> <li>• Parathyroid gland</li> <li>• Thyroid gland</li> <li>• Adrenal gland</li> <li>• Thymus</li> <li>• Pancreas</li> <li>• Gonads</li> </ul>
<b>Cardiovascular</b>	<ul style="list-style-type: none"> <li>• Transports oxygen and nutrients to <u>tissues</u></li> <li>• Removes waste products</li> </ul>	<ul style="list-style-type: none"> <li>• Heart</li> <li>• Blood</li> <li>• Blood vessels</li> </ul>
<b>Lymphatic</b>	<ul style="list-style-type: none"> <li>• Returns <u>tissue</u> fluid to blood</li> <li>• Defends against foreign organisms</li> </ul>	<ul style="list-style-type: none"> <li>• Spleen</li> <li>• Lymph nodes</li> <li>• Thymus</li> <li>• Lymphatic vessels</li> </ul>
<b>Respiratory</b>	<ul style="list-style-type: none"> <li>• Oxygen/carbon dioxide exchange</li> </ul>	<ul style="list-style-type: none"> <li>• Lungs</li> <li>• Trachea</li> <li>• Larynx</li> <li>• Nasal cavities</li> <li>• Pharynx</li> </ul>
<b>Digestive</b>	<ul style="list-style-type: none"> <li>• Processes foods</li> <li>• <u>Absorption</u> of nutrients into body</li> </ul>	<ul style="list-style-type: none"> <li>• Stomach</li> <li>• Intestinal tract</li> <li>• Liver</li> <li>• Pancreas</li> <li>• Esophagus</li> <li>• Salivary glands</li> </ul>
<b>Urinary</b>	<ul style="list-style-type: none"> <li>• <u>Elimination</u> of wastes</li> <li>• Regulates pH and volume of blood</li> </ul>	<ul style="list-style-type: none"> <li>• Kidneys</li> <li>• Urinary bladder</li> <li>• Urethra</li> </ul>
<b>Reproductive</b>	<ul style="list-style-type: none"> <li>• Produces <u>germ cells (eggs and sperm)</u></li> <li>• Environment for growth of <u>fetus (female)</u></li> </ul>	<ul style="list-style-type: none"> <li>• Ovaries</li> <li>• Uterus</li> <li>• Mammary glands</li> <li>• Testes</li> <li>• Prostate gland</li> <li>• External genitalia</li> </ul>

## Organ Systems of the Human Body

The human body consists of eleven organ systems, each of which contains several specific organs. An organ is a unique anatomic structure consisting of groups of tissues that work in concert to perform specific functions. Table 1 includes the structures and functions of these eleven organ systems.

Organ System	Functions	Organs
--------------	-----------	--------

<b>Integumentary</b>	<ul style="list-style-type: none"> <li>• Barrier to invading organisms and <u>chemicals</u></li> <li>• Temperature control</li> </ul>	<ul style="list-style-type: none"> <li>• Skin</li> <li>• Hair</li> <li>• Subcutaneous <u>tissue</u></li> </ul>
<b>Skeletal</b>	<ul style="list-style-type: none"> <li>• Supports and moves body</li> <li>• Protects internal <u>organs</u></li> <li>• Mineral storage</li> <li>• Blood formation</li> </ul>	<ul style="list-style-type: none"> <li>• Bones</li> <li>• Cartilage</li> <li>• Ligaments</li> <li>• <u>Bone marrow</u></li> </ul>
<b>Muscular</b>	<ul style="list-style-type: none"> <li>• Locomotion</li> <li>• Heat production</li> </ul>	<ul style="list-style-type: none"> <li>• Muscles</li> <li>• Tendons</li> </ul>
<b>Nervous</b>	<ul style="list-style-type: none"> <li>• Coordinates activities of other <u>organ systems</u></li> <li>• Responds to sensations</li> </ul>	<ul style="list-style-type: none"> <li>• Brain</li> <li>• Spinal cord</li> <li>• Nerves</li> <li>• Eyes</li> <li>• Ears</li> </ul>
<b>Endocrine</b>	<ul style="list-style-type: none"> <li>• Regulates body functions by <u>chemicals</u> (<i>hormones</i>)</li> </ul>	<ul style="list-style-type: none"> <li>• Pituitary gland</li> <li>• Parathyroid gland</li> <li>• Thyroid gland</li> <li>• Adrenal gland</li> <li>• Thymus</li> <li>• Pancreas</li> <li>• Gonads</li> </ul>
<b>Cardiovascular</b>	<ul style="list-style-type: none"> <li>• Transports oxygen and nutrients to <u>tissues</u></li> <li>• Removes waste products</li> </ul>	<ul style="list-style-type: none"> <li>• Heart</li> <li>• Blood</li> <li>• Blood vessels</li> </ul>
<b>Lymphatic</b>	<ul style="list-style-type: none"> <li>• Returns <u>tissue</u> fluid to blood</li> <li>• Defends against foreign organisms</li> </ul>	<ul style="list-style-type: none"> <li>• Spleen</li> <li>• Lymph nodes</li> <li>• Thymus</li> <li>• Lymphatic vessels</li> </ul>
<b>Respiratory</b>	<ul style="list-style-type: none"> <li>• Oxygen/carbon dioxide exchange</li> </ul>	<ul style="list-style-type: none"> <li>• Lungs</li> <li>• Trachea</li> <li>• Larynx</li> <li>• Nasal cavities</li> <li>• Pharynx</li> </ul>
<b>Digestive</b>	<ul style="list-style-type: none"> <li>• Processes foods</li> <li>• <u>Absorption</u> of nutrients into body</li> </ul>	<ul style="list-style-type: none"> <li>• Stomach</li> <li>• Intestinal tract</li> <li>• Liver</li> <li>• Pancreas</li> <li>• Esophagus</li> <li>• Salivary glands</li> </ul>
<b>Urinary</b>	<ul style="list-style-type: none"> <li>• <u>Elimination</u> of wastes</li> <li>• Regulates pH and volume of blood</li> </ul>	<ul style="list-style-type: none"> <li>• Kidneys</li> <li>• Urinary bladder</li> <li>• Urethra</li> </ul>
<b>Reproductive</b>	<ul style="list-style-type: none"> <li>• Produces <u>germ cells</u> (<i>eggs and sperm</i>)</li> <li>• Environment for growth of <u>fetus</u> (<i>female</i>)</li> </ul>	<ul style="list-style-type: none"> <li>• Ovaries</li> <li>• Uterus</li> <li>• Mammary glands</li> <li>• Testes</li> <li>• Prostate gland</li> <li>• External genitalia</li> </ul>

Table 8.3.1. Organ systems of the human body



 Knowledge Check

1) Groups of cells with similar structure and function are known as:

- a) Tissues
- b) Organs
- c) Organ systems

**Answer**

Tissues - **This is the correct answer.**

Tissues are groups of cells with similar structure and function. There are only four types of tissues: epithelial tissue, connective tissue, muscle tissue, and nerve tissue.

2) The organ system that transports oxygen and nutrients to tissues and removes waste products is the:

- a) Urinary system
- b) Integumentary system
- c) Cardiovascular system

**Answer**

Cardiovascular system - **This is the correct answer.**

The cardiovascular system functions to transport oxygen and nutrients to tissues and removes waste products. The primary organs are the heart, blood, and blood vessels.

3) The organ system that regulates body functions by chemicals (hormones) is known as the:

- a) Nervous system
- b) Reproductive system
- c) Endocrine system

**Answer**

Endocrine system - **This is the correct answer.**

The endocrine system functions to regulate body functions by chemicals (hormones). It contains several organs including the pituitary gland, parathyroid gland, thyroid gland, adrenal gland, thymus, pancreas, and gonads.

This page titled [8.3: Organs and Organ Systems](#) is shared under a [CC BY-NC 4.0](#) license and was authored, remixed, and/or curated by [ToxMSDT Online component](#) via [source content](#) that was edited to the style and standards of the LibreTexts platform.

## 8.4: Tissues

# Tissues

There are four types of tissues dispersed throughout the body, as described below. A type of tissue is not unique for a particular organ and all types of tissue are present in most organs, just as certain types of cells are found in many organs. For example, nerve cells and circulating blood cells are present in virtually all organs.

## An "Orchestra" of Tissues

Tissues in organs are precisely arranged so that they can work in harmony in performing organ functions. This is similar to an orchestra that contains various musical instruments, each of which is located in a precise place and contributes exactly at the right time to create harmony. Like musical instruments that are mixed and matched in various types of musical groups, tissues and cells also are present in several different organs and contribute their part to the function of the organ and the maintenance of homeostasis.

## Kinds of Tissues in the Body

The four types of tissues are:

1. Epithelial tissue
2. Connective tissue
3. Muscle tissue
4. Nerve tissue

The four types of tissues are similar in that each consists of cells and extracellular materials. However, the types of tissues have different types of cells and differ in the percentage composition of cells and the extracellular materials. Figure 1 illustrates how tissues fit into the hierarchy of body components.

Figure 8.4.1. Hierarchy of body components  
(Image Source: NLM)

## Epithelial Tissue

**Epithelial tissue** is specialized to protect, absorb, and secrete substances, as well as detect sensations. It covers every exposed body surface, forms a barrier to the outside world, and controls absorption. Epithelium forms most of the surface of the skin, and the lining of the intestinal, respiratory, and urogenital tracts. Epithelium also lines internal cavities and passageways such as the chest, brain, eye, inner surfaces of blood vessels, the heart, and the inner ear.

Functions of epithelium include:

- Providing physical protection from abrasion, dehydration, and damage by xenobiotics.
- Controlling the permeability of substances in entering or leaving the body.
  - Some epithelia are relatively impermeable; others are readily crossed.
  - Various toxins can damage this epithelial barrier.
- Detecting sensation (sight, smell, taste, equilibrium, and hearing) and conveying this information to the nervous system.
  - For example, touch receptors in the skin respond to pressure by stimulating adjacent sensory nerves.

The epithelium also contains glands and secretes substances such as sweat or digestive enzymes. Others secrete substances into the blood (hormones), such as the pancreas, thyroid, and pituitary gland.

The epithelial cells are classified according to the shape of the cell and the number of cell layers. Three primary cell shapes exist: squamous (flat), cuboidal, and columnar. There are two types of layering: 1) simple and 2) stratified. Figure 2 illustrates these types of epithelial cells.

Figure 8.4.2. Classification of epithelial tissues  
(Source: Adapted from iStock Photos, ©)

## Connective Tissue

**Connective tissues** provide support and hold the body tissues together. They contain more intercellular substances than the other tissues. Connective tissues include blood; bone; cartilage; adipose (fat); and the fibrous and areolar (loose) connective tissues that give support to most organs. The blood and lymph vessels are immersed in the connective tissue media of the body. The blood-vascular system is a component of connective tissue.

In addition to connecting, the connective tissue plays a major role in protecting the body from outside invaders. The hematopoietic tissue is a form of connective tissue responsible for the manufacture of all the blood cells and immunological capability. Phagocytes are connective tissue cells and produce antibodies. If invading organisms or xenobiotics get through the epithelial protective barrier, the connective tissue acts to defend against them.

Figure 8.4.3. Connective tissues  
(Image Source: Adapted from Wikimedia Commons, Public Domain)

## Muscle Tissue

**Muscular tissue** is specialized for an ability to contract. Muscle cells are elongated and called muscle fibers. When one end of a muscle cell receives a stimulus, a wave of excitation is conducted through the entire cell so that all parts contract in harmony. There are three types of muscle cells:

1. **Skeletal muscle** — attached to bone and contracts causing the bones to move.
2. **Cardiac muscle** — contracts to force blood out of the heart and around the body.
3. **Smooth muscle** — can be found in several organs, including the digestive tract, reproductive organs, respiratory tract, and the lining of the bladder. Examples of smooth muscle activity are the:
  - Contraction of the bladder to force urine out.
  - Peristaltic movement to move feces down the digestive system.
  - Contraction of smooth muscle in the trachea and bronchi which decreases the size of the air passageway.

Figure 8.4.4. Muscle tissues  
(Image Source: Adapted from iStock Photos, ©)

## Nerve Tissue

**Nervous tissue** is specialized with a capability to conduct electrical impulses and convey information from one area of the body to another. Most of the nervous tissue (98%) is located in the central nervous system, the brain, and spinal cord.

There are two types of nervous tissue: 1) neurons and 2) neuroglia. Neurons (Figure 5) actually transmit the impulses. Neuroglia (Figure 6) provide physical support for the neural tissue, control tissue fluids around the neurons, and help defend the neurons from invading organisms and xenobiotics. Receptor nerve endings of neurons react to various kinds of stimuli (for example, light, sound, touch, and pressure) and can transmit waves of excitation from the farthest point in the body to the central nervous system.

Figure 8.4.5. Human neuron anatomy  
(Image Source: Adapted from iStock Photos, ©)

Figure 8.4.6. Types of neuroglia

(Image Source: Adapted from Wikimedia Commons. Blausen.com staff (2014). "Medical gallery of Blausen Medical 2014". *WikiJournal of Medicine* 1 (2). DOI:[10.15347/wjm/2014.010](https://doi.org/10.15347/wjm/2014.010). ISSN [2002-4436](https://doi.org/10.2002-4436). [View original image.](#))

#### Knowledge Check

1) There are only four types of tissues in the body. The type of tissue that is specialized to protect, absorb and secrete substances, detect sensations, covers every exposed body surface, and forms a barrier to the outside world is:

- a) Nerve tissue
- b) Epithelial tissue
- c) Connective tissue
- d) Muscle tissue

#### Answer

Epithelial tissue

Epithelial tissue is specialized to protect, absorb and secrete substances, and detect sensations. It covers every exposed body surface, forms a barrier to the outside world and controls absorption. Epithelium forms most of the surface of the skin, and the lining of the intestinal, respiratory, and urogenital tracts. Epithelium also lines internal cavities and passageways such as the chest, brain, eye, inner surfaces of blood vessels, and heart and inner ear.

This page titled [8.4: Tissues](#) is shared under a [CC BY-NC 4.0](#) license and was authored, remixed, and/or curated by [ToxMSDT Online component](#) via [source content](#) that was edited to the style and standards of the LibreTexts platform.

## 8.5: Cells

# Cells

Cells are the smallest component of the body that can perform all of the basic life functions. Each cell performs specialized functions and plays a role in the maintenance of homeostasis. While each cell is an independent entity, it is highly affected by damage to neighboring cells. These various cell types combine to form tissues, which are collections of specialized cells that perform a relatively limited number of functions specific to that type of tissue. Several trillion cells make up the human body. These cells are of various types, which can differ greatly in size, appearance, and function.

## Primary Cell Components

While there are approximately 200 types of cells, they all have similar features: cell membrane, cytoplasm, organelles, and nucleus. The only exception is that the mature red blood cell does not contain a nucleus. Toxins can injure any of the components of the cell causing cell death or damage and malfunction.

Figure 1 shows the various components of a composite cell.

Figure 8.5.1. Basic cell structure

(Image Source: adapted from National Cancer Institute - [SEER Training](#))

The primary components of a typical cell include the following:

- **Cell membrane** — a phospholipid bilayer which also contains cholesterol and proteins; its functions are to provide support and to control entrance and exit of all materials. We will discuss the structure of the cell membrane and the mechanisms by which chemicals can penetrate or be absorbed into or out of the cell in the [Introduction to Absorption](#) section later in ToxTutor.
- **Cytoplasm** — a watery solution of minerals, organic molecules, and gases found between the cell membrane and nucleus.
- **Nucleus** — a membrane-bound part of a cell that contains nucleotides, enzymes, and nucleoproteins; the nucleus controls metabolism, protein synthesis, and the storage and processing of genetic information.
- **Cytosol** — the liquid part of the cytoplasm which distributes materials by diffusion throughout the cell.
- **Nucleolus** — a dense region of the nucleus which contains the RNA and DNA; It is the site for rRNA synthesis and assembly of the ribosome components.
- **Endoplasmic reticulum** — an extensive network of membrane-like channels that extends throughout the cytoplasm; it synthesizes secretory products and is responsible for intracellular storage and transport.
- **Ribosomes** — very small structures that consist of RNA and proteins and perform protein synthesis; some ribosomes are fixed (bound to the endoplasmic reticulum) while other ribosomes are free and scattered within the cytoplasm.
- **Mitochondria** — oval organelles bound by a double membrane with inner folds enclosing important metabolic enzymes; they produce nearly all (95%) of the ATP and energy required by the cell.
- **Lysosomes** — vesicles that contain strong digestive enzymes; lysosomes are responsible for the intracellular removal of damaged organelles or pathogens.
- **Peroxisomes** — very small, membrane-bound organelles which contain a large variety of enzymes that perform a diverse set of metabolic functions.
- **Golgi apparatus** — stacks of flattened membranes containing chambers; they synthesize, store, alter, and package secretory products.
- **Centrioles** — there are two centrioles, aligned at right angles, each composed of 9 microtubule triplets; they organize specific fibers of chromosomes during cell division, which move the chromosomes.
- **Cilia** — thread-like projections of the outer layer of the cell membrane, which serve to move substances over the cell surface.

## Cell Components Most Susceptible to Xenobiotics

While all components of the cell can be damaged by xenobiotics or body products produced in reaction to the xenobiotics, the components most likely to be involved in cellular damage are the cell membrane, nucleus, ribosomes, peroxisomes, lysosomes, and mitochondria.

Agents that can lead to changes in the permeability of the membrane and the structural integrity of a cell can damage **cell membranes**. The movement of substances through cell membranes is precisely controlled to maintain homeostasis of the cell. Changes in toxin-induced cell membrane permeability may directly cause cell death or make it more susceptible to the entrance of the toxin or to other toxins that follow. The effects in this case may be cell death, altered cell function, or uncontrolled cell division (neoplasia).

**Nuclei** contain the genetic material of the cell (chromosomes or DNA). Xenobiotics can damage the **nucleus**, which in many cases lead to cell death, by preventing its ability to divide. In other cases, the genetic makeup of the cell may be altered so that the cell loses normal controls that regulate division. That is, it continues to divide and become a neoplasm. How this happens is described in the [Cancer section](#) of ToxTutor.

**Ribosomes** use information provided by the nuclear DNA to manufacture proteins. Cells differ in the type of protein they manufacture. For example, the ribosomes of liver cells manufacture blood proteins whereas the ribosomes of fat cells manufacture triglycerides. Ribosomes contain RNA, structurally similar to DNA. Agents capable of damaging DNA may also damage RNA. Thus, toxic damage to ribosomes can interfere with protein synthesis. In the case of damage to liver cell ribosomes, a decrease in blood albumin may result with impairment in the immune system and blood transport.

**Lysosomes** contain digestive enzymes that normally function in the defense against disease. They can break down bacteria and other materials to produce sugars and amino acids. When xenobiotics damage lysosomes, the enzymes can be released into the cytoplasm where they can rapidly destroy the proteins in the other organelles, a process known as **autolysis**. In some hereditary diseases, the lysosomes of an individual may lack a specific lysosomal enzyme. This can cause a buildup of cellular debris and waste products that is normally disposed of by the lysosomes. In such diseases, known as lysosomal storage diseases, vital cells (such as in heart and brain) may not function normally resulting in the death of the diseased person.

**Peroxisomes**, which are smaller than lysosomes, also contain enzymes. Peroxisomes normally absorb and neutralize certain toxins such as hydrogen peroxide (H<sub>2</sub>O<sub>2</sub>) and alcohol. Liver cells contain considerable peroxisomes that remove and neutralize toxins absorbed from the intestinal tract. Some xenobiotics can stimulate certain cells (especially liver) to increase the number and activity of peroxisomes. This, in turn, can stimulate the cell to divide. The xenobiotics that induce the increase in peroxisomes are known as "peroxisome proliferators." Their role in cancer causation are discussed in the [Cancer section](#) of ToxTutor.

**Mitochondria** provide the energy for a cell (required for survival), by a process involving ATP synthesis. If a xenobiotic interferes with this process, the death of the cell will rapidly ensue. Many xenobiotics are mitochondrial poisons.

- Examples of poisons that cause cell death by interfering with mitochondria include cyanide, hydrogen sulfide, cocaine, DDT, and carbon tetrachloride.

### Knowledge Check

1) There are several different types of cellular organelles. The very small structures (*fixed to the endoplasmic reticulum or free within the cytoplasm*) that consist of RNA and proteins, and function in protein synthesis, are:

- a) Nucleus
- b) Peroxisomes
- c) Lysosomes
- d) Ribosomes

**Answer**

Legally enforceable acceptable exposure levels or controls

Exposure standards are legally enforceable acceptable exposure levels or controls resulting from Congressional or Executive mandate.

2) The organelle that produces nearly all (95%) of the energy required by the cell is the:

- a) Nucleolus
- b) Golgi apparatus
- c) Mitochondria
- d) Centioles

**Answer**

Recommended maximum exposure levels which are voluntary and not legally enforceable

Exposure guidelines are recommended maximum exposure levels that are voluntary and not legally enforceable.

---

This page titled [8.5: Cells](#) is shared under a [CC BY-NC 4.0](#) license and was authored, remixed, and/or curated by [ToxMSDT Online component](#) via [source content](#) that was edited to the style and standards of the LibreTexts platform.

## 8.6: Chemicals

# Chemicals

Most toxic effects are initiated by chemical interactions in which a foreign chemical or physical agent interferes with or damages normal chemicals of the body. This interaction results in a body chemical being unable to carry out its function in maintaining homeostasis.

There are many ways this can happen; for example:

- Interference with absorption or disposition of an essential nutrient.
- Interference with nerve transmission (see [Neurotoxicity](#)).
- Damage to a cell organelle preventing its functioning (see [Cell Damage and Tissue Repair](#)).

## Types of Physiological Chemicals

There are three categories of chemicals normally functioning in the body:

1. **Elements** — substances made up of only one atom; for example:
  - Hydrogen
  - Calcium
  - Singlet oxygen (O)
2. **Inorganic compounds** — simple molecules that usually consist of one or two different elements; for example:
  - Water (H<sub>2</sub>O)
  - Carbon dioxide (CO<sub>2</sub>)
  - Bimolecular oxygen (O<sub>2</sub>)
  - Sodium chloride (NaCl)
3. **Organic compounds** — substances that contain covalently-bonded carbon and hydrogen and often other elements; for example:
  - Sugars
  - Lipids
  - Amino acids
  - Proteins

## Elements

**Elements** are components of all chemical compounds. Of the 92 naturally occurring elements, only 20 are normally found in the body. Seven of these, carbon, oxygen, hydrogen, calcium, nitrogen, phosphorus, and sulfur make up approximately 99% of the human body weight. In most cases, the elements are components of inorganic or organic compounds. However, in a few cases the actual elements may enter into chemical reactions in the body, such as oxygen during cell respiration, sodium in neurotransmission, and arsenic and lead in impaired mitochondrial metabolism.

## Inorganic Compounds

**Inorganic compounds** are important in the body and responsible for many simple functions. The major inorganic compounds are water (H<sub>2</sub>O), bimolecular oxygen (O<sub>2</sub>), carbon dioxide (CO<sub>2</sub>), and some acids, bases, and salts. The body is composed of 60–75% water. Oxygen is required by all cells for cellular metabolism and circulating blood must be well oxygenated for maintenance of life. Carbon dioxide is a waste product of cells and must be eliminated or a serious change in pH can occur, known as acidosis. A balance in acids, bases, and salts must be maintained to assure homeostasis of blood pH and electrolyte balance.



## Organic Compounds

**Organic compounds** are involved in nearly all biochemical activities related to normal cellular metabolism and function. The mechanisms by which xenobiotics cause cellular and biochemical toxicity are predominantly related to changes to organic compounds. The main feature that differentiates organic compounds from inorganic compounds is that organic compounds always contain carbon. Most organic compounds are also relatively large molecules. There are five major categories of organic compounds involved in normal physiology of the body:

1. Carbohydrates
2. Lipids
3. Proteins
4. Nucleic acids
5. High-energy compounds

Figure 8.6.1. Organic compounds are involved in numerous structures and functions of biochemical processes in the body (Image Source: NLM)

## Carbohydrates

Most **carbohydrates** serve as sources of energy for the body. They are converted to glucose, which in turn is used by the cells in cellular respiration. Other carbohydrates become incorporated as structural components of genetic macromolecules.

- For example, deoxyribose is part of DNA, the genetic material of chromosomes, and ribose is part of RNA, which regulates protein synthesis.

## Lipids

**Lipids** are essential substances of all cells and serve as a major energy reserve. They may be stored as fatty acids or as triglycerides. Other types of lipids are the steroids and phospholipids.

- Cholesterol is a lipid that is a component of cell membranes and is used to produce sex hormones such as testosterone and estrogen.
- Phospholipids serve as the main components of the phospholipid bilayer cell membrane.

## Proteins

The most diverse and abundant of organic compounds in the body is the group of **proteins**. There are about 100,000 different kinds of proteins, which account for about 20% of the body weight. The building blocks for proteins are the 20 amino acids, which contain carbon, hydrogen, oxygen, nitrogen, and sometimes sulfur. Most protein molecules are large and consist of 50–1000 amino acids bonded together in a very precise structural arrangement. Even the slightest change in the protein molecule alters its function.

**Proteins** perform a large variety of important functions. Some proteins have a structural function such as the protein pores in cell membranes, keratin in skin and hair, collagen in ligaments and tendons, and myosin in muscles.

- Hemoglobin and albumin are proteins that carry oxygen and nutrients in the circulating blood.
- Antibodies and hormones are proteins.

A particularly important group of proteins are the enzymes.

**Enzymes**, which are catalysts, are compounds that accelerate chemical reactions, without themselves being permanently changed. Each enzyme is specific in that it will catalyze only one type of reaction. Enzymes are vulnerable to damage by xenobiotics and many toxic reactions occur by changing the shape of the enzyme ("denaturation") or by inhibiting the enzyme ("inhibition").

## Nucleic Acids

**Nucleic acids** are large organic compounds that store and process information at the molecular level inside virtually all body cells. Three types of nucleic acids are present:

- Deoxyribonucleic acid (DNA)
- Ribonucleic acid (RNA)
- Adenosine triphosphate (ATP)

Nucleic acids are very large molecules composed of smaller units known as nucleotides. A nucleotide consists of a pentose sugar, a phosphate group, and four nitrogenous bases. The sugar in DNA is deoxyribose while the bases are adenine, guanine, cytosine, and thymine. RNA consists of the sugar, ribose, plus the four bases adenine, guanine, cytosine, and uracil. These two types of molecules are known as the molecules of life. For without them, cells could not reproduce and animal reproduction would not occur.

DNA is in the nucleus and makes up the chromosomes of cells. It is the genetic code for hereditary characteristics. RNA is located in the cytoplasm of cells and regulates protein synthesis, using information provided by the DNA. Some toxic agents can damage the DNA causing a mutation, which can lead to the death of the cell, cancer, birth defects, and hereditary changes in offspring. Damage to the RNA causes impaired protein synthesis, responsible for many types of diseases. Figure 2 shows the structure of DNA and RNA. Note that DNA is double-stranded and known as the double helix. RNA is a single strand of nucleotides.

Figure 8.6.2 Structures of DNA and RNA

(Image Source: Adapted from iStock Photos, ©)

## High-Energy Compounds

**Adenosine triphosphate (ATP)** is the most important high-energy compound. It is a specialized nucleotide located in the cytoplasm of cells that serves as a source of cellular energy. ATP contains adenine (amino acid base), ribose (sugar), and three phosphate groups. ATP is created from adenine diphosphate using the energy released during glucose metabolism. One of the phosphates in ATP can later be released along with energy from the broken bond induced by a cellular enzyme.

### Knowledge Check

1) A substance in the body that contains covalently-bonded carbon and hydrogen is an:

- a) Organic compound
- b) Inorganic compound
- c) Element

#### Answer

Organic compound

Organic compounds contain covalently-bonded carbon and hydrogen and often other elements. For example, sugars, lipids, amino acids, and proteins are organic compounds.

2) The nucleic acid located in the nucleus, which makes up the chromosomes of cells, is:

- a) ATP
- b) RNA
- c) DNA

#### Answer

DNA

DNA is in the nucleus and makes up the chromosomes of cells. It is the genetic code for hereditary characteristics.

This page titled [8.6: Chemicals](#) is shared under a [CC BY-NC 4.0](#) license and was authored, remixed, and/or curated by [ToxMSDT Online component](#) via [source content](#) that was edited to the style and standards of the LibreTexts platform.

## CHAPTER OVERVIEW

### Section 9: Introduction to Toxicokinetics

## Learning Objectives

After completing this lesson, you will be able to:

- Define toxicokinetics.
- Summarize the four inter-related processes of toxicokinetics.
- Identify examples of transporter proteins and their role in toxicokinetics.

## In this section...

Topics include:

[9.1: What is Toxicokinetics](#)

## What We've Covered

This section made the following main points:

- Toxicokinetics is essentially the study of how a substance enters the body and what happens to it inside the body.
  - The term "disposition" is often used in place of toxicokinetics to describe how the body disposes of a xenobiotic over time.
- The four inter-related processes of toxicokinetics are:
  1. Absorption — the substance enters the body.
  2. Distribution — the substance moves from the site of entry to other areas of the body.
  3. Biotransformation — the substance is transformed into new chemicals (metabolites).
  4. Excretion — the substance or its metabolites leave the body.
- The disposition of a toxicant and its biological reactivity are the factors that determine the severity of toxicity when a xenobiotic enters the body.

---

This page titled [Section 9: Introduction to Toxicokinetics](#) is shared under a [CC BY-NC 4.0](#) license and was authored, remixed, and/or curated by [ToxMSDT Online component](#) via [source content](#) that was edited to the style and standards of the LibreTexts platform.

## 9.1: What is Toxicokinetics

# What is Toxicokinetics?

## Toxicokinetics Defined

**Toxicokinetics** is essentially the study of "how a substance gets into the body and what happens to it in the body." Before this term was used, the study of the kinetics (movement) of chemicals was originally conducted with pharmaceuticals and the term pharmacokinetics became commonly used. Similarly, toxicology studies were initially conducted with drugs. Toxicokinetics deals with what the body does with a drug when given a relatively high dose relative to the therapeutic dose. Read more about [differences between pharmacokinetics and toxicokinetics](#).

## Processes

Four processes are involved in toxicokinetics:

1. **Absorption** — the substance enters the body.
2. **Distribution** — the substance moves from the site of entry to other areas of the body.
3. **Biotransformation** — the body changes (transforms) the substance into new chemicals (metabolites).
4. **Excretion** — the substance or its metabolites leave the body.

The science of toxicology has evolved to include environmental and occupational chemicals as well as drugs. Toxicokinetics is thus the appropriate term for the study of the kinetics of all substances at toxic dose/exposure levels.

Frequently the terms toxicokinetics, pharmacokinetics, or disposition have the same meaning. Disposition is often used in place of toxicokinetics to describe the movement of chemicals through the body over the course of time, that is, how the body disposes of a xenobiotic.

Figure 9.1.1 Processes of toxicokinetics  
(Image Source: Adapted from iStock Photos, ©)

## Factors Determining the Severity of Toxicity

The disposition of a toxicant and its biological reactivity are the factors that determine the severity of toxicity that results when a xenobiotic enters the body. The most important aspects of disposition include:

- **Duration and concentration** of a substance at the portal of entry.
- **Rate and amount** of the substance that can be absorbed.
- **Distribution** in the body and **concentration** of the substance at specific body sites.
- **Efficiency** of biotransformation and nature of the metabolites.
- **Ability** of the substance or its metabolites **to pass through cell membranes** and come into contact with specific cell components (for example, DNA).
- **Amount and duration of storage** of the substance (or its metabolites) in body tissues.
- **Rate and sites of excretion** of the substance.
- **Age and health status** of the person exposed.

Here are some examples of how toxicokinetics of a substance can influence its toxicity:

- **Absorption** — A highly toxic substance that is poorly absorbed may be no more hazardous than a substance of low toxicity that is highly absorbed.
- **Biotransformation** — Two substances with equal toxicity and absorption may differ in how hazardous they are depending on the nature of their biotransformation. A substance that is biotransformed into a more toxic metabolite (bioactivated) is a greater

hazard than a substance that is biotransformed into a less toxic metabolite (detoxified).

## Inter-Related Processes of Absorption, Distribution, Biotransformation, and Elimination

Absorption, distribution, biotransformation, and elimination are inter-related processes as illustrated in Figure 2 below. After the substance is absorbed, it is distributed through the blood, lymph circulation, and extracellular fluids into organs or other storage sites and may be metabolized. Then, the substance or its metabolites are eliminated through the body's waste products.

Figure (PageIndex{2}). Absorption, Distribution, Metabolism, and Elimination  
(Image Source: NLM)

## What are Transporters?

Transporters, also called transporter proteins, play an important role in the processes of absorption, distribution, metabolism, and elimination (ADME). They are important to pharmacological, toxicological, clinical, and physiological applications. For example:

- In the **liver** — transmembrane transporters, together with drug metabolizing enzymes, are important in drug metabolism and drug clearance by the liver. Xenobiotics, endogenous metabolites, bile salts, and cytokines affect the levels (or "expression") of these transporters in the liver. Adverse reactions in the liver to a xenobiotic such as a drug could be caused by genetic or disease-induced variations of transporter expression or drug-drug interactions at the level of these transporters.
- In the **kidneys** — renal proximal tubules are targets for toxicity partly because of the expression of transporters that mediate the secretion and reabsorption of xenobiotics. Changes in transporter expression and/or function could enhance the accumulation of toxicants and make the kidneys more susceptible to injury, for example, when xenobiotic uptake by carrier proteins is increased or the efflux of toxicants and their metabolites is reduced. The list of nephrotoxic chemicals is a long one and includes:
  - Environmental contaminants such as some hydrocarbon solvents, some heavy metals, and the fungal toxin ochratoxin.
  - Some antibiotics.
  - Some antiviral drugs.
  - Some chemotherapeutic drugs.

The competition of xenobiotics for transporter-related excretion and genetic polymorphisms affecting transporter function affect the likelihood of nephrotoxicity.

Because of concerns that such changes to transporter expression and function can adversely affect clinical outcomes and physiological regulation, increased drug transporter activity is important to study and understand. There is clinical and laboratory research including *in vitro*, *ex vivo*, and *in vivo* studies that shows how powerful drug-drug interactions can be.

For example, drugs might compete with each other for binding to a transporter, which can lead to changes in serum and tissue drug levels and possible side effects.

- This is one possible explanation for the rare occurrence of potentially severe toxicity when the drug methotrexate and nonsteroidal anti-inflammatory drugs are given at the same time.
- The drug probenecid, which competitively inhibits some transporters, has been used to increase the half-life of antibiotics such as penicillin and antiviral drugs and improve their therapeutic value.

## Pharmacokinetics and Toxicokinetics: Now and in the Future

Current research priorities suggest that we can anticipate important strides in the following areas of pharmacokinetics and toxicokinetics:

- An increased understanding of human variability of pharmacokinetics and pharmacodynamics in the population.
- Further exploration of mode of action hypotheses (**MoA**).

- Is a MoA the same as a MOA? No. A **mode of action (MoA)** describes a functional or anatomical change, at the cellular level, resulting from exposure to a substance. A **mechanism of action (MOA)** describes changes at the molecular level.
- Further application of biological modeling in the risk assessment of individual chemicals and chemical mixtures.
- Further identification and discussion of uncertainties in the modeling process.
- Further use of "Reverse Toxicokinetics," also called "**IVIVE**" (***In vitro to in vivo extrapolation***). IVIVE *in vitro* data to estimate exposures that could be associated with adverse effects *in vivo*.

---

This page titled [9.1: What is Toxicokinetics](#) is shared under a [CC BY-NC 4.0](#) license and was authored, remixed, and/or curated by [ToxMSDT Online component](#) via [source content](#) that was edited to the style and standards of the LibreTexts platform.

## Index

Your page has been created!

Remove this content and add your own.

### ▮ Edit page

Click the Edit page button in your user bar. You will see a suggested structure for your content. Add your content and hit Save.

### Tips:

#### ▮ Drag and drop

Drag one or more image files from your computer and drop them onto your browser window to add them to your page.

#### ▮ Classifications

Tags are used to link pages to one another along common themes. Tags are also used as markers for

the dynamic organization of content in the CXone Expert framework.

#### ▮ Working with templates

CXone Expert [templates](#) help guide and organize your documentation, making it flow easier and more uniformly. Edit existing templates or create your own.

▮ [Visit for all help topics.](#)



## Glossary

### A

#### Absorbed Dose

The amount of a substance that actually enters the body, usually expressed as milligrams of substance per kilogram of body weight (*mg/kg*).

#### Absorption

The process whereby a substance moves from outside the body into the body.

#### Acceptable Daily Intake (ADI)

The amount of a chemical to which a person can be exposed each day over a long period of time (*usually lifetime*) without suffering harmful effects.

#### Acetylcholine

An important chemical in the body having physiological functions, including the neurotransmission of electrical impulses across synapses of nerve endings.

#### Acetylcholinesterase

An enzyme present in nervous tissue, muscle, and red blood cells that catalyzes the hydrolysis of acetylcholine to choline and acetic acid.

#### Acetylcholinesterase Inhibitors

Chemicals that inhibit the enzyme acetylcholinesterase at neural synapses. This prevents the acetylcholinesterase from stopping the action of acetylcholine and allows for continued stimulation of the effector. The result is spasms and paralysis, which can cause paralysis and death. Some important

acetylcholinesterase inhibitors are organophosphate pesticides, carbamates, and some chemical warfare agents.

#### ACGIH®

Formerly called American Conference of Governmental Industrial Hygienists. ACGIH is a professional society for industrial hygienists that recommends safety and health guidelines.

#### Acid

A substance with one or more hydrogen atoms that are readily replaceable by electropositive atoms. It is a donator of protons. In aqueous solution, it will undergo dissociation with the formation of hydrogen ions. It has a pH of less than 7.0.

#### Action potential

A conducted change in the membrane potential of cells, initiated by an alteration of the membrane permeability to sodium ions, and subsequent propagation of an electrical impulse down an axon. Same as nerve impulse.

#### Active Transport

The movement of a substance across a membrane requiring energy. The substance moves against a concentration gradient, from a less concentrated region to a more concentrated region.

#### Acute Effect

An effect that occurs almost immediately (*seconds/minutes/hours/days*) after a single or brief exposure to a toxic agent. Generally, acute effects will be evident within 14 days.

#### Adenosine triphosphate (ATP)

An important high-energy compound located in the cytoplasm of cells, which serves as a source of cellular energy.

#### ADI

*see* Acceptable Daily Intake

#### Adsorption

The process of attracting and holding a substance to a surface. For example, a substance may adsorb onto a soil particle.

#### Aerosols

Airborne particulate which may be solids or liquid droplets.

#### Afferent nerve

A nerve that relays sensory information to the CNS.

#### Albumin

A simple protein soluble in water and distributed throughout body tissues. It is the most abundant plasma protein.

#### Allergy

An immune hypersensitivity reaction of body tissues to allergens that can affect the skin (*urticaria*), respiratory tract (*asthma*), and gastrointestinal tract (*vomiting and nausea*) or produce a systemic circulatory response (*anaphylactic response*).

#### Alveoli

The air sacs at the ends of the tracheobronchial tree in which gases are exchanged between inhaled air and the pulmonary capillary blood.

#### Ames Test

A test for mutagenesis using the bacterium *Salmonella typhimurium*.

## Amyotrophic Lateral Sclerosis

A disease in which the myelin around nerves is lost causing paralysis and loss of sensory and motor function. Same as Lou Gehrig's disease.

## Anaplasia

An alteration of cells from normal appearance to poorly-differentiated or undifferentiated morphology. They have irregular nuclei and cell structure with numerous mitotic figures. Anaplasia is frequently associated with malignancies and serves as one criterion for grading the aggressiveness of a cancer.

## Anemia

A condition in which there is reduced or impaired red blood cells or hemoglobin resulting in an inadequate capacity of the blood to transport oxygen to body tissues.

## Aneuploidy

Any deviation from an exact multiple of the haploid number of chromosomes. This may involve missing or extra chromosomes or parts of chromosomes.

## Anoxia

An insufficient (*below normal*) supply of oxygen in the body tissues.

## Antagonism

An interaction between two chemicals in which one decreases the expected toxic effect of the other.

## Antibody

An antibody is a protein molecule (*immunoglobulin with a unique amino acid sequence*) that only interacts with a specific or closely related foreign substances (*antigen*). The antibody is

induced (*a response of the immune system*) as a result of prior exposure to the antigen.

## Anticholinergic Effects

Neurological effects resulting from the blockage of acetylcholine, which transmits impulses across nerve junctions.

## Antidote

A remedy for counteracting a poison.

## Anxiety

A feeling of apprehension, uncertainty, and fear without apparent stimulus, and associated with tachycardia, sweating and tremors.

## Apoptosis

Individual or single cell death by a process of self-destruction of the cell nucleus. In apoptosis, dying cells are not contiguous but are scattered throughout a tissue. Often referred to as "programmed cell death."

## Aqueous

Of a watery nature. Prepared with water.

## Asphyxiant

A substance, which in high concentrations in air, replaces or reduces the oxygen level such that a person inhaling the air mixture suffers hypoxia.

## Astrocyte

A type of glial cell in the CNS. They are big cells that maintain the blood-brain barrier and provide rigidity to the brain structure.

## Atrophy

A decrease in the size of cells. If a

sufficient number of cells are involved, the tissue or organ may also decrease in size.

## Atropine

An anticholinergic drug that blocks acetylcholine receptors.

## ATSDR

Agency for Toxic Substances and Disease Registry, a US federal agency responsible for emergency response to chemical spills and assessment of health effects of hazardous waste sites.

## Autoimmunity

An immune response in which the constituents of the body's own cells are seen as foreign, resulting in hypersensitivity to its own tissues.

## Autonomic Nervous System

The part of the nervous system involved in the unconscious regulation of visceral functions by transmitting motor information to smooth muscles, cardiac muscle, and various glands.

## Axon

The elongation of a neuron that conducts an action potential. It may extend long distances from one part of the body to another.

## B

## Base

A substance that dissociates in water to yield a hydroxyl ion. A donor of electrons.

## Batrachotoxin

A potent neurotoxin of some South American frogs that has been used as

arrow poisons.

## Benign tumor

A tumor that grows only at the site of origin and does not invade adjacent tissues or metastasize. It is generally treatable.

## Bias

Systematic error that may be introduced in sampling by selecting or encouraging one outcome over another.

## Biliary

Pertaining to bile, an excretion produced by the liver, stored in the gall bladder, and released into the small intestine.

## Bioactivation

The metabolic process whereby a parent substance is chemically changed to a daughter substance with enhanced biological activity.

## Bioassay

A laboratory study used to determine the ability of a substance to produce a particular biological effect.

## Bioavailability

The physical and/or biological state of a substance rendering it capable of being absorbed into the body.

## Biological Half-Life

The time required to eliminate one-half the quantity of a substance from the body.

## Biotransformation

Conversion of a chemical from one form to another by a biological organism.

## Blood-Brain Barrier

The anatomical barrier that isolates the

CNS from the general circulation. The cell responsible is the astrocyte, which forms, layers around capillaries and regulates diffusion of substances from the blood circulation to the neurons.

## Body Burden

The concentration of a substance that has accumulated in the body.

## Bone Marrow

The tissue within the internal open space of bones (*e.g., shaft of long bones*) in which the blood-forming elements exist.

## Botulinum toxin

A potent neurotoxin that blocks the release of acetylcholine at neuromuscular junctions.

## Bronchioles

The very small branches of the tracheobronchial tree of the respiratory tract which terminate in the alveoli.

## C

## Cancer

An uncontrolled growth of abnormal cells, creating a tumor that can invade surrounding tissues and may spread (*metastasize*) to distant organs.

## Cancer Slope Factor

A key risk assessment parameter derived by the EPA. It is an estimate of the probability that an individual will develop cancer if exposed to a specified amount of chemical (*mg/kg*) every day for a lifetime.

## Capillaries

The very small blood vessels that take blood from small arteries to small veins.

## Carbohydrates

Organic compounds that serve as sources of energy for the body. They are converted to glucose, which in turn is used by the cells in cell respiration.

## Carcinogen

A compound that is capable of causing cancer.

## Carcinogenesis

A general term for production of any type of tumor.

## Carcinogenic

The ability of a substance to cause cancer.

## Carcinogenicity

The complex process whereby normal body cells are transformed into cancer cells.

## Carcinoma

A malignant tumor arising in epithelium. It is the most common form of cancer and usually spreads via the lymphatic system.

## Cardiovascular System

The organ system that transports oxygen and nutrients to tissues and removes waste products. The main components are the heart, blood, and blood vessels.

## Case-Control Study

A type of study in which subjects that have a disease or outcome [cases] are compared to subjects that do not have the disease or outcome [controls]. In toxicology, a case-control study compares the exposure histories of humans who have a particular toxic effect with that of normal individuals

## Catalyst

A substance that accelerates a reaction.

## Cell

The smallest living unit in the body.

## Cell membrane

The membrane composed of phospholipids, proteins, and cholesterol that form the outer boundary of a cell and regulates the movement of substances into and out of the cell.

## Cell Proliferation

The process by which cells undergo mitosis and divide into similar cells.

## Cell Transformation

The change of a cell from one form to another. The term is generally used to denote the change from normal to malignant.

## Cellular Swelling

A pathologic condition of a cell that is associated with hypertrophy. It is due to cellular hypoxia, which damages the sodium-potassium membrane pump. This in turn changes the intracellular electrolyte balance causing an influx of fluids into the cell and resultant swelling.

## Centrioles

Organelles composed of nine microtubule triplets that organize specific fibers of chromosomes and move the chromosomes during cell division. There are two centrioles, aligned at right angles to each other.

## Cerebellum

A posterior portion of the brain that is responsible for voluntary and involuntary motor activities based on memory and sensory input.

## Cerebrum

The largest portion of the brain that controls thought processes, intelligence, memory, sensations, and complex motor functions.

## Chemicals

Atoms or molecules that are the building blocks of all matter.

## Cholestasis

A liver condition in which excretion of bile salts via the bile duct is inhibited, resulting in bile salts backing up into liver cells.

## Chromosome

One of a group of structures that form in the nucleus of a cell during cell division. Chromosomes bear DNA and carry an organism's genetic code.

## Chromosome

### Aberration

Changes in chromosome structure.

## Chronic Effect

An effect that either shows up a long time after an exposure (*the latency period*) or an effect that results from a long-term (*chronic*) exposure.

## Cilia

Thread-like projections of the outer layer of the cell membrane, which serve to move substances over the cell surface.

## Cirrhosis

A chronic condition of the liver in which liver cells are replaced by fibrous cells.

## CNS

The central nervous system consisting of the brain and spinal cord.

## Compartment

As used in toxicokinetics, compartment is a hypothetical volume of a body system wherein a chemical acts homogeneously in transport and transformation. The body is composed of organs, tissues, cells, cell organelles, and fluids, any one or several of which may be referred to as a compartment.

## Concentration

### Gradient

The relative amounts of a substance on either side of a membrane. Diffusion occurs from a region of high concentration to a region of low concentration.

## Cohort Study

A type of study in which a cohort (group) of individuals who have been exposed to a substance or had treatment for a disease and a cohort without that exposure or that treatment are followed over time to compare disease occurrence. In toxicology, a cohort (*group*) of individuals with exposure to a chemical and a cohort without exposure are followed over time to compare disease occurrence.

## Conjugation

A metabolic process in which chemical groups are attached to foreign substances in the body, usually making the conjugated chemical more water soluble and easier to eliminate from the body.

## Conjugate

A metabolite that results from the joining of a Phase II molecule with a xenobiotic. It is generally more water soluble than the original substance.

## Connective Tissue

One of the four tissues of the body. It is specialized to provide support and hold the body tissues together (*i.e.*, *they connect*). It contains more intercellular substances than the other tissues. Bones, cartilage, and fat are types of connective tissue. The blood and lymph vessels are immersed in the connective tissue media of the body.

## Control Group

A group of animals or humans in a study that are treated the same as the exposed groups but without receiving the specific exposure.

Cornea The transparent front surface of the eye.

## Corrosion

Direct chemical action that results in irreversible damage at the site of contact. It is manifested by ulceration, necrosis, and scar formation.

## Covalent Bond

The joining together of atoms that results from sharing electrons.

## CPSC

Consumer Product Safety Commission. It is a US federal agency responsible for protecting the public from toxins and other hazards present in consumer products.

## Cytochrome P-450

An iron-protein complex with a maximum absorbance of visible light at 450 nm that functions as a nonspecific enzyme system during Phase I biotransformation reactions.

## Cytoplasm

The fluid matrix of a cell exclusive of the nucleus. Cytoplasm consists of a

continuous aqueous solution (cytosol) and the organelles and inclusions suspended in it. This is the site of most chemical activities within the cell.

## Cytosol

The liquid medium of the cytoplasm, that is, cytoplasm without the organelles and non-membranous insoluble components.

## D

## Demyelination

The loss of the myelin sheath (*insulation*) around a nerve.

## Dendrites

Sensory processes of a neuron that are specialized to receive incoming information and send it to the neuron cell body.

## Dermal Toxicity

Toxicity of the skin, which can range from mild irritation to corrosivity, hypersensitivity, and skin cancer. It can result from direct contact or internal distribution of the xenobiotic to the skin.

## Deoxyribonucleic

## Acid (DNA)

A nucleic acid known as the molecule of life that makes up the chromosomes. It is composed of a chain of nucleotides containing the sugar deoxyribose and the nitrogen bases, adenine, guanine, cytosine, and thymine wound in a double helix and held together by weak bonds between complementary nitrogen base pairs.

## Depression

A clinical psychiatric condition in which a person has a dejected mood, psychomotor retardation, insomnia and

weight loss, sometimes associated with guilt feelings and often with delusional preoccupations.

## Detoxification

A metabolic process whereby a parent substance is changed to a daughter product (*metabolite*) that has less toxicity.

## Diencephalon

A portion of the brain that contains the thalamus, hypothalamus, and pituitary gland. It relays and processes sensory information; control of emotions, autonomic functions, and hormone production.

## Diffusion

The spontaneous movement of a substance from a high concentration gradient to a lower concentration gradient.

## Digestive System

The organ system that functions to process foods that are ingested, absorb nutrients into body, and provide metabolized nutrients to the body cells. Consists of the mouth, salivary glands, esophagus, stomach, intestinal tract, liver, and pancreas.

## Disease

A malfunction of any component of the body that can result in an abnormal and undesirable physiological or anatomical change.

## Disposition

The term used to describe the kinetics of a substance in the body. It encompasses absorption, distribution, metabolism, and elimination of a chemical.

## Distal

Away from a point of reference. As used



in medicine, something distal is farther away from the main body. For example, the foot is distal to the knee.

## Distribution

Movement of a substance from the site of entry to other parts of the body.

## DNA (Deoxyribonucleic acid)

A nucleic acid known as the molecule of life that makes up the chromosomes. It is composed of a chain of nucleotides containing the sugar deoxyribose and the nitrogen bases, adenine, guanine, cytosine, and thymine wound in a double helix and held together by weak bonds between complementary nitrogen base pairs.

## Dosage

The determination of quantity of a substance received, which incorporates the size, frequency, and duration of doses (e.g., 10 mg every 8 hours for 5 days).

## Dose

The amount of a substance received at one time. Dose is usually expressed as administered or absorbed dose (e.g., milligrams material/kilogram of body weight).

## Dose-Response Assessment

The relation between dose levels and associated effects.

## Dose-Response Curve

A graphical representation of the quantitative relationship between doses of a substance and specific biological effects.

## Draize Test

The test for eye irritation in which the test substance is placed on the eyes of white rabbits and observed for 72 hours.

## Dying-back

## Neuropathy

A neurological condition in which axons begin to die at the very distal end of the axon with necrosis slowly progressing toward the cell body.

## Dysplasia

A condition of abnormal cell change or deranged cell growth in which the cells are structurally changed in size, shape, and appearance from the original cell type.

## E

### ED50

Effective dose 50%. The estimated dose that causes some specific effect (*usually desirable*) for 50% of the population.

### ED99

Effective dose 99%. The estimated dose that causes some specific effect (*usually desirable*) for 99% of the population.

## Effector

The body site where a response occurs which counters an initial stimulus and thus attempts to maintain homeostasis.

## Efferent Nerve

A nerve that relays motor commands from the CNS to various muscles and glands.

## Edema

Retention of fluid in an organ or in the

body.

## Element

A chemical substance composed of only one atom, e.g., hydrogen, calcium, or singlet oxygen.

## Elimination

The toxicokinetic process responsible for the removal or expulsion of a substance from the body.

## Embryo

An early stage of the development of the unborn offspring in which cell differentiation proceeds rapidly along with the formation of major organs. In humans this stage occurs from about 3 weeks until 8 to 9 weeks after conception.

## Embryotoxic

The harmful effects of a substance on the developing embryo.

## Endocrine System

The organ system that regulates body functions by use of chemicals, known as hormones. Endocrine organs are the pituitary gland, parathyroid gland, thyroid gland, adrenal gland, thymus, pancreas, and gonads.

## Endocytosis

The process whereby a substance is engulfed and taken into a cell by an inward folding of the cell membrane, which detaches and moves into the cytoplasm.

## Endoplasmic Reticulum

A cell organelle, which provides an extensive network of membrane-like channels that, extends throughout the cytoplasm. It synthesizes secretory

products and is responsible for intracellular storage and transport.

## Enterohepatic circulation

Also known as enterohepatic recirculation. The cycling of a substance from the blood into the liver, then into the bile and gastrointestinal tract. This is followed by re-uptake into the blood stream from the gastrointestinal tract, possibly after chemical or enzymatic breakdown.

## Environmental Fate

The fate of a substance following its release into the environment. It includes the movement and persistence of the substance.

## Enzyme

A protein formed in living cells that acts as a catalyst for chemical reactions in cells.

## Enzyme Activation

The increase in levels of an enzyme as the result of stimulation by another chemical substance. Same as enzyme induction.

## Enzyme Inhibitor

A substance which causes a decrease in levels of an enzyme.

## Enzymes

A chemical (*protein*) that catalyzes (*accelerates*) specific biochemical reactions without themselves being permanently changed.

## EPA

Environmental Protection Agency. A US federal agency responsible for regulation of most chemicals that can enter the environment. The EPA administers the

following acts: Federal Insecticide, Fungicide, and Rodenticide Act (FIFRA), the Toxic Substances Control Act (TSCA) which was amended in June 2016 by the Frank R. Lautenberg Chemical Safety for the 21st Century Act, the Resource Conservation and Recovery Act (RCRA), the Safe Drinking Water Act (SDWA), Clean Air Act (CAA), and the Comprehensive Environmental Response, Compensation and Liabilities Act (CERCLA) (Superfund Act).

## Ependymal Cells

A type of glial cell in the CNS that produces a special fluid, known as the cerebral spinal fluid (CSF).

## Epidemiology

The study of the relative characteristics of exposed and non-exposed human populations for the purpose of detecting harmful effects.

EpidermisThe outer layer of the skin.

## Epithelial Tissue

One of the four types of tissue in the body that is specialized to protect, absorb and secrete substances, as well as detect sensations. It covers every exposed body surface, forms a barrier to the outside world, and controls absorption.

## Equilibrium

A state of balance. Opposing forces exactly counteract each other.

## Excretion

A process whereby substances (*or metabolites*) are eliminated from the body.

## Exposure

Contact with a foreign substance, usually by inhalation, ingestion, or skin contact.

## Exposure Assessment

Analysis or estimation of the intensity, frequency, and duration of human exposures to an agent.

## Exposure Dose

The amount of a substance in the environment to which a person is subjected.

## F

F0 Generation  
(written as F<sup>\*subscript\* 0</sup>)

The parent generation in a multigeneration reproduction study.

F1 Generation  
(written as F<sup>\*subscript\* 1</sup>)

The first filial generation (*offspring*) in a multigeneration reproduction study. It is produced by breeding individuals of the F0 generation.

F2 Generation  
(written as F<sup>\*subscript\* 2</sup>)

The second filial generation (*offspring*) in a multigeneration reproduction study. It is produced by breeding individuals of the F1 generation.

## Facilitated diffusion

The passage of molecules and ions across a cell membrane with the aid of a specific carrier protein. It is dependent on concentration gradient.

## Fatty Change

A toxic cellular change that occurs with severe cellular injury. The cell has become damaged and is unable to adequately metabolize fat, resulting in development of small vacuoles of fat that accumulate and become dispersed within the cytoplasm. It is usually observed in the liver.

## FDA

Food and Drug Administration. A US federal agency responsible for evaluating the safety of drugs, cosmetics, food additives, and medical devices.

## Feedback Mechanism

A part of the homeostasis in which the body regulates the degree of response to a stimulus. A negative feedback depresses the stimulus to shut off or reduce the effector response whereas a positive feedback has the effect of increasing the effector response.

## Femtogram (fg)

An extremely minute quantity,  $1 \times 10^{-15}$  gram.

## Fetus

The unborn offspring in the postembryonic period, after major structures have been outlined. In humans this occurs from 8 to 9 weeks after conception until birth.

## Fibrosis

The formation of scar tissue in an organ, generally by replacement of functional organ cells with nonfunctional fibrous tissue.

## FIFRA

Federal Insecticide, Fungicide, and Rodenticide Act. A US federal law administered by the EPA for evaluation

and registration of pesticides.

## Filtrate

A substance that has passed through a filter. As used in toxicokinetics, it usually pertains to the material that has passed through the glomerulus into the renal tubule.

## Filtration

The passage of a solvent and dissolved substance through a membrane or filter. In excretion, a portion of the plasma and dissolved materials undergo filtration through the glomerular filter (*capillary bed*).

## First-pass Effect

The biotransformation of a substance in the liver after absorption from the intestine and before it reaches the systemic circulation.

## G

### Gamma

### Aminobutyric Acid (GAMA)

A neurotransmitter of the CNS whose effects are usually inhibitory.

### Gene

The smallest subunit of a chromosome that contains a genetic message.

### Gene Mutation

A change in the DNA sequence within a gene.

### Genetic Toxicity

Toxic effects that result from damage to DNA and altered genetic expression.

## Germ Cell

Reproductive cells that give rise to sperm or ova.

## Glial cells

The supporting cells of the neural tissue. They regulate the environment around the neurons and protect against foreign invaders. They are also known as neuroglia.

## Glomerular filtration

The first step in urine formation in which blood enters the vascularized glomerulus where water and small molecules are forced by hydrostatic pressure across the glomerular filter and into the filtrate of the Bowman's capsule of the renal tubule.

## Glomerulus

The highly vascular structure in the kidney where much of the fluid portion of the blood (*serum*) is filtered and passes into the kidney tubules, carrying with it toxins and many other materials present in the serum.

## Glucuronidation

The process of adding glucuronide to a toxicant or Phase I metabolite during Phase II biotransformation.

## Glucuronide

A glycosidic compound of glucuronic acid. Generally inactive. Constitutes the major portion of some metabolites.

## Glutathione

The tripeptide glutamyl-cysteinyl-glycine. It is found in most tissue, especially the liver. It plays a major role in detoxication and cellular protection.

## Golgi Apparatus

Cell organelles composed of stacks of



flattened membranes containing chambers. They synthesize, store, alter, and package secretory products and lysosomes.

## H

### Half-Life

The time required for a concentration of a substance in a body fluid (usually blood plasma) to decrease by half.

### Hazard

The inherent adverse effect of a substance.

### Hazard Identification

Characterization of the innate adverse toxic effects of an agent.

### Hepatic Cancer

Cancer of the liver.

### Hepatic Necrosis

Death of liver cells (*hepatocytes*).

### Hepatitis

Inflammation of the liver

### Hepatotoxicity

Toxicity of the liver and associated bile duct and gall bladder.

### Hepatotoxin

A systemic poison whose target organ is the liver.

### Heritable

### Translocation Assay

A test for mutagenicity in which exposed male fruit flies (*Drosophila*) or mice are bred to non-exposed females. The offspring males (*F1 generation*) are then

bred to detect the presence of chromosomal translocations indicating this specific type of mutation.

### Herpes Simplex Virus

A virus that causes a disease marked by vesicles of the skin, usually on the lips, nares, or genitals.

### High Throughput Screening

Involves *in vitro* assays (often called High throughput assays), many of which use human proteins or cells (primary cells or cell lines). The automated methods allow for a large number of chemicals to be rapidly evaluated for a specific type of bioactivity at the molecular or cellular level. The assays can be run for a range of test chemical concentrations and produce concentration-response information representing the relationship between chemical concentration and bioactivity. For toxicity testing for human health effects, these assays primarily use human cells and focus on assessing disruptions to key biological pathways.

### Human Dose Equivalent

A calculation of the dose in humans that produces a specific effect based on the dose that produces the effect in animals. A conversion formula comparing animal to human body weight or animal to human body surface is used.

### Hydrolysis

The chemical process in which water is used to split a substance into smaller molecules. The hydrogen and hydroxyl parts of a water molecule bond to opposite locations on a chemical bond at the site where the split occurs.

### Hydrophilic

Water loving. Substance that has strong polar groups that readily interacts with water.

### Hyperplasia

An increase in the number of cells in a tissue. This generally results in an enlargement of tissue mass and organ size.

### Hypersensitivity

A state of altered immune reactivity in which the body reacts with an exaggerated response to a foreign agent.

### Hypertrophy

An increase in size of individual cells. This frequently results in an increase in the size of a tissue or organ.

### Hypoxia

A partial reduction in the oxygen concentration supplied to cells or tissues.

### IDLH

Immediately Dangerous to Life and Health. A National Institute of Occupational Safety and Health estimate for the maximum level of exposure from which a person could exit in 30 minutes without escape-impairing symptoms or irreversible health effects.

### Immunotoxicity

Toxicity of the immune system. It may take several forms: hypersensitivity (*allergy and autoimmunity*), immunodeficiency, and uncontrolled proliferation (*leukemia and lymphoma*).

### In Silico

Testing done via computer or computer simulation.

## In Vitro

Testing done in a controlled environment outside of a living organism, for example, in a test tube.

## In Vivo

Testing done using a whole living organism.

## Inhibition

A reduction in the activity of a reaction. In toxicokinetics, it normally refers to enzyme inhibition.

## Initiation Phase

The initial stage in the carcinogenesis process, which consists of the alteration of the DNA (*mutation*) of a normal cell. The initiated cell has thus developed a capacity for unregulated growth.

## Inorganic Compounds

Simple molecules that usually consist of one or two different elements. For example, water ( $H_2O$ ), carbon dioxide ( $CO_2$ ), bimolecular oxygen ( $O_2$ ), and sodium chloride ( $NaCl$ ).

## Integumentary System

The organ system that serves as a barrier to invading environmental organisms and chemicals and serves in temperature control. Organs include the skin, hair, nails, and exocrine glands.

## Interactions

Refers to measures of effects of simultaneous exposure to two or more substances. The four types of interactions are additive, antagonistic, potentiation, and synergistic.

## Interneurons

Interneurons are neurons located only in the CNS and provide connections between sensory and motor neurons. They can carry either sensory or motor impulses. They are involved in spinal reflexes, analysis of sensory input, and coordination of motor impulses. They play a major role in memory and the ability to think and learn. They are also known as association neurons.

## Interstitial fluid

The fluid in the space between cells. Same as intercellular fluid.

## Intracellular Fluid

The fluid within a cell. It is also known as the cytoplasm.

## Ionized

Separated into ions. Normally, an ionized substance will dissolve in water.

## Irritation

Local tissue reaction without involvement of an immunologic mechanism. It is a reversible inflammation.

## J

## K

## Karyorrhexis

The rupture of the cell nucleus with the disintegration of the chromatin into granules which are extruded from the cell.

## Kilogram (kg)

A measure of weight consisting of 1000 grams.

## Kinetics

Refers to turnover, movement, or rate of change of a specific factor, e.g., chemical reaction. It is commonly expressed in units of amount per unit time.

## L

## Labile Cells

Body cells that have a limited lifespan and are capable of routine division and replacement. The squamous epithelium of skin, mouth, vagina and cervix, columnar epithelium of intestinal tract, transitional epithelium of urinary tract, and hematopoietic stem cells of the bone marrow are examples of labile cells.

## Latency Period

The period of time between an exposure and onset of toxicity.

## LC0

Lethal Concentration 0%. The calculated concentration of a gas at which none of the population is expected to die.

## LC10

Lethal Concentration 10%. The calculated concentration of a gas at which 10% of the population is expected to die.

## LC50

Lethal Concentration 50%. The calculated concentration of a gas at which 50% of the population is expected to die.

## LC90

Lethal Concentration 90%. The calculated concentration of a gas at which 90% of the population is expected to die.

## LD0

Lethal Dose 0%. The estimated dose at

which none of the population is expected to die.

## LD10

Lethal Dose 10%. The estimated dose at which 10% of the population is expected to die.

## LD50

Lethal Dose 50%. The estimated dose at which 50% of the population is expected to die.

## LD90

Lethal Dose 90%. The estimated dose at which 90% of the population is expected to die.

## Lethal Injury

Damage to a cell or the body so severe that death results.

## Leukemia

Cancer of the hematopoietic system, the blood-forming organs.

## Linearized Multistage Model

A conservative quantitative cancer assessment model used by the EPA. It assumes linear extrapolation with a zero dose threshold from the upper confidence level of the lowest dose that produced cancer in an animal test or in a human epidemiology study.

## Lipid Soluble

Capable of being dissolved in fat or in solvents that dissolve fat. Usually nonionized compounds.

## Lipid

A large and diverse group of organic compounds that contain primarily carbon

and hydrogen atoms with a lesser amount of oxygen. Most lipids are insoluble in water but will readily dissolve in other lipids and in organic solvents.

## Lipids

Essential substances of all cells and a major energy reserve for the body. Lipids may be stored as fatty acids or as triglycerides.

## Lipophilic

Having an affinity for fats or lipids. A substance that is lipophilic has high lipid solubility and can penetrate cell membranes by passive diffusion.

## Lipophilicity

A term used to describe the ability of a substance to dissolve in, or associate with, fat and therefore living tissue. This usually applies to substances that are non-ionized or non-polar or have a non-polar portion. High lipid solubility usually implies low water solubility.

## LOAEL

Lowest Observed Adverse Effect Level. The lowest dose in a study in which there was an observed toxic or adverse effect.

## Lou Gehrig's Disease

A disease in which the myelin around nerves is lost causing paralysis and loss of sensory and motor function. Same as Amyotrophic Lateral Sclerosis.

## Lymphatic System

An organ system that returns tissue fluid to blood and defends against foreign organisms. Organs include the spleen, lymph nodes, thymus, and the lymphatic vessels.

## Lysosomes

Organelles that consist of vesicles that

contain strong digestive enzymes. Lysosomes are responsible for the intracellular removal of damaged organelles or pathogens.

## M

## Macrophage

Large phagocytic cells of the blood or lymph systems that can engulf particles or small organisms.

## Malignant Cell

A cancer cell that has the potential to invade surrounding tissues or spread to other areas of the body (*metastasize*).

## Malignant Tumor

A tumor that can invade surrounding tissues or metastasize to distant sites, resulting in life-threatening consequences.

## Margin of Safety (MOS)

The ratio of the dose that is just within the lethal range (*LD01*) to the dose that is 99% effective (*ED99*), *LD01/ED99*. A ratio of greater than 1 gives comfort to the physician whereas a ratio of less than 1 denotes caution.

## Mechanism of Action

The specific manner by which a substance causes a particular effect.

## Medulla Oblongata

The segment of the brain that is attached to the spinal cord. It relays sensory information to the rest of the brain and regulates autonomic function, including heart rate and respiration.

## Metabolism

The conversion of a chemical from one form to another. *Same as Biotransformation.*

## Metabolite

A chemical produced when a substance is metabolized by a biological organism.

## Metaplasia

The conversion from one type of mature cell to a different type of mature cell. It is a cellular replacement process. An example is cirrhosis of the liver.

## Metastasis

The movement of diseased cells, in particular cancer cells, from the site of origin to another location in the body.

## Metastatic Foci

Secondary tumors in an organ different from the original site of cancer development.

## mg/kg

A commonly used dose that stands for mg of a substance per kg of body weight.

## mg/kg/day

A commonly used dosage that stands for mg of a substance per kg of body weight on a daily basis.

## mg/m<sup>3</sup> (N.B. <sup>^</sup> indicates superscript)

An exposure unit used to express concentrations of particulates in the air, standing for milligrams of compound per cubic meter of air.

## Microglia

A type of glial cell. The microglia are small, mobile, phagocytic cells that function in defense against invading

organisms and xenobiotics.

## Microgram (μg)

A commonly used unit of weight consisting of 1 millionth ( $1 \times 10^{-6}$ ) of a gram. N.B. In  $10^{-6}$  <sup>^</sup> indicates superscript.

## Micronucleus Test

A test for mutagenicity in which bone marrow or peripheral blood cells are examined for the presence of micronuclei (*broken pieces of chromosomes surrounded by a nuclear membrane*).

## Microsomes

The subcellular organelles that are a part of the smooth endoplasmic reticulum.

## Midbrain

The area of the brain between the cerebrum and brain stem. It contains the centers that process auditory and visual data and generates involuntary motor responses.

## Milligram (mg)

The most commonly used unit of measure in medicine and toxicity consisting of one thousandth of a gram ( $1 \times 10^{-3}$  g). N.B. <sup>^</sup> indicates superscript.

## Minimal Risk Levels (MRLs)

A risk level calculated by the ATSDR for noncancer end points. The MRL is an estimate of daily human exposure to a substance that is likely to be without an appreciable risk of adverse effects over a specified duration of exposure. MRLs are derived for acute (*14 days or less*), intermediate (*15-364 days*), and chronic (*365 days or more*) duration exposures for either inhalation or oral routes.

## Mitochondria

Oval organelles bound by a double membrane with inner folds enclosing important metabolic enzymes. They produce nearly all (*95%*) of the ATP and energy required by the cell.

## Monooxygenase

Enzyme system (*such as cytochrome P450*) involved in the oxidation of compounds.

## Motor Neurons

The neurons that relay information from the CNS to other organs, terminating at the effectors. Motor neurons are the efferent neurons of both the somatic and autonomic nervous systems. They are also referred to as effector neurons.

## Multiple Sclerosis

A disease in which the myelin around nerves is lost causing paralysis and loss of sensory and motor function.

## Muscular System

The organ system involved with movement or locomotion and heat production. The main organs are the skeletal muscles and tendons.

## Muscular Tissue

One of the four types of tissue. It is specialized for an ability to contract. Muscle cells are elongated and referred to as muscle fibers. When a stimulus is received at one end of a muscle cell, a wave of excitation is conducted through the entire cell so that all parts contract in harmony.

## Mutagen

A substance that causes mutations (*genetic damage*).

## Mutagenesis

The process whereby a substance damages DNA and produces alterations in or loss of genes or chromosomes.

## Mutation

DNA damage resulting in genetic alterations ranging from changes in one or a few DNA base pairs (*gene mutations*) to gross changes in chromosomal structures (*chromosome aberrations*) or in chromosome number.

## Myelin

Protein layers that surround neurons and serves like insulation. Myelinated neurons usually transmit impulses at high speed, such as needed in motor neurons. Loss of myelination allows interruption of the action potential (*like leakage*) and causes a dysfunction of these cells. This can cause paralysis and loss of sensory and motor function.

## N

## Nanogram (ng)

A unit of weight consisting of 1 billionth of a gram ( $1 \times 10^{-9}$  g). N.B ^ indicates superscript

## Necrosis

The death of a cell caused by a progressive failure of essential metabolic and structural cell components, usually in the cytoplasm. Necrosis generally involves a group of contiguous cells or occurs at the tissue level.

## Neonates

Newborn animals.

## Neoplasia

A new growth of tissue with abnormal and unregulated cellular proliferation.

There are two types of neoplasia, benign and malignant. Same as a tumor.

## Neoplasm

An uncontrolled and progressive growth of cells which may be benign or malignant. *Same as Tumor.*

## Neoplastic

Pertaining to or like a neoplasm or neoplasia (*tumor*).

## Neoplastic Conversion

The second major step in the carcinogenesis process in which specific agents (*referred to as promoters*) enhance the further development of the initiated cells.

## Nephron

The functional unit of the kidney that produces urine. The primary areas are the glomerulus, convoluted tubule, and collecting duct.

NephrotoxinA systemic poison whose target is the kidney.

## Nervous System

The organ system that coordinates activities of other organ systems and responds to sensations. It is composed of the central nervous system and peripheral nervous system.

## Nervous Tissue

One of the four body tissues that is specialized so as to be capable to conduct electrical impulses and convey information from one area of the body to another. Most of the nervous tissue (98%) is located in the central nervous system, the brain, and spinal cord.

## Neural Synapse

The junction between the axon of one neuron and the dendrite of another neuron or an axon and a connection with a muscle cell (*neuromuscular junction*).

## Neuroglia

Cells of the nervous system that provide physical support for the nervous tissue, control tissue fluids around the neurons, and help defend the neurons from invading organisms and xenobiotics. Same as glial cells.

## Neurons

The functional nerve cells directly responsible for transmission of information to and from the CNS to other areas of the body.

## Neurotoxicity

Toxicity to cells of the central nervous system (*brain and spinal cord*) and the peripheral nervous system (*nerves outside the CNS*).

## Neurotoxin

A systemic poison whose target organ is the nervous system.

## Neurotransmitters

These are chemicals that move information across a synapse by diffusing across the synaptic junction, binding to receptors on the postsynaptic membrane, and stimulating generation of an action potential.

## New Drug Application (NDA)

The process by which a manufacturer of a new drug applies to the FDA for formal approval to market the drug.

NicotineA neurotoxin that binds to certain cholinergic receptors thus preventing normal neural function and stimulation.

## NIOSH

National Institute of Occupational Safety and Health. It is an institute in the U.S. Department of Health & Human Services that conducts research on health hazards in the workplace.

## NOAEL

No Observed Adverse Effect Level. The highest dose in a toxicity study at which there were no toxic or adverse effects observed.

## Non-polar

A term used to describe a molecule, which is neutral or possesses neither a positive or negative charge.

## Norepinephrine

A chemical neurotransmitter of adrenergic nerves of both the central and peripheral nervous systems. It is also produced by the adrenal medulla in response to stimulation. It is the same as noradrenaline.

## Nucleic acids

These are large organic compounds inside virtually all body cells (*RBCs is an exception*) that store and process information at the molecular level.

## Nucleolus

This is a dense region of the nucleus, which contains the RNA and DNA. It is the site for rRNA synthesis and assembly of the ribosome components.

## Nucleus

A membrane-bound part of a cell that contains nucleotides, enzymes, and nucleoproteins. The nucleus controls metabolism, protein synthesis, and the storage and processing of genetic information.

## O

### Octanol/Water

### Partition Coefficient

The ratio of the amount of a substance that will dissolve in octanol versus the amount that will dissolve in water. The higher the octanol/water partition coefficient the greater the tendency of substance to be stored in fatty tissues.

### Odds Ratio (O/R)

A statistical calculation in a case-control study involving the ratio of risk of an exposed group to that of an unexposed group. An O/R=2 means that the exposed group has twice the risk of the non-exposed group.

### Oligodendrocyte

A type of glial cell in the CNS that wraps itself around an axon to form myelin, which serves like insulation.

### Oncogene

Altered or misdirected proto-oncogene which then has the ability to transform the normal cell into a neoplastic cell. Most oncogenes differ from their proto-oncogenes by a single point mutation.

### Organ System

A group of organs that contribute to specific functions within the body.

### Organelle

A subcellular structure such as the mitochondria or nucleus of a cell.

### Organic Compound

A substance that contains covalently-bonded carbon and hydrogen and often other elements.

## Organophosphate

### Chemical

Organic chemicals that contain a phosphate group. Many are highly toxic, as they are capable of inhibition of the enzyme acetylcholinesterase at neural synapses. Many pesticides and some warfare agents are organophosphate chemicals.

### Organs

A group of tissues precisely arranged so that so they can work together to perform specific functions.

### OSHA

Occupational Safety and Health Administration. The component of the U.S. Department of Labor responsible for ensuring safe working conditions.

### Oxidation

A change in a chemical characterized by the loss of electrons. This is a primary Phase I type biotransformation reactions

## P

### p53 Gene

A normal suppressor gene that controls cell division and stimulation of repair enzymes to rebuild and restore damaged regions of the DNA. Damage or inactivation of the p53 gene is considered a contributing cause of most cancers.

### Partition Coefficient

See Octanol/water partition coefficient.

### Passive Transfer

The movement across a membrane by simple diffusion.

## Pathology



The branch of medicine that involves the functional and structural changes in tissues and organs that are caused by disease.

## PEL

Permissible Exposure Level. The standard stipulated by the Occupational Safety and Health Administration for the highest safe level of exposure to a chemical in the workplace.

## Percutaneous absorption

The transfer of a substance from the outer surface of the skin through the corneum and outer layers and into the systemic circulation.

## Peripheral Nervous System (PNS)

All nervous tissue outside the central nervous system.

## Peripheral Neuropathy

Abnormal and detrimental changes to nervous tissue outside the brain or spinal cord.

## Permanent Cells

Body cells that never divide and do not have the ability for replication even when stressed or when some cells die. Examples are neurons and muscle cells.

## Peroxisomes

Very small, membrane-bound organelles which contain a large variety of enzymes that perform a diverse set of metabolic functions.

## Phagocytosis

The engulfing of particles by certain cells of the circulatory and lymphatic systems, known as phagocytes. Phagocytosis is a primary cellular defense mechanism against foreign particles or organisms.

## Pharmacokinetics

Quantitation of the time course of chemical absorption, distribution, metabolism, and elimination.

## Pharmacology

The science that deals with the origin, nature, chemistry, effects and uses of drugs.

## Phospholipids

Molecules containing phosphates and lipids found in the cell membrane. The phosphate head is hydrophilic, whereas the lipid tail is hydrophobic.

## Physiological Adaptation

The ability of the body to adapt to changes or stresses so that the change is beneficial. Increase in muscle mass with exercise is an example of physiological adaptation.

## Picogram (pg)

A unit of weight consisting of 1 quadrillionth of a gram ( $1 \times 10^{-12}$  g). N.B ^ Indicates superscript.

## Pinocytosis

The process whereby a liquid is engulfed and taken into a cell by an inward folding of the cell membrane, which detaches and moves into the cytoplasm.

## Plasma membrane

The membrane composed of phospholipids, proteins, and cholesterol that forms the outer boundary of a cell

and regulates the movement of substances into and out of the cell. Same as cell membrane.

## Plasma

The non-cellular, fluid portion of whole blood.

## Point Mutation

A change in the DNA sequence in a gene.

## Poison

A substance capable of causing toxicity when absorbed into the body in a relatively small quantity.

## Polar

A term used to describe a molecule which is charged or ionized. Polar substances are usually the easiest for the body to excrete.

## Polyploidy

An increase in the normal number of chromosomes.

## Pons

A section of the brain that functions as a relay center and assists in somatic and visceral motor control.

## Poorly-differentiated

The change in a cell so that it has lost much of the normal appearance.

## Portal circulation

The term applied to the venous circulation draining the tissues of the gastrointestinal tract into the liver.

## Power of the Study

The statistical ability of a study to detect an effect.

## PPB

Parts per billion. The number of units of a substance in 1 billion units. PPB is a common concentration unit for dilute samples of dissolved substances or airborne substances.

## PPM

Parts per million - the number of units of a substance in a million units. PPM is a common concentration unit for dilute samples of dissolved substances or airborne substances.

## Probit Model

A risk assessment model that assumes log normal distribution for tolerances of an exposed population. It is generally considered inappropriate for the assessment of cancer risk.

## Progression Stage

The third recognized step in the carcinogenic process that is associated with the development of the initiated cell into a biologically malignant cell population.

## Proliferation

The reproduction or multiplication of similar forms, especially cells.

## Promotion Phase

The second step in the carcinogenesis process in which specific agents (*referred to as promoters*) enhance the further development of the initiated cells.

## Prospective Cohort Study

An epidemiology study in which cohorts are identified according to current exposures. The cohort is followed over time for the development of specific effects, such as cancer.

## Protein

A complex nitrogenous substance which constitutes the main building material in cells.

## Proteins

The most diverse and abundant of organic compounds in the body. There are about 100000 different kinds of proteins that perform a large variety of important functions, such as the protein pores in cell membranes, keratin in skin and hair, collagen in ligaments and tendons, myosin in muscles, and hemoglobin in RBCs. The building blocks for proteins are the 20 amino acids.

## Proto-oncogenes

Normal or good cellular genes that instruct the production of the regulatory proteins and growth factors within the cell or its membrane. Activation of a proto-oncogene can cause alteration in the normal growth and differentiation of cells, which leads to neoplasia.

## Pulmonary Fibrosis

Changes in the lining of the pulmonary alveoli in which the normal epithelial cells are replaced by fibrous tissue. Gases poorly diffuse across the fibrous tissue and thus gas exchange is drastically reduced in the lungs.

## Pyknosis

A degenerative change in a cell in which it thickens with a shrinking of the nucleus and the chromatin condenses to a solid, structureless mass or masses.

## Q

## R

## Read-across

A testing method that uses known chemical endpoints to estimate or predict unknown endpoints for chemicals similar in structure or mechanism of action.

## Receptor

The site within the body that detects or receives the stimulus, senses the change from normal, and sends signals to the control center.

## Reduction

A change in a chemical characterized by the gain of electrons. This is one of the main Phase I biotransformation reactions.

## Reference Dose (RfD)

The EPA estimate of a lifetime daily exposure level for humans that is likely to be without risk of harmful effects. RfDs are acceptable safety levels for chronic noncarcinogenic and developmental effects. The process used to derive an RfD is a modification of that used to derive an ADI.

## Relative Risk (RR)

A statistical calculation of the ratio of disease in an exposed population to that of an unexposed population.

## Reproductive System

The organ system that produces germ cells (*eggs and sperm*) and provides the environment for growth of the fetus (*women*). The main reproductive organs are the ovaries, uterus, mammary glands, testes, prostate gland, and the external genitalia.



## Reproductive Toxicity

Toxicity of the male or female reproductive system. Toxic effects can include damage to the reproductive organs or offspring.

## Respiratory System

The organ system responsible for oxygen and carbon dioxide exchange. The main organs are the lungs, trachea, larynx, nasal cavities, and pharynx.

## Respiratory Toxicity

Toxicity of the upper (*nose, pharynx, larynx, and trachea*) or lower (*bronchi, bronchioles, and lung alveoli*) respiratory system.

## Retrospective Cohort Study

An epidemiology study in which cohorts are identified according to past exposure conditions and follow-up proceeds forward in time.

## Reversible Cell Damage

A type of cellular damage in which the response of the cell to toxic injury may be transient and once the stress has been removed or the compensatory cellular changes made, it returns to full capability.

## RfD

see Reference Dose

## Ribonucleic Acid (RNA)

A nucleic acid consisting of a chain of nucleotides that contain the sugar ribose and the nitrogen bases adenine, guanine, cytosine, and uracil.

## Ribosomes

Very small cell organelles that consist of RNA and proteins, and function in protein synthesis.

## Risk

The probability that a hazard or effect will occur at a specific level of exposure.

## Risk Assessment

The process by which the probability that an adverse effect will occur at a defined exposure level is determined.

## Risk Characterization

The final stage in the risk assessment process, which involves predicting the frequency and severity of effects in exposed populations.

## Risk Management

The process of weighing policy alternatives and selecting the most appropriate regulatory action based on the results of risk assessment and social, economic, and political concerns.

## S

## Safety Factor

Factors used in the calculation of acceptable human or environmental exposures. They are applied to data from laboratory experiments or epidemiology studies. Factors of 10 are normally used to account for such uncertainties in the data on which risk assessments are made. Similar to uncertainty factors.

## Sarcoma

A malignant tumor arising in connective or muscle tissue. They are usually spread by the blood stream and frequently metastasize to the lung.

## Saxitoxin

A potent neurotoxin present in some shellfish poisoning that produces its effect by blocking sodium channels.

## Schwann Cells

A very important glial cell present in the peripheral nervous system. They wrap themselves around all axons outside the CNS and form myelin, which serves like insulation.

## Secretion

A process in which molecules are actively transported out of an organ.

## Selection Bias

Systematic error that may be introduced in sampling by selecting one population over another.

## Selective Toxicity

Differences in toxicity between two species simultaneously exposed to the same substance.

## Sensitization

An immune capability that develops after an individual is exposed to a specific antigen. Subsequent exposure results in an immune reaction.

## Sensitizer

A substance that causes an allergic immune response.

## Sensory Neurons

Neurons that carry information from sensory receptors (*usually processes of the neuron*) to the CNS. They are also known as afferent neurons.

## Sister Chromatid

## Exchange (SCE)

A mutation test in which bone marrow cells or lymphocytes of exposed individuals are microscopically examined for complete chromosome breakage and errors in rejoining of chromatid fragments. Errors are detected by demonstrating that there has been an exchange in the sister chromatids during the rejoining process.

## Skeletal System

The organ system that supports and moves the body, protects internal organs, provides for mineral storage, and provides for blood formation. The main organs are the bones, cartilage, ligaments, and bone marrow.

## Slope of the Dose-Response Curve

Rate of buildup of toxic effects with increasing doses.

## Solubility

Ability of a substance to be dissolved in a solvent. The solubility is expressed according to the solvent, such as water solubility or solubility in acetone.

## Somatic Cell

A body cell other than a germ cell.

## Somatic System

The part of the nervous system under voluntary control.

## Stable Cells

Body cells that have a long lifespan with normally a low rate of division but the ability to rapidly divide upon demand. Examples are liver cells, alveolar cells of the lung, and kidney tubule cells.

## Assay

## Standard Deviation

The statistical calculation denoting the variability of responses to an exposure. One standard deviation incorporates 68% of the responses while two standard deviations incorporates 95% of the responses.

## Steatosis

Lipid accumulation in hepatocytes.

## Stimulus

A change in the environment, such as an irritant, loss of blood, or presence of a foreign chemical.

## Strychnine

An extremely poisonous natural substance that inhibits the neurotransmitter glycine at postsynaptic sites, resulting in an increased level of neuronal excitability in the CNS.

## Subchronic Toxicity

The adverse effects of a substance resulting from repeated exposure to a toxic agent over a period of several weeks or months.

## Subclinical

Showing no, or undetectable, signs or symptoms of a disease or condition. Also, the period of time between exposure and onset of symptoms.

## Substance

Physical material of which something is made. It may be element, compound, or a mixture of materials.

## Substrate

A substance acted upon. It often refers to the chemical that undergoes reaction with an enzyme.

## Synapse

The junction between the axon of one neuron and the dendrite of another neuron or an axon and a connection with a muscle cell (*neuromuscular junction*).

## Systemic toxin

A toxin that affects the entire body or many organs.

## T

## Target Organ

An organ in which a xenobiotic exerts a toxic effect.

## TD0

Toxic Dose 0%. The estimated dose at which none of the population is expected to exhibit toxic effects.

## TD50

Toxic Dose 50%. The estimated dose at which 50% of the population exhibits toxic effects.

## TD90

Toxic Dose 90%. The estimated dose at which 90% of the population exhibits toxic effects.

## Teratogenesis

The process by which a substance causes abnormal development of tissues or organs in a developing fetus.

## Teratogenicity

The development of birth defects as the result of exposure to a teratogenic toxicant.

## Tetrodotoxin

A potent neurotoxin produced in some

species of frogs, puffer fish and other invertebrates.

## Therapeutic Index (TI)

The ratio of the dose needed to produce the desired therapeutic response to the dose producing toxicity

## Threshold Dose

The dose at which a toxic effect is first encountered.

## Threshold Limit Value (TLV)

A recommendation by the ACGIH for the highest level of exposure to a chemical that is safe.

## Tissue

A group of cells with similar structure and function. There are four types of tissues: epithelial tissue, connective tissue, muscle tissue, and nerve tissue.

## TLV

see Threshold Limit Value

## Tolerance

The ability to endure unusually large doses of a substance without ill effect. Toxic effects are decreased with continued exposure to the substance.

## Total Dose

The sum of all individual doses which may be received over a period of time.

## Toxicant

An agent that produces adverse effects when absorbed into the body.

## Toxicokinetics

The pharmacokinetics of a toxic chemical.

## Toxicologist

A person who studies harmful effects of chemicals including the mechanisms by which the effects are produced and the probability that the effects will occur under specific exposure conditions.

## Toxicology

The study of the harmful interactions of chemicals on living organisms and biological systems.

## Toxin

A specific protein produced by certain plants, animals and microorganisms that is highly toxic to other organisms (e.g., *snake venom*).

## Tumor

see Neoplasm

## Tumor Suppressor

## Gene

Genes present in normal cells that serve to prevent a cell with damaged DNA from proliferating and evolving into an uncontrolled growth. Sometimes referred to as anti-oncogenes. The p53 gene is a tumor suppressor gene.

## U

## Uncertainty Factors

Factors used in the calculation of acceptable human or environmental exposures, which are applied to data from laboratory experiments or epidemiology studies. Factors of 10 are normally used to account for uncertainties in the data on which risk assessments are made. Similar

to safety factors.

## Unscheduled DNA Synthesis (UDS)

The synthesis of DNA outside the normal mitotic process, which is considered an indication of DNA damage and the first step in the process of mutagenesis. The most commonly used test for UDS measures uptake of tritium-labeled thymidine into the DNA of rat hepatocytes or human fibroblasts.

## Urinary System

The organ system responsible for the elimination of wastes; regulation of pH and the volume of blood. The main organs are the kidneys, urinary bladder, and urethra.

## V

## Vapor Pressure

The pressure exerted when a solid or liquid is in equilibrium with its own vapor. The higher the vapor pressure the higher the volatility.

## Volatility

The ability of a substance to change from liquid or solid form to a gaseous form.

## Volume of distribution (VD)

The volume of body fluid in which a compound is apparently distributed. It may consist of plasma, interstitial fluid, and intercellular fluid.

W

Y

X

Z

## Xenobiotic

A chemical foreign to the body.

 $\beta$ 

## $\beta$ -Bungarotoxin

A potent neurotoxin (*venom*) of elapid snakes that prevents the release of neurotransmitters, thus causing paralysis and death.

## Detailed Licensing

---

### Overview

**Title:** Toxicology MSDT

**Webpages:** 125

**Applicable Restrictions:** Noncommercial

#### All licenses found:

- [CC BY-NC 4.0](#): 97.6% (122 pages)
- [Undeclared](#): 2.4% (3 pages)

### By Page

- [Toxicology MSDT - CC BY-NC 4.0](#)
  - [Front Matter - CC BY-NC 4.0](#)
    - [TitlePage - CC BY-NC 4.0](#)
    - [InfoPage - CC BY-NC 4.0](#)
    - [Table of Contents - Undeclared](#)
    - [Licensing - Undeclared](#)
    - [Preface - CC BY-NC 4.0](#)
  - [1: Pathophysiology - CC BY-NC 4.0](#)
    - [1.1: What is Pathophysiology? - CC BY-NC 4.0](#)
    - [1.2: Targeted and Non-Targeted Toxicity - CC BY-NC 4.0](#)
    - [1.3: Outcomes of Targeted and Non-Targeted Toxicity - CC BY-NC 4.0](#)
    - [1.4: Cellular Response to Toxicant-Induced Injury - CC BY-NC 4.0](#)
    - [1.5: Repair & Adaptation - CC BY-NC 4.0](#)
    - [1.6: Patterns of Toxic Injury - CC BY-NC 4.0](#)
    - [Final Evaluation - CC BY-NC 4.0](#)
  - [2: Biochemistry and Molecular Genetics - CC BY-NC 4.0](#)
    - [2.1: Introduction to Biomolecules and Cell Components - CC BY-NC 4.0](#)
    - [2.2: Cell Structure and Subcellular Compartments - CC BY-NC 4.0](#)
    - [2.3: DNA and RNA Metabolism - CC BY-NC 4.0](#)
    - [2.4: Epigenetic Mechanisms - CC BY-NC 4.0](#)
    - [Section 2 Final Evaluation - CC BY-NC 4.0](#)
  - [3: Principles of Genetic Toxicology - CC BY-NC 4.0](#)
    - [3.1: Introduction to Genetic-toxicology Assay - CC BY-NC 4.0](#)
    - [3.2: Different Genetic Damages or Mutations - CC BY-NC 4.0](#)
    - [3.3: Different Genetic-Toxicology Assays - CC BY-NC 4.0](#)
    - [3.4: Different Cytotoxicity Assays - CC BY-NC 4.0](#)
    - [3.5: Epigenetics Assay - CC BY-NC 4.0](#)
    - [Section 3 Final Evaluation - CC BY-NC 4.0](#)
  - [4: Applied Systems Toxicology - CC BY-NC 4.0](#)
    - [4.1: Systems Toxicology - CC BY-NC 4.0](#)
    - [4.2: Dose Level and Applied Toxicology - CC BY-NC 4.0](#)
    - [4.3: Tools and Technologies in Systems Toxicology - CC BY-NC 4.0](#)
    - [4.4: Other Approaches for Predictive Toxicity Modeling - CC BY-NC 4.0](#)
    - [4.5: Technologies Used In Systems Biology/Toxicology - CC BY-NC 4.0](#)
    - [4.6: Takeaways Summary - CC BY-NC 4.0](#)
    - [Section 4 Final Evaluation - CC BY-NC 4.0](#)
  - [5: Regulatory Toxicology - CC BY-NC 4.0](#)
    - [5.1: Introduction to Regulatory Toxicology - CC BY-NC 4.0](#)
    - [5.2: Global Regulatory Toxicology - CC BY-NC 4.0](#)
    - [5.3: Topic 3: Regional Regulatory Toxicology - CC BY-NC 4.0](#)
    - [5.4: National Regulatory Toxicology - CC BY-NC 4.0](#)
    - [5.5: State Regulatory Toxicology - CC BY-NC 4.0](#)
    - [5.6: Non-Governmental Regulatory Toxicology - CC BY-NC 4.0](#)
    - [Section 5 Final Evaluation - CC BY-NC 4.0](#)
  - [6: Principles of Toxicology - CC BY-NC 4.0](#)
    - [Section 1: Introduction to Toxicology - CC BY-NC 4.0](#)
      - [1.1: What is toxicology? - CC BY-NC 4.0](#)
      - [1.2: Basic Terminology - CC BY-NC 4.0](#)
    - [Section 2: Dose and Dose Response - CC BY-NC 4.0](#)
      - [2.1: Dose and It's Impact on Toxicity - CC BY-NC 4.0](#)
      - [2.2: The Dose Response Relationship - CC BY-NC 4.0](#)
      - [2.3: Dose Estimates of Toxic Effects - CC BY-NC 4.0](#)
      - [2.4: Determining the Safety of a Drug - CC BY-NC 4.0](#)
      - [2.5: NOAEL and LOAEL - CC BY-NC 4.0](#)

- Section 3: Toxic Effects - *CC BY-NC 4.0*
  - 3.1: Types of Toxic Effects - *CC BY-NC 4.0*
  - 3.2: Factors Affecting Toxicity - *CC BY-NC 4.0*
  - 3.3: Systemic Toxic Effects - *CC BY-NC 4.0*
  - 3.4: Organ Specific Toxic Effects - *CC BY-NC 4.0*
- Section 4: Interactions - *CC BY-NC 4.0*
  - 4.1: Interactions - *CC BY-NC 4.0*
- Section 5: Toxicity Testing Methods - *CC BY-NC 4.0*
  - 5.1: Testing and Assessing Toxicity - *CC BY-NC 4.0*
  - 5.2: Clinical Investigations and Other Types of Human Data - *CC BY-NC 4.0*
  - 5.3: Epidemiology Studies - *CC BY-NC 4.0*
- Section 6: Risk Assessment - *CC BY-NC 4.0*
  - 6.1: Risk Assessment - *CC BY-NC 4.0*
  - 6.2: Hazard Identification - *CC BY-NC 4.0*
  - 6.3: Dose-Response Assessment - *CC BY-NC 4.0*
  - 6.4: Exposure Assessment - *CC BY-NC 4.0*
  - 6.5: Risk Characterization - *CC BY-NC 4.0*
- Section 7: Exposure Standards and Guidelines - *CC BY-NC 4.0*
  - 7.1: Exposure Standards and Guidelines - *CC BY-NC 4.0*
  - 7.2: Regulation of Consumer Products and Drug Safety - *CC BY-NC 4.0*
  - 7.3: Environmental Exposure Standards/Guidelines - *CC BY-NC 4.0*
  - 7.4: Occupational (Workplace) Exposure Standards/Guidelines/Approaches - *CC BY-NC 4.0*
- Section 8: Basic Physiology - *CC BY-NC 4.0*
  - 8.1: Introduction to Basic Physiology - *CC BY-NC 4.0*
  - 8.2: Homeostasis - *CC BY-NC 4.0*
  - 8.3: Organs and Organ Systems - *CC BY-NC 4.0*
  - 8.4: Tissues - *CC BY-NC 4.0*
  - 8.5: Cells - *CC BY-NC 4.0*
  - 8.6: Chemicals - *CC BY-NC 4.0*
- Section 9: Introduction to Toxicokinetics - *CC BY-NC 4.0*
  - 9.1: What is Toxicokinetics - *CC BY-NC 4.0*
- Section 10: Absorption - *CC BY-NC 4.0*
  - 10.1: Introduction to Absorption - *CC BY-NC 4.0*
  - 10.2: Gastrointestinal Tract - *CC BY-NC 4.0*
  - 10.3: Respiratory Tract - *CC BY-NC 4.0*
  - 10.4: Dermal Route - *CC BY-NC 4.0*
  - 10.5: Other Routes of Exposure - *CC BY-NC 4.0*
- Section 11: Distribution - *CC BY-NC 4.0*
  - 11.1: Introduction to Distribution - *CC BY-NC 4.0*
  - 11.2: Influence of Route of Exposure - *CC BY-NC 4.0*
  - 11.3: Disposition Models - *CC BY-NC 4.0*
  - 11.4: Structural Barriers to Distribution - *CC BY-NC 4.0*
  - 11.5: Storage Sites - *CC BY-NC 4.0*
- Section 12: Biotransformation - *CC BY-NC 4.0*
  - 12.1: Introduction to Biotransformation - *CC BY-NC 4.0*
  - 12.2: Chemical Reactions - *CC BY-NC 4.0*
  - 12.3: Biotransformation Sites - *CC BY-NC 4.0*
  - 12.4: Modifiers of Biotransformation - *CC BY-NC 4.0*
- Section 13: Excretion - *CC BY-NC 4.0*
  - 13.1: Introduction to Secretion - *CC BY-NC 4.0*
  - 13.2: Urinary Excretion - *CC BY-NC 4.0*
  - 13.3: Fecal Excretion - *CC BY-NC 4.0*
  - 13.4: Exhaled Air - *CC BY-NC 4.0*
  - 13.5: Other Routes - *CC BY-NC 4.0*
- Section 14: Cellular Toxicology - *CC BY-NC 4.0*
  - 14.1: Adaptation - *CC BY-NC 4.0*
  - 14.2: Cell Damage and Tissue Repair - *CC BY-NC 4.0*
  - 14.3: Cancer - *CC BY-NC 4.0*
  - 14.4: Neurotoxicity - *CC BY-NC 4.0*
- Section 15: Intuitive Toxicology and Risk Communication - *CC BY-NC 4.0*
  - 15.1: Intuitive Toxicology - *CC BY-NC 4.0*
  - 15.2: Risk Communication - *CC BY-NC 4.0*
- Section 16: Environmental Toxicology, Environmental Health, and One Health - *CC BY-NC 4.0*
  - 16.1: Environmental Toxicology - *CC BY-NC 4.0*
  - 16.2: Environmental Health - *CC BY-NC 4.0*
  - 16.3: One Health - *CC BY-NC 4.0*
- Section 17: Conclusion - *CC BY-NC 4.0*
- Back Matter - *CC BY-NC 4.0*
  - Index - *CC BY-NC 4.0*
  - Glossary - *CC BY-NC 4.0*
  - Detailed Licensing - *Undeclared*