

ORGANIC CHEMISTRY I



Xin Liu

Kwantlen Polytechnic University

Kwantlen Polytechnic University
Organic Chemistry I

Xin Liu

This text is disseminated via the Open Education Resource (OER) LibreTexts Project (<https://LibreTexts.org>) and like the hundreds of other texts available within this powerful platform, it is freely available for reading, printing and "consuming." Most, but not all, pages in the library have licenses that may allow individuals to make changes, save, and print this book. Carefully consult the applicable license(s) before pursuing such effects.

Instructors can adopt existing LibreTexts texts or Remix them to quickly build course-specific resources to meet the needs of their students. Unlike traditional textbooks, LibreTexts' web based origins allow powerful integration of advanced features and new technologies to support learning.



The LibreTexts mission is to unite students, faculty and scholars in a cooperative effort to develop an easy-to-use online platform for the construction, customization, and dissemination of OER content to reduce the burdens of unreasonable textbook costs to our students and society. The LibreTexts project is a multi-institutional collaborative venture to develop the next generation of open-access texts to improve postsecondary education at all levels of higher learning by developing an Open Access Resource environment. The project currently consists of 14 independently operating and interconnected libraries that are constantly being optimized by students, faculty, and outside experts to supplant conventional paper-based books. These free textbook alternatives are organized within a central environment that is both vertically (from advance to basic level) and horizontally (across different fields) integrated.

The LibreTexts libraries are Powered by [NICE CXOne](#) and are supported by the Department of Education Open Textbook Pilot Project, the UC Davis Office of the Provost, the UC Davis Library, the California State University Affordable Learning Solutions Program, and Merlot. This material is based upon work supported by the National Science Foundation under Grant No. 1246120, 1525057, and 1413739.

Any opinions, findings, and conclusions or recommendations expressed in this material are those of the author(s) and do not necessarily reflect the views of the National Science Foundation nor the US Department of Education.

Have questions or comments? For information about adoptions or adaptations contact info@LibreTexts.org. More information on our activities can be found via Facebook (<https://facebook.com/Libretexts>), Twitter (<https://twitter.com/libretexts>), or our blog (<http://Blog.Libretexts.org>).

This text was compiled on 03/10/2025

TABLE OF CONTENTS

Licensing

About the Author

Acknowledgements

Introduction

1: Basic Concepts in Chemical Bonding and Organic Molecules

- 1.1: Chemical Bonding
- 1.2: Lewis Structure
- 1.3: Resonance Structures
- 1.4: Resonance structures in Organic Chemistry
- 1.5: Valence-Shell Electron-Pair Repulsion Theory (VSEPR)
- 1.6: Valence Bond Theory and Hybridization
- 1.7: Answers to Practice Questions Chapter 1

2: Fundamental of Organic Structures

- 2.1: Structures of Alkanes
- 2.2: Nomenclature of Alkanes
- 2.3: Functional Groups
- 2.4: IUPAC Naming of Organic Compounds with Functional Groups
- 2.5: Degree of Unsaturation/Index of Hydrogen Deficiency
- 2.6: Intermolecular Force and Physical Properties of Organic Compounds
- 2.7: Answers to Practice Questions Chapter 2

3: Acids and Bases- Organic Reaction Mechanism Introduction

- 3.1: Review of Acids and Bases and K_a
- 3.2: Organic Acids and Bases and Organic Reaction Mechanism
- 3.3: pK_a of Organic Acids and Application of pK_a to Predict Acid-Base Reaction Outcome
- 3.4: Structural Effects on Acidity and Basicity
- 3.5: Lewis Acids and Lewis Bases
- 3.6: Answers to Practice Questions Chapter 3

4: Conformations of Alkanes and Cycloalkanes

- 4.1: Conformation Analysis of Alkanes
- 4.2: Cycloalkanes and Their Relative Stabilities
- 4.3: Conformation Analysis of Cyclohexane
- 4.4: Substituted Cyclohexanes
- 4.5: Answers to Practice Questions Chapter 4

5: Stereochemistry

- 5.1: Summary of Isomers
- 5.2: Geometric Isomers and E/Z Naming System
- 5.3: Chirality and R/S Naming System
- 5.4: Optical Activity

- 5.5: Fisher Projection
- 5.6: Compounds with More Than One Chirality Centers
- 5.7: Answers to Practice Questions Chapter 5

6: Structural Identification of Organic Compounds- IR and NMR Spectroscopy

- 6.1: Electromagnetic Radiation and Molecular Spectroscopy
- 6.2: Infrared (IR) Spectroscopy Theory
- 6.3: IR Spectrum and Characteristic Absorption Bands
- 6.4: IR Spectrum Interpretation Practice
- 6.5: NMR Theory and Experiment
- 6.6: ^1H NMR Spectra and Interpretation (Part I)
- 6.7: ^1H NMR Spectra and Interpretation (Part II)
- 6.8: ^{13}C NMR Spectroscopy
- 6.9: Structure Determination Practice
- 6.10: Answers to Practice Questions Chapter 6

7: Nucleophilic Substitution Reactions

- 7.1: Nucleophilic Substitution Reaction Overview
- 7.2: $\text{S}_{\text{N}}2$ Reaction Mechanism, Energy Diagram and Stereochemistry
- 7.3: Other Factors that Affect $\text{S}_{\text{N}}2$ Reactions
- 7.4: $\text{S}_{\text{N}}1$ Reaction Mechanism, Energy Diagram and Stereochemistry
- 7.5: $\text{S}_{\text{N}}1$ vs $\text{S}_{\text{N}}2$
- 7.6: Extra Topics on Nucleophilic Substitution Reaction
- 7.7: Answers to Practice Questions Chapter 7

8: Elimination Reactions

- 8.1: E_2 Reaction
- 8.2: E_1 Reaction
- 8.3: E_1/E_2 Summary
- 8.4: Comparison and Competition Between $\text{S}_{\text{N}}1$, $\text{S}_{\text{N}}2$, E_1 and E_2
- 8.5: Answers to Practice Questions Chapter 8

9: Free Radical Substitution Reaction of Alkanes

- 9.1: Homolytic and Heterolytic Cleavage
- 9.2: Halogenation Reaction of Alkanes
- 9.3: Stability of Alkyl Radicals
- 9.4: Chlorination vs Bromination
- 9.5: Stereochemistry for Halogenation of Alkanes
- 9.6: Synthesis of Target Molecules- Introduction of Retrosynthetic Analysis
- 9.7: Answers to Practice Questions Chapter 9

10: Alkenes and Alkynes

- 10.1: Synthesis of Alkenes
- 10.2: Reactions of Alkenes- Addition of Hydrogen Halide to Alkenes
- 10.3: Reactions of Alkenes- Addition of Water (or Alcohol) to Alkenes
- 10.4: Reactions of Alkenes- Addition of Bromine and Chlorine to Alkenes
- 10.5: Reaction of Alkenes- Hydrogenation
- 10.6: Two Other Hydration Reactions of Alkenes

- [10.7: Oxidation Reactions of Alkenes](#)
- [10.8: Alkynes](#)
- [10.9: Answers to Practice Questions Chapter 10](#)

[Index](#)

[Glossary](#)

[Detailed Licensing](#)

Licensing

A detailed breakdown of this resource's licensing can be found in [Back Matter/Detailed Licensing](#).

About the Author

Xin Liu, Kwantlen Polytechnic University

xin.liu@kpu.ca



Dr. Xin Liu, Author

Dr. Xin Liu has been a faculty member at the Department of Chemistry, KPU since 2008. Other than teaching Organic Chemistry and first-year General Chemistry courses, she has also been actively involved in curriculum review and new course development. Having a keen interest in Open Education Resource, Dr. Liu hope to make more contributions in this fast growing area, to make learning accessible to everyone.

Acknowledgements

It was my great honour to be granted Educational Leave and an OER Creation Grant at KPU, this open textbook project would not have been possible without these funding supports. Special thanks to Dr. Rajiv Jhangiani, Mr. Todd Mundle and Dr. Fergal Callaghan for their advice and their help on the grant applications. I would also like to show my appreciation to Dr. Elizabeth Worobec and Dr. Joel Murray, Deans of Faculty of Science and Horticulture, for their support on the project since the very beginning. Furthermore, I wish to extend my thanks to my colleagues, Suzanne Pearce, for sharing her experience working with open textbooks, as well as Dr. Deepani Indurugalla, Dr. Richard Popoff and Dr. David Sud, for their feedbacks, and everyone in the Chemistry Department for their comments and help.

The Organic Chemistry I open textbook was possible through in kind support and project funding from KPU Open's Open Educational Resources [Grant Program](#) and sustained by KPU Library's [Open Publishing Suite \(OPUS\)](#). Help from Urooj Nizami, Karen Meijer-Kline and Caroline Daniels was greatly appreciated, it was with their patience and professionalism that this project could be completed.

Introduction

What Is Organic Chemistry and Why Is It Important?

On a lovely Saturday afternoon in April, you are relaxing in a garden whilst enjoying a hot cup of coffee. Colourful spring blossoms lace the air with a pleasant aroma, and the green grass, warm sunshine and rich espresso make the afternoon a charming occasion.

Your mind begins to drift as you contemplate the combination of scents, colours and tastes that surround you in this moment, and how they make up the human experience's unique and fascinating complexities.

If you have ever wondered about the origins of nature's vibrant hues or the reasonings behind the alluring flavour of coffee, you would be able to find every answer within the elaborate spectrum of knowledge in the study of Organic Chemistry.

Organic chemistry is the chemistry of compounds containing the carbon element: the common element of all living organisms. **Anthocyanins** are the pigments that give flowers their various colours, **chlorophyll** is responsible for the green shades of grass is involved in the photosynthesis process of plants, and **caffeine** is what makes coffee function the way that it does. All these substances contain **carbon**, and they are all organic compounds.

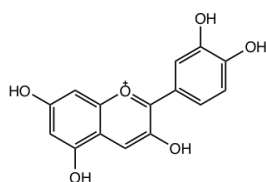

Cyanidin: an anthocyanin in reddish color

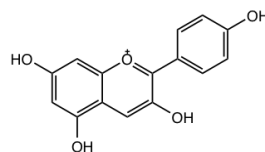

Pelargonidin: an anthocyanin in orange color

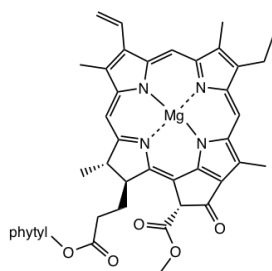

Chlorophyll a

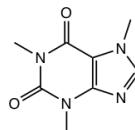
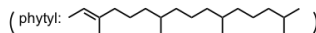

Caffeine

Image of a Cyanidin, Pelargonidin, Chlorophyll a, and Caffeine

The root of the term *organic* dates back from over two hundred years ago, when its original meaning did not even involve the element of carbon. The word *organic* was first introduced in 1807 by Jöns Jakob Berzelius, a Swedish chemist, and was used to refer to compounds derived from living organisms. It was once believed that organic compounds could only be obtained directly from nature as they contained a mystical essence of life known as “vita force”, therefore making it impossible to create organic compounds artificially. This theory was shattered by a famous experiment conducted by German chemist Friedrich Wohler in 1828. In his experiment, Wohler successfully synthesized the crystal urea by heating ammonia and cyanic acid together. The synthesis of urea marked a new era in the history of organic chemistry, not only redefining the term *organic*, but also rerouting organic chemistry into a completely new scientific discipline. The contemporary definition of *organic*, being carbon-containing compounds, is now the scientific way of describing the term. However, it has remained true over the years that organic compounds are essential to every known lifeform, as an abundance of organic molecules constitute all living organisms.

There are two additional notes regarding the modern definition of *organic*. Firstly, while it is true that organic compounds are those containing the element carbon, it is important to know that not all compounds that contain carbon are organic compounds. For example, calcium carbonate (CaCO_3), the primary component in certain rocks and chalk, can never be labelled as organic. Secondly, the “organic” food that is often found in supermarkets refers to the fact that the agricultural products were grown without the use of artificial pesticides, herbicides, or synthetic fertilizers, and has nothing to do with the presence of carbon in their chemical structures. This use of the word *organic* is possibly derived from the old definition, implying that the products came from nature, without human intervention.

As you may have been able to deduce, organic chemistry can be found in every corner of the world around us. From the food we eat, (the carbohydrates in bread, the protein in meat, the fructose in fruit, and more) to the fabric we wear, (cotton, nylon, polyester) and the fuels that power the technology around us (gasoline, natural gas, coal), the list of organic compounds involved in our lives is endless. An important significance in the application of organic chemistry is its critical role in the development of medicine and pharmaceuticals. The active ingredients found in medicine are most often organic compounds, either isolated from naturally occurring materials or synthesized in a lab. Just a few well-known examples include Aspirin, Tylenol, penicillin, insulin, Warfarin, and Tamiflu. The rapid developments of the pharmaceutical industry, in which organic chemistry has acted as a major driver, have saved millions of lives and has dramatically improved today's quality of life.

The magic element that is the key to organic chemistry and all living organisms is **carbon**. What is it about the carbon element that makes it so special? This can mainly be attributed to the special bonding ability that carbon possesses. Carbon atoms can form strong covalent bonds with other carbon atoms in the form of chains and rings, and it also forms strong bonds with other elements such as hydrogen, oxygen, nitrogen, sulfur and more. As a result, the structures of organic compounds are hugely diverse and can be rather complex.

Tips for Studying Organic Chemistry

Learning organic chemistry can be both exciting and challenging. The most commonly misleading learning strategy is the notion that "I can be successful by simply memorizing everything". While memorization may be necessary at times, it is but a small fraction of what is needed to learning organic chemistry; the more important factor is your understanding. There are many structures, reactions and mechanisms involved in the course, and surface-level memorization will not carry you all the way through. However, if you know the connections between the structures, understand the underlying principles of the reactivity of certain compounds, and can tell the similarities and differences between different mechanisms, you will find that it becomes much easier. A few suggestions for learning include:

- Rewrite your own notes when studying. For example, restate the concepts in your own words, or write a map of the concepts that are related.
- Practice makes perfect. Do as many practice questions as you can, and try to make your own questions to double check your understanding.
- Use molecule model sets for certain topics.

About the Book

Due to the high price barrier, about half of Organic Chemistry students at KPU do not have access to the textbook. This has become a serious issue that significantly affects the learning outcomes for the course. The creation of this open textbook is intended to provide a solution to this problem and help students get success in this course.

The book contains ten chapters, with the contents cover from the basic concepts on chemical bonding, functional group, to stereochemistry, spectroscopy for structure determination (IR and NMR) and organic reactions (nucleophilic substitution, elimination, radical substitution of alkanes, addition and oxidation reactions of alkenes, preparation and reactions of alkynes).

Organic Chemistry is a challenging subject for many students. To help readers understand the concepts more easily, simple and concise languages are intentionally applied in the book. The featured shaded textbox areas are included frequently in the book, where readers can find useful learning tips, reminder of common errors, comparison between similar concepts. To help readers develop problem-solving skills, a small section labelled as "strategy" is usually given for the examples in the book. Readers are encouraged to try solving the problems by themselves with helpful hints provided in the "strategy", and then compare their work with the detailed solutions provided afterwards. Because of limited time availability, not many practice questions are included in this book. We hope that more questions, particularly questions with different level of difficulties, will be added in the future edition of the book.

CHAPTER OVERVIEW

1: Basic Concepts in Chemical Bonding and Organic Molecules

- 1.1: Chemical Bonding
- 1.2: Lewis Structure
- 1.3: Resonance Structures
- 1.4: Resonance structures in Organic Chemistry
- 1.5: Valence-Shell Electron-Pair Repulsion Theory (VSEPR)
- 1.6: Valence Bond Theory and Hybridization
- 1.7: Answers to Practice Questions Chapter 1

Thumbnail: Four sp^3 orbitals. (CC BY SA 3.0; Jfmelero via Wikipedia)

This page titled [1: Basic Concepts in Chemical Bonding and Organic Molecules](#) is shared under a [CC BY-NC-SA 4.0](#) license and was authored, remixed, and/or curated by [Xin Liu \(Kwantlen Polytechnic University\)](#).

1.1: Chemical Bonding

To summarize simply, a chemical bond is the attractive force holding atoms or ions together. Such attractive interaction leads to a more stable state for the whole system comparing to individual atoms.

Valence electrons play a fundamental role in chemical bonding. In the electron configuration of an atom, the outermost shell is called the valence shell, and the **electrons in the valence shell (outermost shell)** are known as **valence electrons**. Take the carbon atom for example: the electron configuration of carbon is $1s^2 2s^2 2p^2$. The outermost shell is the 2nd principal shell, so there are 4 valence electrons in carbon. Valence electrons are the electrons that are the furthest away from the nucleus, and thus experience the least attraction from the nucleus and therefore are most reactive. They play the most important role in chemical bonding.

Exercises 1.1

Determine the number of valence electrons for following elements: B, N, O, Cl, Mg.

[Answers to Practice Questions Chapter 1](#)

Ionic Bond and Covalent Bond

There are two major types of chemical bonding: **ionic bonds** and **covalent bonds**. An ionic bond is a bond that results from the electrostatic attraction (force) between ions of opposite charges. Ionic bonds apply to ionic compound, such as sodium chloride (NaCl).

In simple ionic compounds, the metal element loses valence electron(s) to form the cation and the non-metal element gains electron(s) to form the anion. With the proper number of electron(s) lost or gained, both the cation and the anion achieve a full outer shell that contains eight electrons, as in the following examples of Na^+ , Ca^{2+} , Cl^- and O^{2-} . According to Lewis's Theory, **an atom is most stable if its outer shell is filled or contains eight electrons**. This is also called the **octet rule**.

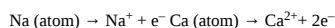

A covalent bond is a bond formed through the sharing of electron pairs between the two bonding atoms. The shared electron pairs are mutually attracted by the nuclei of both atoms. By sharing the electron pairs, both atoms also gain a filled outer shell, or an **octet**. Almost all of the bonds involved in organic compounds are covalent bonds.

Covalent bond can be non-polar or polar.

For covalent bonds formed between two identical atoms, the electron pairs are shared equally between the two nuclei. Electron density is distributed evenly through the bond, making the bond a non-polar bond. Examples include all homonuclear molecules, such as H-H, Cl-Cl, O=O, N=N.



Figure 1.1a nonpolar covalent bond and polar covalent bond

For heteronuclear bonds (the bond formed between two different atoms), the electron pairs are not shared evenly, and the bond is polar. The electron pairs are *more* attracted to the atom that has the *stronger ability* to pull the electron pairs towards itself. This ability is measured with **electronegativity**. The relative values of electronegativity (EN) are listed using the scale devised by Linus Pauling, as summarized in the following table:

EN increase																				EN increase			
	H 2.1																				H 2.1		
	Li 1.0	Be 1.5																	B 2.0	C 2.5	N 3.0	O 3.5	F 4.0
	Na 0.9	Mg 1.2																	Al 1.5	Si 1.8	P 2.1	S 2.5	Cl 3.0
	K 0.8	Ca 1.0	Sc 1.3	Ti 1.5	V 1.6	Cr 1.6	Mn 1.5	Fe 1.8	Co 1.8	Ni 1.8	Cu 1.9	Zn 1.7	Ga 1.6	Ge 1.8	As 1.9	Se 2.4	Br 2.8						
	Rb 0.8	Sr 1.0	Y 1.2	Zr 1.4	Nb 1.6	Mo 1.8	Tc 1.9	Ru 2.2	Rh 2.2	Pd 2.2	Ag 1.9	Cd 1.7	In 1.7	Sn 1.8	Sb 1.9	Te 2.1	I 2.5						
	Cs 0.7	Ba 0.9	La 1.1	Hf 1.3	Ta 1.5	W 1.7	Re 1.9	Os 2.2	Ir 2.2	Pt 2.2	Au 2.4	Hg 1.9	Tl 1.8	Pb 1.9	Bi 1.9	Po 2.0	At 2.2						
	Fr 0.7	Ra 0.9																					

Figure 1.1b Electronegativity Values in Pauling Scale

Notes about electronegativity values for Organic Chemistry purposes:

- It is much more important to know the trend of electronegativity than to memorize the values. The trend is that EN values decrease along the group from top to bottom and increase along the period from left to right (the trend mainly works for Main Group elements, not transition metal elements).
- It is very useful (although not mandatory) to know the EN values of a few select elements: F (4.0, highest), O (3.5), N (3.0), C (2.5) and H (2.1).
- The EN of C (2.5) and H (2.1) is rather close, which makes the C-H bond (the bond involved in all organic compounds) technically non-polar.

With the introduction to the concept of electronegativity, bond polarity can be represented with the electronegativity difference between the two bonding atoms, which is known as ΔEN . For non-polar bonds, ΔEN equals to zero, and for polar bonds, ΔEN is not zero. The greater the ΔEN , the more polar the bond is.

Exercises 1.2

- Identify the following bonds as "polar" or "non-polar": C-C, C-H, B-F, O-O, C=N
- Rank the following bonds in order of increasing bonding polarity: C-S, C-O, C-F (referring to the trend of EN, you do not need to use the exact EN values).

[Answers to Practice Questions Chapter 1](#)

Because of the electronegativity difference, the atom with the higher EN attracts the shared electron pairs more strongly, therefore bearing a slightly negative charge (δ^-). The other atom with a lower EN bears a slightly positive charge (δ^+). The direction of the bond polarity can be indicated with an arrow, with the head of the arrow pointing to the negative end and a short perpendicular line near the tail of the arrow marking the positive end. The following example of an H-Cl molecule indicates how to show the bond polarity and partial charges of the polar bond.



1.2: Lewis Structure

The Lewis structure is a structure that shows the bonding between atoms as short lines (some books use pairs of dots), and non-bonding valence electrons as dots.

1.2.1 Lewis Structure of Diatomic Molecules

To learn about Lewis structures, we will start with the Lewis symbol. The Lewis symbol is the chemical symbol of an element with valence electrons represented as dots. The Lewis symbols of some elements are shown here:

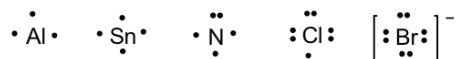

Figure 1.2a The Lewis structures of aluminum, tin, nitrogen, chlorine and bromine

For simple **diatomic molecules**, combining the Lewis symbols of each element gives its Lewis structure.

H₂ example: (H only needs two electrons; usually referred to as a **duet**.)

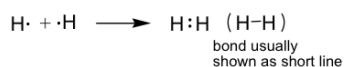

Figure 1.2b The Lewis structure of Hydrogen

F₂ example:

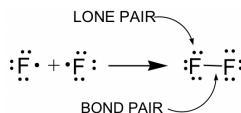

Figure 1.2c The Lewis structure of the Fluorine molecule

Terms used in Lewis structures (see example of F₂):

- **Bonding pair:** The pair of valence electrons involved in a covalent bond. The covalent bonds are drawn as short lines in this book, and one covalent bond means one pair of bonding electrons, that is 2 electrons. Single bonds and multiple bonds (double or triple bonds) may be involved.
- **Lone pair:** The pairs of valence electrons **not** involved in the covalent bond. Lone pair electrons can also be called non-bonding electron pairs.

Special note: Non-bonding electrons can also be unpaired (single) electrons. A species with one or more unpaired (single) electrons is called a radical (free radical). More examples of radicals with single electrons will be in **section 1.2.5** and **Chapter 9**.

HCl example:

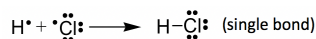

Figure 1.2d The Lewis structure of covalent bond between hydrogen and chlorine

O₂ example:

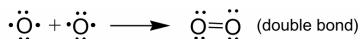

Figure 1.2e The Lewis structure of a covalent bond between two oxygen atoms

Exercises 1.3

Draw the Lewis structure of the N₂ molecule.

[Answers to Practice Questions Chapter 1](#)

1.2.2 Lewis Structures of Polyatomic Molecules or Ions

For more complicated **polyatomic molecules and ions**, the Lewis structures cannot be obtained by simply combining Lewis symbols. A specific procedure with certain steps have to be followed. It is very important that you follow the following **procedure** in order to get the correct Lewis structures for polyatomic molecules and ions.

Lewis Structure Drawing Procedure for Polyatomic Molecules and Ions

1. Calculate the total number of valence electrons. For ions, make sure charges are properly included in the calculation. For example of NH_4^+ cation:

the total number of electrons = 5 (N atom) + 4×1 (four H atoms) - 1 (minus the charge for cation) = 8 valence electrons

2. Write a plausible skeletal structure using the following steps:

a) Write atomic symbols for the central and terminal atoms.

- Hydrogen atoms are always terminal
- Central atoms are generally those with the lowest electronegativity
- Carbon atoms are always central

b) Connect the central atom with each of the terminal atom by drawing a single bond.

3. For each single bond, subtract two electrons from the total number of valence electrons.

4. Using the remaining valence electrons, complete the octets of the terminal atoms first, and then complete as many as possible for the central atoms.

5. If you have used up all of the valence electrons to complete octets for all of the atoms, you are done.

6. If not, then complete the octets of all central atoms by moving lone-pairs from terminal atoms to form multiple bonds.

7. Calculate the Formal Charges on all atoms and label the non-zero formal charges in the structure:

Formal Charge on an atom = No. of valence electrons in free atom - No. of lone pair electrons - $\frac{1}{2}$ (No. of bonding electrons)

Formula 1.1

Examples: Here we will take CO_2 molecule as an example to explain the procedure step by step:

1. Total number of valence electrons: 4 (C atom) + 2×6 (2 O atoms) = 16

Always **DOUBLE CHECK**: In the correct Lewis structure, the total number of electrons involved (bonding plus non-bonding electrons) must be **equal** to this number, less or more are both incorrect!!

2. Write a plausible skeletal structure:

Carbon atoms are always central, so the skeletal structure is: O — C — O

3. Four electrons are used so far, and there are $16 - 4 = 12$ electrons remained.

4. The remaining 12 electrons must be used to complete the octet for both terminal O atoms first, and no electrons left after that.

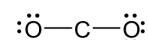

It is very important to keep in mind that the remaining electrons should be used to give the octet of **terminal atoms first!**

5. The central C atom does not get octet yet, we should do next step.

6. Moving one lone pair from each terminal O atom, the following structure is obtained.

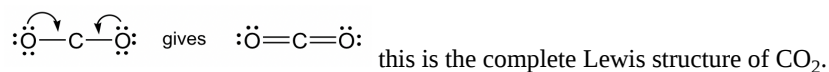

For Lewis structure purposes, the lone-pairs can only be moved **from terminal atoms to the central** atom to form multiple bonds, **not** the other way around.

7. Formal charges check: all atoms have formal charges equals to 0 in this structure.

$$\text{FC (C)} = 4 - \frac{1}{2} \times (4 \times 2) = 0$$

$$\text{FC (O)} = 6 - 4 - \frac{1}{2} \times (2 \times 2) = 0$$

Since the two oxygen atoms have the same bonding, one calculation is enough for both oxygen atoms.

1.2.3 Guidelines about Formal Charges in Lewis Structures

The purpose of formal charges is to compare the *difference* between the number of valence electrons in the free atom and the number of electrons the atom “owns” when it is bonded. The smaller the difference the “happier” (more stable) the atom is. The

atom owns *all* of the lone pair (non-bonding) electrons and *half* of the bonding (shared) electrons, which is why the formula is in the way given in **Formula 1.1**.

Formal charges can be used as guidelines to determine the plausibility of Lewis structures by comparing the stability of non-equivalent resonance structures, which is particularly important for organic species. The rules about formal charges are:

- The sum of the formal charges must equal to the total charge on the molecule or ion.
- Formal charges should be as small as possible (comparing the absolute value of formal charges for such purposes).
- “-” FC usually appears on the most electronegative atoms (with the stronger ability to pull the shared electrons; this atom is “winning” electrons in the sharing).
- “+” FC usually appears on least electronegative atoms (with the weaker ability to pull the shared electrons; this atom is “losing” electrons in the sharing).
- Structures having formal charges of the same sign on adjacent atoms are unlikely.

There is a *derived way* for calculating formal charge: since each bond contains 2 electrons, half of the bonding electrons simply equals to the number of bonds. So, the formal charge can also be calculated based on the derived version of the formula:

Formal Charge on an atom = No. of valence electrons in free atom – No. of lone pair electrons – No. of covalent bonds around the atom **Formula 1.2**

Double bonds count as 2 and triple bond count as 3 in **Formula 1.2**. Both **Formula 1.1** and **1.2** work for counting the formal charge; you can choose either one for your convenience. While almost all of the other textbooks show **Formula 1.1** as the official way, **Formula 1.2** is easier to use and can be regarded as the practical one based on experience.

Exercises 1.4

Why is the following structure not the best way to show the Lewis structure of CO₂ ?

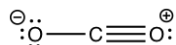

Answers to Practice Questions Chapter 1

1.2.4 Kekulé Structures vs Lewis Structures

The complete Lewis structure always has to include all the *bonding* electrons and *lone pair* electrons. However, organic species are usually shown as Kekulé structures (more discussion will be in **Chapter 2**) with *all the lone pair electrons completely omitted* (with exceptions to the lone pairs that are shown to highlight special properties). Therefore, when viewing Kekulé structures, it is very helpful to keep in mind that atoms other than C and H should have a certain number of lone pairs. Examples of Kekulé structures of some compounds are given here:

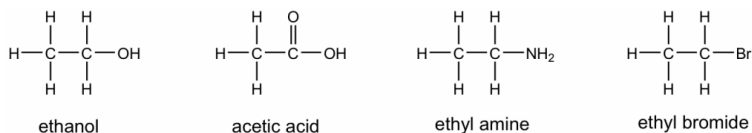

Figure 1.2f The Kekulé structures of ethanol, acetic acid, ethyl amine, and ethyl bromide

To count how many lone pairs should be involved on a certain atom, apply the octet rule. All of the atoms (except H) should have 8 electrons around it, therefore, N usually has 1 lone pair, O has 2 lone pairs and halogens have 3 lone pairs.

1.2.5 Exceptions to Octet Rule in Lewis Structure

So far we have always been applying the **octet rule** in Lewis structures, however there are some cases in which the rule does not apply. For example, H only needs 2 electrons. Here we will see some other cases where the octet rule is compromised.

• Odd number of electrons

If the total number of valence electron is an odd number, the octet rule can not be applied to all atom in the species. The examples could include NO (nitrogen monoxide or nitric oxide), NO₂ (nitrogen dioxide) and alkyl radicals??

NO molecule: Although NO is a diatomic molecule, it is possible to draw the Lewis structure by following the **procedure**. Depending on which atom is given the octet first in Step 4, you may get two possible structures. By applying the formal charge guideline, we can decide that the first structure is the better choice with zero formal charges.

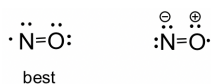

Figure 1.2g NO molecule Lewis structure

NO₂ molecule: The Lewis structure of NO₂ molecule is shown below.

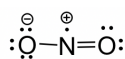

Figure 1.2h NO₂ molecule Lewis structure

For above molecules, they all contain unpaired (single) electrons. The neutral species that contain an unpaired electron is called **radical** (or free radical). When the carbon atom of a alkyl group has an unpaired electron, the species is the alkyl radical.

Alkyl radicals: The simplest example of alkyl radical is •CH₃, with the total number of valence electron as 7. The structure is:



Figure 1.2i CH₃ Lewis structure

More discussions about the properties and reactions of radicals will be included in Chapter 9.

• Incomplete Octet

An incomplete octet means that the atom has less than 8 electrons involved. This could be because the total number of valence electrons is less than 8, or due to formal charge concerns.

BH₃ molecule: The total number of valence electrons is 6, so the central boron atom does not get an octet.



Figure 1.2j BH₃ molecule Lewis structure

BF₃ molecule: Even though all of the atoms do have a chance to get octets in the structure of BF₃, the actual structure of BF₃ keeps the incomplete octet. Applying the FC guideline explains why the first structure is the better choice. Similar examples include BeF₂, AlCl₃.

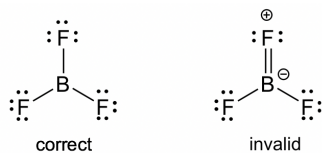

Figure 1.2k BF₃ molecule Lewis structure

F is the atom with the highest electronegativity, therefore F **never** has “+” formal charge in any plausible Lewis structure!

CH₃⁺: This is another reactive intermediate in organic reactions (more discussions in Chapter 8). FC calculations indicate that the “+” charge lies on the C atom, so such a species is also called a **carbocation**. Carbon has an incomplete octet.



Figure 1.2l CH₃⁺ molecule Lewis structure

• Expanded Valence Shell

For elements in Period 3 or higher, they can have more than 8 electrons if that helps to lower the formal charges. Common examples involve the species with P, S or Cl, etc as central atoms. Sometimes multiple double bonds are necessary to minimize the formal charge of the central atom. The structure of the phosphate anion, PO₄³⁻, is given here as an example.

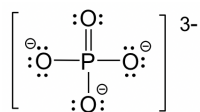

Figure 1.2m phosphate anion Lewis structure

Elements in Period 3 (or higher) have 3 (or more than 3) principle shells, so the *d* orbital is available in the valence shell. That is why they can accommodate more than 8 electrons.

Key Takeaways

For elements in 2nd period, C, N, O, F and Ne, the *maximum* number of electrons involved in Lewis structure is **eight!!!**

This page titled [1.2: Lewis Structure](#) is shared under a [CC BY-NC-SA 4.0](#) license and was authored, remixed, and/or curated by [Xin Liu \(Kwantlen Polytechnic University\)](#).

1.3: Resonance Structures

In the case that more than one reasonable (plausible) Lewis structure can be drawn for a species, these structures are called **resonance structures** or **resonance contributors**. Resonance structures can be either equivalent or non-equivalent.

Equivalent Resonance Structures

Let's consider the example of carbonate anion, CO_3^{2-} :

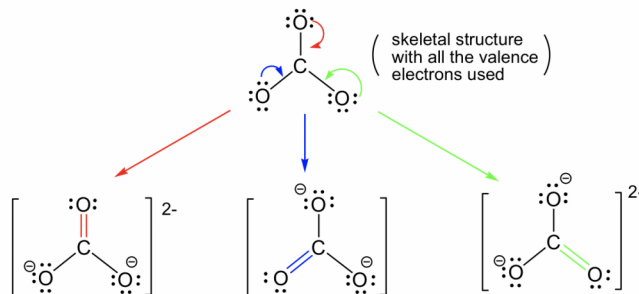

three Lewis structures are obtained by following arrow in different color

Figure 1.3a Versions of the carbonate anion Lewis structure

By following Step 6 in the **Lewis structure drawing procedure**, the double bond can be built between the central C and any of the terminal O's to generate three structures, and they all look "the same". However, they are not really identical (or same), they are just equivalent. Each structure is called a **resonance structure**, and they can be connected by the double-headed resonance arrow. There are total three equivalent resonance structures for CO_3^{2-} , and the actual structure of CO_3^{2-} is the hybrid of the three resonance contributors.

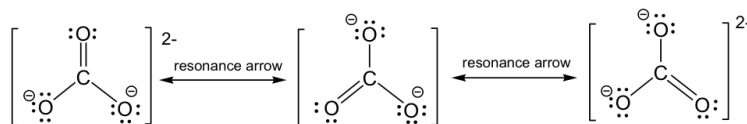

three equivalent resonance contributors of carbonate anion

Figure 1.3b Three equivalent resonance contributors of carbonate anion

The arrows used here to connect between resonance structures is the "**resonance arrow**", which has double arrow heads. Resonance structures have to be connected using resonance arrows.

Since the resonance structures are equivalent, they are all in the same level of energy and have the same stability, so they make the same contributions to the actual structure of CO_3^{2-} . This is supported by the experimental evidence that all the carbon-oxygen bonds in CO_3^{2-} are the same bond length, which is longer than a regular double bond but shorter than a single bond. As a result of the resonance structures, the two negative charges in CO_3^{2-} are not localized on any oxygen atoms, but are spread evenly among all three oxygen atoms, and is called charge **delocalization**. Because of charge delocalization, each oxygen atom has two-thirds of a full negative charge. Charge delocalization helps to *stabilize* the whole species. The stability a species gains from having charge delocalization through resonance contributors is called **resonance stabilization effect**. The greater the number of resonance contributors, the greater the resonance stabilization effect, and the more stable the species is.

The actual structure of the carbonate anion is a combination of all the three equivalent resonance structures, that can be called a hybrid. What does the actual structure look like, and can we draw one structure on paper to show the actual structure? The actual structure can not be shown with a conventional Lewis structure, because the regular Lewis structures do not include partial charges, and there is two-thirds of a full negative charge on each oxygen atom in CO_3^{2-} . An attempt to show the hybrid structure can be by using dashed lines to show that the bond between carbon and oxygen is somewhere between a single and double bond, and each oxygen atom has partial charges.

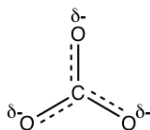

Figure 1.3c Dashed lines drawn on the CO_3 molecule Lewis structure to show the actual structure and partial charges

The delocalized charges can also be represented by the calculated **electrostatic potential map** of the electron density in the CO_3^{2-} anion. In an electrostatic potential map, regions with different charges are shown in different colours. More specifically, colours trending towards red means higher negative charges, while colours trending toward blue means more positive charge (the colour system generated by different softwares might not be same, but will follow the same trend). In the electrostatic potential map of carbonate anion below, the same shade of red of all three oxygen atoms indicate the equal charge distribution at the three oxygen atoms.

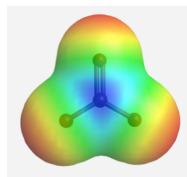

Figure 1.2d The electrostatic potential map of carbonate anion

Exercises 1.5

Draw all the equivalent resonance structures for following species. Include any non-zero formal charges in the structures.

- O_3 molecule
- nitrate anion NO_3^-
- chlorate anion ClO_3^- .

Answers to Practice Questions Chapter 1

Non-equivalent Resonance Structures

Resonance structures can also be non-equivalent. For the example of OCN^- , there are three *non-equivalent resonance structures*, depending on how the multiple bonds are formed in Step 6 of the **Lewis structure drawing procedure**.

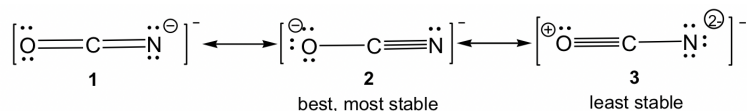

Figure 1.3e Three non-equivalent resonance structure contributors of OCN^-

For non-equivalent resonance structures, the bonding and charge distributions are different, so they are in different energy levels. Some are more stable (better) resonance structures than others. The guidelines for comparing the relative stability between non-equivalent resonance structures are (the lower the energy, the more stable the structure is and vice versa):

- The structure with complete octets is usually more stable, except in the cases in **section 1.2.4** “Exceptions to Octet Rule”.
- The structure involving the smaller formal charges is more stable.
- Negative charges should be preferentially located on atoms with greater electronegativity, and positive charges should be preferentially located on atoms with less electronegativity
- Charge separation decreases the stability (increases the energy).

By applying the rules above, we can predict that for OCN^- , structure **3** is the least stable one since it has the highest formal charges. For both structures **1** and **2**, the formal charge is “-1”. It is more preferable for negative formal charges to be on oxygen, the more electronegative atom; therefore structure **2** is the most stable one.

Exercises 1.6

Draw all of the resonance structures for azide anion, N_3^- , and indicate the most stable one.

Answers to Practice Questions Chapter 1

This page titled [1.3: Resonance Structures](#) is shared under a [CC BY-NC-SA 4.0](#) license and was authored, remixed, and/or curated by [Xin Liu](#) (Kwantlen Polytechnic University).

1.4: Resonance structures in Organic Chemistry

Resonance stabilization effect (also known as **resonance effect**), as briefly mentioned in **Section 1.3**, is one of the fundamental concepts of Organic Chemistry and has broad applications. The discussion of resonance effect heavily relies on the understanding of resonance structures. Here we will focus on how to draw resonance structures (or resonance contributors) for organic chemistry species, and how to compare the relative stabilities between the structures.

According to **resonance effect**, the greater the number of resonance contributors, the greater the resonance stabilization effect, and the more stable the species is. Therefore, to predict whether the resonance effect applies or not, we usually need to construct “new” resonance structures (contributors) based on the “original” one that is available. There are some very important rules we need to follow for such purposes.

Guidelines for Drawing Resonance Structures:

- All resonance structures must be valid Lewis structures. **(Keep in mind that all the rules applied to Lewis structures still apply here!)**
- All resonance structures must have the same atom connectivity, and only differ in the electron arrangement. **(Atoms NEVER move, only electrons move.)**
- All resonance structures have the same number of electrons and net charge. **(Formal charges on individual atom could be different, but net charge, that is the sum of all the charges, must be the same.)**
- To move electrons, only π electrons and lone-pair electrons **(NEVER move σ bonds!)** can be moved from the higher electron density area to lower electron density area by following one of the three transformations:
 - π bond forms another π bond;
 - π bond forms the lone pair electrons;
 - lone pair electrons forms a π bond.
- Use **curved arrows** to indicate the electron movement in the “original” resonance structure. The “new” resonance structure should be a “product” automatically obtained by following the arrows.
- Calculate the formal charge in the “new” structure and label any non-zero formal charges.

The way to use curved arrows show electron transfer is also called **arrow pushing**, it is a very important fundamental skill you need to master in organic chemistry. For the purpose of constructing “new” resonance structures, arrows have to be shown in the “original” structure.

Examples: Draw another resonance structure based on the given one.

1.

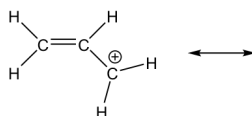

Approach: There is only one π bond in this example, and no any lone pairs, so only the π electrons can be moved around. There is a carbocation beside the π bond, which is the low electron density spot. Therefore it is reasonable to move the π electrons to the position beside carbocation to form another π bond, and that gives the “new” structure. The two resonance structures here are *equivalent*.

Solution

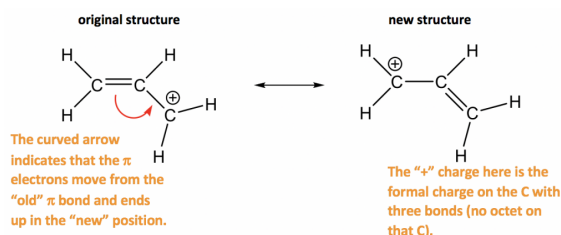

2.

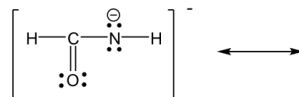

Approach: More electrons available for movement in this example: several lone pairs and one π bond. The guideline of “move electrons from the **higher** electron density area **to the lower** electron density area” provides a useful hint about where to start. The nitrogen atom has a “-” formal charge, meaning it has relatively high electron density, higher than other neutral spots. So it is reasonable to move the lone pair on nitrogen away to form a π bond (keep in mind that **lone pair can only form π bond, not another lone pair**). However, when the new π bond is formed around the carbon atom, there are 5 bonds (10 electrons) on that carbon, which is not allowed. So, another electron pair has to be moved away, and the only available electron pair to be moved is the π electrons in C=O bond. It can be moved onto the oxygen atom and become another lone pair on the oxygen atom.

Solution:

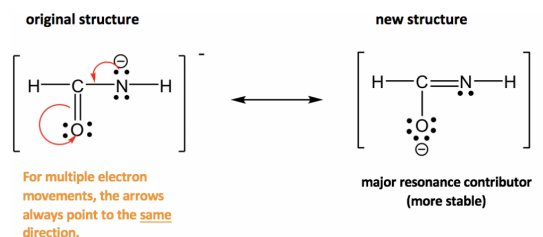

The two resonance structures in this example are *non-equivalent*, so one is more stable than the other. By applying the formal charge guideline, the “-” formal charge is more preferable on oxygen, which is more electronegative than nitrogen, so the 2nd structure is the more stable one with lower energy, and makes more contribution to the actual structure in this species. The more stable structure can also be called as the major resonance contributor.

Comparing the relative stability of different resonance contributors:

- Structures with a maximum of octets are most important.
- Charge separation usually decrease the stability (increase the energy of the contributor).
- Negative charges should be preferentially located on atoms with greater electronegativity, and positive charges should be preferentially located on atoms with less electronegativity.

Common errors for drawing resonance structures:

1. σ bond is moved
2. Atom is moved
3. More than eight electrons located around C, N or O
4. Arrows are not shown in the proper way
5. Electron pairs are moved too far away, they should only be moved to the next position/atom.

Exercises 1.7 Draw new resonance structure and compare the relative stability, show arrows in the original structure.

1.

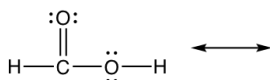

2.

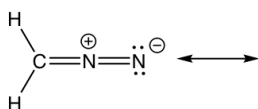

Answers to Practice Questions Chapter 1

This page titled [1.4: Resonance structures in Organic Chemistry](#) is shared under a [CC BY-NC-SA 4.0](#) license and was authored, remixed, and/or curated by [Xin Liu \(Kwantlen Polytechnic University\)](#).

1.5: Valence-Shell Electron-Pair Repulsion Theory (VSEPR)

The **Valence-Shell Electron-Pair Repulsion (VSEPR)** theory helps us to understand and predict the geometry (shape) of molecules or ions. The theory is:

- Electron pairs repel each other whether they are in chemical bonds or lone pairs.
- Valence electron pairs are oriented to be as far apart as possible to minimize repulsions.

Based on this theory, depending on the number of electron pairs (both bonding pairs and lone pairs) around the central atom, a certain shape is adopted to minimize the repulsion between electron pairs, as summarized in the table below:

Total number of electron groups (electron pairs) around central atom	Geometry (Shape) of electron groups (electron pairs)
2	linear
3	trigonal planar
4	tetrahedral
5	trigonal bipyramidal
6	octahedral

Table 1.1 Basic VSEPR Shapes

Notes:

- For VSEPR purpose, the terms “**shape**” and “**geometry**” are interchangeable; “**electron pair**” and “**electron group**” are also interchangeable.
- Multiple bonds (double or triple bond) are regarded as **one electron group** for VSEPR purpose.

For species that do not have any lone pair electrons (LP), the geometry (shape) of the species is just the same as the geometry of the electron groups.

For the example of the PCl_5 molecule, there are five electron groups on the central phosphorous, and they are all bonding pairs (BP). The shape of the electron groups is trigonal bipyramidal, and the shape of the PCl_5 molecule is trigonal bipyramidal as well. The trigonal bipyramidal shape can be drawn on paper using solid and dashed wedges: the three bonds lie within the paper plane are shown as ordinary lines, the solid wedge represent a bond that points out of the paper plane, and the dashed wedge represent a bond that points behind the paper plane.

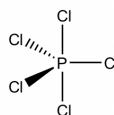

trigonal bipyramidal shape of PCl_5 molecule

Figure 1.5a Trigonal bipyramidal shape of PCl_5 molecule

However, for the species that has lone pair electrons on the central atom, the shape of the species will be *different* to the shape of the electron groups. The reason is that even though the lone pairs occupy the space, there are no terminal atoms connected with lone pair, so the lone pair become “invisible” for the shape of the species.

For the example of the water (H_2O) molecule, the central oxygen atom has two BPs and two LPs, and the shape of all the electron groups is tetrahedral. The shape of a water molecule is bent because only the atoms are counted towards the molecular shape, not the lone pair electrons.

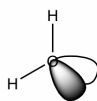

bent shape of H₂O molecule

Figure 1.5b Bent shape of H₂O molecule

The VSEPR shapes can be rather diverse, considering the different numbers of total electron pairs together with the different numbers of lone pairs involved. The most common shapes are summarized in the following table (Table 1.2). To describe a certain shape, the specific name has to be used properly, and the bond angle information is important as well.

Total number of e-groups	Geometry (shape) of all the electron groups	# of Bonding Pairs (BP) and Lone Pairs (LP)	Geometry (shape) of the species	Angles (°)
2	linear	2BP	linear	180
3	trigonal planar	3BP	trigonal planar	120
		2BP, 1LP	bent	<120
4	tetrahedral	4BP	tetrahedral	109.5
		3BP, 1LP	trigonal pyramidal	<109.5
		2BP, 2LP	bent	<109.5
5	trigonal bipyramidal	5BP	trigonal bipyramidal	120, 90, 180
		4BP, 1LP	see-saw	<120, 90, 180
		3BP, 2LP	T-shape	90, 180
		2BP, 3LP	linear	180
6	octahedral	6BP	octahedral	90, 180
		5BP, 1LP	square pyramidal	90, 180
		4BP, 2LP	square planar	90, 180

Table 1.2 Summary of specific VSEPR shapes

The website https://phet.colorado.edu/sims/html/molecule-shapes/latest/molecule-shapes_en.html provides good resources for visualizing and practicing VSEPR topics.

We will see more applications of VSEPR in organic compounds in next section.

This page titled [1.5: Valence-Shell Electron-Pair Repulsion Theory \(VSEPR\)](#) is shared under a [CC BY-NC-SA 4.0](#) license and was authored, remixed, and/or curated by [Xin Liu \(Kwantlen Polytechnic University\)](#).

1.6: Valence Bond Theory and Hybridization

1.6.1 Valence Bond Theory

We have talked about how covalent bonds are formed through the sharing of a pair of electrons; here we will apply the **valence bond theory** to explain in more detail how the sharing happens. The valence bond theory describes the covalent bond formed from the overlap of two half-filled atomic orbitals on different atoms.

Let's start with the simple molecule H_2 . The atomic electron configuration of a hydrogen atom is $1s^1$, meaning that there is one electron (which is also the valence electron) in the sphere-shaped $1s$ orbital.

When two hydrogen atoms are approaching each other, the two $1s$ orbitals overlap, allowing the two electrons (each H donates 1 electron) to pair up for the bonding with the overlapping orbitals. The shared pair of electrons are under the attraction of both hydrogen nuclei simultaneously, resulting in them serving as a "glue" that holds the two nuclei together.

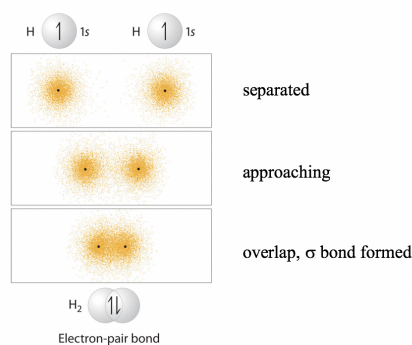

Formation of H-H σ bond

Figure 1.6a Formation of H-H bond

The overall energy changes of the system *versus* the distance between the two hydrogen nuclei can be summarized in the energy diagram below.

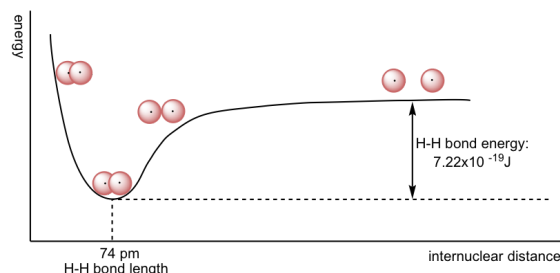

Figure 1.6b Potential energy of the hydrogen molecule as a function of internuclear distance

When the two atoms are separate, there is no overlap and no interaction. As they are getting closer, orbitals start to overlap, and there is attraction between the nucleus of one atom and the electron of the other atom, so the total energy of the system lowers. The energy lowers to its minimum level when the two atoms approach the optimal distance. The optimal distance is also defined as the **bond length**. H_2 molecules have a bond length of 74 pm (often referred to as 0.74 Å, $1\text{Å} = 10^{-10}\text{m}$). The energy difference between the most stable state (lowest energy state with optimum distance) and the state in which the two atoms are completely separated is called the **bond (dissociation) energy**. The bond energy is 7.22×10^{-19} J for one H-H bond, or 435kJ/mol.

When the two atoms get closer than the optimal distance, the repulsion between the two nuclei become predominant, and the energy of the system becomes even higher.

Another important character of the covalent bond in H_2 is that the two $1s$ orbitals overlap in a way that is referred to as head-to-head. The bond formed by head-to-head overlap is called **σ (sigma) bond**. σ bonds are cylindrically symmetrical, meaning if a cross-sectional plane is taken of the bond at any point, it would form a circle.

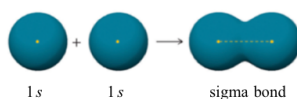

Figure 1.6c Cylindrical symmetry property of σ bond

The valence bond theory works well to explain the bonding in HF as well, with the 2p orbital of fluorine atom involved in the overlapping.

The fluorine atom has the valence electron configuration of $2s^2 2p^5$ as shown in the orbital diagram.

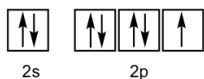

Figure 1.6d Orbital diagram of valence electrons in fluorine atom

For the three 2p orbitals, two of them are filled and the other one is half-filled with one single electron. The filled orbital cannot form bonds, so only the half-filled 2p is available for overlap. Therefore, the 1s orbital of the hydrogen atom overlaps head-to-head with the half-filled 2p orbital of the fluorine atom to form the H-F σ bond, as shown below.

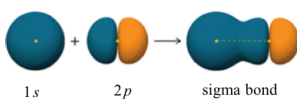

Figure 1.6e H-F σ bond

A σ bond can also be formed through the overlap of two p orbitals. The covalent bond in molecular fluorine, F_2 , is a σ bond formed by the overlap of two half-filled 2p orbitals, one from each fluorine atom as shown here.

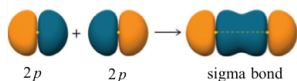

Figure 1.6f F_2 σ bond

However, when the valence bond theory is applied to organic molecules, for instance CH_4 , it does **not** work. The valence electron configuration of carbon atom is $2s^2 2p^2$ as shown in the orbital diagram.

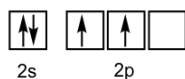

Figure 1.6g Orbital diagram of valence electrons in carbon atom

Based on the valence bond theory, with two half-filled orbitals available, the carbon atom should be able to form two bonds. However, carbon always has four bonds in any stable organic compound. To explain the bonding of carbon and other atoms that cannot fit into the simple valence bond theory, a new theory called orbital **hybridization** will be introduced as a supplement to the valence bond theory.

1.6.2 Hybridization and the Structure of CH_4

Simply speaking, hybridization means the mathematical combination of several orbitals to generate a set of new hybrid orbitals.

In the hybridization for CH_4 , the 2s and three 2p orbitals are combined to give a new set of four identical orbitals, that are called sp^3 hybrid orbitals. The symbol sp^3 here identify the numbers and types of orbitals involved in the hybridization: **ones** and **three p** orbitals. For the hybridization process,

$$\text{number of hybrid orbitals} = \text{the total number of atomic orbitals that are combined}$$

It means that with total four orbitals combined, four new hybrid orbitals are generated, and they all named as sp^3 hybrid orbitals. These new hybrid orbitals are all in the same energy level that is between those of 2s and 2p orbitals, and are directed in a tetrahedral shape overall with the angle between any two orbitals as 109.5° . Each sp^3 hybrid orbital has two lobes that are very different in size. The lobe with the larger size is in the positive phase and is responsible for bonding.

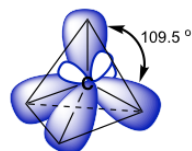
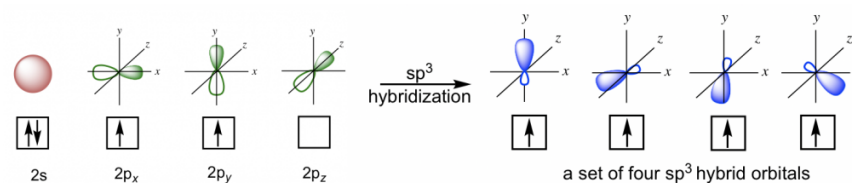

Figure 1.6h Four sp^3 hybrid orbitals oriented in tetrahedral shape

Since there are four sp^3 hybrid orbitals available, each of the four valence electrons occupies one of them, so there are four half-filled sp^3 orbitals in the carbon atom that are able to form four bonds. Therefore, the C-H bond of CH_4 is formed by the overlapping between the $1s$ orbital in the hydrogen atom and the sp^3 orbital in the carbon atom.

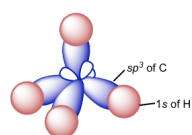

Figure 1.6i Orbital overlap of C-H bonds in methane

Because the arrangement of the four sp^3 hybrid orbitals is in a tetrahedral, the shape of the CH_4 molecule is also a tetrahedral, which is consistent with the shape predicted by VSEPR. The tetrahedral shape of the sp^3 carbon can usually be drawn using the solid and dashed wedges. Out of the four bonds, the two bonds that lie within the paper plane are shown as ordinary lines, the solid wedge represent a bond that point out of the paper plane, and the dashed wedge represent a bond that point behind the paper plane. These perspective drawings that show the 3D tetrahedral shape is particularly important in the discussion of stereochemistry in **Chapter 5**.

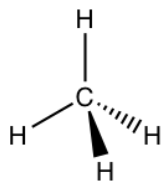

Figure 1.6j Tetrahedral shape of methane with solid and dashed wedges drawing

1.6.3 Hybridization and VSEPR

Other than sp^3 hybridization, there are also other types of hybridization that include sp , sp^2 , sp^3d and sp^3d^2 . Usually the hybridization on a certain atom can simply be determined by counting the total number of electron groups (bonding pairs and lone pairs). **The total number of electron groups just equals the total number of orbitals involved in the certain hybridization.** For example, in a CH_4 molecule, the central carbon atom has four 4 bonding pairs, so the hybridization of carbon is sp^3 (one s and three p orbitals, $1+3=4$). If a central atom has total five 5 electron groups (bonding pairs and lone pairs all together) around, then the hybridization is sp^3d (ones, three p and one d orbitals, $1+3+1=5$).

This correlation may remind you of VSEPR. Hybridization and VSEPR are two separate concepts, however they can be correlated together via the number of electron groups in common. The following table is very useful in correlating the hybridization and VSEPR shape/bond angles around the central atom and the total number of electron groups together.

Hybridization on central atom	Total number of electron pairs (BP and LP) around central atom	Geometry (Shape) of electron groups (electron pairs)

sp	2	linear
sp ²	3	trigonal planar
sp ³	4	tetrahedral
sp ³ d	5	trigonal bipyramidal
sp ³ d ²	6	octahedral

Table 1.3 Correlation between Hybridization and VSEPR

Exercises 1.8

1. What is the hybridization of the oxygen atom in H₂O molecule?
2. What is the hybridization of the xenon atom in XeF₄ molecule, and what is the shape of the whole molecule?

Answers to Practice Questions Chapter 1

1.6.4 The Hybridization and VSEPR in Organic Molecules

Organic molecules usually contain more than one central atom, so it is not practical to name the shape of the whole molecule; instead we can talk about the shape/bond angle about each central atom individually. For such purposes, make sure to include the lone pairs that are usually left out in the organic structures (refer to section 1.2.4). The different structural formulas of ethanol, acetic acid and ethanenitrile molecules are shown in the table below. The 3D molecular model for each compound is shown as well to help you visualize the spatial arrangement. We can see that the hybridization and VSEPR shapes need to be indicated for each internal atom separately. Taking the oxygen atom in the OH group of ethanol as an example, since there two pairs of lone pair electrons on the oxygen atom as well (omitted in the structures in the table though), the oxygen has sp³ hybridization and is in the tetrahedral shape.

	Kekulé structures	Perspective formula with hybridization and shape of central atoms	3D models
ethanol			
acetic acid			
ethanenitrile (acetonitrile)			

Table 1.4 Hybridization and VSEPR of organic molecule examples

Table 1.4 Hybridization and VSEPR of Organic molecule examples [\[Image Description\]](#)

1.6.5 Multiple Bonds in Organic Structure

Ethene (C₂H₄)

We will take Ethene (C₂H₄) as an example for understanding the structure of a double bond.

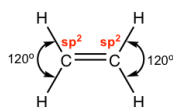

Figure 1.6k Ethene hybridization

According to the structure formula of C_2H_4 , there are three electron groups around each carbon. Through referring to **Table 1.3** it is determined that both carbons are in sp^2 hybridization, with the trigonal planar shape and a 120° bond angle. What does sp^2 hybridization mean to the carbon atom in this compound? It means that only three orbitals are involved in the hybridization (one $2s$ and two of $2p$ orbitals) out of the total four, and there is one $2p$ orbital left out, or not included in the hybridization, which is called the unhybridized $2p$.

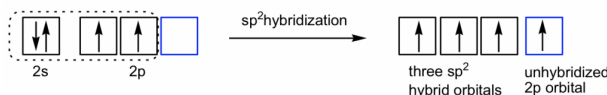
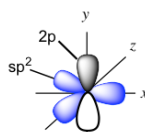

Figure 1.6l Orbital hybridization diagram of valence electrons in Ethene

The three new sp^2 hybrid orbitals and the unhybridized $2p$ are directed in the following arrangement: the three sp^2 hybrid orbitals are in the trigonal planar shape, and the unhybridized $2p$ is in the position that is perpendicular to the plane. Each orbital has one single electron, so all the orbitals are half-filled and are available for bonding. Both carbon atoms have the same set of orbitals (three sp^2 hybrid orbital and one unhybridized $2p$) as shown below.



the set of orbitals: $sp^2 + 2p$

Figure 1.6m The set of orbitals: $sp^2 + 2p$

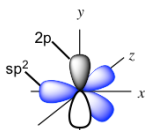

the set of orbitals: $sp^2 + 2p$

Figure 1.6n The set of orbitals $sp^2 + 2p$

When the two carbons approach each other, the sp^2 on the x axis overlaps head-to-head to form the C-C σ sigma bond, and the “unhybridized” $2p$ overlaps side-by-side to form another new bond. **The side-by-side orbital overlapping forms the π (pi) bond.**

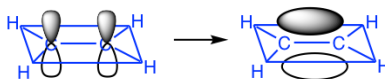

Figure 1.6o Side-by-side overlap of p orbitals leading to π (pi) bond

So now we understand that the $C=C$ double bond contains two different bonds: σ (sigma) bond from sp^2-sp^2 orbital overlapping and π (pi) bond from $2p-2p$ overlapping. Because of the π bond, the overall shape of the whole C_2H_4 molecule is co-planar.

The other sp^2 hybrid orbitals on each carbon atom overlap with $1s$ orbital of H atoms and give total four C-H σ (sigma) bonds.

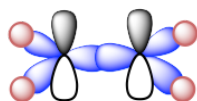

Figure 1.6p Sigma (σ) bond framework of C_2H_4

Ethyne (C_2H_2)

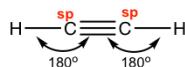

Figure 1.6q Ethyne hybridization

Ethyne C_2H_2 (common name is acetylene) has a $C\equiv C$ triple bond. Generally, triple bonds involve one σ sigma bond and two π (pi) bonds. Both carbon atom is in sp hybridization and in linear shape. With sp hybridization, each carbon has two sp hybrid orbitals and two unhybridized $2p$ orbitals. Each carbon uses one sp hybrid orbital to overlap head-to-head and gives the C-C the σ

sigma bond, meanwhile the 2p orbitals overlap side-by-side to give two π bonds as shown in the diagram below. The other sp orbitals are used for overlapping with 1s of hydrogen atoms to form C-H σ bonds.

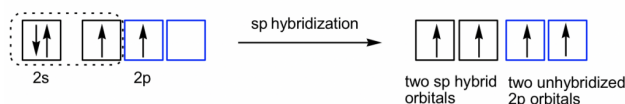
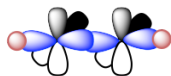
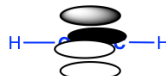

Figure 1.6r Orbital hybridization diagram of valence electrons in Ethyne



sigma (σ) bond framework of C_2H_2



two pi (π) bonds in C_2H_2

Figure 1.6s Sigma (σ) bond framework of Ethyne and two pi (π) binds of Ethyne

Image Descriptions

Table 1.4 image description: Ethanol's CH_3 , CH_2 , and OH are all in a sp^3 tetrahedral shape. Acetic acid's CH_3 , and OH are in a sp^3 tetrahedral shape and CO is in a sp^2 trigonal planar. Lastly, ethanenitrile's (acetonitrile) CH_3 in a sp^3 tetrahedral shape, and CN is in a sp linear shape. [\[Return to Table 1.4\]](#)

This page titled [1.6: Valence Bond Theory and Hybridization](#) is shared under a [CC BY-NC-SA 4.0](#) license and was authored, remixed, and/or curated by [Xin Liu \(Kwantlen Polytechnic University\)](#).

1.7: Answers to Practice Questions Chapter 1

7

Answers to Practice Questions Chapter 1

Xin Liu

1.1 Number of valence electrons:

B: 3 valence electrons

N: 5 valence electrons

O: 6 valence electrons

Cl: 7 valence electrons

Mg: 2 valence electrons

1.2

- Identify the following bond is “polar” or “non-polar”?

C-C: non-polar C-H : non-polar (very close electronegativity for C and H)

B-F : polar. O-O : non-polar C=N : polar

- Rank the following bonds in the order of increasing bonding polarity: C—S, C—O, C—F (referring to the trend of EN, no need to use the exact EN values).

bonding polarity: C—S < C—O < C—F

1.3 Draw the Lewis structure of N₂ molecule: $\text{:N}\equiv\text{N:}$

1.4 Why following structure is not the best way to show the Lewis structure of CO₂?

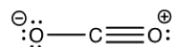

Because the formal charges are not minimized in above structure. The formal charge in the best Lewis structure of CO₂ are all zero, and the best Lewis structure of CO₂ is shown here:

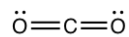

1.5 Draw all the equivalent resonance structures for following species. Include any non-zero formal charges in the structures.

- O₃ molecule

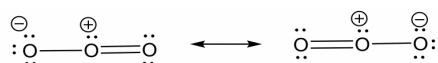

- nitrate anion NO₃⁻

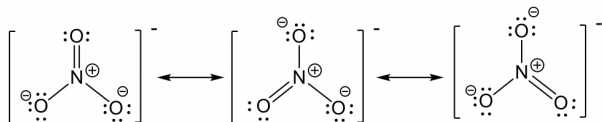

- chlorate anion ClO₃⁻

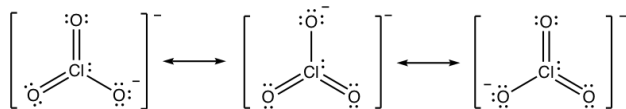

1.6 Draw all the resonance structures for azide anion, N₃⁻, and indicate the most stable one.

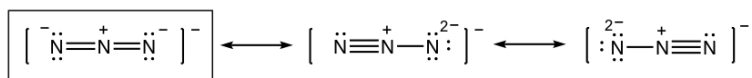

best

1.7 Draw new resonance structure and compare the relative stability, show arrows in the original structure.

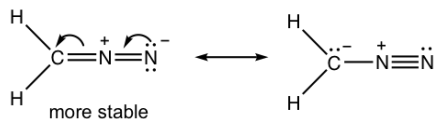
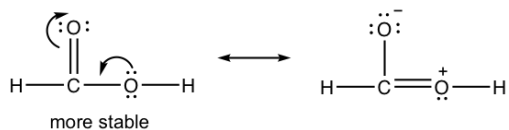

1.8

- What is the hybridization of oxygen atom in H₂O molecule?

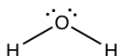

four electron groups around central oxygen (2 BP, 2 LP),
the oxygen is in sp³ hybridization

- What is the hybridization of xenon atom in XeF₄ molecule, and what is the shape of the whole molecule?

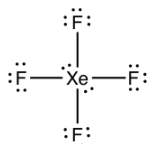

six electron groups around central oxygen (4 BP, 2 LP),
the oxygen is in sp³d² hybridization

This page titled [1.7: Answers to Practice Questions Chapter 1](#) is shared under a [CC BY-NC-SA 4.0](#) license and was authored, remixed, and/or curated by [Xin Liu \(Kwantlen Polytechnic University\)](#).

CHAPTER OVERVIEW

2: Fundamental of Organic Structures

- 2.1: Structures of Alkanes
- 2.2: Nomenclature of Alkanes
- 2.3: Functional Groups
- 2.4: IUPAC Naming of Organic Compounds with Functional Groups
- 2.5: Degree of Unsaturation/Index of Hydrogen Deficiency
- 2.6: Intermolecular Force and Physical Properties of Organic Compounds
- 2.7: Answers to Practice Questions Chapter 2

This page titled [2: Fundamental of Organic Structures](#) is shared under a [CC BY-NC-SA 4.0](#) license and was authored, remixed, and/or curated by [Xin Liu \(Kwantlen Polytechnic University\)](#).

2.1: Structures of Alkanes

2.1.1 Structures and Different Structure Formulas

Alkane is the simplest hydrocarbon with only C-C single bonds. The chain alkane fits the general formula of C_nH_{2n+2} (n : positive integer), and the number of H atoms reaches the maximum level in chain alkanes. The names and structures of straight-chain alkanes up to ten carbons are listed in the table below.

Number of Carbons	Name	Formula (C_nH_{2n+2})	Condensed Structure
1	methane	CH ₄	CH ₄
2	ethane	C ₂ H ₆	CH ₃ CH ₃
3	propane	C ₃ H ₈	CH ₃ CH ₂ CH ₃
4	butane	C ₄ H ₁₀	CH ₃ CH ₂ CH ₂ CH ₃
5	pentane	C ₅ H ₁₂	CH ₃ CH ₂ CH ₂ CH ₂ CH ₃
6	hexane	C ₆ H ₁₄	CH ₃ CH ₂ CH ₂ CH ₂ CH ₂ CH ₃
7	heptane	C ₇ H ₁₆	CH ₃ CH ₂ CH ₂ CH ₂ CH ₂ CH ₂ CH ₃
8	octane	C ₈ H ₁₈	CH ₃ CH ₂ CH ₂ CH ₂ CH ₂ CH ₂ CH ₂ CH ₃
9	nonane	C ₉ H ₂₀	CH ₃ CH ₂ CH ₂ CH ₂ CH ₂ CH ₂ CH ₂ CH ₂ CH ₃
10	decane	C ₁₀ H ₂₂	CH ₃ CH ₂ CH ₂ CH ₂ CH ₂ CH ₂ CH ₂ CH ₂ CH ₂ CH ₃

Table 2.1 Names and Structures of Straight-Chain Alkanes

The primary sources of alkanes are natural gas and petroleum. Natural gas contains mainly methane (70–90%) and some ethane. Petroleum refining separates crude oil into different fractions and each fraction consists of alkanes of similar number of carbons. Propane and butane are common fuels in propane gas burners and cigarette lighters. Alkanes with 5 to 8 carbons are the major components of gasoline, while diesel contains alkanes ranging from 9 to 16 carbons. As the number of carbons increase, the boiling point and viscosity of alkanes increase.

There are a variety of formats to show the structural formulas of organic compounds, it is important to be able to recognize different formula drawings, and use them correctly to represent the structures.

Kekulé Structure

We have had some discussions on Kekulé structures in **section 1.2.4**. They are similar to Lewis structures with all the bonding electrons shown in short lines and all the atoms included as element symbols. However, *the lone-pair electrons are left out* in Kekulé structures, which is the major difference between Kekulé structures of organic compound and Lewis structures.

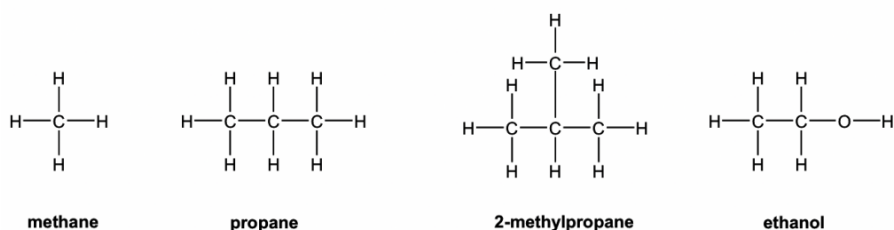

Figure 2.1a Examples of Kekulé Structures

Condensed Structure Formula

In **condensed structure formulas**, the C-H bonds are omitted and all the H atoms attached to a certain carbon (or other atoms) are usually shown as a group like CH₃, CH₂, NH₂, OH. The structures in **Table 2.1** are shown as condensed structures. The C-C bond sometimes can be omitted as well (as for 2-methylpropane and 2-hexanol in the examples below). Usually, if the structure has a branch, the bonding between the parent structure to the branch needs to be shown with a short line. It is faster to draw a structure with condensed structure formula, and the structure does not look as bulky as Kekulé structures.

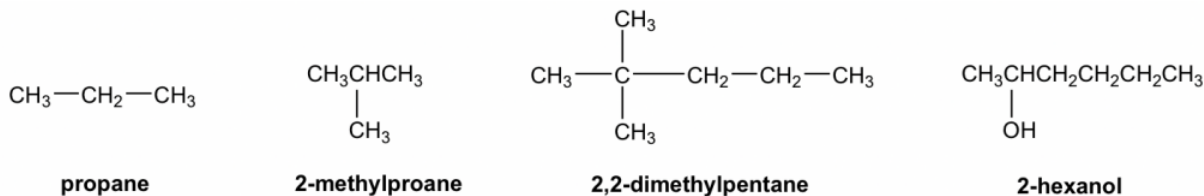
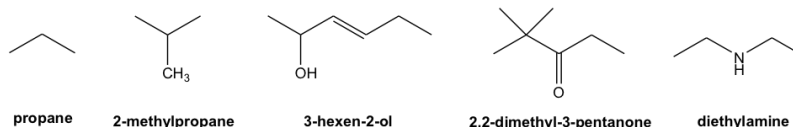

Figure 2.1b Examples of Condensed Structures

Short-Line Structure Formula

The structure drawing can be further simplified by short-line structure (or “bond-line structure”, “skeletal formula” in other books) with most atoms omitted, it is also the very common type of structure formula used in Organic Chemistry because of its simplicity. To apply and interpret the short-line structures correctly, it is very important to understand the conventions of this type of drawing clearly.

- Each short line represents a bond.
- The carbon chains are shown in a zig-zag way.
- No carbon atoms are shown (as an exception, it is optional to show the CH₃ group at the end of the chain, or as a branch); each **bend** in a line or **terminus** of a line represents a **carbon** atom, unless another atom is shown explicitly.
- Hydrogen atoms bonded to carbons are **not** shown; hydrogen atoms bonded to other atoms are shown explicitly.
- Atoms other than C and H, for example N, O, Cl, need to be shown explicitly.
-



Examples of Short-line Structures

Figure 2.1c Examples of Short-line structures

In short-line structures, the number of hydrogen atoms attached to each carbon can be calculated by applying the octet rule and checking formal charges involved.

Perspective Formula of 3D Structure

When it is necessary to highlight the spatial arrangement of groups around a tetrahedral sp³ carbon for conformation (Chapter 4) or stereochemistry (Chapter 5) purposes, the **perspective formula** with solid and dashed wedges are used. Out of the four bonds on a tetrahedral carbon, two bonds lie within the paper plane and are shown as ordinary lines, the solid wedge represents a bond that points out of the paper plane, and the dashed wedge represents a bond that points behind the paper plane.

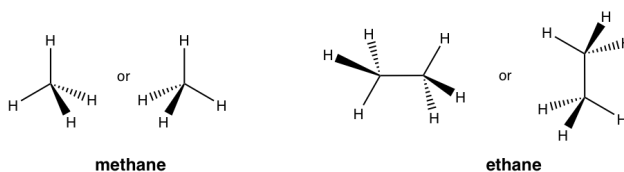

Figure 1.2d Examples of Perspective Formula

2.1.2 Constitutional Isomers

For methane, ethane and propane, there is only one way of carbon arrangement. As the number of carbon increases to 4 carbons, there are **two** ways for the carbon atoms to be connected, one as a straight-chain (blue structure below), and the other one as a

branch on the chain (red structure below).

Two Constitutional Isomers with Formula C_4H_{10}

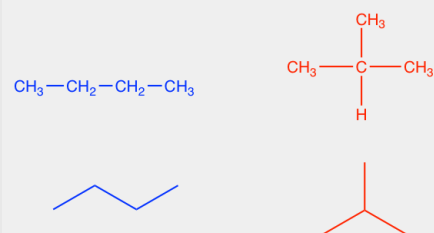

Butane

Isobutane (i-butane)
“iso” means “isomeric”

b.p. = 0 °C

b.p. = -12 °C

density: 0.622 g/mL

density: 0.604 g/mL

As we can see, these two different structures represent two different compounds, with different names and different physical properties; however, they both have the same formula of C_4H_{10} , and they are called Constitutional (Structural) isomers. **Constitutional (Structural) isomers** are different compounds with the same molecular formula, but their atoms arranged in a different order. (i.e. the atoms are bonded in different ways.)

Let's see more examples of constitutional isomers.

For alkanes with 5 carbons, there are a total of three constitutional isomers. Check the notes besides for the strategy to build constitutional isomers.

Constitutional isomers of C_5H_{12}

Isomer I

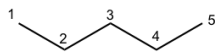

The basic one, with carbons connected one after the other.

Isomer II

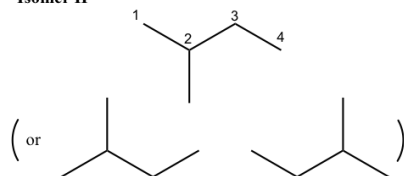

“Chop” one carbon off the basic chain, so the backbone has only 4 carbons. Then put the chopped carbon back, it has to be connected on the middle carbon in order to give a new structure.
Attention: the drawings in parentheses are for the same structure of Isomer II.

Isomer III

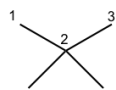

“Chop” two carbons off, so the backbone has only 3 carbons. To put the two carbons back, they both should be connected on the same carbon in order to give a new structure.

Figure 2.1e Constitutional isomers of C_5H_{12}

For alkanes with 6 carbons, there are a total of five constitutional isomers.

Constitutional isomers of C_6H_{14}

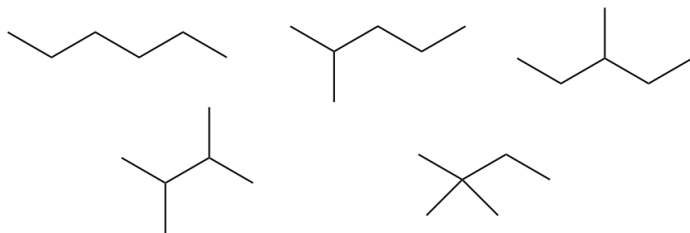

Exercises 2.1

Draw all the constitutional isomers with a formula of C_7H_{16} .

Answers to Practice Questions Chapter 2

The constitutional isomers we have so far have different lengths of carbon “backbones”, and are also called **skeletal constitutional isomers**. The other possible situations include **positional** and **functional constitutional isomers** that we will encounter later.

As the number of carbons increase, the number of constitutional isomers increases dramatically. For the example of alkanes with 20 carbons, that is $C_{20}H_{42}$, there are 366,319 constitutional isomers. While there is no simple formula allowing us to predict the total number of isomers for a certain amount of carbons, the phenomena of constitutional isomers partially explains the high diversity of organic structures.

2.1.3 Recognition of 1° , 2° , 3° , 4° carbons

The carbon atoms in organic structure can be categorized as primary (1°), secondary (2°), tertiary (3°) and quaternary (4°), depending on how many other carbons it connects with. Specifically:

- Primary (1°) carbon: attached directly to only one other C atom;
- Secondary (2°) carbon: attached directly to two other C atoms;
- Tertiary (3°) carbon: attached directly to three other C atoms;
- Quaternary (4°) carbon: attached to four other C atoms.

The hydrogen atoms attached on 1° , 2° and 3° carbon, are labeled as 1° , 2° and 3° hydrogen respectively.

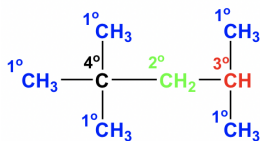

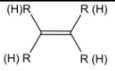



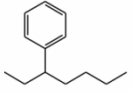

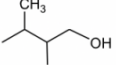

Figure 2.1f Hydrogen atoms attached on 1° , 2° and 3° carbon

In one compound, carbons (or hydrogens) that belong to different category show different structural and reactive properties. This concept has a lot more applications in later sections.

This page titled [2.1: Structures of Alkanes](#) is shared under a [CC BY-NC-SA 4.0](#) license and was authored, remixed, and/or curated by [Xin Liu \(Kwantlen Polytechnic University\)](#).

2.3: Functional Groups

Functional groups are the most reactive parts in organic compounds, and determine the major properties of compounds. The summary of common functional groups is included in **Table 2.2**. Knowing the functional groups well is one of the fundamental skills required for this course. It is required in order for students to quickly identify and name the functional groups included in molecules, as well as to understand, interpret and draw the specific structure of each functional group clearly. The IUPAC naming of compounds containing a couple of functional groups is required as well.

Class of Compounds	General Structure*	Specific Example	Notes
Alkene			
Alkyne			
Aromatic ring			
Alkyl halide (Haloalkane)	R-X X: F, Cl, Br or I		R-CH ₂ -X: 1° halide R ₂ -CH-X: 2° halide R ₃ -C-X: 3° halide
Alcohol	R-OH		R-CH ₂ -OH: 1° alcohol R ₂ -CH-OH: 2° alcohol R ₃ -C-OH: 3° alcohol
Ether	R-O-R'	CH ₃ -O-CH ₂ CH ₃ ethyl methyl ether (common name)	Common name:** Alkyl alkyl ether (alphabetic order)
Nitrile	R-C≡N	H ₃ C-C≡N	
Nitro	R-NO ₂		
Amine	RNH ₂ R ₂ NH R ₃ N	CH ₃ CH ₂ NH ₂ : ethyl amine (common name) (CH ₃ CH ₂) ₃ N: triethyl amine (common name)	Common name:** Alkyl alkyl alkyl amine (alphabetic order)

* R: hydrocarbon group, alkyl or phenyl; for structure with multiple R, they can be same or different groups.

** These common names are accepted by IUPAC.

Figure 2.3a Table 2.2 Common Organic Functional Groups

Class of Compounds	General Structure	Specific Example	Notes
Aldehyde	$\text{R}-\overset{\text{O}}{\parallel}{\text{C}}-\text{H}$ or: R-CHO		C=O double bond is usually called as a "carbonyl" group. The function groups on this page all contain carbonyl group.
Ketone	$\text{R}-\overset{\text{O}}{\parallel}{\text{C}}-\text{R}(\text{R}')$		
Carboxylic acid	$\text{R}-\overset{\text{O}}{\parallel}{\text{C}}-\text{OH}$ or: R-COOH	$\text{CH}_3\text{CH}_2-\overset{\text{O}}{\parallel}{\text{C}}-\text{OH}$	Reaction with base gives salt of carboxylic acid, $\text{RCOO}^- \text{M}^+$
Ester	$\text{R}-\overset{\text{O}}{\parallel}{\text{C}}-\text{OR}(\text{R}')$	$\text{CH}_3\text{CH}_2-\overset{\text{O}}{\parallel}{\text{C}}-\text{OCH}_3$	Carboxylic acid derivative.
Anhydride	$\text{R}-\overset{\text{O}}{\parallel}{\text{C}}-\text{O}-\overset{\text{O}}{\parallel}{\text{C}}-\text{R}(\text{R}')$	$\text{H}_3\text{C}-\overset{\text{O}}{\parallel}{\text{C}}-\text{O}-\overset{\text{O}}{\parallel}{\text{C}}-\text{CH}_3$	Carboxylic acid derivative.
Amide	$\text{R}-\overset{\text{O}}{\parallel}{\text{C}}-\text{N}(\text{R}'(\text{H}))_2$		Carboxylic acid derivative

Figure 2.3b Table 2.2 Common Organic Functional Groups (continued)

Alkene and alkynes are hydrocarbon functional groups; the π bond in multiple bonds accounts for the reactivity of alkenes and alkynes.

Benzene rings (C_6H_6) are a special type of hydrocarbon. Historically, because of the special aroma (sweet smelling) that benzene and its derivatives release, they are called aromatic compounds. The structure of benzene can be represented as three C=C double bonds alternate with single bonds, however, the actual structure of benzene has nothing to do with alkenes. Detailed discussions on the structure of benzene, which is a big conjugation system, and the chemistry definitions of aromatic/aromaticity will be a topic of Organic Chemistry II. Benzene rings can be shown with any of the following structure drawings.

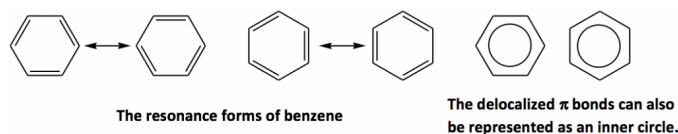

Figure 2.3c Benzene

When a halogen is connected with carbon, the group is called **alkyl halide (or haloalkane)**. The halide can be categorized as a primary (1°), secondary (2°) or tertiary (3°) halide, depending on what category the carbon connected with the halogen is in.

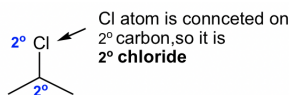

Figure 2.3d Chloride on 2° carbon

Alcohol is a functional group that you probably are familiar with. In organic chemistry, the term alcohol refers to a compound containing the OH (hydroxy) group. Depending on the position of the OH group, alcohols can also be categorized as primary (1°), secondary (2°) or tertiary (3°).

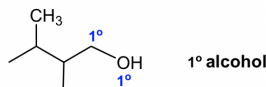
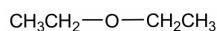

Figure 2.3e 1° alcohol

Another functional group that contains the oxygen atom in single bonds is **ether**. In ether, the O atom connects with two carbon-containing R groups through two C-O σ bonds. For compounds with ether as the only functional group, it is usually named with the common name "alkyl alkyl ether". When the two alkyl groups are the same, they can be combined as "dialkyl".



diethyl ether

Figure 2.3f diethyl ether

Ether can be in cyclic structure as well. It may not be that intuitive to recognize the following structure as ether, and labelling the carbon atom will be helpful for identification.

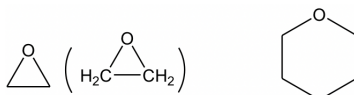

cyclic ether examples

Figure 2.3g Cyclic ether examples

Both **nitrile** and **nitro** groups contain nitrogen atom, and it might be easy to get them mixed up. Nitrile has a C≡N triple bond, and therefore can only be at the end of a structure, while nitro (NO₂) can be in any position on the carbon chain or ring.

Amine is the organic derivative of ammonia, NH₃. When the hydrogen atom(s) in NH₃ is replaced with R groups, it produces amine. The amine can be primary (1°), secondary (2°) or tertiary (3°) depending on how many R groups are connected with nitrogen. The amines can also be named with common names.

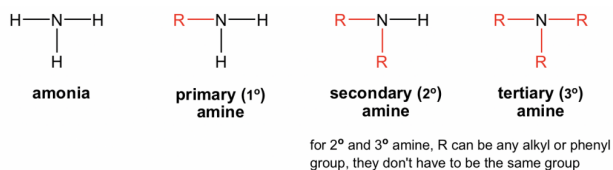

Figure 2.3h Primary, secondary, & tertiary amine

For the functional groups on the 2nd part of **Table 2.2**, they all have a common structural unit of a carbonyl group C=O; the different structure of “W” in the general formula determines the nature of the functional group. It is usually more challenging to identify and draw these functional groups correctly, because they are kind of similar. More practice is needed.



General structure of functional groups containing C=O bond

Figure 2.3i General structure of functional groups containing c=o bond

Aldehyde and **ketone** are similar in terms of their structures and properties. Aldehyde can be regarded as a special case of ketone since “H” can be regarded as an R with zero carbon. Because H has to be connected on one side of the C=O group in aldehyde, aldehyde can only be at the end of a structure. Ketone, on the other hand, must be in the middle position to ensure both sides of the C=O groups are connected with R groups. Ketone can also be in a cyclic structure.

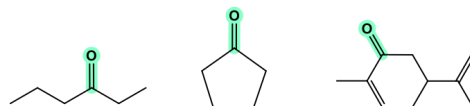
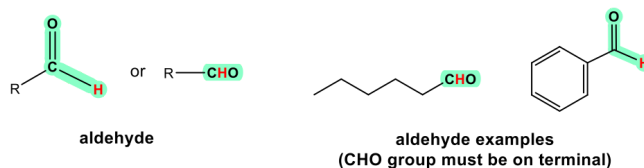

ketone and cyclic ketone examples

Figure 2.3j Ketone and cyclic ketone examples

The last four functional groups are related in terms of structures and chemical properties. When an OH group is connected with C=O, the whole COOH is called a **carboxylic acid** functional group. The other three, **ester**, **anhydride** and **amide**, are all *derivatives* of carboxylic acid, meaning they can be prepared with carboxylic acid as the starting material. For these three

functional groups, it is important to remember that the “W” part has to be considered together with the C=O, and overall it determines the functional group correctly. For example, the COOR is ester; it **can not** be recognized as a “ketone” plus an “ether”.

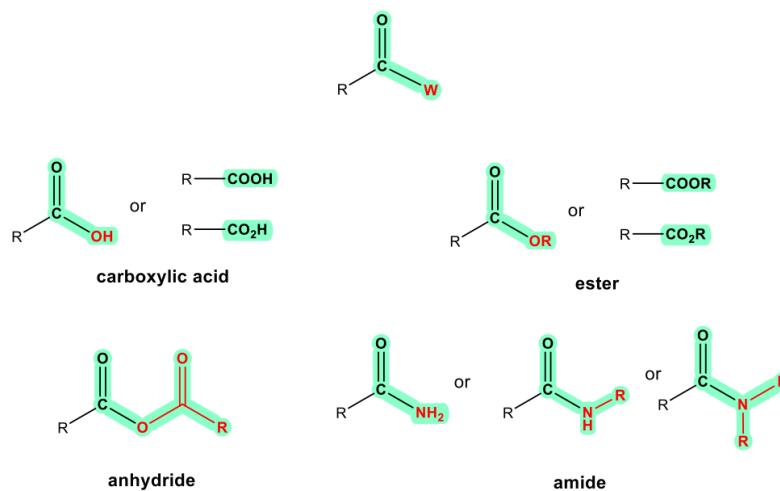

Figure 2.3k Carboxylic acid (COOH/CO₂H), ester (COOR/CO₂R), anhydride, & amide

This page titled [2.3: Functional Groups](#) is shared under a [CC BY-NC-SA 4.0](#) license and was authored, remixed, and/or curated by [Xin Liu](#) (Kwantlen Polytechnic University).

2.4: IUPAC Naming of Organic Compounds with Functional Groups

With the ability to identify functional groups, next we will learn how to give IUPAC names to compounds containing a few functional groups, by following a set of rules.

IUPAC NOMENCLATURE of COMPOUNDS with FUNCTIONAL GROUPS

1. Find the longest carbon chain containing the functional group with highest priority (see **Table 2.3**). This chain determines the *parent name* of the compound.
2. Change the ending of the parent alkane/alkene/alkyne to the *suffix* of the highest priority group, which gives the parent name of the compound (usually, drop the last letter “e” before adding the suffix, except for nitrile where the “e” is kept).
3. Number the chain from the end closest to the highest functional group.
4. The other groups are named as substituents by using the appropriate *prefixes*.
5. Assign stereochemistry, E/Z or R/S, as necessary (details in **Chapter 5**).

For naming purposes, the functional groups are assigned with priorities (Table 2.3). If the compound includes more than one functional groups, the one with the **highest** priority is the “parent structure” and determines the “parent name”; the other groups will be regarded as “substituents”. “Suffix” is used to indicate the name of the parent structure, and “prefix” is for the substituent. The order of the groups listed in **Table 2.3** is based on the *decreasing* order of the priority, where carboxylic acid group is in the highest priority. The groups in the subordinate table have no difference in terms of priority, and they are usually listed in the alphabetic order.



Functional group	Prefix	Suffix	Examples	Name of Example
carboxylic acid	carboxy	-oic acid -carboxylic acid		pentanoic acid
acid anhydride	—	-oic anhydride -carboxylic anhydride		ethanoic anhydride
carboxylic ester	alkoxycarbonyl	-oate -carboxylate	$\text{CH}_3\text{CH}_2\text{C}(=\text{O})\text{OCH}_3$ 	methyl propanoate
amide	amido	-amide -carboxamide		N-propylethanamide
nitrile	cyano	-nitrile (keep “e”) -carbonitrile		butanenitrile
aldehyde	oxo	-al -carbaldehyde		4-bromo-pentanal
ketone	oxo	-one		3-hexanone
alcohol	hydroxy	-ol		3-methyl-2-butanol
amine	amino	-amine		butylamine (common name)

Table 2.3 Naming Priorities of

Common Functional Groups

Functional group	Structure	Prefix	Suffix
alkyl halide	R—X (X: F, Br, Cl, I)	halo (fluoro, bromo, chloro, iodo)	—
ether	R—O—R	oxy	ether
sulfide	R—S—R	alkylthio	sulfide
nitro	—NO ₂	nitro	—
benzene		phenyl	benzene

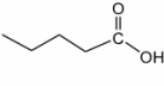
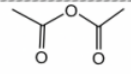
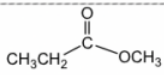
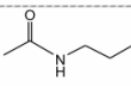
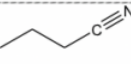
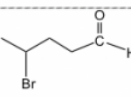
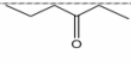
Table 2.4 Subordinate Groups

We will go through several examples for more details about the naming rules.

1.

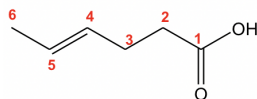

The parent structure is the 6-carbon carboxylic acid with a double bond, so the last name comes from “hexene”. To add the suffix, the last letter “e” will be dropped, so the parent name is “hexeneoic acid”. A number is necessary to indicate the position of the double bond, so the name is “4-hexenoic acid”. The carboxylic acid group is always on the #1 position, so it is NOT necessary to include that number for the position.

2.

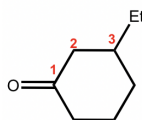

This is a ketone based on a cycloalkane, so the last name comes from “cyclohexane”. By adding the suffix, it becomes “cyclohexanone”, and the complete name is “3-ethylcyclohexanone”.

3.

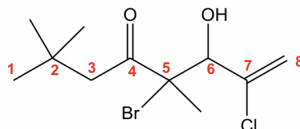

With the multiple groups involved, the ketone has the highest priority, so it decides the last name. The 8-carbon alkene chain with ketone should be named as “octenone”. The numbers on the chain should start from the left side to ensure that the ketone has the lowest number. When the OH group is regarded as a substituent, it is indicated by the prefix “hydroxy”. So the complete name is “5-bromo-7-chloro-6-hydroxy-2,2,5-trimethyl-7-octen-4-one”.

4.

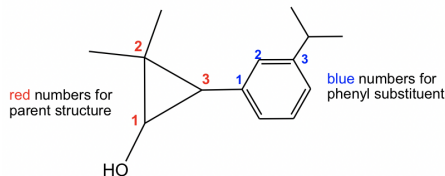

It is not difficult to find the parent structure for this compound, which is a cyclic alcohol, so the last name is “cyclopropanol”. The naming of the substituent with the benzene ring is a bit challenging. When benzene is a “substituent”, it is called “phenyl”; and since

there is an isopropyl group on the “phenyl”, the whole substituent is called “3-isopropylphenyl”, and the complete name of the compound is “2,2-dimethyl-3-(3-isopropylphenyl)cyclopropanol”.

5.

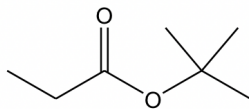

In ester, an OR group replaces the OH group of a carboxylic acid. When naming the ester, the name of the R in the OR group is stated first, followed by the name of the acid, with “oic acid” replaced by “oate”. As a net result, the R in the OR is regarded as the “substituent”, even though it is not. So, the complete name of the ester above is “*tert*-butyl propanoate”.

Naming of substituted benzene and benzene derivatives

For substituted benzene, the benzene ring is regarded as the parent structure, and the positions and names of substituents are added to the front.

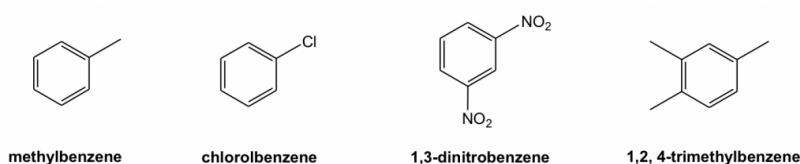
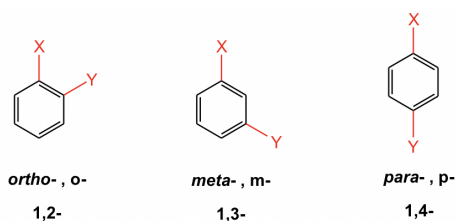

Figure 2.4a Methylbenzene, chlorobenzene, 1,3-dinitrobenzene, & 1,2,4-trimethylbenzene

For di-substituted benzene, there is another unique way to indicate the relative position of the two substituents by using ortho-, meta- and para-. Although this o-, m-, p- system is the common naming system for benzene derivatives, they have been applied broadly in books and literatures.

- **ortho- (o-):** 1,2- (next to each other in a benzene ring)
- **meta- (m):** 1,3- (separated by one carbon in a benzene ring)
- **para- (p):** 1,4- (across from each other in a benzene ring)



For the following mono-substituted benzene derivatives, phenol, benzoic acid and benzaldehyde, their common names are adopted in the IUPAC system.

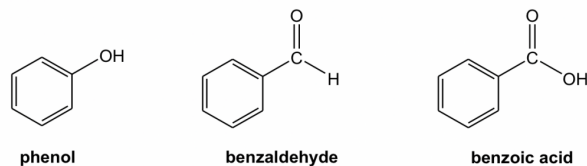
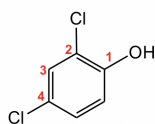

Figure 2.4b Phenol, benzaldehyde, benzoic acid

When other substituents are introduced into those benzene derivatives, the common name will be used as the parent name of the compound with the *base* functional group (OH for phenol, COOH for benzoic acid and CHO for benzaldehyde) given the #1 position. For example:



2,4-dichlorophenol

Figure 2.4c 2,4-dichlorophenol

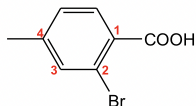

2-bromo-4-methylbenzoic acid

Figure 2.4d 2-bromo-4-methylbenzoic acid

When benzene is connected to a carbon chain that does not contain any higher priority group, benzene is the parent, even if the carbon chain contains more than six carbons. For example, the following compound is heptylbenzene, although the heptyl group has more carbons than benzene.

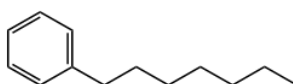

Heptylbenzene

Figure 2.4e 2-heptanebenzene

This page titled [2.4: IUPAC Naming of Organic Compounds with Functional Groups](#) is shared under a [CC BY-NC-SA 4.0](#) license and was authored, remixed, and/or curated by [Xin Liu](#) (Kwantlen Polytechnic University).

2.5: Degree of Unsaturation/Index of Hydrogen Deficiency

Now with lots functional groups introduced, the extent of constitutional isomers will be expanded a lot. To further explore the phenomena of constitutional isomers, we will need to understand the concept of **Degree of Unsaturation** (or: **Index of Hydrogen Deficiency/IHD**).

Let's compare three compounds first: pentane, 1-pentene and cyclopentane

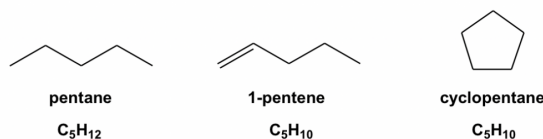

Figure 2.5a Pentane, 1-pentene, & cyclopentane

The formula for pentane is C_5H_{12} . For a compound containing 5 carbons, the *maximum* number of hydrogens is 12, so the structure of pentane is **saturated** (no more hydrogen atoms can be added in), or we can say that pentane has **zero degree of unsaturation**.

For 1-pentene C_5H_{10} , there are *two less* hydrogens than the saturated level (pentane), which means the 1-pentene has **one degree of unsaturation**. With a ring introduced, cyclopentane (C_5H_{10}) also has to sacrifice *two* hydrogens, so cyclopentane also has **one degree of unsaturation**. The trend is that when a double bond (essentially a π bond), or a ring, is involved in the structure, it leads to one degree of unsaturation of the compound.

Formula	Degree of Unsaturation/ Index of Hydrogen Deficiency (IHD)*	Structure Unit Involved
C_nH_{2n+2}	0	chain alkane only
C_nH_{2n}	1	1 double bond or 1 ring
C_nH_{2n-2}	2	2 double bonds or 2 rings or 1 double bond plus 1 ring or 1 triple bond

Table 2.5 Summary of degree of unsaturation/IHD vs structure unit involved

The degree of unsaturation could be accumulated, and **Table 2.5** summarizes the situations up to two degrees. As we can see, adding 1 ring or 1 π bond contributes to one degree of unsaturation. Therefore, the essential meaning of degree of unsaturation is the “number of **rings plus π bonds**” in a structure.

If the structure of a compound is available to us, the total degrees of unsaturation can simply be counted through inspecting the structure.

Example:

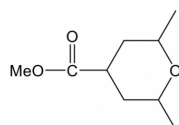

This compound has one ring and one double bond, so the total degree of unsaturation is 2.

Figure 2.5b Total degree of unsaturation is 2

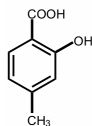

Benzene ring means 4 unsaturation degrees (3 double bonds and 1 ring); COOH also include one C=O bond. Total degree of unsaturation is 5.

Figure 2.5c Total degree of unsaturation is 5

If the formula of a compound is given, we can also calculate the degree of unsaturation by comparing the number of hydrogens vs the saturated level, by using the equation:

$$\text{Degree of unsaturation} = \frac{(2n+2)-X}{2} \quad (\text{n: number of carbons; X = number of H + number of Halogen - number of N})$$

This is a general equation that accounts for the presence of heteroatoms as well. Please note that oxygen atoms are ignored in this calculation.

For example, for a compound with a formula given as C_4H_7NO , it is calculated that the degree of unsaturation is 2 for this compound: $\frac{(2n+2)-X}{2} = \frac{(2 \times 4 + 2) - (7 - 1)}{2} = 2$

Now we are ready to solve constitutional isomer questions with the application of degrees of unsaturation. Usually, the formula information is available to us for such questions, and we will need to build constitutional isomers based on the given formula together with other requirements. To solve this type of question, it is very helpful to do it strategically by following certain steps:

- Calculate the degree of unsaturation based on the given formula.
- With the value of this specific unsaturation degree, how many double bonds or rings might be included in the structure?
- Combine your knowledge of functional groups with the degree of unsaturation, as well with certain atoms included in the formula, to see what functional group(s) may be possible.
- Build constitutional isomers according to the above information (separate the isomers by different functional group).

410 Examples: Draw and name all the constitutional isomers with the molecular formula CHO .

Approach: Answering the following questions lead you to the solution.

- What is the degree of unsaturation for the formula $C_4H_{10}O$? **0**
- How many double bonds, or rings, could be involved? **none**
- What are the possible functional groups that matche with that degree of unsaturation, and include one oxygen atom? **alcohol or ether**
- With these hints, we can try to “build” the constitutional isomers for each functional group separately. **total seven structures**

Solutions:

alcohols:

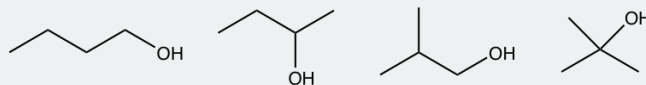

ethers:

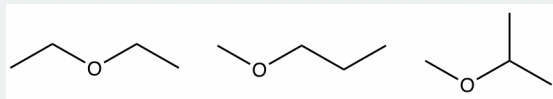

Exercises 2.2

Draw all the constitutional isomers that include a C=O bond with formula the $C_5H_{10}O$.

[Answers to Practice Questions Chapter 2](#)

This page titled [2.5: Degree of Unsaturation/Index of Hydrogen Deficiency](#) is shared under a [CC BY-NC-SA 4.0](#) license and was authored, remixed, and/or curated by [Xin Liu \(Kwantlen Polytechnic University\)](#).

2.6: Intermolecular Force and Physical Properties of Organic Compounds

2.6.1 Intermolecular Forces

In Organic Chemistry, the understanding of physical properties of organic compounds, for instance boiling point (b.p.), molecular polarity and solubility, is very important. It provides us with helpful information about dealing with a substance in the proper way. Those physical properties are essentially determined by the intermolecular forces involved. **Intermolecular forces** are the attractive force **between** molecules and that hold the molecules together; it is an electrical force in nature. We will focus on three types of intermolecular forces: dispersion forces, dipole-dipole forces and hydrogen bonds.

Dispersion Forces

Dispersion Forces (also called London Forces) result from the instantaneous dipole and induced dipole of the molecules. For nonpolar molecules, the constant shifting and distortion of electron density leads to a weak short-lived dipole at a given moment, which is called an instantaneous dipole. Such temporary dipoles will induce the electrons in a neighbouring molecule to get distorted as well, and to develop a corresponding transient dipole of its own, which is the induced dipole. At the end, all nonpolar molecules are attracted together via the two types of temporary dipoles as shown in **Fig. 2.6a**. The dispersion force is weak in nature, and is the weakest intermolecular force. However, since it applies to all types of molecules (it is the only intermolecular force for nonpolar molecules), dispersion forces are also the most fundamental intermolecular force.

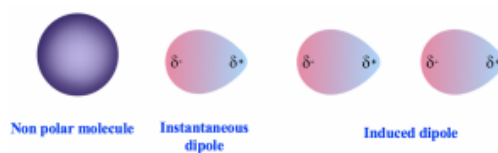

Figure 2.6a Instantaneous Dipole and Induced Dipole

The magnitude of dispersion forces depends on two factors:

- The relative **polarizability** of electrons. The simple understanding of polarizability is how easily the electrons get distorted. For larger atoms, there are more electrons in a larger space, therefore the electrons are more loosely held and more easily polarized, so the dispersion force is stronger. Generally, the larger the molar mass of the molecule, the stronger the dispersion force.
- The relative **surface area** of the molecule. Molecules with longer, flatter or cylindrical shapes have a greater surface area compared to the bulky, branched molecules, and therefore have a stronger dispersion force. Taking the two constitutional isomers of C_4H_{10} (**section 2.1.2**), butane and isobutane as an example, the dispersion force of butane is stronger than that of isobutane.
-

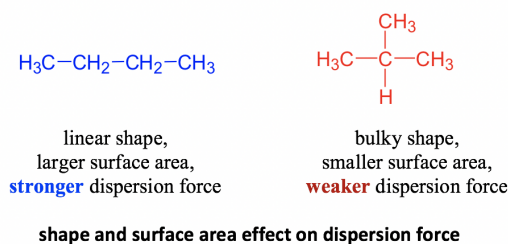
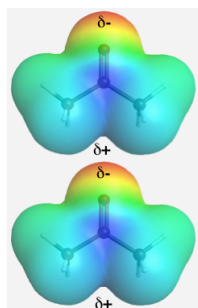

Figure 2.6b Shape and surface area effect on dispersion force

Dipole-Dipole Force

For polar molecules, molecules are attracted to each other because of a permanent dipole, and this type of attractive force is called a dipole-dipole force. As shown below in the electrostatic potential map of acetone, one end of acetone has a partial negative charge (red) and the other end has a partial positive charge (blue). The dipole-dipole force is an attraction force between the positive end of one molecule and the negative end of the neighbouring molecule.



electrostatic potential map of acetone
Figure 2.6c Electrostatic potential map of acetone

Hydrogen Bonds

First of all, do not let the name mislead you! Although it is called a “bond”, a hydrogen bond is not a covalent bond, it is a type of intermolecular force. The hydrogen bond is the force between a H atom that is bonded to O, N or F (atoms with high electronegativity) and the neighbouring electronegative atom,. It can be shown in a general way as:

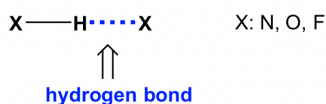

Figure 2.6d Hydrogen bond

The most common example of hydrogen bonding is for water molecules. Water has two O-H bonds, and both are available as hydrogen bond donors for neighbouring molecules. This explains the extraordinarily high b.p. of water (100 °C), considering the rather small molar mass of 18.0 g/mol. As a comparison, the methane molecule CH₄ with a similar size has a b.p. of -167.7 °C.

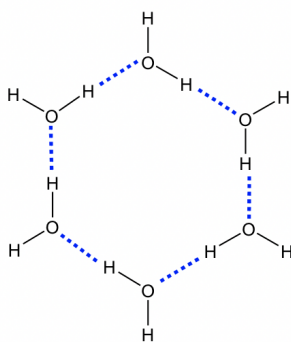

Figure 2.6e Simplified Diagram of Hydrogen Bonds between Water Molecules

For organic compounds, hydrogen bonds play important roles in determining the properties of compounds with OH or NH bonds, for example alcohol (R-OH), carboxylic acid (R-COOH), amine (R-NH₂) and amide RCONH₂.

The three major types of intermolecular forces are summarized and compared in **Table 2.6**.

Type of Force	Applied to	Strength
Dispersion Forces	All molecules	0.1 – 5 kJ/mol
Dipolar Forces	Polar molecules	5 – 20 kJ/mol
Hydrogen Bonding	Polar molecules with N – H, O – H or F – H bond	5 – 50 kJ/mol

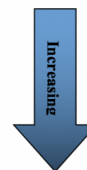

Table 2.6 Summary of the Three Major Intermolecular Forces

Table 2.6 Summary of the Three Major Intermolecular Forces

Polar vs Non-Polar molecules

As indicated in **Table 2.6**, the nature of molecular polarity determines the types of force(s) applied to a certain substance. So here we will have discussions about how to tell whether a molecule is polar or non-polar.

The polarity of the compound can be determined by its formula and shape.

For **diatomic molecules**, the molecular polarity is the same as the bonding polarity. That means all homonuclear molecules, like H_2 , N_2 , O_2 , F_2 , are non-polar because of their non-polar bond, while all heteronuclear molecules, like HF, HCl, are polar.

For **polyatomic molecules**, the molecular polarity depends on the shape (refer to VSEPR in **Section 1.5**) of the molecule as well. Let's see the examples of H_2O and CO_2 .

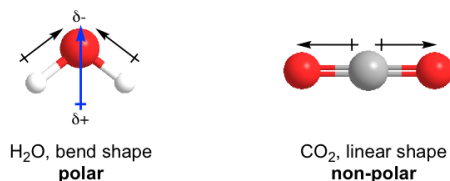

Figure 2.6f Polar and non-polar

Both H_2O and CO_2 have two polar bonds. H_2O is in the bent shape, so the bond polarities of the two O-H bonds add up to give the molecular polarity of the whole molecule (shown above), therefore H_2O is polar molecule. On the other hand, the shape of CO_2 is linear, and the bond polarities of the two C=O bonds cancel out, so the whole CO_2 molecule is non-polar.

There are other examples of non-polar molecules where the bond polarity cancels out, such as BF_3 , CCl_4 , PCl_5 , XeO_4 etc.

For organic compounds, the hydrocarbons (C_xH_y) are always non-polar. This is mainly because of the small electronegativity difference between carbon atoms and hydrogen atoms, making C-H bonds technically non-polar bonds.

For other organic compounds that contain functional groups with heteroatoms, like R-O-R, C=O, OH, NH, they are all polar molecules.

The diagram here (**Fig. 2.6g**) provides a summary of all the discussions about molecular polarities.

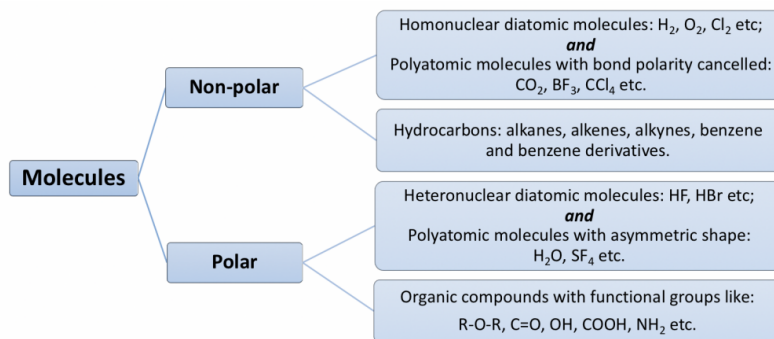

Figure 2.6g Summary of Molecular Polarities

Other than the three types of intermolecular forces, there is another interaction that is very important for understanding the physical property of a compound, which is the ion-dipole force.

Ion-Dipole Force

Ion-dipole force is not categorized as an intermolecular force, however it is a type of important non-covalent force that is responsible for the interaction between ions and other polar substance. A simple example is the dissolving of an ionic solid, or salt, in water. When table salt ($NaCl$) is dissolved in water, the interactions between the ions and water molecules are strong enough to overcome the ionic bond that holds the ions in the crystal lattice. As a result, the cations and anions are separated apart completely, and each ion is surrounded by a cluster of water molecules. This is called a **solvation** process. The solvation occurs through the strong ion-dipole force. Lots salts, or ionic compounds, are soluble in water because of such interactions.

2.6.2 Physical Properties and Intermolecular Forces

The comprehension of intermolecular forces helps us to understand and explain the physical properties of substances, since it is intermolecular forces that account for physical properties such as phases, boiling points, melting points, viscosities, etc. For organic chemistry purposes, we will focus on boiling point (b.p.) and solubility.

Boiling point (b.p.):

The boiling point trend of different substance directly correlates with the total intermolecular forces. Generally speaking, the stronger the overall intermolecular force applied to a certain substance, the higher the boiling point of the substance. Boiling point is the temperature at which the liquid phase of the substance vaporizes to become a gas. In order to vaporize a liquid, the intermolecular forces that hold the molecules together must be overcome. The stronger the forces, the more energy is needed to overcome the forces, and a higher temperature is required, thus leading to a higher boiling point.

Example:

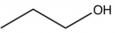
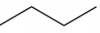
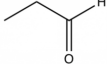
		
propanol	butane	propanal
b.p.: 97 °C	-0.5 °C	48 °C
MM: 60 (g/mol)	58	58

All three compounds here have similar Molar Masses, so the dispersion forces are at a similar level. However, the three compounds have different molecular polarities. Butane is a non-polar substance that only has dispersion forces, propanal is a polar molecule with both dispersion forces and dipole-dipole forces, and propanol is a polar molecule with an OH bond, so all three types of forces apply to. Therefore, the overall amount of intermolecular forces is strongest for propanol, and weakest for butane, which is in the same order as their boiling points.

Solubility:

A general rule for solubility is summarized by the expression “like dissolves like”. This means that one substance can dissolve in another with similar polarity, and as a result, with similar intermolecular forces. More specifically:

- Nonpolar substances are usually soluble in nonpolar solvents.
- Polar and ionic substances are usually soluble in polar solvents.
- Polar and nonpolar substances are insoluble to each other.

Determining the polarity of a substance has already been summarized in an earlier part of this section (**Fig. 2.6g**). Water, methanol and ethanol are examples of very polar solvents that can form Hydrogen bonds. Ether, ketone, halide and esters are polar solvents as well, but not as polar as water or methanol. Non-polar solvents include hydrocarbons like hexane, benzene, toluene etc.

For some organic compounds, however, it may not be that easy to simply call it polar or non-polar, because part of the compound may be polar, and the another part may be nonpolar. This is often described as hydrophilic or hydrophobic.

- **Hydrophobic** (*hydro*, water; *phobic*: fearing or avoiding) meaning it does not like water, or is insoluble in water;
- **Hydrophilic** (*hydro*, water; *philic*: loving or seeking) meaning it likes water, or is soluble in water.

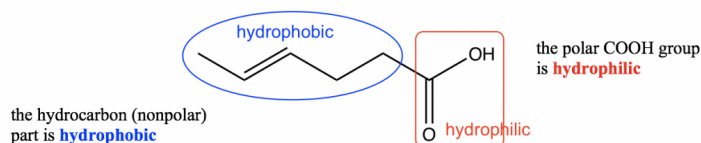

Figure 2.6h Hydrophobic and Hydrophilic

The hydrocarbon part of the organic compound is *hydrophobic*, because it is nonpolar and therefore does not dissolve in polar water. The functional group of OH, COOH, NH₂ etc is polar and is therefore *hydrophilic*. With both hydrophobic and hydrophilic parts present in an organic compound, the overall polarity depends on whichever part is the major one. If the carbon chain is short (1~3 carbons), the hydrophilic effect of the polar group is the major one, so the whole compound is soluble in water; with carbon chains of 4~5 carbons, the hydrophobic effect begins to overcome the hydrophilic effect, and water solubility is lost.

The solubility differences of different alcohols demonstrates this trend clearly; as the length of the carbon chain increases, the solubility of alcohol in water decreases dramatically (**Table 2.7**):

Alcohol	Solubility in water (g/100mL)
methanol, ethanol, propanol (CH ₃ OH, CH ₃ CH ₂ OH, CH ₃ CH ₂ CH ₂ OH)	miscible (dissolve in all proportions)
1-butanol (CH ₃ CH ₂ CH ₂ CH ₂ OH)	9
1-pentanol (CH ₃ CH ₂ CH ₂ CH ₂ CH ₂ OH)	2.7
1-octanol (CH ₃ CH ₂ CH ₂ CH ₂ CH ₂ CH ₂ CH ₂ CH ₂ OH)	0.06

Table 2.7 Solubility of different alcohols in water

For organic compounds that are water *insoluble*, they can sometimes be converted to the “salt derivative” via a proper reaction, and thus can become water soluble. This method is used commonly in labs for the separation of organic compounds.

Example:

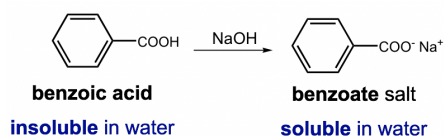

Figure 2.6i Convert insoluble organic compound to the soluble salt derivative

Applying acid-base reactions is the most common way to achieve such purposes. As shown in the above example, by adding a strong base to the benzoic acid, an acid-base reaction occurs and benzoic acid is converted to its salt, sodium benzoate, which is water soluble (because of the ion-dipole force as we learned earlier). The benzoic acid can therefore be brought into water (aqueous) phase, and separated from other organic compounds that do not have similar properties.

This page titled [2.6: Intermolecular Force and Physical Properties of Organic Compounds](#) is shared under a [CC BY-NC-SA 4.0](#) license and was authored, remixed, and/or curated by [Xin Liu \(Kwantlen Polytechnic University\)](#).

2.7: Answers to Practice Questions Chapter 2

2.1 Draw all the constitutional isomers with a formula of C_7H_{16}

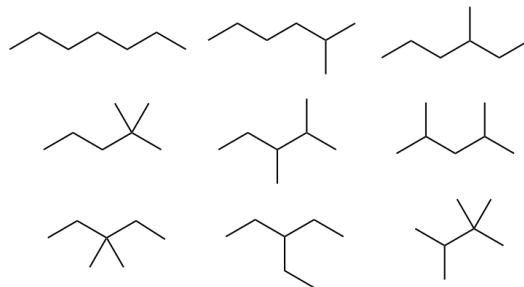

2.2 Draw all the constitutional isomers that include C=O bond with formula $C_5H_{10}O$.

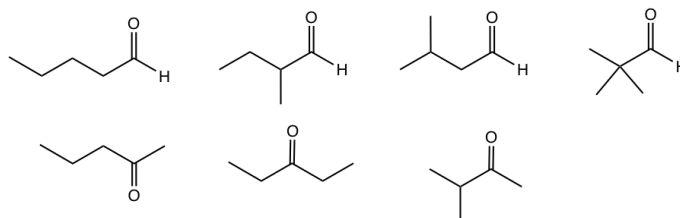

This page titled [2.7: Answers to Practice Questions Chapter 2](#) is shared under a [CC BY-NC-SA 4.0](#) license and was authored, remixed, and/or curated by [Xin Liu \(Kwantlen Polytechnic University\)](#).

CHAPTER OVERVIEW

3: Acids and Bases- Organic Reaction Mechanism Introduction

3.1: Review of Acids and Bases and K_a

3.2: Organic Acids and Bases and Organic Reaction Mechanism

3.3: pK_a of Organic Acids and Application of pK_a to Predict Acid-Base Reaction Outcome

3.4: Structural Effects on Acidity and Basicity

3.5: Lewis Acids and Lewis Bases

3.6: Answers to Practice Questions Chapter 3

This page titled [3: Acids and Bases- Organic Reaction Mechanism Introduction](#) is shared under a [CC BY-NC-SA 4.0](#) license and was authored, remixed, and/or curated by [Xin Liu \(Kwantlen Polytechnic University\)](#).

3.1: Review of Acids and Bases and Ka

15

The most commonly applied definition of acids and bases is the Brønsted-Lowry definition:

- **Brønsted-Lowry Acid:** a substance that can donate a proton (H^+);
- **Brønsted-Lowry Base:** a substance that can accept a proton (H^+).

Therefore, according to the Brønsted-Lowry definition, an acid-base reaction is a proton transfer process in which the acid gives away a proton and base accepts a proton as shown in the general equation:

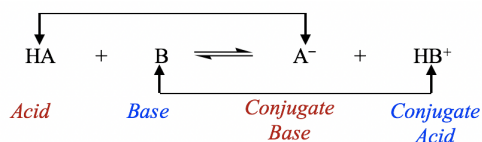

General equation for acid-base reaction

The species that forms when an acid loses its proton is called the **conjugate base** of that acid; similarly, the species that forms when a base accepts a proton is called the **conjugate acid** of that base. In the general equation above, HA is the conjugate acid of A^- , and A^- is the conjugate base of HA. HA and A^- can also be called a **conjugate acid-base pair**; another pair is HB^+ and B.

A strong acid donates the proton completely, and the arrow “ \rightarrow ” can be used in the reaction equation to indicate that the reaction goes to completion. The dissociation reaction of the strong acid HCl in water is used as an example here:

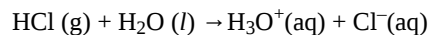

For weak acids (HA is used as a general formula), the proton is only donated partially and the reaction stays at equilibrium. The equilibrium arrow “ \rightleftharpoons ” will be needed in the reaction equation to indicate the equilibrium status:

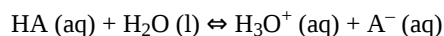

The equilibrium constant for the above reaction is called the **acid dissociation constant, K_a** . It is a constant to measure the relative strength of an acid. The expression for K_a is:

$$K_a = \frac{[\text{H}_3\text{O}^+][\text{A}^-]}{[\text{HA}]}$$

The larger the K_a value, the stronger the ability of the acid to donate protons, and the stronger the acid is. (Technically, when the K_a value is larger than 10, the acid can be regarded as a strong acid.)

For the conjugate acid-base pair, the stronger the acid, the weaker the conjugate base is, and vice versa.

This page titled [3.1: Review of Acids and Bases and Ka](#) is shared under a [CC BY-NC-SA 4.0](#) license and was authored, remixed, and/or curated by [Xin Liu \(Kwantlen Polytechnic University\)](#).

3.2: Organic Acids and Bases and Organic Reaction Mechanism

3.2.1 Organic Acids

The acids that we talked about in General Chemistry usually refers to inorganic acids, such as HCl, H₂SO₄, HF etc. If the structure of the acid contains a “carbon” part, then it is an organic acid. Organic acids donate protons in the same way as inorganic acids, however the structure may be more complicated due to the nature of organic structures.

Carboxylic acid, with the general formula of R-COOH, is the most common organic acid that we are familiar with. Acetic acid (CH₃COOH), the ingredient of vinegar, is a simple example of a carboxylic acid. The K_a of acetic acid is 1.8×10^{-5} .

Another common organic acid is the organic derivative of sulfuric acid H₂SO₄.

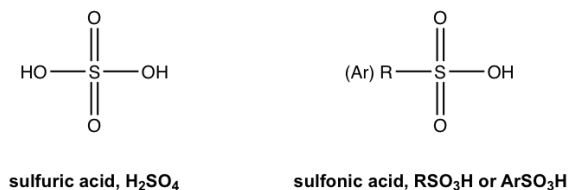

The replacement of one OH group in H₂SO₄ with a carbon-containing R (alkyl) or Ar (aromatic) group leads to the organic acid named “sulfonic acid”, with the general formula of RSO₃H, or ArSO₃H. Sulfonic acid is a strong organic acid with a K_a in the range of 10⁶. The structure of a specific sulfonic acid example called *p*-toluenesulfonic acid is shown here:

The common name is tosylic acid, and the circled part is known as the “tosyl” group, that is abbreviated as “Ts”. So the formula of tosylic acid can also be **TsOH**.

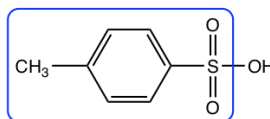

***p*-toluenesulfonic acid, TsOH
(common name: tosylic acid)**

Figure 3.1a CH₃C₆H₄SO₃H Tosylic acid

Other than the acids mentioned here, technically any organic compound could be an acid, because organic compounds always have hydrogen atoms that could potentially be donated as H⁺. Only a few examples are shown here with the hydrogen atoms highlighted in blue:

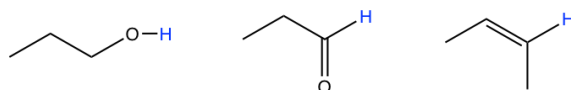

More examples of organic acids

Therefore, the scope of acids has been extended to be much broader in an organic chemistry context. We will have further discussions on the acidity of organic compounds in **section 3.3**, and we will see more acid-base reactions applied to organic compounds later in this chapter.

3.2.2 Organic Bases

While it is relatively straightforward to identify an organic acid since hydrogen atoms are always involved, sometimes it is not that easy to identify organic bases. According to the definition, a base is the species that is able to accept the proton. Organic bases may involve a variety of different structures, but they must all share the common feature of having **electron pairs** that are able to accept protons. The electron pairs could be lone pair electrons on a neutral or negative charged species, or π electron pairs. Organic bases could therefore involve the following types:

- Negatively charged organic bases: RO⁻(alkoxide), RNH⁻(amide), R⁻(alkide, the conjugate base of alkane). Since the negatively charged bases have a high electron density, they are usually stronger bases than the neutral ones.

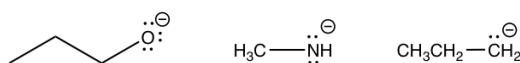

Examples of negatively charged organic bases with lone pair electrons shown in the structure

Note: Keep in mind that the lone pairs are usually *omitted* in organic structures as mentioned before. For example, with the formula of CH_3NH^- given, you should understand that the N actually has two pairs of lone pair electrons (as shown in the above structure) and it is a base.

- Neutral organic bases, for example amine, C=O group and C=C group
 - Amine: RNH_2 , R_2NH , R_3N , ArNH_2 etc (**section 2.3**). As organic derivatives of NH_3 , which is an inorganic weak base, amines are organic weak bases with lone pair electrons on N that are able to accept the proton.

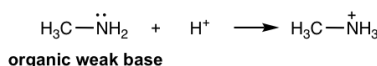
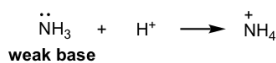

Figure 3.1b weak base and organic weak base

- Functional groups containing oxygen atoms: carbonyl group C=O, alcohol R-OH, ether R-O-R. The lone pair electrons on O in these groups are able to accept the proton, so functional groups like *aldehyde*, *ketone*, *alcohol* and *ether* are all organic bases. It may not that easy to accept this concept at the first, because these groups do not really look like bases. However, they are bases according to the definition because they are able to accept the proton with the lone pair on the oxygen atom.

Adjust your thinking here to embrace the broader scope of acids and bases in an organic chemistry context.

Here, we will take the reaction between acetone and H^+ as an example, to understand the reaction deeply by exploring the **reaction mechanism**, and learn how to use the curved arrows to show it.

A **reaction mechanism** is the step-by-step electron transfer process that converts reactants to products. *Curved arrows* are used to illustrate the reaction mechanism. Curved arrows should always start at the electrons, and end in the spot that is receiving the electrons. The curved arrows used here are similar to those for resonance structures (**section 1.4**), but are not exactly same though. Please note that in resonance structures, the curved arrows are used to show how the electrons are transferred *within* the molecule, leading to another resonance structure. For mechanism purposes, there must be arrows that connect *between* species.

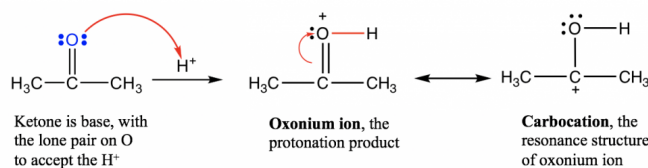

Notes for the above mechanism:

- For the acid-base reaction between C=O group and the proton, the arrow starts from the electron pair on O, and points to the H^+ that is receiving the electron pair. A new O-H bond is formed as a result of this electron pair movement.
 - In this acid-base reaction, ketone is protonated by H^+ , so this reaction can also be called the “**protonation of ketone**”.
 - The product of the protonation is called an “oxonium ion”, which is stabilized with another resonance structure, carbocation.
- Alkene (C=C): Although there are no lone pair electrons in the C=C bond of alkene, the π electrons of the C=C double bond are able to accept proton and act as base. For example:

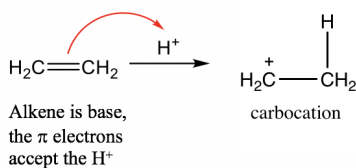

Example: Organic acid and base reaction

Predict and draw the products of following reaction and use curved arrow to show the mechanism.

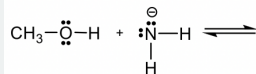

Approach: If H^+ is the acid as in previous examples, it is rather easy to predict how the reaction will proceed. However, if there is no obvious acid (or base) as in this example, how do you determine which is the acid, and which is the base?

Methanol CH_3OH is neutral, and the other reactant, NH_2^- , is a negatively charged amide. The amide with a negative charge has higher electron density than the neutral methanol, therefore amide NH_2^- should act as base, and CH_3OH is the acid that donates H^+ .

Solution:

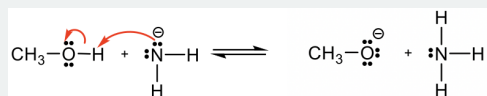

Exercises 3.1

Predict and draw the products of following reaction and use curved arrow to show the mechanism.

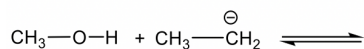

Answers to Practice Questions Chapter 3

This page titled [3.2: Organic Acids and Bases and Organic Reaction Mechanism](#) is shared under a [CC BY-NC-SA 4.0](#) license and was authored, remixed, and/or curated by [Xin Liu \(Kwantlen Polytechnic University\)](#).

3.3: pKa of Organic Acids and Application of pKa to Predict Acid-Base Reaction Outcome

As we mentioned before, all organic compounds could be acids, because they all have hydrogen atoms that could potentially be donated. Most organic acids are weak acids with a small K_a . For example, acetic acid CH_3COOH has a K_a of 1.8×10^{-5} . Lots of other organic acids are even weaker than acetic acid, and it is this weak acidity that makes it difficult to realize that some organic compounds are actually acids.

However, this weak acidity is very important in Organic Chemistry. Since it is not that very convenient to say or to remember K_a values like 1.8×10^{-5} , $\text{p}K_a$ is used more often in Organic Chemistry to refer to the relative acidity of different acids. The definition of $\text{p}K_a$ is:

$$\text{p}K_a = -\log K_a$$

The smaller the $\text{p}K_a$ value, the larger the K_a , and the stronger the acidity is.

The $\text{p}K_a$ of most organic acids range between 5~60. While it is impossible to know the $\text{p}K_a$ of every organic compound, it is very useful to understand the $\text{p}K_a$ (and acidity) based on the functional groups involved, because the same functional groups usually have similar $\text{p}K_a$ s. The approximate ranges of $\text{p}K_a$ values for seven major functional groups are listed in **Table 3.1**, which serves as a very valuable starting point for us to predict and understand the acidity of any organic molecule. The strongest organic acid listed here is carboxylic acid, with a $\text{p}K_a$ of about 5; the weakest organic acids are the alkanes with $\text{p}K_a$ values of over 50. Since approximate ranges of $\text{p}K_a$ values are listed in the table, the exact $\text{p}K_a$ value of a group varies for different compounds because of the structural differences. Fortunately however, it is usually not necessary to know the exact $\text{p}K_a$ values for most cases in organic chemistry, and the approximate range is good enough.

Acidic Hydrogen in Functional Groups	Approximate Range of pKa	Conjugate Base
Carboxylic acid $\begin{array}{c} \text{O} \\ \parallel \\ \text{R}-\text{C}-\text{OH} \end{array}$	~5	$\begin{array}{c} \text{O} \\ \parallel \\ \text{R}-\text{C}-\text{O}^{\ominus} \end{array}$
Alcohol R—OH	~16 (H ₂ O: ~16; Phenol: ~10)	R—O [⊖]
Aldehyde/Ketone $\begin{array}{cc} \text{O} & \text{O} \\ \parallel & \parallel \\ \text{R}-\text{C}-\text{H} & \text{R}-\text{C}-\text{CH}_3 \end{array}$	~16 to ~20	$\begin{array}{cc} \text{O} & \text{O} \\ \parallel & \parallel \\ \text{R}-\text{C}^{\ominus} & \text{R}-\text{C}^{\ominus}-\text{CH}_2 \end{array}$
Alkyne $\text{R}-\text{C}\equiv\text{C}-\text{H}$	~25	R—C≡C [⊖]
Amine $\text{R}-\text{NH}_2$	~35 to 40 (NH ₃ : ~38)	R—NH [⊖]
Alkene $\text{R}-\text{CH}=\text{CH}_2$	~45	R—CH=CH [⊖]
Alkane $\text{R}-\text{CH}_3$	>50	R—CH ₂ [⊖]

Table 3.1: Approximate ranges of pKa values for common organic functional groups

- Acidity is the ability of a compound to donate H⁺, so when we talk about the acidity (K_a and pK_a) of an organic compound, it must be about a specific **H atom** (highlighted blue in the table). For different H atoms in the same compound, the acidity and pK_a are different. As for the example of methanol:

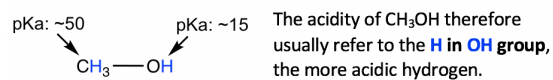

Figure 3.3a Methanol

- It is very useful to memorize the approximate ranges of pK_a listed in Table 3.1.
- The acidity of the functional groups in the table *decreases* from top to the bottom, and the basicity of the conjugate bases in the last column *increases* from top to bottom, because **the stronger the acid, the weaker the conjugate base is**.

Predict the Outcome of Organic Acid-Base Reaction — Use pK_a as Criterion

With the knowledge of acidity and pK_a, we are now ready to see how to apply this information to the understanding of organic reactions from an acid-base perspective.

The following reaction is an **example** in **Section 3.2**. If you take a closer look at the reactants and products, you will find that the “product” side also contains an acid (ammonia NH₃), and a base (methoxide CH₃O[⊖]). Now the question is, how can we be so sure that the reaction proceeds to the “product” side as written? The question can also be asked in a different way: if equilibrium is established for the reaction mixture, which side will the position of the equilibrium predominantly favour? Left or right?

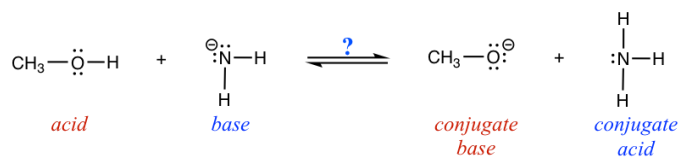

Figure 3.3b Acid-Base Reaction

To answer that question, we will learn about a general rule for acid-base reaction: **Acid-base reactions always favour the formation of the weaker acid and the weaker base.** This is because the equilibrium always favours the formation of more stable products, and weaker acids and bases are more stable than stronger ones.

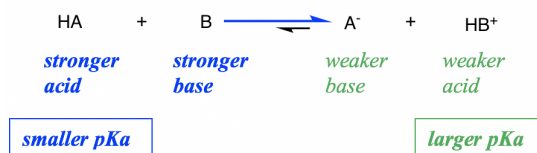

Figure 3.3c Smaller pKa and larger pKa

With pK_a values available at hand, the relative acidity of reactants vs products can be compared by comparing their pK_a values, and **the reaction will proceed to the side of the acid with a larger pK_a** (larger pK_a means smaller K_a , therefore weaker acid).

So for this reaction, the pK_a check indicates that ammonia NH_3 is a weaker acid than methanol CH_3OH , so the reaction does proceed to the right side with CH_3O^- and NH_3 as the major products.

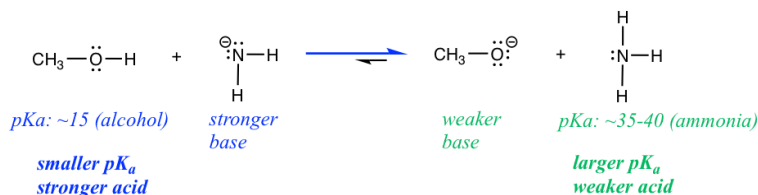

Figure 3.3d Which direction does the reaction go?

Notes: Only comparing between acids is good enough for this purpose, because if CH_3OH is stronger than NH_3 , then the conjugate base CH_3O^- must be weaker than the other base NH_2^- .

Examples

Show the products of the following reactions and predict the predominant side of the equilibrium.

Reaction 1

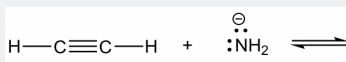

Reaction 2

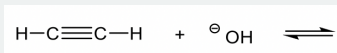

Solutions:

Reaction 1

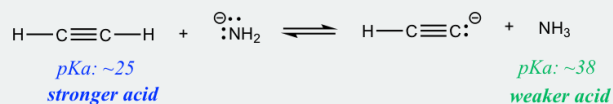

the equilibrium favors the **products (right) side** of the reaction

Reaction2

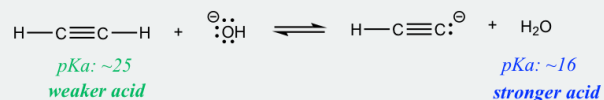

the equilibrium favors the **reactants (left) side** of the reaction

Are there any practical applications for such a prediction? Yes! Let's compare the two reactions in the exercises above. Reaction 1 indicates that if ethyne (HC≡CH) and amide (NH₂⁻) are mixed together, the reaction **does** proceed to the products side, meaning **HC≡CH could be deprotonated by amide NH₂⁻**. However, if HC≡CH and hydroxide OH⁻ are mixed together as shown in **reaction 2**, no reaction occurs, or we can say that **HC≡CH can not be deprotonated by OH⁻** because OH⁻ is not strong enough! So if you are working in the lab and have the option of choosing between NH₂⁻ or OH⁻ to deprotonate HC≡CH, you now know which one to choose.

The idea that OH⁻ is not a strong enough base may bother you a lot, since it conflicts with the “common knowledge” that we learned in General Chemistry, where OH⁻ is a strong base. Generally speaking, OH⁻ is a pretty strong base; however, it is just barely not strong enough to deprotonate HC≡CH, which is a very weak acid, with a pK_a of about ~25. Since HC≡CH is much weaker than the “weak acids” we learned in General Chemistry, a much stronger base, like NH₂⁻, is required to deprotonate it.

This page titled [3.3: pKa of Organic Acids and Application of pKa to Predict Acid-Base Reaction Outcome](#) is shared under a [CC BY-NC-SA 4.0](#) license and was authored, remixed, and/or curated by [Xin Liu \(Kwantlen Polytechnic University\)](#).

3.4: Structural Effects on Acidity and Basicity

We have learned that different functional groups have different strengths in terms of acidity. In this section, we will gain an understanding of the fundamental reasons behind this, which is *why* one group is more acidic than the other one. Many of the concepts that we will learn here will continue to apply throughout this course as we tackle many other organic topics.

3.4.1 Element Effect

A. Periodic Trend: Electronegativity

The element effect is about the **individual atom that connects with the hydrogen** (keep in mind that the acidity is about the ability to donate a certain hydrogen). Let's compare the acidity of hydrogens in ethane, methylamine and ethanol as shown below.

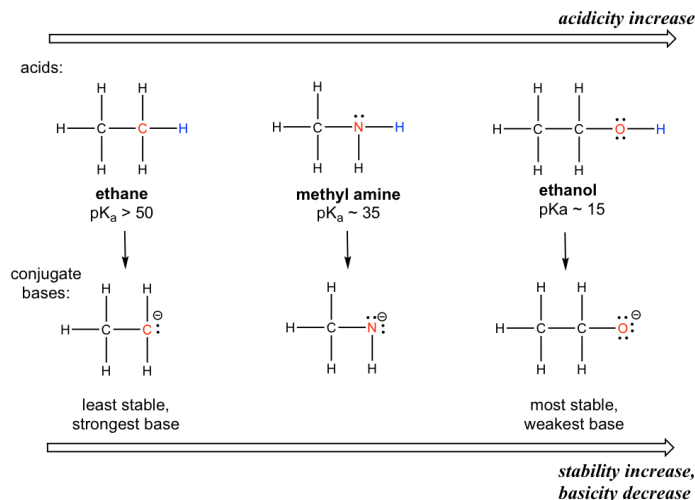

A clear trend in the acidity of these compounds is: the acidity increases for the elements from left to right along the second row of the periodic table, C to N, and then to O. This is consistent with the increasing trend of electronegativity along the period from left to right. The connection between electronegativity and acidity can be explained as the atom with a higher electronegativity being able to better accommodate the negative charge of the conjugate base, therefore stabilizing the conjugate base in a better way. Therefore, **the more stable conjugate base, the weaker the conjugate base is, and the stronger the acid is**. For the discussions in this section, the trend in the stability (or basicity) of the conjugate bases often helps to explain the trend of the acidity.

The relative acidity of elements in the same period is:

For elements in the same period, the more electronegative an atom, the stronger the acid is; the acidity increases from left to right across the period.

B. Group (vertical) Trend: Size of the atom

When moving vertically within a given group on the periodic table, the trend is that acidity increases from top to bottom. This can be illustrated with the haloacids HX and halides as shown below: the acidity of HX increases from top to bottom, and the basicity of the conjugate bases X^- decreases from top to bottom.

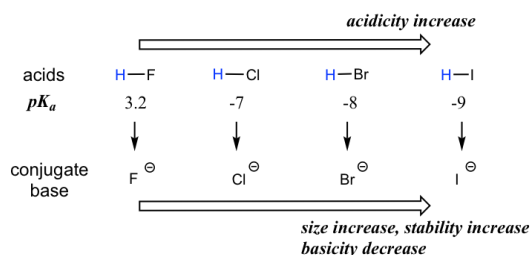

The acidity of the H in thiol SH group is also stronger than the corresponding alcohol OH group, following the same trend. For example, the pK_a of CH3CH2SH is ~ 10 , which is much more acidic than ethanol CH3CH2OH with a pK_a of ~ 16 .

In order to make sense of this trend, we will once again consider the stability of the conjugate bases. When moving vertically in the same group of the periodic table, the size of the atom overrides its electronegativity with regards to basicity. The atomic radius of iodine is approximately twice that of fluorine, so in an iodide ion, the negative charge is spread out over a significantly larger volume, so I^- is more stable and less basic, making HI more acidic.

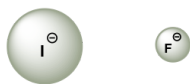

larger volume of I^- helps the negative charge to be better spread out, so I^- is more stable than F^-

Figure 3.4a Stability of fluorine and iodide ion

The relative acidity of elements in the same group is:

For elements in the same group, the larger the size of the atom, the stronger the acid is; the acidity increases from top to bottom along the group.

3.4.2. Resonance Effect

The resonance effect accounts for the acidity difference between ethanol and acetic acid. For both ethanol and acetic acid, the hydrogen is bonded with the oxygen atom, so there is no element effect that matters. However, the pK_a values (and the acidity) of ethanol and acetic acid are very different. What makes a carboxylic acid so much more acidic than an alcohol? As stated before, we begin by considering the stability of the conjugate bases, remembering that a more stable (weaker) conjugate base corresponds to a stronger acid.

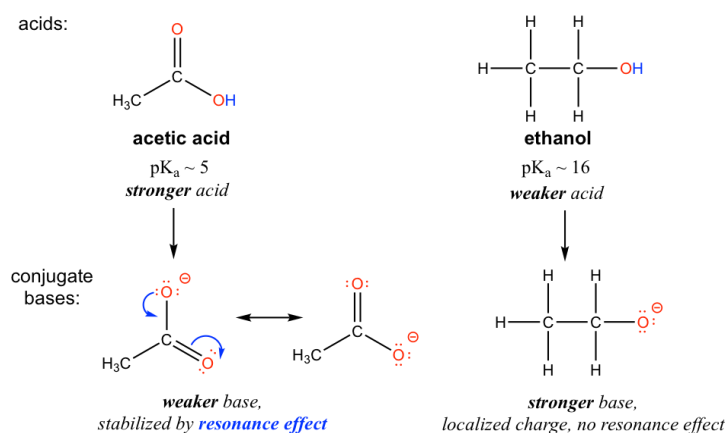

For acetate, the conjugate base of acetic acid, two resonance contributors can be drawn and therefore the negative charge can be delocalized (shared) over two oxygen atoms. However, no other resonance contributor is available in the ethoxide ion, the conjugate base of ethanol, so the negative charge is localized on the oxygen atom. As we have learned in **section 1.3**, **the species that has more resonance contributors gains stability**, therefore acetate is more stable than ethoxide, and is weaker as the base, so acetic acid is a stronger acid than ethanol.

The charge delocalization by resonance has a very powerful effect on the reactivity of organic molecules, enough to account for the big difference of over 10 pK_a units between ethanol and acetic acid. Because $pK_a = -\log K_a$, that means that there is a factor of about 10^{10} between the K_a values for the two molecules!

Examples

The pK_a of the OH group in alcohol is about 15, however OH in phenol (OH group connected on a benzene ring) has a pK_a of about 10, which is much stronger in acidity than other alcohols. Explain the difference.

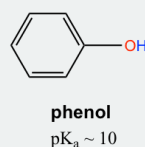
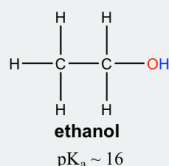

Solution:

The difference can be explained by the resonance effect. There is no resonance effect on the conjugate base of ethanol, as mentioned before. However, the conjugate base of phenol is stabilized by the resonance effect with four more resonance contributors, and the negative is delocalized on the benzene ring, so the conjugate base of phenol is much more stable and is a weaker base. Therefore phenol is much more acidic than other alcohols.

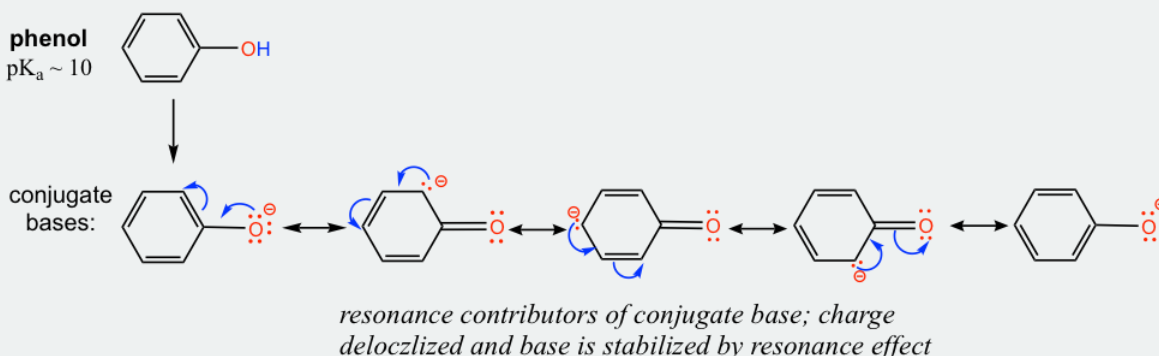

Exercises 3.2

- Practice drawing the resonance structures of the conjugate base of phenol by yourself!
- It is because of the special acidity of phenol (and other aromatic alcohols), that NaOH can be used to deprotonate phenol effectively, but not to normal alcohols, like ethanol. Show the reaction equations of these reactions and explain the difference by applying the pK_a values.

Answers to Practice Questions Chapter 3

3.4.3 Inductive Effect

Let's compare the pK_a values of acetic acid and its mono-, di-, and tri-chlorinated derivatives:

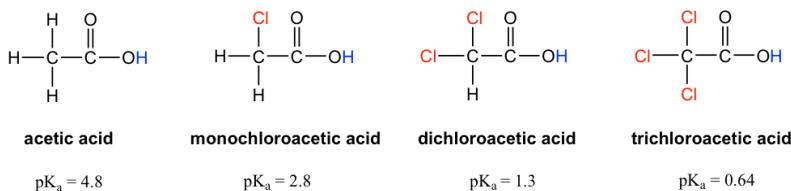
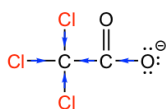

Figure 3.4b Acetic acid and its mono-, di-, and tri-chlorinated derivatives

The presence of the chlorine atoms clearly increases the acidity of the carboxylic acid group, and the argument here apparently does not have to do with the element effect. The resonance effect does not have to do with it either, because no additional resonance contributors can be drawn for the chlorinated molecules. Rather, the explanation for this phenomenon involves something called the **inductive effect**. A chlorine atom is more electronegative than hydrogen, and is thus able to 'induce', or 'pull' electron density towards itself via σ bonds in between, and therefore helps to spread out the electron density of the conjugate base, the carboxylate, and stabilize it. The chlorine substituent can be referred to as an **electron-withdrawing group** because of the inductive effect.

The inductive effect is the charge dispersal effect of electronegative atoms through σ bonds. The inductive effect is additive; more chlorine atoms have an overall stronger effect, which explains the increasing acidity from mono-, to di-, to tri-chlorinated acetic acid. The following diagram shows the inductive effect of trichloro acetate as an example.



trichloro acetate was stabilized by inductive effect: chlorine atoms pull electrons through σ bonds to help charge dispersal

Figure 3.4c Trichloro acetate was stabilized by inductive effect

Because the inductive effect depends on electronegativity, fluorine substituents have a stronger inductive effect than chlorine substituents, making trifluoroacetic acid (TFA) a very strong organic acid.

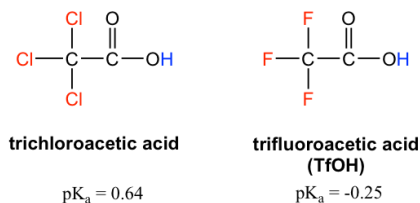
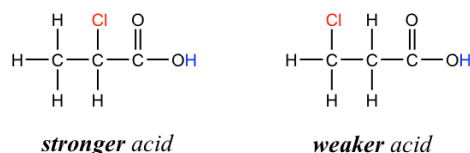

Figure 3.4d trichloroacetic acid ($pK_a = 0.64$) and trifluoroacetic acid (TfOH) ($pK_a = -0.25$)

In addition, because the inductive effect takes place through covalent bonds, its influence decreases significantly with distance — thus a chlorine that is two carbons away from a carboxylic acid group has a weaker effect compared to a chlorine just one carbon away.



3.4.4 Hybridization Effect

To introduce the hybridization effect, we will take a look at the acidity difference between alkane, alkene and alkyne.

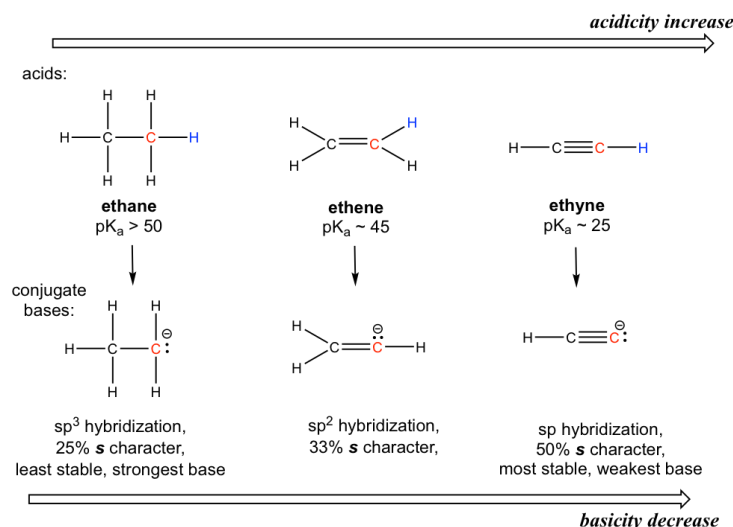

The hydrogen atom is bonded with a carbon atom in all the three functional groups, so the element effect does not invoke. Also considering about the conjugate base of each, there is no extra resonance contributor possible.

The key difference between the conjugate base anions is the hybridization of the carbon atom, that is sp^3 , sp^2 and sp respectively for alkane, alkene and alkyne. Different hybridizations leads to different **s character**, that is the percent of s orbitals out of the total amount of orbitals. The sp^3 hybridization means 25% s character (one s and three p orbitals, so s character is $1/4 = 25\%$), sp^2 hybridization has 33.3% s character, and the number is 50% for sp hybridization. Electrons of 2s orbitals are in the lower energy level than those of 2p orbitals because 2s is much closer to the nucleus. So for the anion with more s character, the electrons are closer to the nucleus and experience stronger attraction, therefore the anion has lower energy and is more stable.

The relative stability of the three anions (conjugate bases) can also be illustrated by the electrostatic potential map, in which the lighter color (less red) indicate less electron-density of the anion, and the higher stability.

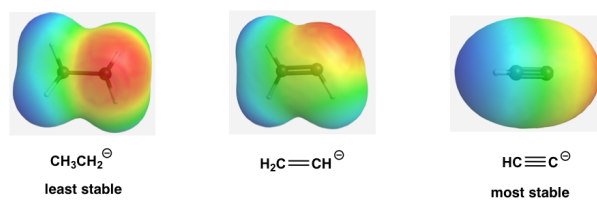

Figure 3.4e Electrostatic potential map of the conj. bases

This can also be stated in a more general way that more s character in the hybrid orbitals make the atom more electronegative. ***For the same atom, an sp hybridized atom is more electronegative than sp² hybridized atom, which is more electronegative than sp³ hybridized atom.***

This page titled [3.4: Structural Effects on Acidity and Basicity](#) is shared under a [CC BY-NC-SA 4.0](#) license and was authored, remixed, and/or curated by [Xin Liu \(Kwantlen Polytechnic University\)](#).

3.5: Lewis Acids and Lewis Bases

The Brønsted-Lowry definition works well for the reactions we learned so far, however it also limits the scope of acid-base reactions in a way where the proton H^+ must be involved. Lewis acids and Lewis bases are defined in a more inclusive way that was first introduced by G. N. Lewis in 1923.

Lewis Acid: a species that can accept an electron pair;

Lewis Base: a species that can donate an electron pair.

All Brønsted-Lowry acids and bases fit into the Lewis definition, because the proton transfer process is essentially the reaction where the base uses its electron pair to accept a proton, as indicated by the mechanism arrow that we learned earlier. Therefore in the following reaction, the BL acid, H^+ , is also the Lewis acid, and BL base, NH_3 , also fits to the definition of the Lewis base.

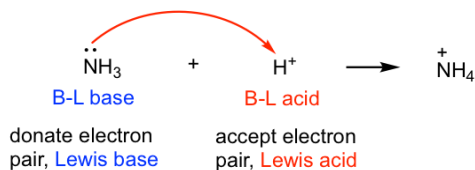

Figure 3.5a Lewis base & Lewis acid reaction

However, the Lewis definition is broader and covers more situations. For the following reaction, $\text{B}(\text{CH}_3)_3$ is the Lewis acid because boron has an incomplete octet, and the empty 2p orbital on boron is able to accept electrons. $(\text{CH}_3)_3\text{N}$ behaves as the Lewis base with the lone pair electron on N that is able to be donated.

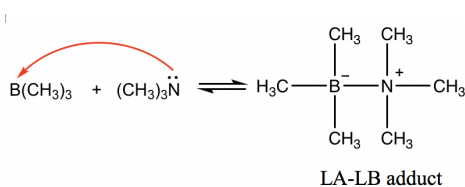

Figure 3.5b LA-LB adduct

The product between Lewis acids and Lewis bases is usually a species that has the acid and base joined together, and the product is called the “LA-LB adduct”.

Other examples of Lewis acids include electron-deficient species, such as H^+ , M^+ , M^{2+} , BH_3 , BF_3 , AlCl_3 etc. Lewis bases can be: amine, ether or other species that have lone pair electrons to donate.

Exercises 3.3

Show the product of the following LA-LB reaction:

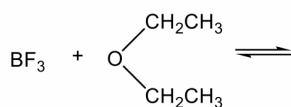

Answers to Practice Questions Chapter 3

This page titled [3.5: Lewis Acids and Lewis Bases](#) is shared under a [CC BY-NC-SA 4.0](#) license and was authored, remixed, and/or curated by [Xin Liu](#) (Kwantlen Polytechnic University).

3.6: Answers to Practice Questions Chapter 3

3.1 Predict and draw the products of following reaction; use curved arrows to show the mechanism.

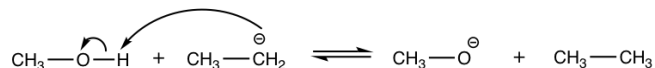

3.2

- Practice drawing the resonance structures of the conjugate base of phenol by yourself!

Solutions included in the section.

- It is because of the special acidity of phenol (and other aromatic alcohol) that NaOH can be used to deprotonate phenol effectively, but not to normal alcohols, like ethanol. Show the reaction equations of these reactions and explain the difference by applying the pK_a values.

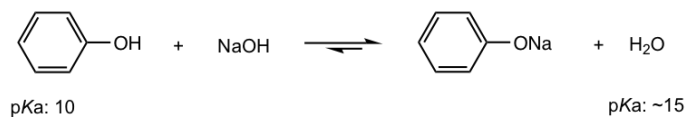

the equilibrium lies on the **product side**, so NaOH is able to deprotonate phenol

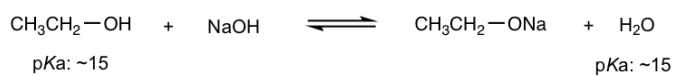

stay at equilibrium, so NaOH is **not** able to deprotonate ethanol effectively

3.3 Show the product of the following LA-LB reaction:

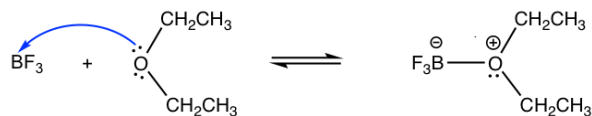

This page titled [3.6: Answers to Practice Questions Chapter 3](#) is shared under a [CC BY-NC-SA 4.0](#) license and was authored, remixed, and/or curated by [Xin Liu \(Kwantlen Polytechnic University\)](#).

CHAPTER OVERVIEW

4: Conformations of Alkanes and Cycloalkanes

- 4.1: Conformation Analysis of Alkanes
- 4.2: Cycloalkanes and Their Relative Stabilities
- 4.3: Conformation Analysis of Cyclohexane
- 4.4: Substituted Cyclohexanes
- 4.5: Answers to Practice Questions Chapter 4

Thumbnail: The ethane molecule spends 99% of its time in a specific conformation. The so-called staggered conformation is reached if, when the molecule is seen from a position on the C-C axis (as in the second half of the animation), the H atoms of the front C atom are exactly between the H atoms of the other C atom. (CC BY 2.5 Generic; ralk via [Wikipedia](#))

This page titled [4: Conformations of Alkanes and Cycloalkanes](#) is shared under a [CC BY-NC-SA 4.0](#) license and was authored, remixed, and/or curated by [Xin Liu \(Kwantlen Polytechnic University\)](#).

4.1: Conformation Analysis of Alkanes

4.1.1 Conformation

At a molecular level, a property of σ (sigma) bonds in alkane is that the bonds keep on rotating. For the example of ethane (CH_3CH_3), one methyl (CH_3) group is able to rotate around the C-C bond freely without any obstacles.

It is highly recommended that the molecular model is used here to “see” the bond rotation. With a molecular model on hand, you can hold one methyl group steady, and rotate the other methyl group.

The C-C bond is formed by the $\text{sp}^3\text{-sp}^3$ orbitals overlapping and the bond is cylindrically symmetrical, so rotation about the bond can occur easily and the molecule does not seem to change. However, a closer look indicates that the rotation of the C-C bond **does** result in a different spatial arrangement of hydrogen atoms in the molecule, as shown below:

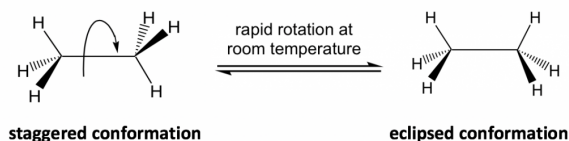

Figure 4.1a Two conformers of ethane in perspective formulas

The different spatial arrangements of the atoms/groups that result from the single bond rotation are called **conformations**. Molecules with different conformations are called **conformational isomers** or **conformers**. The two extreme conformations of ethane coming from the C-C rotation shown above are: the **staggered conformation** with all of the H atoms spread out, and the **eclipsed conformation** with all of the H atoms overlapped.

In the study of conformation, it is convenient to use certain types of structural formulas. The formula used in the drawing above is the **perspective formula** (see **section 2.1.1**) that shows the side-view of the molecule. In perspective formulas, solid and dashed wedges are used to show the spatial arrangement of atoms (or groups) around the sp^3 carbons.

Another structural formula is the **sawhorse formula** that shows the tilted top-view of the molecule.

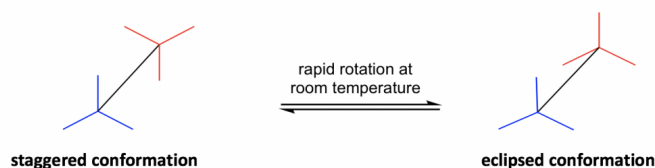

Figure 4.1b Two conformers of ethane in sawhorse formulas

The most commonly applied formula in conformation analysis is the **Newman projection** formula.

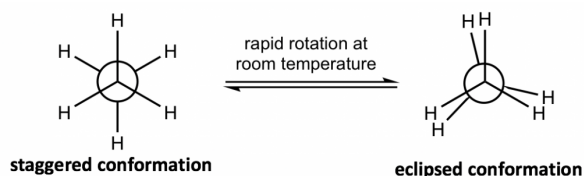

Figure 4.1c Two conformers of ethane in Newman projections

How to draw a Newman projection

To draw a **Newman projection**, we will imagine **viewing** the molecule *from one carbon to the next carbon atom directly along a selected C-C bond*, as shown below, and follow the rules:

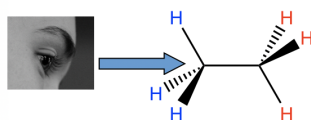

Figure 4.1d Viewing of the molecule

- The front carbon atom is shown as a point with three other bonds:



- The rear carbon atom is shown as a circle with three other bonds:



- Put the two carbons together to get the Newman projection of the staggered conformation:



- From the staggered conformation, fix the front carbon in place, and rotate the rear carbon by 60° to get the eclipsed conformation:



Note: In eclipsed conformers, the C-H bonds are supposed to be completely overlapped; however, to make the rear groups still visible, the bonds on the rear carbon are intentionally drawn slightly tilted.

4.1.2 Conformation Analysis of Ethane

Next, we will do a conformation analysis of ethane by using the Newman projections. A **conformation analysis** is an investigation of energy differences and relative stabilities of the different conformations of a compound.

The two conformations of ethane, staggered and eclipsed, are different and therefore should be in different energy levels. You may also predict intuitively that the staggered conformation is more stable and is lower energy, because the C-H bonds are arranged as far apart as possible in that conformation. That is correct! In eclipsed conformations, the H atoms on the front carbon are overlapping with the H atoms on the rear carbon, and this arrangement causes the repulsion between the electrons of C-H bonds of the two carbons. This type of repulsion is called the **torsional strain**, also known as the eclipsing strain. Due to the torsional strain, the eclipsed conformer is in the energy level that is 12 kJ/mol (or about 2.9 kcal/mol) higher than the staggered one. This can be represented graphically in a potential energy diagram as shown in Figure 4.1f.

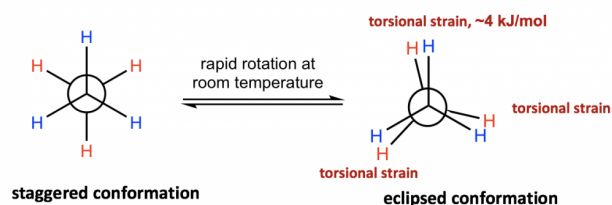

Figure 4.1e Staggered vs. eclipsed conformation

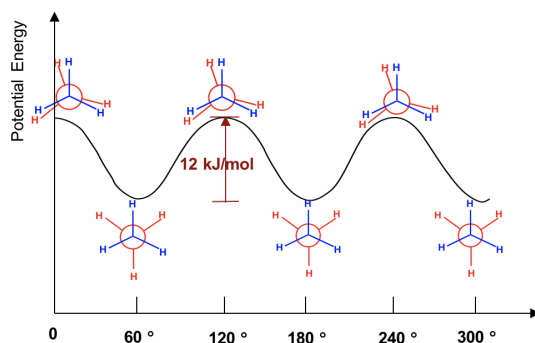

Fig. 4.1f Potential Energy of Ethane vs the Angle of Rotation about the C-C bond

Because of this energy difference, an energy barrier must be overcome when the rotation about the C-C bond occurs. However, this energy difference in ethane is rather small, and the kinetic energy of molecules at room temperature is high enough to cover it. So at room temperature, the changes from staggered to eclipsed conformers occur millions of times per second. Because of these continuous interconversions, these two conformers cannot be separated from each other. However, at any given moment, about 99% of the ethane molecules will be in a staggered conformation because of their higher stability.

4.1.3 Conformation Analysis of Propane

A similar analysis can be applied to propane as well. We will find that there are still two types of conformations, staggered and eclipsed, resulting from the rotation. The difference between propane and ethane is that there is a methyl (CH_3) group connected on the rear carbon for propane. However, that does not affect the relative stability, and the staggered conformer is more stable and in lower energy.

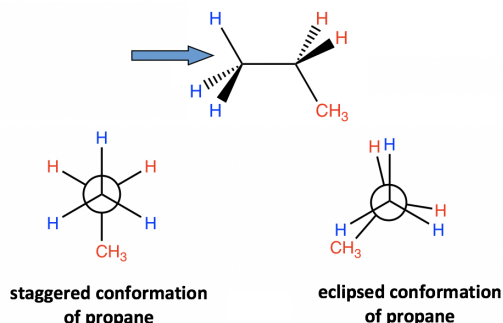

Figure 4.1g Staggered and eclipsed conformation of propane

4.1.4 Conformation Analysis of Butane

There are three C-C bonds in butane, and rotation can occur about each of them. If we pick up C1-C2 (or C3-C4) for the study, the situation is almost the same as propane, with the ethyl CH_2CH_3 group replace the CH_3 group. However, if we consider the rotation about the C2-C3 bond, the situation will be much more complex.

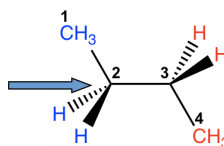

Figure 4.1h Conformation analysis of butane by viewing along C2-C3 bond

For both carbon atoms, C2 and C3, there are two hydrogen atoms and one methyl CH_3 group bonded with. We can start with the conformer in which the two CH_3 groups are **opposite** to each other, then fix the front carbon and do 60° rotations of the rear carbon to investigate **all** the possible conformations.

Exercises 4.1: Draw all the possible conformers of butane from viewing along the C2-C3 bond. Finish this practice by yourself before continue reading!

Tips for drawing all the possible conformers about a certain C-C bond:

- View along that C-C bond; circle and decide what atoms/groups are connected on each carbon;
- Start with the staggered conformation in which the largest groups on each carbon are opposite (far away) to each other (this is called the “*anti*” conformation as we will learn later);
- Keep the groups on one carbon “fixed”, and rotate the groups on the other carbon at 60° angles. Repeat the rotation five times, and you should get total of six conformers.

[Answers to Practice Questions Chapter 4](#)

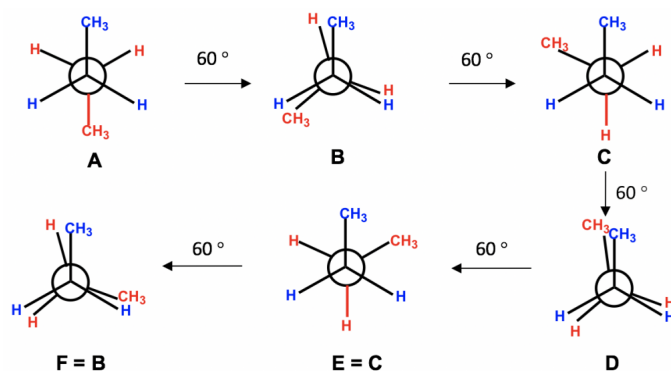

Figure 4.1i All the conformers of butane by viewing along C2-C3 bond

Among all the six conformers obtained, there are three staggered and three eclipsed. Staggered conformations **C** and **E** should be in the same energy level because the groups are arranged in equivalent way between these two conformers. Similarly, eclipsed conformations **F** and **B** are also in the same energy level. So our studies can be focused on the four conformers, **A**, **B**, **C** and **D**, that are different in terms of energy and stability.

Between the two staggered conformers **A** and **C**, **A** is more stable than **C** because the two methyl CH_3 groups in **A** are as far apart as possible. This most stable staggered conformation is called the **anti** conformation (*anti* is Greek for “opposite”). In **anti** conformations, the largest groups on the front and rear carbon are 180° opposite to each other. The other staggered conformation **C** is called a **gauche** conformation, in which the two large groups are adjacent and are 60° to each other. With the large groups being close to each other in gauche conformers, the molecule experiences **steric strain**. **Steric strain** is the strain that is caused when atoms (or groups) are close enough together that their electron clouds repel each other. Steric strain only matters when the groups are close to each other (less or equal to 60°), so steric strain does not apply in anti conformations. The magnitude of steric strain also depends on the size of group; the larger the size, the higher the steric strain. As a result, there is no steric strain between two small hydrogen atoms, even if they are close to each other.

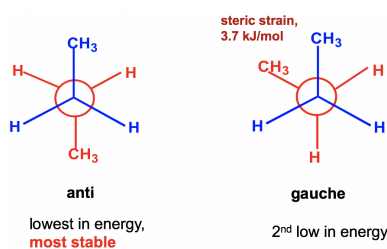

Figure 4.1j Anti and gauche conformations

Between the two eclipsed conformers **B** and **D**, **D** is less stable than **B**, because the two CH_3 groups are eclipsing (overlapping) each other in **D**, causing both torsional and steric strains.

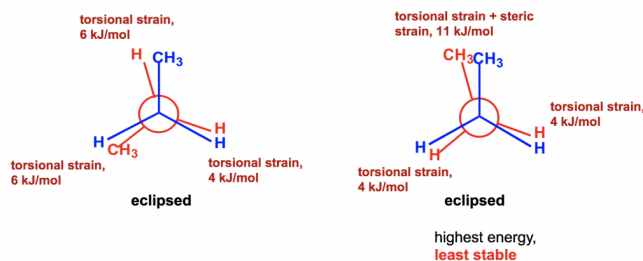

Figure 4.1k Comparison between the two eclipsed conformations

The energy difference of all the conformers obtained from the rotation about the C2-C3 bond are shown in the potential energy diagram **Fig. 4.11**. The curve is more complex than that of ethane since there are four different energy levels corresponding to four conformers with different stabilities. Even the energy barriers for the rotations are larger than that of ethane, but they are still not high enough to stop rotation at room temperature.

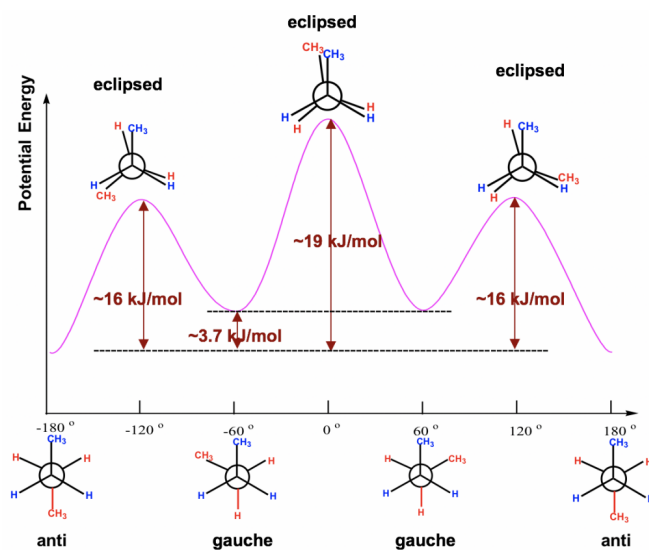

Figure 4.11 Potential Energy of Butane vs the Angle of Rotation about the C2-C3 bond

Exercises 4.2

Draw all conformers for 3-methylpentane by viewing along the C2-C3 bond, and order them from the most stable to least stable.

[Answers to Practice Questions Chapter 4](#)

This page titled [4.1: Conformation Analysis of Alkanes](#) is shared under a [CC BY-NC-SA 4.0](#) license and was authored, remixed, and/or curated by [Xin Liu \(Kwantlen Polytechnic University\)](#).

4.2: Cycloalkanes and Their Relative Stabilities

While the open chain alkanes have conformational isomers because of bond rotation, will this apply to cycloalkanes as well? In this section, we will take a look at properties of cycloalkanes first, and then investigate how the different conformers of cycloalkanes contribute to the different stabilities.

The short line structural formulas of cycloalkanes simply look like shapes such as a triangle, square etc. The internal angles of the shapes can be calculated with geometry, as shown below.



Figure 4.2a Short line structural formula of cycloalkanes

An interesting fact about the cycloalkanes is that they have different relative stabilities, and the stability depends on the size of the ring. It has been observed that cyclic compounds found in nature usually are in 5- or 6-membered rings, and the 3- or 4-membered rings are rather rare.

To explain this stability difference, German chemist Adolf von Baeyer proposed the “Bayer Strain Theory”. By assuming all the rings are in a *flat* (or planar) shape, Bayer Theory suggests that the difference between the ideal bond angle (which is 109.5° for sp^3 carbon) and the angle in the planer cycloalkane causes the strain, which is called **angle strain**. According to the Bayer Theory, cyclopentane would be the most stable because its bond angles, 108° , are closest to the ideal angle of 109.5° . Cyclopropane would be the least stable one since it has the largest angle deviation of 49.5° (60° vs 109.5°). It was also predicted that cyclohexane would be less stable than cyclopentane because of the larger angle deviation (10.5° deviation for cyclohexane vs 1.5° for cyclopentane), and as the number of sides in the cycloalkanes increases beyond six the stability would decrease.

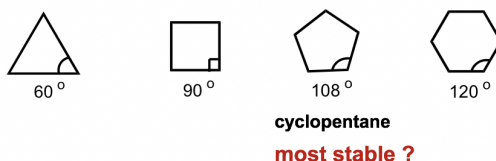

Figure 4.2b Which cyclo is stable?

However, experimental results show a different trend. It turns out that **cyclohexane** is the most stable ring that is strain-free, and is as stable as a chain alkane. Furthermore, cyclic compounds do not become less and less stable as the number of rings increases.

To measure the relative stability of cycloalkanes, the heat of combustion (ΔH_{comb}) for each cycloalkane was measured. The heat of combustion is the amount of heat released when the compounds burns completely with oxygen. The cycloalkanes will be in higher energy levels than corresponding chain alkanes because of strain energy. Therefore, when cycloalkane burns, more heat will be released, so the difference of ΔH_{comb} between cycloalkane vs the “strainless” chain alkane is just the amount of strain energy, as shown below. The larger the difference, the higher the strain energy of the cycloalkane. The strain energy for different cycloalkanes measured by this method are listed in **Table 4.1**.

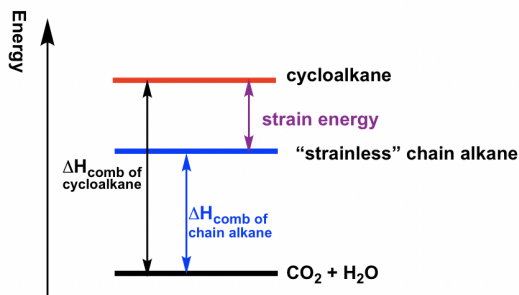

Figure 4.2c The relationship between heat of combustion and strain energy

cyclopropane	cyclobutane	cyclopentane	cyclohexane
--------------	-------------	--------------	-------------

Strain Energy (KJ/mol)	114	110	25	0
------------------------	-----	-----	----	---

Table 4.1 Strain Energies of Cycloalkanes

The major drawback of the Baeyer Theory was that we must assume that all the rings are flat. The highest stability of cyclohexane from experimental results indicate that the rings may not be in a planar shape. We will have a closer look at the actual shape and conformation of 3-, 4-, 5- and 6-membered cycloalkanes.

Cyclopropane

With three carbons for the ring, cyclopropane must be planar.

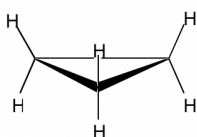
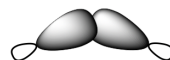

Figure 4.2d Cyclopropane

The bond angle in cyclopropane is 60° , derived significantly from the optimal angle of 109.5° , so it has very high angle strains. The sp^3-sp^3 orbitals can only overlap partially because of the angle deviation, so the overlapping is not as effective as it should be, and as a result the C-C bond in cyclopropane is relatively weak.



effective overlap,
normal strong bond



poor overlap,
weak bond in cyclopropane

Because of the poor overlapping of sp^3-sp^3 orbitals, the bonds formed in cyclopropane resemble the shape of a banana, and are sometimes called banana bonds.

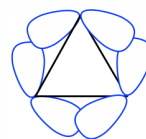
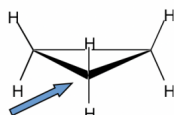
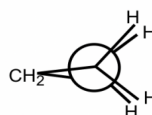

Figure 4.2e "Banana bonds" of cyclopropane

Other than the angle strains, all the adjacent C-H bonds are eclipsed in cyclopropane, therefore the torsional strains are applied as well. Such a strain can be "viewed" more clearly from the Newman projection of cyclopropane.



viewing along the C-C bond with blue
arrow to draw the Newman projection



Newman projection of cyclopropane

The Newman projection of cyclopropane might seem weird at first glance. For cyclopropane, there are three carbons, so the **CH₂ group connects with both front and rear carbons** of the Newman projection.

Because of the high level of angle strains and torsional strains, 3-membered rings are unstable. They rarely exist in nature and undergo ring-opening reaction easily to release the strains.

Cyclobutane

Cyclobutane is not planar. The ring puckers (or folds) slightly due to the efforts of releasing some torsional strain. Meanwhile, cyclobutane still has a considerable amount of angle strains as the internal angles become about 88° with the folded shape. Overall, cyclobutane is an unstable structure with rather high level of strains.

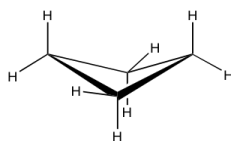

Cyclopentane

Cyclopentane is not planar as well and the total level of strain is lowered quite a lot. It also puckers and adopts a bent conformation where one carbon atom sticks out of the plane of the others, which helps to release the torsional strain by allowing some hydrogen atoms to become almost staggered.

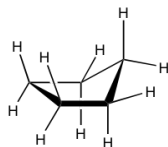

This bent shape of cyclopentane is also called the “envelope” conformation. The envelope conformation can undergo a process called “ring flipping” as a result of C-C bond rotation. More discussions about ring flipping will be included in the section of cyclohexane.

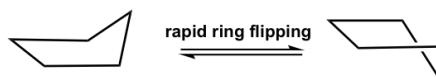

This page titled [4.2: Cycloalkanes and Their Relative Stabilities](#) is shared under a [CC BY-NC-SA 4.0](#) license and was authored, remixed, and/or curated by [Xin Liu \(Kwantlen Polytechnic University\)](#).

4.3: Conformation Analysis of Cyclohexane

Chair conformation of cyclohexane

Cyclohexane is the **most stable** cycloalkane. It is strain-free, meaning neither angle strains nor torsional strains apply, and it shows the same stability as chain alkanes. This special stability is due to a unique conformation that it adopts. The most stable conformation of cyclohexane is called “**chair**” **conformation**, since it somewhat resembles a chair.

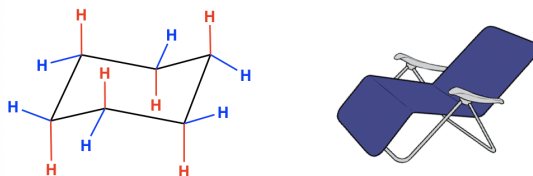

Chair conformation of cyclohexane

In the chair conformation of cyclohexane, all the carbons are at 109.5° bond angles, so no angle strain applies. The hydrogens on adjacent carbons are also arranged in a perfect staggered conformation that makes the ring free of torsional strain as well. This will be illustrated more clearly later when we learn about the Newman projection of the chair conformation.

Properties of the chair conformation

In the chair conformation of cyclohexane, the total twelve C-H bonds can be divided into two categories based on the orientations, which are **axial (“a”)** and **equatorial (“e”)**. In the structure below, the six red coloured bonds are *axial* and the six blue coloured bonds are *equatorial*. Axial bonds are vertical and perpendicular to the average plane of the ring, while the equatorial bonds are more “flat” and extend from the perimeter of the ring. For both “a” and “e”, they can either point up \uparrow (above the ring), or point down \downarrow (below the ring). The trending of “a” and “e” bonds in the chair conformation can be summarized as:

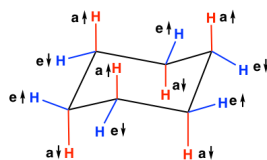

- Each carbon has one “a” bond and one “e” bond; if one bond points up \uparrow (above the ring), the other has to point down \downarrow (below the ring);
- For the same type of bonds, the orientation up \uparrow and down \downarrow alternates from one carbons to the adjacent carbon, meaning if a certain carbon has a \uparrow , then the adjacent carbon must have a \downarrow ;
- For the total twelve C-H bonds: $3a\uparrow$, $3a\downarrow$, $3e\uparrow$, $3e\downarrow$.

How to draw chair conformation

It is important to be able to understand and recognize all the bonds in the chair conformation, and you are also expected to be able to draw the conformation correctly and quickly. The procedure is:

1. Draw two parallel lines of the same length both point slightly down (if connected, they would form a parallelogram with an

internal angle of about $60^\circ/120^\circ$).

2. Connect the right ending points of the two lines with a “V” shape, so that the vertex of the V points to the upper right

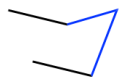

3. Connect the left starting points of the two lines with another “V” shape, so that the vertex of the V points to the bottom left

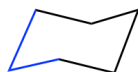

Add up all of the “a” bonds on each carbon as the **vertical** lines, follow the alternating trend on adjacent carbons

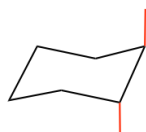

4. Add all of the “e” bonds by following the trend in which on a certain carbon, if an “a” bond points up, then an “e” bond must point down, and vice versa. Also notice that the “e” bond is parallel to the C-C bond which is one bond away, as shown below. The “**green e**” is parallel to the “**green C-C bond**”, and the “**blue e**” is parallel to the “**blue C-C bond**”. (It is more challenging to draw “e” bonds, and following the above trend makes it easier).

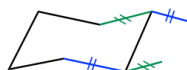

It is highly recommended that a [molecular model set](#) is used as a study tool in this section. Assemble a cyclohexane ring with the model, and get familiar with all the bonds in chair conformation.

Practice makes perfect! A lot of practice is required to become skilled in drawing and understanding the chair conformation.

Ring flipping

When a cyclohexane ring undergoes a chair-chair conformation conversion, that is known as **ring flipping**. Ring flipping comes from C-C bond rotation, but since all of the bonds are limited within the ring, the rotation can only occur *partially*, which leads to the ring “flipping”. Cyclohexane rapidly interconverts between two stable chair conformations because of the ease of bond rotation. The energy barrier is about 45 kJ/mol, and the thermal energies of the molecules at room temperature are great enough to cause about 1 million interconversions to occur per second.

For cyclohexane, the ring after flipping still appears somewhat identical to the original ring, however there are some changes happening on the C-H bonds. Specifically, all the “**a**” bonds become “**e**” bonds and all the “**e**” bonds become “**a**” bonds, however their relative positions in terms of the ring, up or down, remain the same. The ring flipping is shown in the equation below. Compare the carbon with the same numbering in the two structures to see what happened to the bonds due to ring flipping.

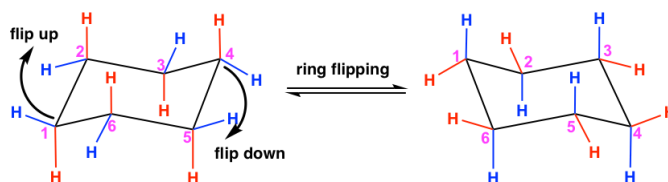

Taking C #1 as an example, you will notice that the red **a**↓ converted to a red **e**↓, and the blue **e**↑ converted to a blue **a**↑ after ring flipping.

Summary of ring flipping for chair conformation:

- This is **NOT** rotation, but ring flipping
- The two structures are conformation isomers (or conformers)
- all “a” bonds become “e” bonds and all “e” bonds become “a” bonds
- These two conformations are **equivalent** for the cyclohexane ring itself (without any substituents), with the same energy level

A molecular model is very useful in understanding ring flipping.

Newman projection of chair conformation

The chair conformation is strain free, with all the C-H bonds in staggered position. However, it is not that easy to see the staggered conformation in the drawings we have so far, and Newman projection help for this purpose.

To draw Newman projections for the chair conformation of cyclohexane, we also need to pick up the C-C bond to view along, just as we did for alkanes. Since there are a total of six C-C bonds, we will pick two of them, and these two need to be parallel to each other.

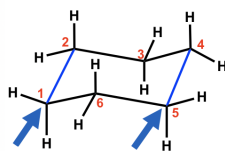

For the chair conformation example here, the two blue parallel C-C bonds are picked up for viewing, which are C1-C2 and C5-C4. (There are 3 pairs of parallel bonds in the chair conformation, any pair can be picked with the resulting Newman projection looking the same).

For the C1-C2 bond, C1 is the ‘front’ carbon and C2 is the ‘rear’ carbon; for the C5-C4 bond, C5 is the ‘front’ carbon and C4 is the ‘rear’ carbon. These two bonds will be represented by two ‘Newman projections’ that we are familiar with (two circle things) and each represents two carbons, as shown below:

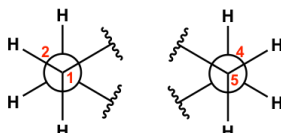

Keep in mind that there are a total of six carbons in the ring, and the the drawing above only shows four of them with C3 and C6 being left out. Additionally, the two ‘separated’ Newman projections above are actually connected to both C3 and C6, so the overall Newman projection of the chair conformation of cyclohexane looks like this:

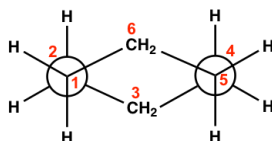

The *staggered* conformation of hydrogens are shown clearly in the Newman projection here!

Notes for Newman projections of the chair conformation (refer to the drawing below):

- The ‘a’ or ‘e’ bonds on four carbons (C1, C2, C4 and C5) are shown explicitly, while the bonds on C3 and C6 are just shown as CH₂.
- The vertical red C-H bonds are the ‘a’ bonds, the ‘flat’ blue C-H bonds are the ‘e’ bonds.
- The dashed line in the drawing below can be regarded as the average plane of the ring. Those above the line are the bonds point up ↑, those below the line are the bonds point down ↓.
-

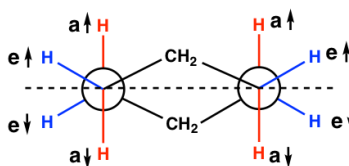

Other conformation of cyclohexane

The chair conformation is the most stable one with the lowest energy, but it is not the only conformation for cyclohexane. During the ring flipping from one chair conformation to another chair conformation, the ring goes through several other conformations, and we will only talk briefly about the boat conformation here.

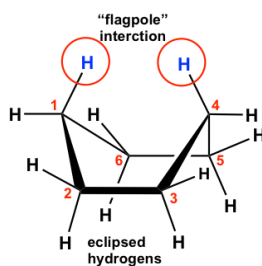

Figure 4.3a Boat conformation of cyclohexane

The boat conformation comes from partial C-C bond rotations (only flipping one carbon up to convert the chair to a boat) of the chair conformation, and all the carbons still have 109.5° bond angles, so there are no angle strains. However, the hydrogens on the base of the boat are all in eclipsed positions, so there are torsional strains. This can be illustrated by the Newman projection below. The Newman projection is drawn by viewing along C6-C5 and C2-C3 bonds of the above boat conformation.

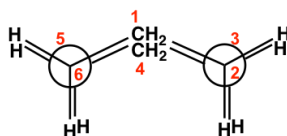

Figure 4.3b Newman projection of boat conformation

Other than that, the two hydrogen atoms on C1 and C4 are very close to each other and causes steric strain. This is also called the “flagpole” interaction of the boat conformation. The two types of strains make the boat conformation have considerably higher energy (about 30 kJ/mol) than the chair conformation.

This page titled [4.3: Conformation Analysis of Cyclohexane](#) is shared under a [CC BY-NC-SA 4.0](#) license and was authored, remixed, and/or curated by [Xin Liu \(Kwantlen Polytechnic University\)](#).

4.4: Substituted Cyclohexanes

Monosubstituted cyclohexane

For the cyclohexane ring itself, the two conformers from the ring flipping are equivalent in terms of energy since there are always six hydrogens in *axial* position and six hydrogens in *equatorial* position. For substituted cyclohexane however, the two chair conformations are **not** equivalent any more. Let's see the example of methylcyclohexane.

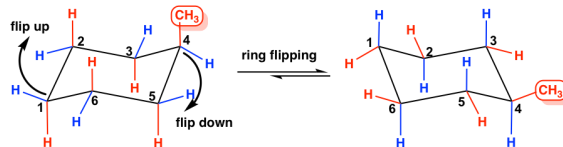

Figure 4.4a (Left one) I, less stable & (Right one) II, more stable

Methylcyclohexane has two chair conformations that are interconvertible through the ring flipping. In conformation **I** the methyl group occupies an *axial* position, and in conformation **II** the methyl group occupies an *equatorial* position. Studies indicate that the **conformer II** with the *equatorial*-methyl is more stable, with the energy of about 7.6 kJ/mol lower than the other conformer.

This difference is due to the “**1,3-diaxial interaction**”. In *axial*-methyl conformation, the methyl CH₃ group (regarded as #1 position) is very close to the *axial* hydrogens that is one carbon away (regarded as #3 position), and it causes the repulsion between each other that is called the 1,3-diaxial interaction. This type of repulsion is essentially the same as the *gauche* steric strain because the CH₃ group and the CH are in *gauche* position. While for *equatorial*-methyl conformer, no such strains applied because the CH₃ group and the CH are in *anti*-position. This interaction could be illustrated more clearly by Newman projection.

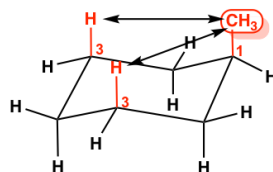
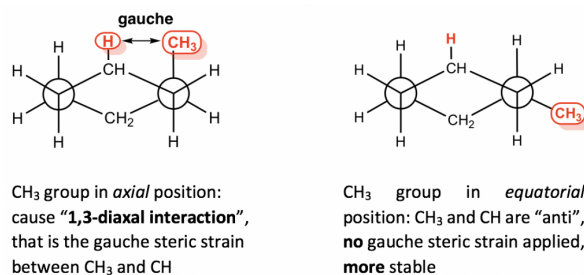

Figure 4.4b 1,3-diaxial interaction



For mono-substituted cyclohexane, the *equatorial*-conformer is more stable than the *axial*-conformer because of the 1,3-diaxial interaction.

Since 1,3-diaxial interaction is essentially the steric strain, so the larger the size of the substituent, the greater the interaction is. For *t*-butylcyclohexane, the conformation with the *t*-butyl group in the *equatorial* position is about 21 kJ/mol more stable than the *axial* conformation.

Because of the stability difference between the two chair conformers, the *equatorial*-conformation is always the predominant one in the equilibrium mixture. The larger the size of the substituent, the larger the energy difference and the equilibrium constant *K*, so the equilibrium lies more toward the “*equatorial*” side. For methylcyclohexane, there is about 95% of *equatorial*-conformer in the mixture, and the percentage is about 99.9% for *t*-butylcyclohexane.

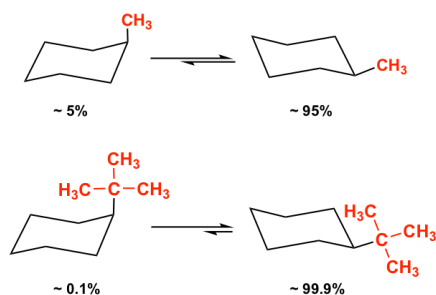

Disubstituted cyclohexane

When there are two substituents on different carbons of a cycloalkane, there are two possible relative positions between the two groups, they can be either on the same side, or opposite side, of the ring, that are called **geometric isomers**, a type of **stereoisomers** (more discussions in **Chapter 5**). The isomer with two groups on the same side of the ring is the “*cis*” isomer, and the one with two groups on opposite side is called the “*trans*” isomer. Because the C-C bond can not rotate freely due to the restriction of the ring, the two geometric isomers can not be interconverted.

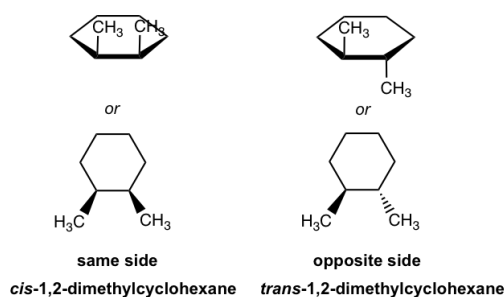
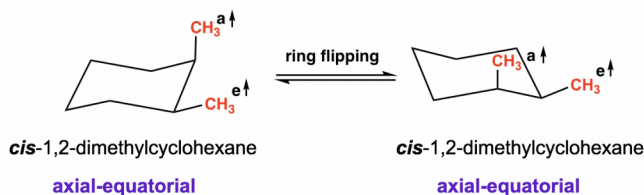

Figure 4.4c *cis*-1,2-dimethylcyclohexane (same side) & *trans*-1,2-dimethylcyclohexane (opposite side)

So now when considering about the conformational isomer, the stereoisomers should be taken into account as well. The general guideline for determining the relative stability of conformers for a certain isomer is:

- The steric effects of all substituents are *cumulative*, more substituents in *equatorial* positions, when possible, the more stable the conformation isomer will be.
- For different substituents, the conformer with *larger* substituent in *equatorial* position is more stable.

Let us start with *cis*-1,2-dimethylcyclohexane, and compare between the two possible chair conformations:



For both conformations, there is one methyl group in *equatorial* and the other methyl group in *axial*, so the two conformers are **equivalent**, have same energy and stability level.

How to tell a isomer in chair conformation is *cis* or *trans*? A general way to recognize is to check that whether a group attached by the bond is above the ring (↑, point up), or below the ring (↓, point down). If both groups point to the same side, the compound is *cis* isomer; otherwise it is *trans* isomer.

How about the *trans*-1,2-dimethylcyclohexane? There are also two possible chair conformations:

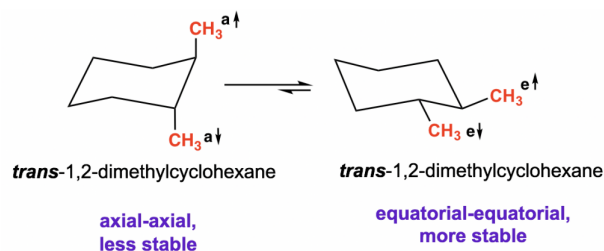

In one conformation both methyl groups are *axial*, in the other conformation both methyl groups are *equatorial*. These two conformers are **not** equivalent, and the di-*equatorial* one is the more stable conformation as we would expect.

cis-1-fluoro-4-isopropylcyclohexane is the structure with two different substituents. Both chair conformations have one *axial* substituent, and one *equatorial* substituent. According to the guideline, the conformer with *larger* substituent in *equatorial* is more stable because if the large group is axial, stronger steric strain will be generated and it is less stable.

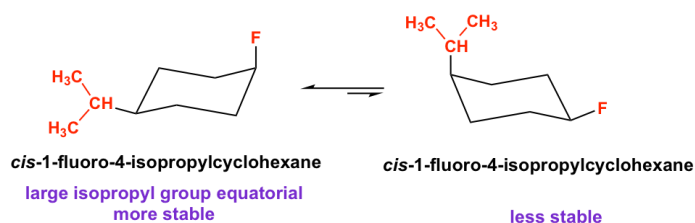

Exercises 4.3

Determine which is the more stable isomer, *cis* -1-ethyl-2-methylcyclohexane or *trans* -1-ethyl-2-methylcyclohexane?

Tips: draw all the chair conformers of each isomer, and decide which is the most stable one.

[Answers to Practice Questions Chapter 4](#)

This page titled [4.4: Substituted Cyclohexanes](#) is shared under a [CC BY-NC-SA 4.0](#) license and was authored, remixed, and/or curated by [Xin Liu](#) ([Kwantlen Polytechnic University](#)).

4.5: Answers to Practice Questions Chapter 4

4.1 Solutions included in the section.

4.2 Draw all conformers for 3-methylpentane by viewing along C2-C3 bond, and order them from the most stable to least stable.

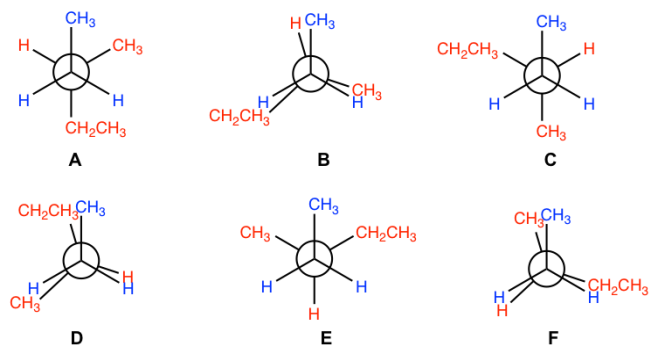

stability: A > C > E > B > F > D

most stable

least stable

4.3 Determine which is the more stable isomer, *cis*-1-ethyl-2-methylcyclohexane or *trans*-1-ethyl-2-methylcyclohexane?

The *trans*-isomer has the most stable conformer with both substituents are at equatorial positions, therefore *trans*-isomer is the more stable one.

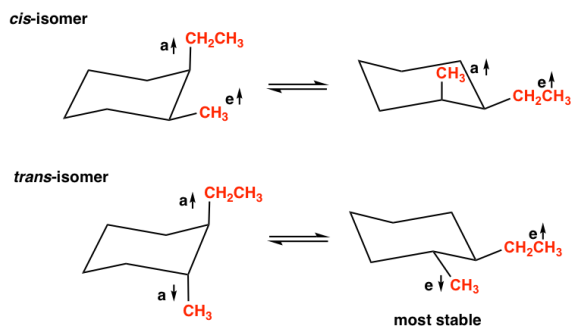

This page titled [4.5: Answers to Practice Questions Chapter 4](#) is shared under a [CC BY-NC-SA 4.0](#) license and was authored, remixed, and/or curated by [Xin Liu \(Kwantlen Polytechnic University\)](#).

CHAPTER OVERVIEW

5: Stereochemistry

- 5.1: Summary of Isomers
- 5.2: Geometric Isomers and E/Z Naming System
- 5.3: Chirality and R/S Naming System
- 5.4: Optical Activity
- 5.5: Fisher Projection
- 5.6: Compounds with More Than One Chirality Centers
- 5.7: Answers to Practice Questions Chapter 5

Thumbnail: Two enantiomers of a generic amino acid that are chiral. (Public Domain; unknown author via [Wikipedia](#))

This page titled [5: Stereochemistry](#) is shared under a [CC BY-NC-SA 4.0](#) license and was authored, remixed, and/or curated by [Xin Liu](#) ([Kwantlen Polytechnic University](#)).

5.1: Summary of Isomers

In stereochemistry topic, we will learn more different types of isomers. To clarify the concepts, it is a good idea to have a summary about the isomers in organic chemistry. There are two major types of isomers, **constitutional isomers** and **stereoisomers**. We have had detailed discussions on constitutional isomers in **Chapter 2**, and will focus on stereoisomers in this chapter. Stereoisomers are molecules with same bonding, but groups are in different spatial arrangement. At beginning of this chapter, we will learn more about geometric isomers in alkenes and the E/Z naming system. Then we will move on to a brand new category of stereoisomers, the isomers with chirality center. The flowchart here (**Fig. 5.1a**) show the correlation and difference between different types of isomers (pay attention to the definitions included) and provides useful guideline for the learning.

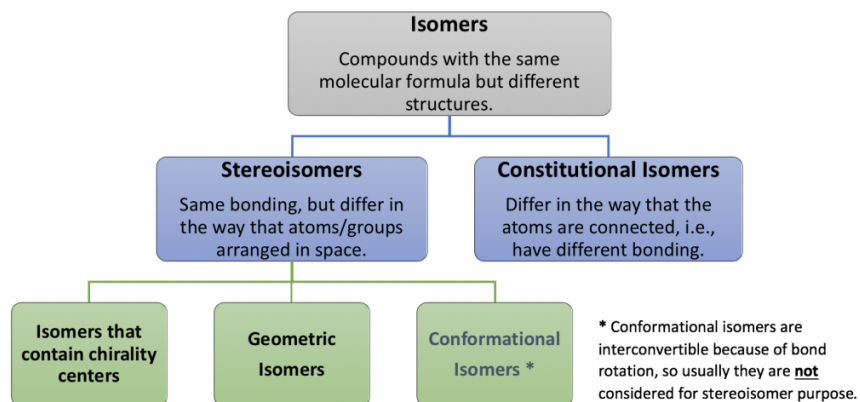

Fig. 5.1a Summarization of Isomers

This page titled [5.1: Summary of Isomers](#) is shared under a [CC BY-NC-SA 4.0](#) license and was authored, remixed, and/or curated by [Xin Liu](#) (Kwantlen Polytechnic University).

5.2: Geometric Isomers and E/Z Naming System

Geometric Isomers of Alkenes

In the discussions about 1,2-dimethylcyclohexane in **Chapter 4**, we have learned that there are two **geometric isomers** possible for that compound, that are *cis* and *trans*. The restricted C-C bond rotation of cyclic structure result in the *cis* or *trans* isomer of 1,2-dimethylcyclohexane. Restricted rotation also can be caused by a double bond, so geometric isomers apply to some alkenes as well.

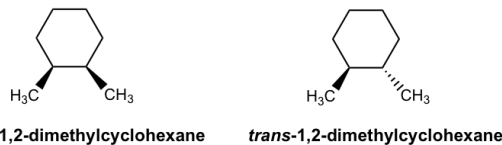

Figure 5.2a Geometric isomers of disubstituted cycloalkanes

For the example of 2-butene, the condensed structural formula $\text{CH}_3\text{-CH=CH-CH}_3$ does not really represent the trigonal planar shape of the sp^2 carbons with double bonds. To show the shape explicitly, we need to draw the Kekulé structure that show all the bond angles. Then it will be noticed that there are two different shapes of 2-butene, with the CH_3 groups on either the same side or opposite side of the double bond.

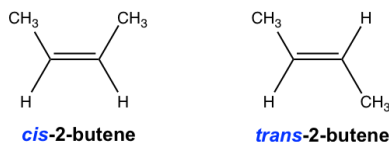
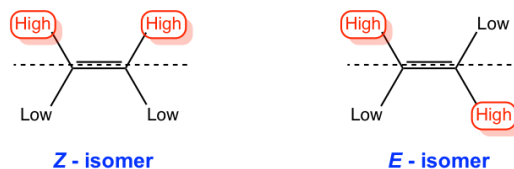

Figure 5.2b Geometric isomers of some alkenes

They are geometric isomers and can be labelled as *cis* or *trans* in a similar way as disubstituted cycloalkane. *Cis/trans* is the common designation for geometric isomers and might be ambiguous for some structures, here we will learn the IUPAC naming system for geometric isomers of alkene, that is the *E/Z* naming system.

E/Z Naming System

To do the *E/Z* designation, at first, the groups connected on each sp^2 double bond carbon will be assigned the priority based on the atomic number (see following guidelines for details), then the isomer with same priority group on the same side of double bond is assigned as “*Z*”, and the isomer with the same priority group on the opposite side of double bond is called “*E*”. Both *E* and *Z* come from German, “*Zusammen*” means same side and “*Entgegen*” means opposite.



The guidelines for assigning group priority in E/Z naming system

1. Priority is assigned based on the **atomic number** of the atoms bonded *directly* to the sp^2 double bond carbon, the larger the atomic number, the higher the priority (isotopes with higher mass number has higher priority). For example: $\text{S} > \text{O} > \text{N} > \text{C} > \text{H}$.

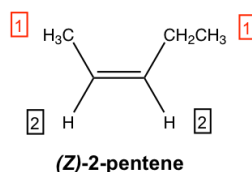

For the above structure of 2-pentene: on the left side sp^2 carbon, methyl group CH_3 is higher than hydrogen atom because $\text{C} > \text{H}$; on the right side sp^2 carbon, ethyl group CH_2CH_3 , is also higher than hydrogen. With higher priority group on both side of the double bond, this is the *Z* isomer, the complete name of the compound is **(Z)-2-pentene**.

The group with higher priority is labelled as #1, and the group with lower priority is labelled as #2 in this book.

2. If the two groups bonded directly on an sp^2 carbon start with the same atom, means there is a tie from step 1, then we move on to the atoms that connected to the “tied” atom, priority increases as the atomic number of the next attached atom increases.

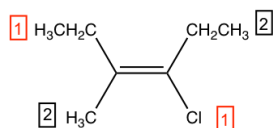

(*E*)-3-chloro-4-methyl-3-hexene

For the above structure, it is obvious that Cl is higher than C (C of CH_2CH_3 group) on the right side sp^2 carbon.

On the left side sp^2 carbon, we need to compare between methyl CH_3 group and ethyl CH_2CH_3 group. Both groups has carbon atom attached directly on the sp^2 carbon, that is a tie. In CH_3 group, the carbon atom is bonded to **H, H, H**; while in CH_2CH_3 group, the carbon atom is bonded with **H, H, C**. So ethyl CH_2CH_3 is higher than methyl CH_3 (see **Note** below). With higher priority group on opposite side of the double bond, this is the *E* isomer, the complete name of the compound is: (***E***)-3-chloro-4-methyl-3-hexene.

Note #1: For this round of comparison between **H, H, H** and **H, H, C**, compare the single atom with the greatest number in one group *verse* the single atom with the greatest number in the other group. So **H** in one group *verse* **C** in the other group, since $C > H$, therefore CH_2CH_3 is higher than CH_3 . Remember do **not** add the atomic numbers. For example, if one group has **C, C, C**, and the other group has **C, O, H**, then the C, O, H side is higher because O is higher than C.

Note #2: The above compound is *cis*-isomer if using the *cis/trans* naming system (both ethyl group are on the same side of double bond), but is *E*-isomer for *E/Z* system. So the *cis/trans* and *E/Z* are two different naming systems, don't always match.

3. Repeat step 2 if necessary, until the priority is assigned.

Examples: What is the correct structural formula of (*)-2-bromo-3-chloro-2-butene?*

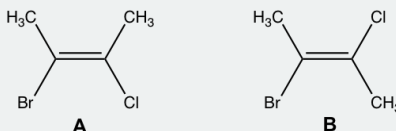

The answer is B.

Examples: Draw the structure of (*)-3-methyl-2-pentene*

Answer

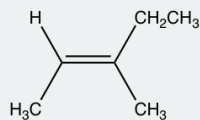

Examples: Order the following groups based on priority.

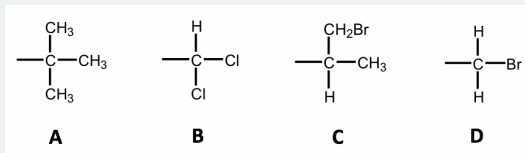

Approach:

1st round: C, C, C, C (tie);

2nd round:

A: C bonded to **C, C, C**; (3rd)

B: C bonded to **H, Cl, Cl**; (Cl is the 2nd high)

C: C bonded to **H, C, C**; (4th)

D: C bonded to **H, H, Br** (Br is the highest)

Solution: C < A < B < D

Exercises 5.1

Order the following groups based on decreasing priority for E/Z naming purpose.

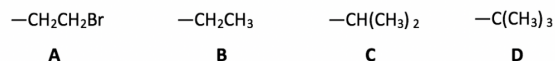

Answers to Practice Questions Chapter 5

4. When multiple bond is part of the group, the multiple bond is treated as if it was *singly* bonded to multiple of those atoms. Specifically:

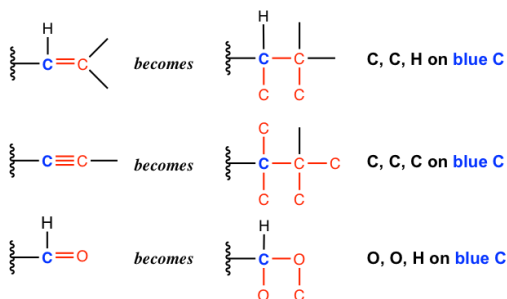

For these three groups involve multiple bonds, they all start with the carbon atom (the carbon atom highlighted in blue color), and we should compare the group of atoms that connected on the blue carbon by converting the multiple bond to “multiple single bonds”, as shown above. So, if we compare the order of these three groups, it is:

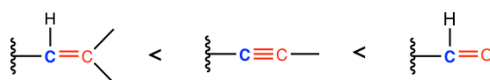

E/Z Assign of the double bond. Examples: circled

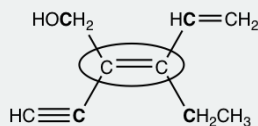

Thinking:

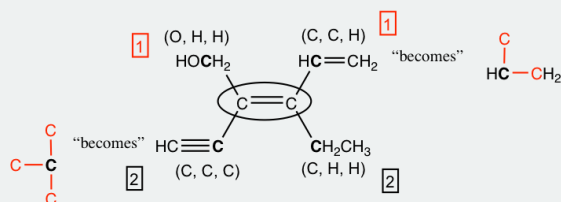

The answer is: Z-isomer.

This page titled 5.2: Geometric Isomers and E/Z Naming System is shared under a CC BY-NC-SA 4.0 license and was authored, remixed, and/or curated by Xin Liu (Kwantlen Polytechnic University).

5.3: Chirality and R/S Naming System

Other than geometric isomers, there is another type of stereoisomer that is related to a special property called chirality. We will start with the basic concepts of chirality, then expand the topic further from there.

5.3.1 Chiral and Chirality

To talk about chirality, let's first take a closer look at our hands, left hand and right hand. The left hand can be regarded as the mirror image of the right hand, and vice versa. Now let's try to superimpose (overlay) the left hand on right hand, can you do that?

No! No matter how hard you try, the left hand can not be superimposed on the right hand. This is because of the special property of hand, that is called **chirality**. Both left and right hand are **chiral** (ky-ral), and show **chirality**. Chiral derived from the Greek word *cheir*, that means "hand", and chirality means "handedness".

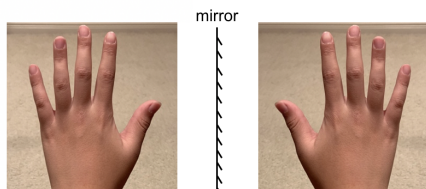

Figure 5.3a Left hand and right hand are non-superimposable mirror images

The definition of the **chirality** is **the property of any object (molecule) of being non-superimposable on its mirror image**. The left and right hand are mirror image to each other, and they are not superimposable, so both left hand and right hand are chiral. Other than that, you can also find lots other objects in daily life that show chirality as well.



Figure 5.3b Book is chiral

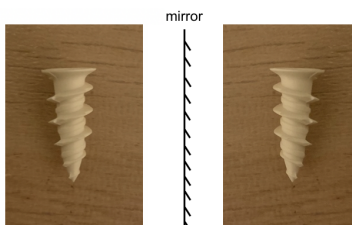

Figure 5.3c Screw is chiral

If an object is superimposable on its mirror image (for such case the object and its mirror image are exact identical), then this object is not chiral, that can be said as **achiral**.

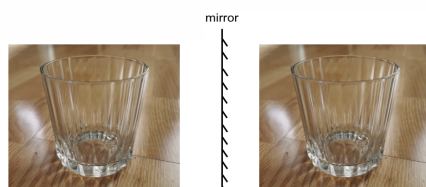

Figure 5.3d Cup is achiral

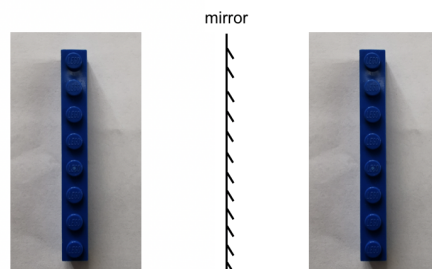
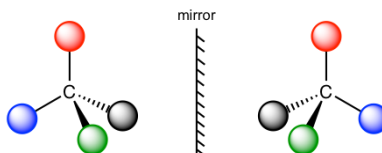

Figure 5.3e Lego piece is achiral

In organic chemistry, we are interested in organic molecules that are chiral. Let's see the following molecular models that represent a molecule and its mirror image.



In the models here, the four balls with different colors represent four different substituents, and the two structures are mirror image to each other. The effort of trying to superimpose one structure to the other does **not** work. Therefore, according to the definition of chiral/chirality, both molecules are non-superimposable on the mirror image, so they both chiral and show chirality.

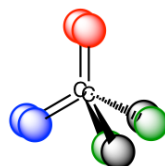

Figure 5.3f The two structures can not be superimposed to each other

The chirality of the molecule results from the structure of the central carbon. When the central carbon is sp^3 carbon, and bonded with four different groups (represented by four different colors in the model), the molecule is chiral. The central carbon is called **chirality center** (or **asymmetric center**). **The molecule with one chirality center must be chiral.** Chirality center can also be called asymmetric center. We will use the term chirality center in this book.

It is highly recommended that the **molecular model set** is used as learning tool in this chapter. Assemble the model as shown above to understand the concept of chiral and chirality. The model is also very useful for the R/S assignment later in this section.

As a summary, a chirality (asymmetric) center should meet two requirements:

- **sp^3 carbon;**
- **bonded with four different groups.**

Examples

For following compounds, label each of the chirality center with a star.

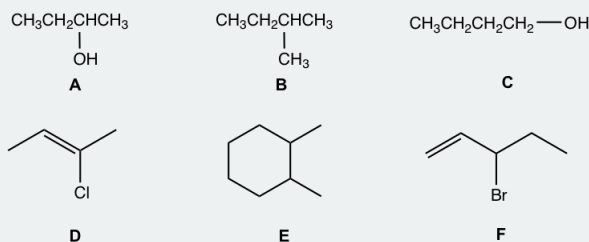

Approach:

- The carbons in CH_3 or CH_2 are NEVER chirality centers. The chirality center must be the carbon bonded with a branch (or branches).

- sp^2 double bond carbon is NEVER a chirality center.
- Carbon in a ring can also be chirality center as long as it meet the two requirements.
- Not all the above compounds have a chirality center.

Solution:

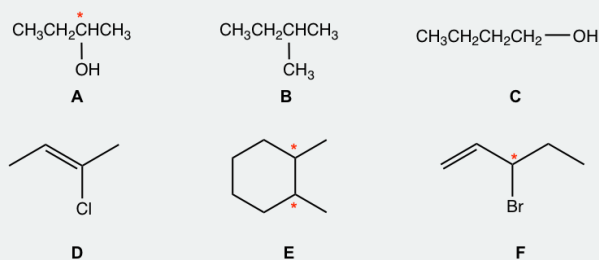

Exercises 5.2

1. Draw the structure of following compounds, determine which one has an chirality center and label it with a star.
 - a) 1-bromobutane,
 - b) 1-pentanol,
 - c) 2-pentanol,
 - d) 3-pentanol,
 - e) 2-bromopropanoic acid
 - f) 2-methyl cyclohexanone
2. Label all the chirality centers in the following molecules.

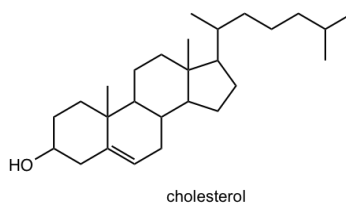

Answers to Practice Questions Chapter 5

5.3.2 Stereoisomer with One Chirality Center — Enantiomers

For 2-butanol, we are able to recognize that C2 is the chirality center.

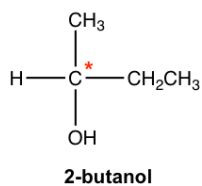

The perspective formula show the 3D structure of 2-butanol in two different ways, and they are non-superimposable mirror images to each other.

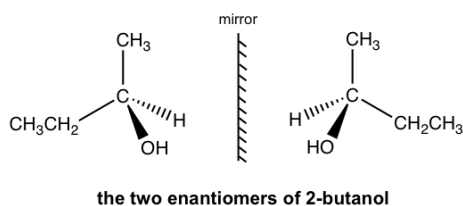

The two mirror images are different molecules. They have the same bonding, but differ in the way that the atoms arranged in space. So the two molecules are **stereoisomers**. This specific type of stereoisomer here is defined as **enantiomers**. Molecules that are a pair of non-superimposable mirror images of each other are called **enantiomers**.

Important Properties about Enantiomers:

- Enantiomers are a pair of non-superimposable mirror images.
- Enantiomers are a pair of molecules, they both chiral and show chirality. (**Enantiomer must be chiral**).
- For any chiral molecule, it must have its enantiomer, that is the mirror image to the molecule.
- Achiral molecule does not have enantiomer. The mirror image of an achiral molecule is the identical molecule to itself.

Draw the pair of enantiomers of 2-bromopropanoic acid. Examples:

Approach:

To draw the 3D structure of any enantiomer, we need to use **perspective formula** with solid and dashed wedges to show the tetrahedral arrangements of groups around the sp^3 carbon (refer to **section 2.11**). Out of the four bonds on tetrahedral carbon, two bonds lie within the paper plane are shown as ordinary lines, the solid wedge represent a bond that point out of the paper plane, and the dashed wedge represent a bond that point behind the paper plane. For the first enantiomer, you can draw the four groups with *any* arrangement, then draw the other enantiomer by drawing the *mirror image* of the first one. Please note, although it seems there are different ways to show the enantiomers, there are only total **two** enantiomers, we will learn in next section how to identify and designate each of them.

Several possible ways to show the structures are included in the answer here. However, **your answer can be different to any of them, as long as a pair of mirror images are shown**.

solution I:

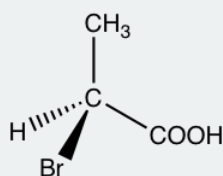
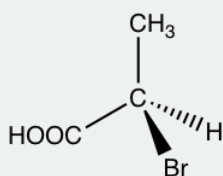

solution II:

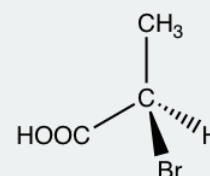
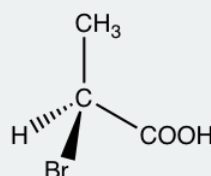

solution III:

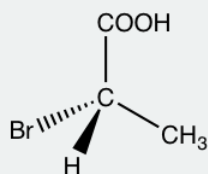
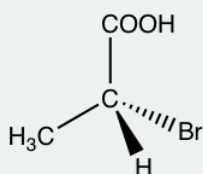

solution IV:

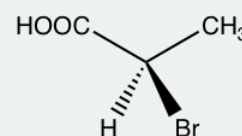
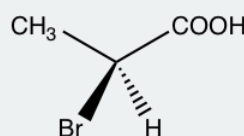

Exercises 5.3

Draw the pair of enantiomers of 2-chloro-1-propanol.

Answers to Practice Questions Chapter 5

5.3.3 R/S Naming System of Chirality Center

The two enantiomers are different compounds, although they are very similar. Therefore we need a nomenclature system to distinguish between them, to give each one a different designation so that we know which one we are talking about. That is the **R/S** naming system defined in IUPAC. The *R/S* designation can be determined by following the Cahn-Ingold-Prelog rule, the rule devised by R. S Cahn, C. Ingold and V. Prelog.

For a pair of enantiomers with one chirality center, one enantiomer has the *R* configuration and the other one has the *S* configuration.

Cahn-Ingold-Prelog Rule:

1. Assign priorities of the groups (or atoms) bonded to the chirality center by following the same priority rules as for *E/Z* system (section 5.2). **The highest priority group is labelled as #1, and lowest priority group labelled as #4 in this book.**
 2. Orient the molecule in the way that the lowest priority group (#4) pointing away from you.
- Look at the direction in which the priority decrease for the other three groups, that is 1 → 2 → 3.
 - For **clockwise** direction, designation is **R**-, *rectus*, means “right” in Latin.
 - For **counterclockwise** direction, designation is **S**-, *sinister*, means “left” in Latin.

Let's take the following molecule as an example to practice the rule:

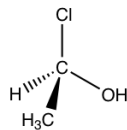

Step 1: The priorities are assigned.

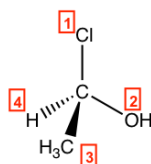

Step 2: Re-orient the molecule, so H (#4, lowest priority) is on the position away from us. Then the other three groups will be arranged in this way:

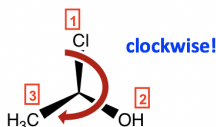

Step 3: Go along the direction from #1 → #2 → #3, it is in the clockwise direction, so this enantiomer is assigned **R** configuration, and the complete name of the molecule is **(R)-1-chloroethanol**.

Now let's assign the configuration of the other enantiomer:

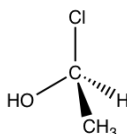

Following the same steps, put H away from us, and the arrangement of the other three groups is:

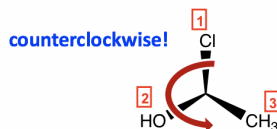

The counterclockwise direction gives the **S** configuration, and the complete name of the molecule is **(S)-1-chloroethanol**.

Assign R/S configuration of the chirality center. Examples:

1.

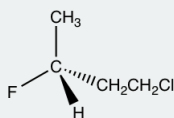

Solution:

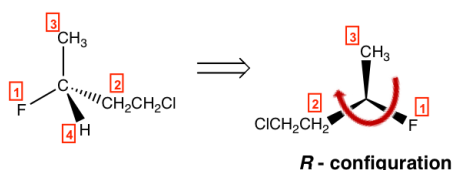

2.

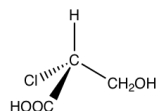

Solution:

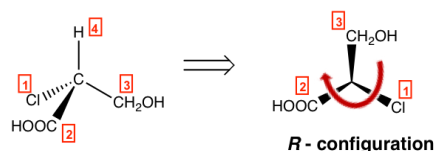

More **practical hints** about *R/S* assignment with Cahn-Ingold-Prelog rule:

- Assigning priority is the first possible challenge for applying the C.I.P. rule. Review and practice the guidelines in **section 5.2**.
- The 2nd challenge is to re-orient the molecule (to arrange the #4 group away from you). **The molecule model will be very helpful for this purpose**. Assemble a molecular model with four different colors connected on the carbon. Compare your model to the given structure and match the assigned priority to each color, for example, red is #1, blue is #2, etc. Then rotate the model to arrange the lowest (#4) group away from you and see how the other groups locate to get the answer.

For the perspective formula of enantiomers, it is important to know the following properties:

- One (odd number of) switch (interchanging) for a pair of groups invert the configuration of the chirality centre;
- Two (even number of) switches get the original configuration back.
-

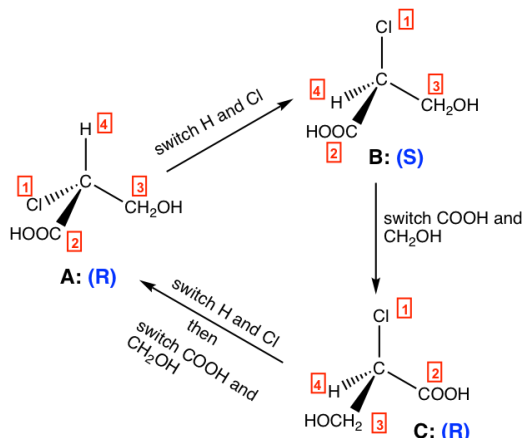

For the structures above:

- One switch of **A** leads to **B**, **A** is **R** and **B** is **S**, so **A** and **B** are **enantiomers**,
- One switch of **B** leads to **C**, **B** is **S** and **C** is **R**, so **B** and **C** are **enantiomers**,
- Two switches of **C** leads to **A**, both **C** and **A** are **R**, so **C** and **A** are **identical**.

When you switch between a pair of groups, do it with cautions. Do not switch unless it is really necessary because it is quite easy to get lost. Do *R/S* assignment is a safer (and easier for most cases) way to compare the relationship between two structures.

Exercises 5.4

Determine the *R/S* configuration of the chirality center in following compounds.

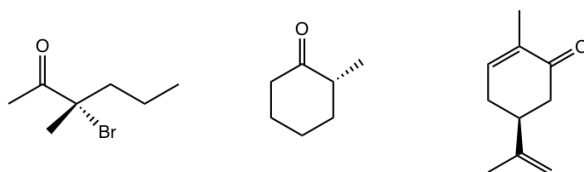

Answers to Practice Questions Chapter 5

Exercises 5.5

Determine the relationship for each pair of molecules: enantiomers, identical, constitutional isomers, non-isomer:

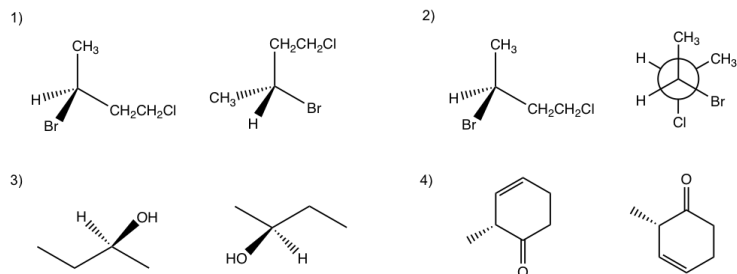

This page titled [5.3: Chirality and R/S Naming System](#) is shared under a [CC BY-NC-SA 4.0](#) license and was authored, remixed, and/or curated by [Xin Liu \(Kwantlen Polytechnic University\)](#).

5.4: Optical Activity

The two enantiomers are mirror images of each other. They are very alike and share many properties in common, like same b.p., m.p., density, color, solubility etc. In fact, the pair of enantiomers have the same physical properties **except** the way they interact with plane-polarized light.

In normal light, the electric field oscillates in all directions. When normal light passed through a polarizing filter, only light oscillating in one single plane can go through, and the resulting light that oscillates in one single direction is called plane-polarized light.

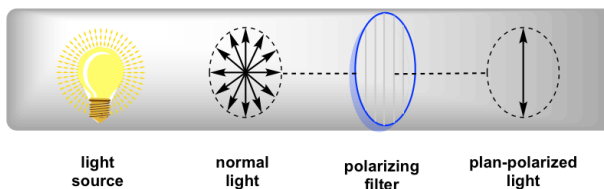

Figure 5.4a Generation of Plane-Polarized Light

When plane-polarized light interacts with chiral molecules, the plane of polarization will be rotated by the chiral substances. It was first discovered by Jean-Baptiste Biot in 1815 that some naturally occurring organic substances, like camphor, is able to rotate the plane of polarization of plane-polarized light. He also noted that some compounds rotated the plane clockwise and others counterclockwise. Further studies indicate that the rotation is caused by the chirality of substances.

The property of a compound being able to rotate the plane of polarization of plane-polarized light is called the **optical activity**, and the compound with such activity is labelled as **optical active**. The stereoisomer that is optical active is also called as **optical isomer**.

Chiral compound is optical active. Achiral compound is optical inactive.

The sample containing a chiral compound rotates the plane of polarization of plane-polarized light, the direction and angles of the rotation depends on the nature and concentration of the chiral substances. The rotation angles can be measured by using polarimeter (later in this section).

For a pair of enantiomers with same concentration, under the same condition, they rotate the plane of polarization with the **same angles** but in **opposite direction**, one is clockwise and the other is counterclockwise.

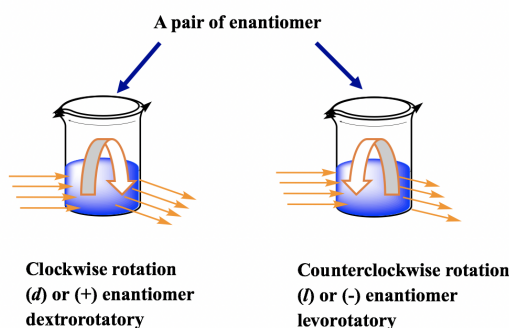
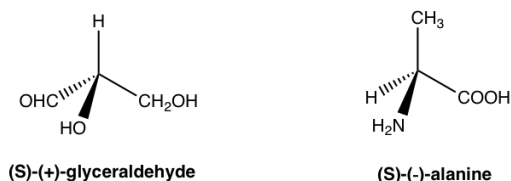

Figure 5.4b Clockwise rotation/enantiomer dextrorotatory vs. counterclockwise rotation/enantiomer levorotatory

The enantiomer rotates the plane of polarization clockwise is said to be **dextrorotatory** (*Latin*, means to the right), and labelled with the prefix (**d**) or (+). The enantiomer rotates the plane of polarization counterclockwise is said to be **levorotatory** (*Latin*, means to the left), and labelled with the prefix (**l**) or (-). The **d/l** (or +/-) indicate the direction in which an optical active compound rotates the plane of polarization of plane-polarized light, that has to be determined by experiment to measure the optical rotation. **d/l** (or +/-) **symbol has nothing to do with R/S**. R/S indicates the arrangement of the groups around the chirality center, that can be determined by knowing the exact spatial arrangement of the groups. That means compound with **R** configuration can be either **d** or **l**, and compound with **S** configuration can also be either **d** or **l**. For the examples below, both compounds are **S**-isomer, but one is **d** (+) and the other is **l** (-).



The only thing we can be sure is that for a pair of enantiomers, if one enantiomer has been determined as **d**, then the other enantiomer must be **l**, and vice versa.

Measurement of Optical Rotation

Polarimeter is the instrument that measures the direction and angles of rotation of plane-polarized light. The plane-polarized light pass through the sample tube containing the solution of sample, and the angle of rotations will be received and recorded by the analyzer, as summarized in **Fig. 5.4c**.

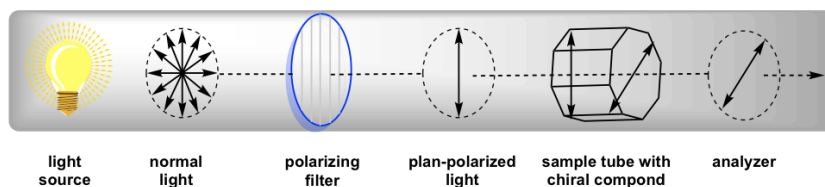

Figure 5.4c Measurement of Optical Rotation with Polarimeter

Since the measurement results vary with the wavelength of the light being used, the specific light from a sodium atomic spectrum with the wavelength of 589 nm, which is called the sodium D-line, is used for most polarimeter. The rotation degree measured by the polarimeter is called the **observed rotation** (α), and the observed rotation depends on the length of the sample tube, concentration of the sample and temperature.

To compare the optical rotation between different compounds under consistent conditions, the **specific rotation** $[\alpha]_D^{20^\circ C}$ ($[\alpha]_D^T$) is used. **Specific rotation** is the rotation caused by a solution with concentration of 1.0 g/mL in a sample tube of 1.0 dm length. The temperature is usually at 20°C. Based on this definition, the specific rotation can be calculated from the observed rotation by applying the formula:

$$[\alpha]_D^T = \frac{\alpha}{l \times c}$$

T: usually at 20 °C
 α : observed rotation in degree;
l: length of the sample cell (**dm**);
c: concentration (**g/mL**)

Figure 5.4d Specific rotation equation

Please note: In this formula, the unit of concentration (g/mL) and length of the sample tube (dm) are not the units we are familiar with. Also, the unit of the specific rotation is in degree (°), don't need to worry about **the units cancellation in this formula**.

Examples: Calculate the specific rotation

The observed rotation of 10.0g of (**R**)-2-methyl-1-butnaol in 50mL of solution in a 20-cm polarimeter tube is +2.3° at 20 °C, what is the specific rotation of the compound?

Solution

$$[\alpha]_D^{20^\circ C} = \frac{\alpha}{l \times c} = \frac{+2.3}{2dm \times \frac{10.0g}{50 mL}} = 5.75$$

Specific rotation is the characteristic property of an optical active compound. The literature specific rotation values of the authentic compound can be used to confirm the identity of an unknown compound. For the example here, if it has been measured that the specific rotation of (**R**)-2-methyl-1-butnaol is +5.75 °, then we can tell that the other enantiomer (**S**)-2-methyl-1-butnaol must have the specific rotation of -5.75 °, **without** further measurement necessary.

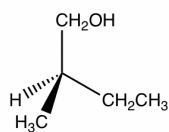

(R)-2-methyl-1-butanol

$$[\alpha]_D^{20^\circ\text{C}} = +5.75^\circ$$

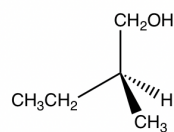

(S)-2-methyl-1-butanol

$$[\alpha]_D^{20^\circ\text{C}} = -5.75^\circ$$

Optical Activity of Different Samples

When a sample under measurement only contain one enantiomer, this sample is called as **enantiomerically pure**, means only one enantiomer is present in the sample.

The sample may also consists of a mixture of a pair of enantiomers. For such mixture sample, the observed rotation value of the mixture, together with the information of the specific rotation of one of the enantiomer allow us to calculate the percentage (%) of each enantiomer in the mixture. To do such calculation, the concept of enantiomer excess (**ee**) will be needed. The enantiomeric excess (**ee**) tells how much an excess of one enantiomer is in the mixture, and it can be calculated as:

$$ee = \frac{\text{observed rotation}}{\text{specific rotation of pure enantiomer}}$$

We will use a series of hypothetic examples in next table for detailed explanation.

If the specific rotation of a (+)-enantiomer is $+100^\circ$, then the observed rotation of the following samples are (assume the sample tube has the length of 1 dm, and the concentration for each sample is 1.0 g/mL):

Sample Number	Sample	Observed rotation ($^\circ$)
1	pure (+) enantiomer	+100
2	Pure (-)-enantiomer	-100
3	Racemic mixture of 50% (+)-enantiomer and 50% (-)-enantiomer	0
4	Mixture of 75% (+)-enantiomer and 25% (-)-enantiomer	+50
4	Mixture of 20% (+)-enantiomer and 80% (-)-enantiomer	-60

Sample #1 and **#2** are straightforward.

Sample #3 is for a mixture with equal amount of two enantiomers, and such mixture is called **racemic mixture** or **racemate**. Racemic mixtures do not rotate the plane of polarization of plane-polarized light, that means **racemic mixtures are optical inactive and have the observed rotation of zero!** This is because that for every molecule in the mixture that rotate the plane of polarization in one direction, there is an enantiomer molecule that rotate the plan of polarization in the *opposite* direction with the same angle, and the rotation get cancelled out. As a net result, no rotation is observed for the overall racemic mixture. The symbol (\pm) sometimes is used to indicate a mixture is racemic mixture.

Sample #4, the (+)-enantiomer is in excess. Since there are 75% (+)-enantiomer and 25%(-)-enantiomer, the enantiomeric excess (**ee**) value of (+)-enantiomer is $75\% - 25\% = 50\%$, this can also be calculated by the formula: $ee =$

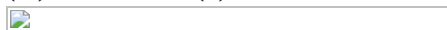

In this sample of mixture, the rotation of the (-)-enantiomer is *cancelled* by the rotation caused by part of the (+)-enantiomer, so the overall net observed rotation depends on how much “net amount” of (+)-enantiomer present. This can be shown by the diagram below that helps to understand.

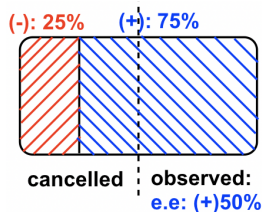

Figure 5.4e Cancelled & observed

Sample #5, the (-)-enantiomer is in excess, and because there is 80% (-)-enantiomer and 20% (+)-enantiomer, the enantiomeric excess (ee) value of (-)-enantiomer is $80\% - 20\% = 60\%$, this can also be calculated by the formula: ee =



Please note: to calculate the e.e value, it is not necessary to include the sign of the rotation angle, as long as *keep in mind* that the sign (+ or -) of the observed rotation indicates that which enantiomer is in excess.

Exercises 5.6

Draw the diagram for **Sample #5** by referring to the diagram for **Sample #4**.

[Answers to Practice Questions Chapter 5](#)

Examples: An advanced level of calculation

The (+)-enantiomer of a compound has specific rotation ($[\alpha]^{20}_D$) of $+100^\circ$. For a sample (1 g/ml in 1dm cell) that is a mixture of (+) and (-) enantiomers, the observed rotation α is -45° , what is the percentage of (+) enantiomer present in this sample?

Solution

The observed rotation is in “-”, so (-)-enantiomer is in excess.

ee of (-)-enantiomer is:



From here, we will see two ways of solving such type of question:

Method I: solving algebra

% of (-)-enantiomer is set as “x”; % of (+)-enantiomer is set as “y”

$$x + y = 100\%$$

$$x - y = 45\%$$

Solve $x = 72.5\%$; $y = 27.5\%$;

So there is 72.5% (-)-enantiomer and 27.5% of (+)-enantiomer in the sample.

Method II: using diagram, the answer is in blue color, there is 27.5% of (+)-enantiomer.

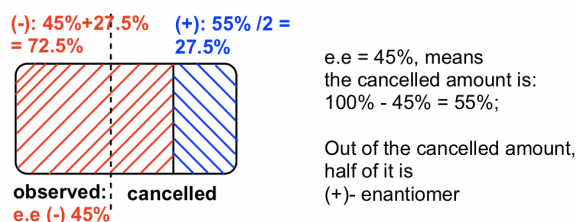

Chirality and Biological Properties

Other than optical activity difference, the different enantiomers of a chiral molecule usually show different properties when interacting with other chiral substances. This can be understood by using the analogue example of fitting a hand into the respective glove: right hand only fits into right glove, and it feels weird and uncomfortable if you wear left glove on the right hand. This is because both right hand and right glove are chiral. A chiral object only fit into a specific chiral environment.

In human body, the biological functions are modulated by a lot of enzymes and receptors. Enzymes and receptors are essentially proteins, and proteins are made up of amino acids. Amino acids are examples of naturally exist chiral substances. With the general formula given below, the carbon with amino (NH_2) group is the chirality (asymmetric) center for most amino acids, and only one enantiomer (usually *S*-enantiomer) exist in nature. A few examples of amino acids are given below with the general formula.

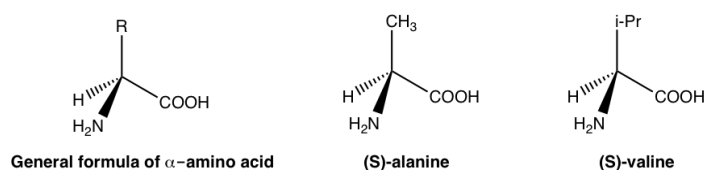

Figure 5.4f Chirality center of amino acids

Because amino acids are chiral, proteins are chiral so enzymes and receptors are chiral as well. The enzyme or receptor therefore form the chiral environment in human body that distinguish between *R* or *S* enantiomer. Such selectivity can be illustrated by the simple diagram below.

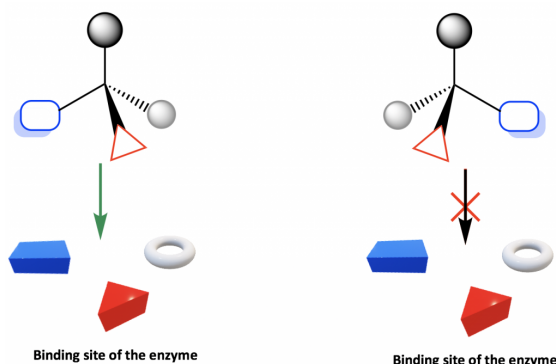
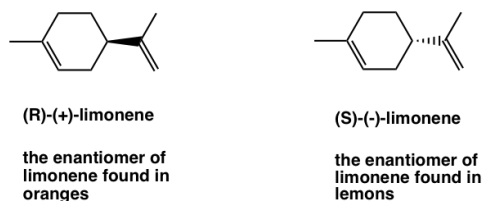

Figure 5.4g Binding site of the enzyme

The binding site of enzyme or receptor is chiral, so it only binds with the enantiomer whose groups are in the proper positions to fit into the binding site. As shown in the diagram, only one enantiomer binds with the site, but not the other enantiomer.

A couple of common examples to showcase such binding selectivity of different enantiomer may include limonene and carvone.

Limonene has two enantiomers, and they smell totally different to human being because they interact with different receptors that located on the nerve cells in nose. The (*R*)-(+)-limonene is responsible for the smell of orange, and the (*S*)-(-)-limonene gives the bit smell of lemon.



If you like caraway bread, that is due to the (*S*)-(+)-carvone; and the (*R*)-(-)-carvone that is found in spearmint oil gives much different odor.

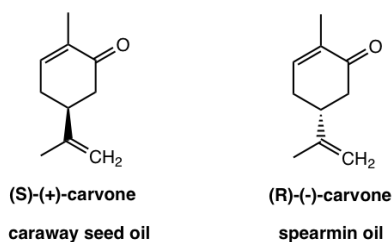

More dramatic examples of how chirality plays important role in biological properties are found in many medicines. For the common over-the-counter anti-inflammatory drug ibuprofen (Advil), for example, only (*S*)-enantiomer is the active agent, while the (*R*)-enantiomer has no anti-inflammatory action. Fortunately, the (*R*)-enantiomer does not have any harmful side effect and slowly converts to the (*S*)-enantiomer in the body. The ibuprofen is marketed usually as a racemate form.

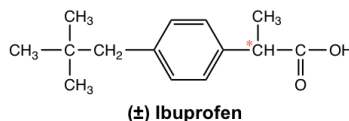

The issue of chiral drugs (the drug contain a single enantiomer, not as a racemate) was not in the attention of drug discovery industry until 1960. Back then, drugs were approved in racemate form if a chirality center involved, and there was no further study about biological difference on different enantiomers. These were all changed by the tragic incident of thalidomide. Thalidomide was a drug that was sold in more than 40 countries, mainly in Europe, in early 1960s as a sleeping aid and to pregnant women as antiemetic (drug that preventing vomiting) to combat morning sickness. It was not recognized at that time that only the *R*-enantiomer has the property, while the *S*-enantiomer was a teratogen that causes congenital deformations. The drug was marketed as a racemic mixture and caused about 10,000 children had been damaged until it was withdrawn from the market in Nov. 1961. This drug was not approved in US however, attributed to Dr. Frances O. Kelsey, who was a physician for the FDA (Food and Drug Administration) at that time and had insisted on additional tests on some side effects. Thousands of life were saved by Dr. Kelsey, and she was awarded the President's medal in 1962 for preventing the sale of thalidomide.

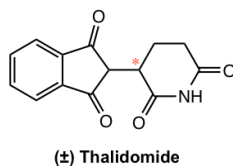

This page titled [5.4: Optical Activity](#) is shared under a [CC BY-NC-SA 4.0](#) license and was authored, remixed, and/or curated by [Xin Liu](#) ([Kwantlen Polytechnic University](#)).

5.5: Fisher Projection

For the discussions so far, the perspective formula with solid and dashed wedges have been used to represent the 3D arrangement of groups bonded to a chirality center. Other than that, there is another broadly applied formula for that purpose, that is the Fisher projection. A Fisher projection is a shortcut for showing the spatial group arrangement of a chirality center, it is more easily to be drawn and recognized, and is particularly useful for showing the structures with more than one chirality centers.

In Fisher projection, the chirality center is shown as the intersection of two perpendicular lines. **The horizontal lines represent the bonds point out of the plane, and the vertical lines represent the bonds that point behind the plane.**

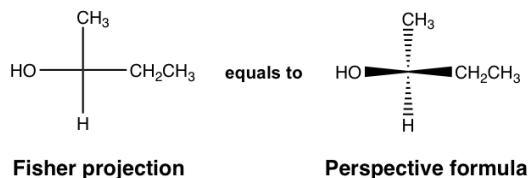

It is very important to keep in mind that the lines in Fisher projection are not just bonds, they represent the bonds with specific spatial arrangements and stereochemistry.

Assigning R/S Configuration in Fisher projection

Taking the following compound as an example:



1. Assign group priority as we usually do.

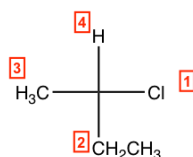

2. If the lowest priority group (#4 group) is on a **vertical** bond, determine the priority decrease direction from #1 → #2 → #3 as usual to get the configuration, clockwise is **R** and counterclockwise is **S**.
- 3.

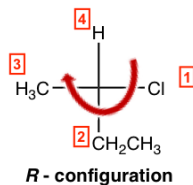

So, the example here is a **R**-isomer, and the complete name of the compound is (**R**)-2-chlorobutane.

3. If the lowest priority group is on a **horizontal** bond (as the case in the following structure), determine the priority decrease direction as in step 2, then **reverse the answer to opposite** way, to get the final configuration.

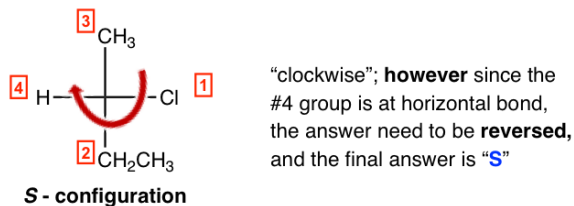

So, the example here is a **S**-isomer, and the complete name of the compound is (**S**)-2-chlorobutane.

Exercises 5.6

Explain that why in step 3 of the above procedure, the answer should be **reversed** to get the final (actual) configuration?

Answers to Practice Questions Chapter 5

Exercises 5.7: Indicate the configuration of the following structures.

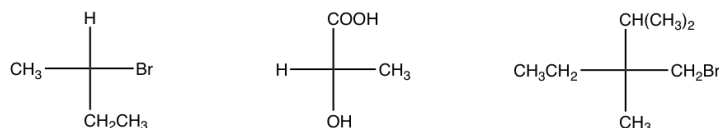

Properties of Fisher projection:

1. One switch (interchange) of two groups in a Fisher projection invert the configuration, two switches bring the original isomer back.

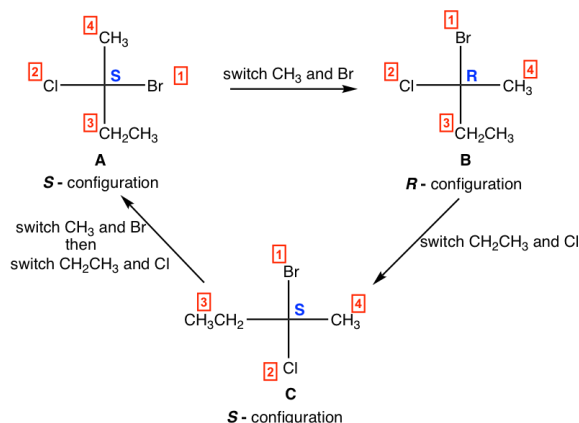

For above structures:

- one switch of **A** leads to **B**, **A** and **B** are enantiomers;
- one switch of **B** leads to **C**, **B** and **C** are enantiomers;
- two switches of **C** leads to **A**, **A** and **C** are identical.

2. Rotate the Fisher projection 180° get same structure, with the configuration retained.

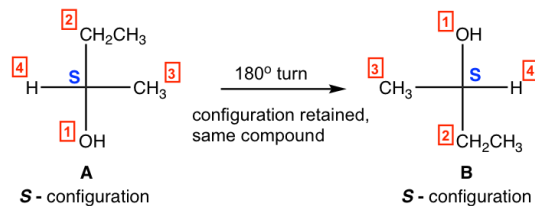

- 180° rotation of **A** leads to **B**, **A** and **B** are identical.

3. Rotate the Fisher projection 90° get the configuration inverted.

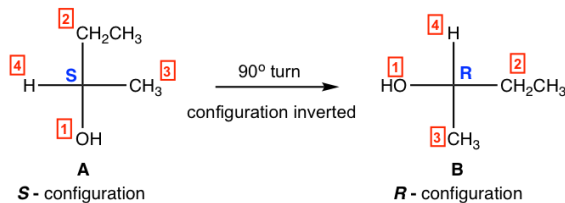

- 90° rotation of **A** leads to **B**, **A** and **B** are enantiomers.

Do NOT rotate the Fisher projection 90° , unless you have to. Keep in mind that the configuration get inverted by 90° rotation.

This page titled [5.5: Fisher Projection](#) is shared under a [CC BY-NC-SA 4.0](#) license and was authored, remixed, and/or curated by [Xin Liu](#) ([Kwantlen Polytechnic University](#)).

5.6: Compounds with More Than One Chirality Centers

5.6.1 Diastereomers

It is very common that there are more than one chirality centers in an organic compound. For the example of 2-bromo-3-chlorobutane below, there are 2 chirality centers, C2 and C3. With each chirality center has two possible configurations, **R** and **S**, the total number of possible stereoisomers for this compound is four, with configurations on C2 and C3 as **RR**, **SS**, **RS** and **SR** respectively.

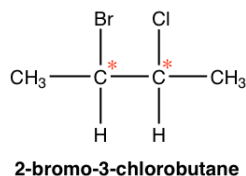

As a general rule, for a compound has n chirality centers, the **maximum** number of stereoisomers for that compound is 2^n .

The four stereoisomers of 2-bromo-3-chlorobutane consist of two pairs of enantiomers. Stereoisomers **A** and **B** are a pair of non-superimposable mirror images, so they are enantiomers. So are the isomers **C** and **D**. Then what is the relationship between isomer **A** and **C**?

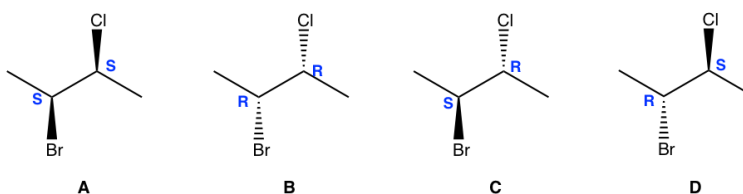

Four stereoisomers of 2-bromo-3-chlorobutane in perspective formula

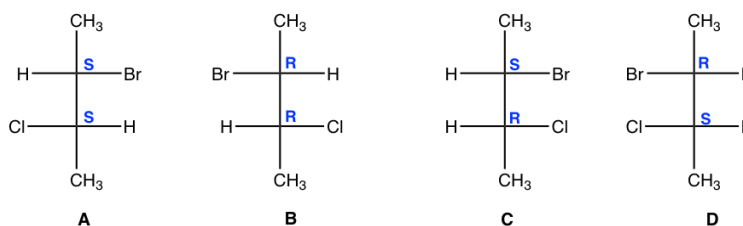

Four stereoisomers of 2-bromo-3-chlorobutane in Fisher projection

A and **C** are not identical, not enantiomers, and they are stereoisomers (have the same bonding but differ in the spatial arrangement of groups). Such type of stereoisomers are defined as **diastereomers**. **Diastereomers** are stereoisomers that are not enantiomers. For the four stereoisomers here, there are four pairs of diastereomers: **A** and **C**, **A** and **D**, **B** and **C**, **B** and **D**. The relationship between the four stereoisomers can be summarized as:

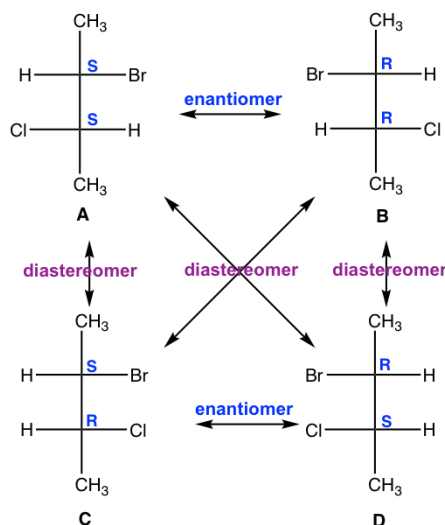

Relationships between the four stereoisomers of 2-bromo-3-chlorobutane

With the introduction of diastereomer concept, the way to categorize isomers can be revised, and the summary in **Fig. 5.1a** can be replaced by the updated version in **Fig. 5.6a**. The stereoisomer then has two sub-types, enantiomers and diastereomers, because **any stereoisomers that are not enantiomers can always be called diastereomers**. Based on such definition, the geometric isomers we learned earlier also belong to the diastereomer category.

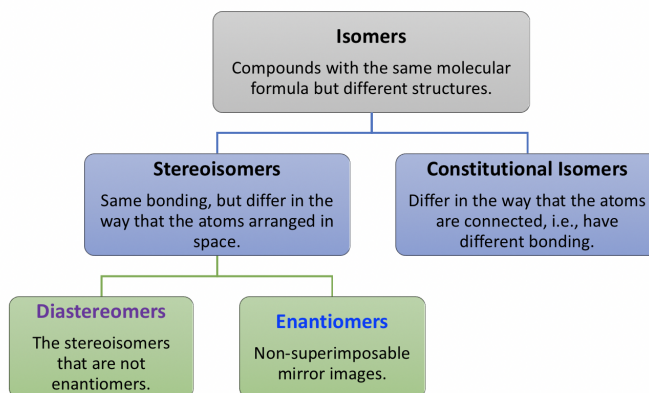
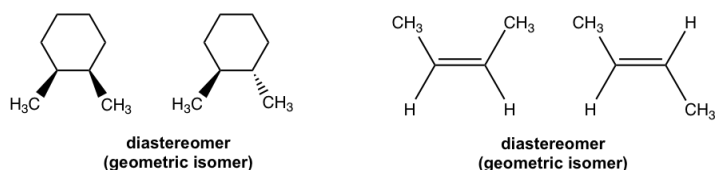

Figure 5.6a Updated Summarization of isomers

As mentioned earlier, enantiomers are very alike to each other, and they share same physical properties except optical activity (opposite sign for specific rotation). Enantiomers also generally have same chemical properties, except the reaction with other chiral reagents (not topics in this course).

However, diastereomers are not that closely related. Diastereomers have different physical properties, for example, different b.p, color, density, polarity, solubility etc. They also have different chemical properties.

Next, we will go through the examples of cyclic compounds, to see how the new concept of diastereomer relates to the knowledge about cyclic compounds we learned before.

Examples Draw the structures of all the stereoisomers for 1-bromo-2-chlorocyclobutane, and indicate the relationship between any two stereoisomers.

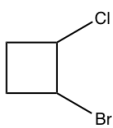

1-bromo-2-chlorocyclobutane

Approach:

There are two chirality centers for 1-bromo-2-chlorocyclobutane molecule. So the maximum number of stereoisomer is four. To work on the stereoisomers for cyclic compound, we can start with *cis*/*trans* isomer, and then check does the enantiomer apply to each case.

Solution:

cis-1-bromo-2-chlorocyclobutane:

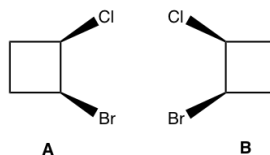

trans-1-bromo-2-chlorocyclobutane:

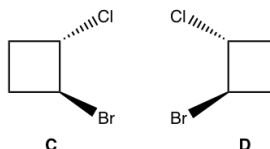

There are two *cis*-isomers, **A** and **B**, and they are enantiomers of each other; similarly, there are also two *trans*-isomers **C** and **D** that are enantiomers of each other as well.

The relationship between *any* of the *cis*-isomer to *any* of the *trans*-isomer is **diastereomers** (**A** and **C**, **A** and **D**, **B** and **C**, **B** and **D**). Since they are geometric isomers, and remember that the geometric isomers can also be called diastereomers.

All geometric isomers are diastereomers (it is always correct to call a pair of geometric isomers as diastereomers), however not all the diastereomers are geometric isomers!

Examples:

What is the relationship between the following pair of compounds, enantiomers, identical, diastereomers, constitutional isomers, non-isomers?

1.

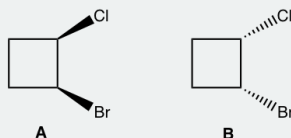

Method I: The basic way is to determine the configuration of each chirality center. As shown below that the configuration for both chirality centres are right opposite between the structure **A** and **B**. So they are enantiomers.

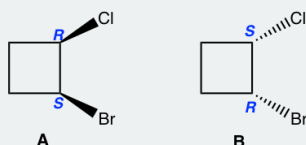

Method II: For the cyclic structures, sometimes rotate or flip a given structure in a certain way helps us to tell the relationship (using the molecular model helps the rotate or flip part). For this example, flipping structure **B** horizontally leads to structure

C, B and C are identical. Then it is easy to tell that A and C are just non-superimposable mirror images to each other, so A and C are enantiomers, then A and B are enantiomers as well.

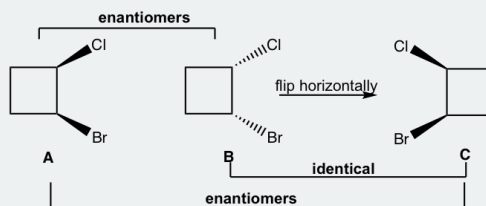

If this method looks confusing to you, then you can stick to **Method I**.

2.

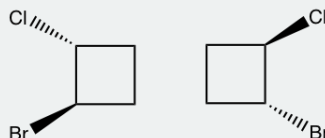

You can use either of the above methods, the answer is “identical”.

5.6.2 Meso compound

Next, we will see another example of a compound containing two chirality centers, 2,3-dichlorobutane, the compound that has the same substituents on C2 and C3 carbons.

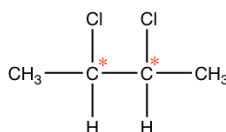

2,3-dichlorobutane

Theoretically, there are *maximum* four stereoisomers, the structures are shown by Fisher projections here.

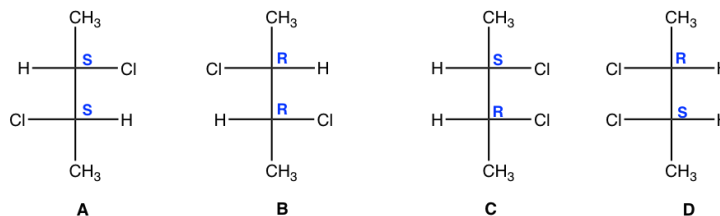

Stereoisomer **A** and **B** are non-superimposable mirror images, so they are enantiomers.

We will take a detailed look at stereoisomer **C** and **D**. Yes, they are mirror images, but are they really non-superimposable? If isomer **C** is rotated 180° (180° rotation still get the same structure back for Fisher projection), then it could get superimposed on isomer **D**. So, isomer **C** and **D** are superimposable mirror images, that means they are the same, **identical!**

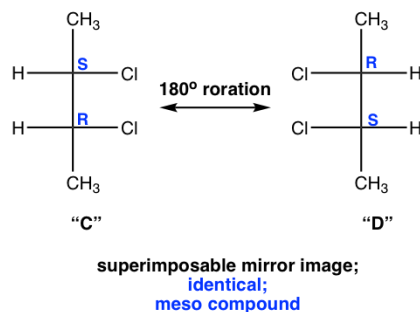

Then “C” and “D” are just different drawings for the same stereoisomer. The next question is, is this stereoisomer chiral? We have confirmed that this isomer does get superimposed on its mirror image, that means it is **achiral**.

This is so weird! How come a compound that contains two chirality centers (C2 and C3) is achiral?

Yes, it does happen! A compound that is achiral but contains chirality centers is called **meso compound**. A meso compound is **achiral and optically inactive** (does **NOT** rotate the plane of polarization of plane-polarized light), but it does have multiple chirality centers.

Because that one stereoisomer is a meso compound, the total number of stereoisomers for 2,3-dichlorobutane is **three**.

Attention, 2^n is the **maximum** number of stereoisomers. Some compounds may have **less** than the maximum, because of the existence of meso compounds.

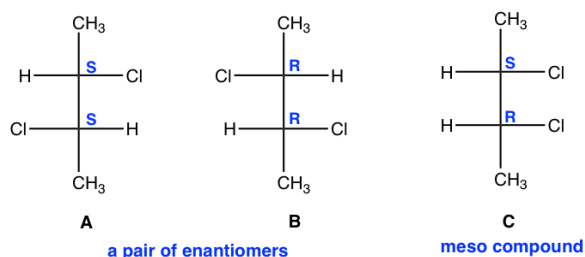

Three stereoisomers of 2,3-dichlorobutane

Examples: Draw all the stereoisomers of 1,2-dibromocyclopentane.

Solutions: there are total three stereoisomers.

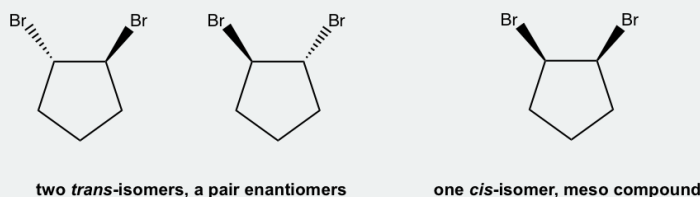

Exercises 5.8

- Draw all stereoisomers for 1-ethyl-3-methylcyclohexane.
- Draw all stereoisomers for 1-ethyl-4-methylcyclohexane.
- Draw all stereoisomers for 1,2-dimethylcyclohexane.

Answers to Practice Questions Chapter 5

5.6.3 Chiral or achiral by looking for Plane of symmetry

The existence of chirality centers does not guarantee the chirality of a molecule, for example of the meso compound. Following the definition of chirality always involves the comparison between original structure and its mirror image, that needs extra work. Is there any easier way to tell whether a molecule is chiral or achiral?

We can check the **plane of symmetry**. Plane of symmetry is a plane that cuts the molecule in half and that one half is the mirror image of the other.

- **If a molecule does have a plane of symmetry, then the molecule is achiral.**
- **The molecule that does not have a plane of symmetry in any conformation is chiral.**

For the meso isomer of 2,3-dichlorobutane, the plane of symmetry is the plane that is labeled in the structure below.

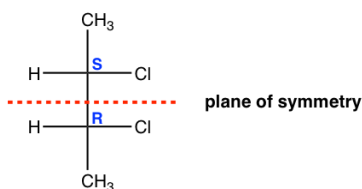

Examples: Determine whether the following molecule is chiral or achiral.



Solution:

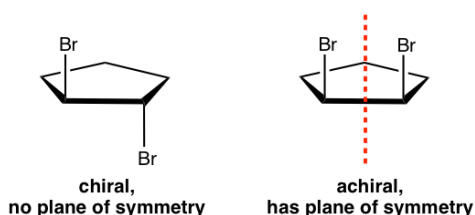

Checking the plane of symmetry provides a quick way to determine the chirality of a molecule. But sometimes you may need to look for the proper conformation to get the plane of symmetry. See following example.

Examples: What is the relationship of the following pair of structures?

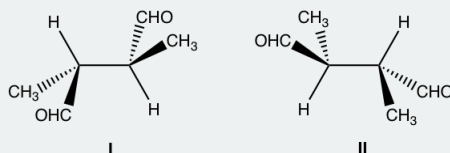

Approach: Determine the R/S configuration of each carbon.

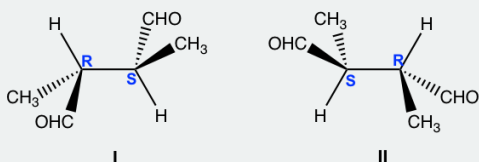

For both structures, the chirality centres are bonded with the same groups, and structure **I** has **R** and **S**, structure **II** has **S** and **R**. Are they enantiomers?

A bit further investigation is necessary to get the conclusion. Let's rotate the groups around the 2nd chirality centre of structure **I** (you can use the molecular model to do the rotation, that is very helpful for visualizing the spatial arrangement of the groups):

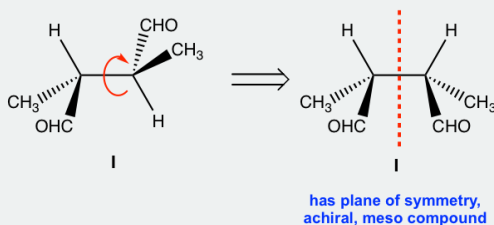

Rotation of the groups around the chirality centre does not change the configuration, however it does change the conformation to eclipsed conformation. In the eclipsed conformation, it is easier to tell that the structure has a plane of symmetry, so it is a

meso compound that is achiral. Achiral compound does not have enantiomer, so **structure II is also meso compound that is identical to structure I.**

Solution: Identical

(You can rotate, or do switches to compare between the two structures, but make sure to keep track on any action. If it is easy to get lost by rotating or switch, assign R/S configuration is a safer way.)

Examples

If the specific rotation of this molecule is $+50^\circ$ (hypothetic value), determine the specific rotation of molecules in following questions:

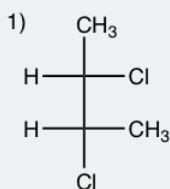
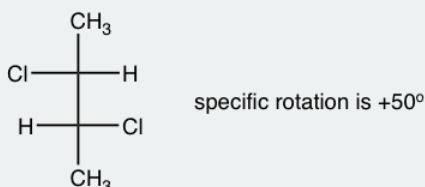

- a) $+50^\circ$
- b) -50°
- c) 0°
- d) not enough information to decide

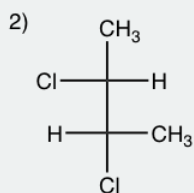

- a) $+50^\circ$
- b) -50°
- c) 0°
- d) not enough information to decide

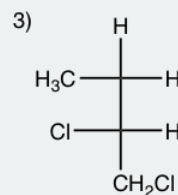

- a) $+50^\circ$
- b) -50°
- c) 0°
- d) not enough information to decide

Thinking: Determine the relationship between the molecule in each question with the given one, and apply the knowledge of specific rotation.

Solutions:

If the specific rotation of this molecule is $+50^\circ$ (hypothetic value), determine the specific rotation of molecules in following questions:

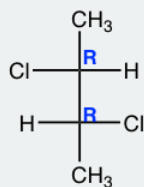

specific rotation is $+50^\circ$

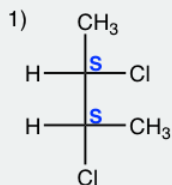

- a) $+50^\circ$
 b) -50°
 c) 0°
 d) not enough information to decide

this molecule is **enantiomer** to the given molecule, so the specific rotation has the same value, but opposite sign

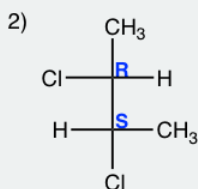

- a) $+50^\circ$
 b) -50°
 c) 0°
 d) not enough information to decide

this molecule is **diastereomer** to the given molecule, and it is a meso compound, so **achiral**

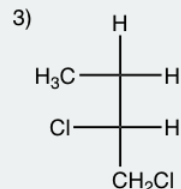

- a) $+50^\circ$
 b) -50°
 c) 0°
 d) not enough information to decide

this molecule is **constitutional isomer** to the given molecule, so the specific rotation has no connection to each other

This page titled [5.6: Compounds with More Than One Chirality Centers](#) is shared under a [CC BY-NC-SA 4.0](#) license and was authored, remixed, and/or curated by [Xin Liu \(Kwantlen Polytechnic University\)](#).

5.7: Answers to Practice Questions Chapter 5

5.1 Order the following groups based on decreasing priority for E/Z naming purpose.



Answer: $\text{D} > \text{C} > \text{A} > \text{B}$

5.2

1. Draw the structure of following compounds, determine which one has an chirality center and label it with a star.

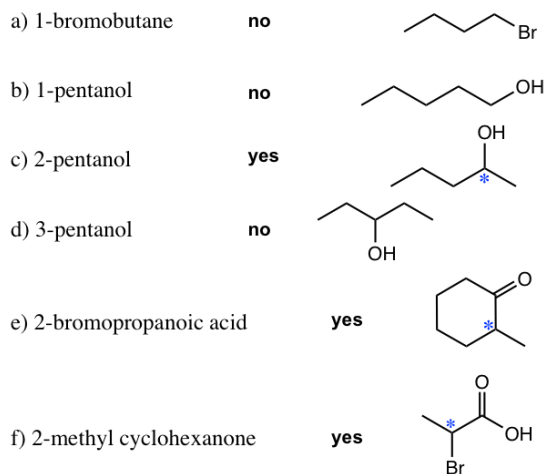

2. Label all the chirality centers in the following molecules.

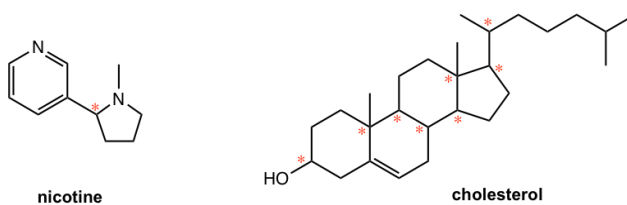

5.3 Draw the pair of enantiomers of 2-chloro-1-propanol.



5.4 Determine the R/S configuration of the chirality center in following compounds.

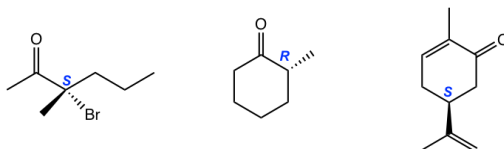

5.5 Determine the relationship for each pair of molecules: enantiomers, identical, constitutional isomers, non-isomer:

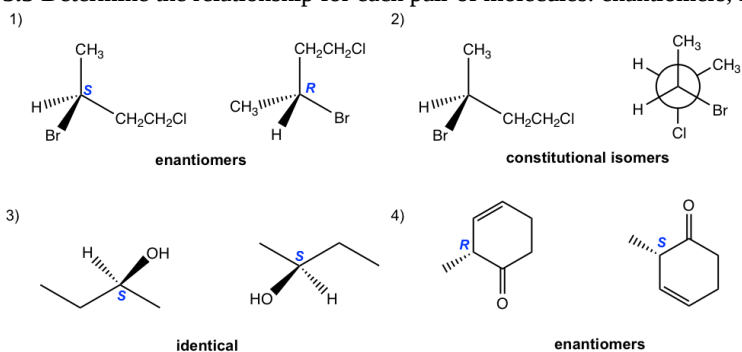

5.6 Draw the diagram for **Sample #5** by referring to the diagram for Sample #4.

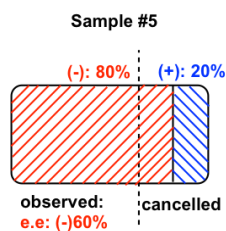

5.7 Explain that why in step 3 of the above procedure, the answer should be **reversed** to get the final (actual) configuration?

According to the definition of Fisher projection, the horizontal bond is the bond pointing towards the viewer. Therefore when the lowest priority group is on a horizontal bond, it is on the position just **opposite** to the way defined by the Cahn-Ingold-Prelog rule, so the actual configuration should be the reversed version of whatever obtained initially.

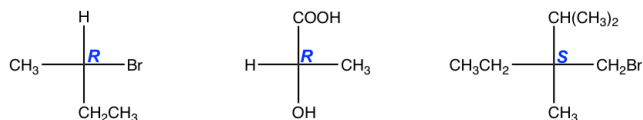

5.8 Indicate the configuration of the following compounds.

5.9

- Draw all stereoisomers for 1-ethyl-3-methylcyclohexane.

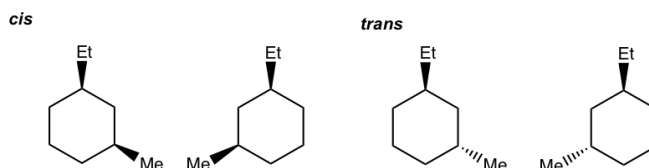

- Draw all stereoisomers for 1-ethyl-4-methylcyclohexane.

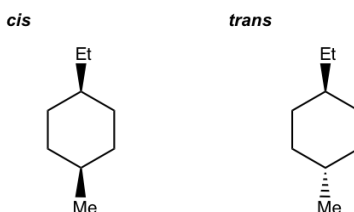

- Draw all stereoisomers for 1,2-dimethylcyclohexane.

cis

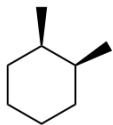

meso compound

trans

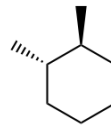
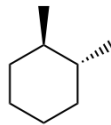

This page titled [5.7: Answers to Practice Questions Chapter 5](#) is shared under a [CC BY-NC-SA 4.0](#) license and was authored, remixed, and/or curated by [Xin Liu \(Kwantlen Polytechnic University\)](#).

CHAPTER OVERVIEW

6: Structural Identification of Organic Compounds- IR and NMR Spectroscopy

6.1: Electromagnetic Radiation and Molecular Spectroscopy

6.2: Infrared (IR) Spectroscopy Theory

6.3: IR Spectrum and Characteristic Absorption Bands

6.4: IR Spectrum Interpretation Practice

6.5: NMR Theory and Experiment

6.6: ^1H NMR Spectra and Interpretation (Part I)

6.7: ^1H NMR Spectra and Interpretation (Part II)

6.8: ^{13}C NMR Spectroscopy

6.9: Structure Determination Practice

6.10: Answers to Practice Questions Chapter 6

This page titled [6: Structural Identification of Organic Compounds- IR and NMR Spectroscopy](#) is shared under a [CC BY-NC-SA 4.0](#) license and was authored, remixed, and/or curated by [Xin Liu \(Kwantlen Polytechnic University\)](#).

6.1: Electromagnetic Radiation and Molecular Spectroscopy

Electromagnetic radiation is the radiation composed of oscillating electrical and magnetic fields. The whole electromagnetic spectrum covers the radiation in very broad range from gamma rays (emitted by the nuclei of certain radioactive elements), X-rays (used for medical examination of bones), to ultraviolet (UV) light (is responsible for sunburn, can also be used for disinfection purpose), microwaves, and radio-frequency waves (used for radio and television communication, and of the cell phone signal). Visible light, the radiation that is visible to our bare eyes and what we commonly refer to as “light”, just accounts for a very narrow band out of the full electromagnetic spectrum.

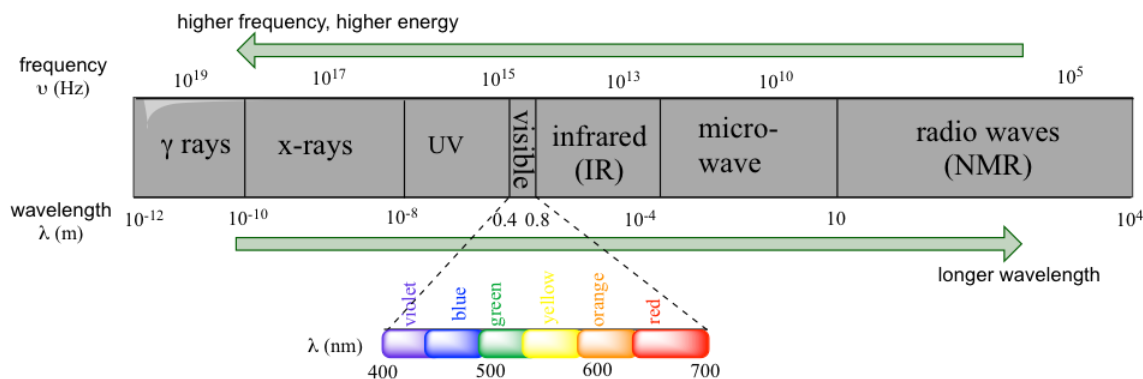

Figure 6.1a The Electromagnetic Spectrum

Electromagnetic radiation exhibits wave-like properties. As a general property of waves, the **wavelength** (λ , Greek ‘lambda’) and **frequency** (ν , Greek ‘nu’, in unit of Hz or s^{-1} , $1\text{Hz} = 1s^{-1}$) of electromagnetic radiation fits in the formula of:

$$c = \lambda\nu \text{ Formula 6.1}$$

where c is the speed, usually referred to as the “speed of light”, with the constant value of $2.998 \times 10^8 \text{m/s}$ in vacuum (the speed of light in air is a little bit slower than this constant but is usually regarded as the same). Because electromagnetic radiation travels at a constant speed, wavelength (λ) and frequency (ν) are inversely proportional to each other, **the longer waves have lower frequencies, and shorter waves have higher frequencies.**

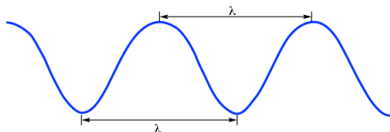

Figure 6.1b Wavelength

The energy of electromagnetic radiation can be calculated based on formula:

$$E = h\nu = hc/\lambda \text{ Formula 6.2}$$

where E is energy of each photon in unit of Joule (J) and h is the **Planck’s constant** with value of $6.626 \times 10^{-34} \text{J}\cdot\text{s}$.

So radiations with higher frequencies correspond to higher energy. High energy radiation, such as gamma radiation and X-rays, is composed of very short waves – as short as 10^{-16}m . Longer wavelengths are much less energetic, and thus are less harmful to living things. Visible light waves are in the range of 400 – 700 nm (nanometer, $1\text{nm} = 10^{-9} \text{m}$), while radio waves can be several hundred meters in length.

In a molecular spectroscopy experiment, electromagnetic radiation of a specified range of wavelengths is allowed to pass through a sample containing a compound of interest. The sample molecules absorb energy from some of the wavelengths, and as a result jump from a lower energy ‘ground state’ to some higher energy ‘excited state’. Other wavelengths are *not* absorbed by the sample molecule, so they pass on through. A detector records which wavelengths were absorbed, and how much were absorbed.

As we will see in this chapter, we can learn a lot about the structure of an organic molecule by quantifying how it absorbs (or does not absorb) different wavelengths in the electromagnetic spectrum. The IR spectroscopy involves absorption of radiation in the infrared region and radio waves are applied in the NMR technique.

This page titled [6.1: Electromagnetic Radiation and Molecular Spectroscopy](#) is shared under a [CC BY-NC-SA 4.0](#) license and was authored, remixed, and/or curated by [Xin Liu \(Kwantlen Polytechnic University\)](#).

6.2: Infrared (IR) Spectroscopy Theory

In IR spectroscopy, how the vibration mode of covalent bonds are affected by absorbing the infrared electromagnetic radiation is studied. Covalent bonds in organic molecules are not rigid sticks, they behave as if they were vibrating springs instead. At room temperature, organic molecules are always in motion that involves several vibration modes, such as stretching, bending, and twisting as illustrated in **Fig. 6.2a**.

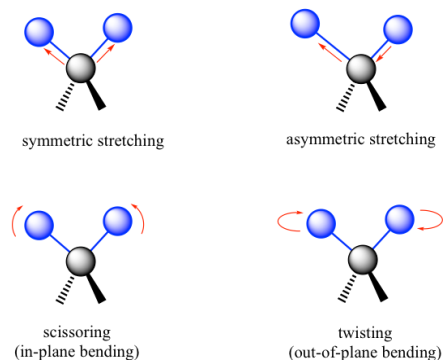

Figure 6.2a Vibration Modes of Bonds

Stretching is the vibration occurring along the line of the bond that changes the bond length. Bending is the vibration that like swing, it does not occur along the line, but change the bond angles. The specific bending mode are often referred to by the descriptive terms like scissoring, twisting etc.

One covalent bond may vibrate in different vibrational modes, for example, the C-H bond can be in stretching and bending mode. Each vibrational mode for a given bond occurs with a characteristic ground state frequency, that corresponds to the frequency of infrared region (10^{13} to 10^{14} Hz, or 2.5 to 17 μm in wavelength) of the electromagnetic spectrum. If a molecule is exposed to infrared radiation, it will absorb the radiation that matches the frequency of the vibration of one of its bonds. The IR radiation absorbed allows the bond to vibrate a bit more, that is increase the *amplitude* of vibration, but the vibrational *frequency* will remain the same.

In an **infrared spectrophotometer** (**Fig. 6.2b**) a beam of IR radiation passed through the sample and some radiation is absorbed by the sample, the remaining go through. Another beam of IR radiation pass through the cell with blank (no sample, no absorption) and all light go through. The detector in the instrument record and compare the radiation transmitted through the sample with that transmitted in the absence of the sample. Any frequencies absorbed by the sample will be apparent by the difference. The computer plots the result as a graph showing transmittance vs frequency (in format of wavenumber that will be explained next).

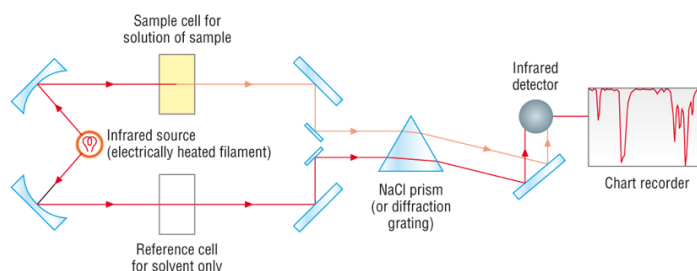

Fig. 6.2b Diagram of the IR Spectrometer

This page titled **6.2: Infrared (IR) Spectroscopy Theory** is shared under a **CC BY-NC-SA 4.0** license and was authored, remixed, and/or curated by **Xin Liu (Kwantlen Polytechnic University)**.

6.3: IR Spectrum and Characteristic Absorption Bands

35

6.3 IR Spectrum and Characteristic Absorption Bands

Xin Liu

With the basic understanding of the IR theory, we will take a look at the actual output from IR spectroscopy experiments, and learn how to get structural information from IR spectrum. Below is the IR spectrum for 2-hexanone.

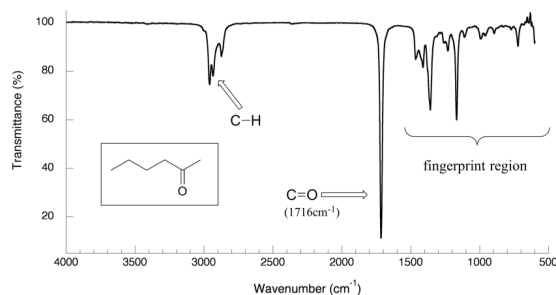

Figure 6.3a IR Spectrum of 2-hexanone

Notes for interpreting IR spectra:

- The vertical axis is ‘% transmittance’, which tells how strongly light was absorbed at each frequency. The solid line traces the values of % transmittance for every wavelength passed through the sample. At the high end of the axis, 100% transmittance means no absorption occurred at that frequency. Lower values of % transmittance mean that some of the energy is absorbed by the compound, and gives the downward spikes. The spikes are called **absorption bands** in an IR spectrum. A molecule have a variety of covalent bonds, and each bond have different vibration modes, so the IR spectrum of a compound usually show multiple absorption bands.
- The horizontal axis indicates the position of an absorption band. But instead of using frequency to show the absorbed radiation, **wavenumbers** ($\bar{\nu}$, in unit of cm^{-1}) are used as a conventional way in IR spectra. The wavenumber is defined as the reciprocal of wavelength (**Formula 6.3**), and the wavenumbers of infrared radiation are normally in the range of 4000 cm^{-1} to 600 cm^{-1} (approximate corresponds the wavelength range of $2.5 \mu\text{m}$ to $17 \mu\text{m}$ of IR radiation).

$$\begin{aligned} \text{wavenumber } (\bar{\nu}, \text{cm}^{-1}) &= 1 / \lambda \text{ (with } \lambda \text{ in cm)} \\ &= 1 / 100\lambda \text{ (with } \lambda \text{ in m)} \\ &= 10^4 / \lambda \text{ (with } \lambda \text{ in nm)} \end{aligned}$$

Formula 6.3

Formula 6.3 Wavenumber

Please note the direction of the horizontal axis (wavenumber) in IR spectra decrease from left to right. The larger wavenumbers (shorter wavelengths) are associated with higher frequencies and higher energy.

The power of infrared spectroscopy arises from the observation that **the covalent bonds characterizing different functional groups have different characteristic absorption frequencies** (in wavenumber, **Table 6.1**). The technique is therefore very useful as a means of identifying which functional groups are present in a molecule of interest.

For example, the most characteristics absorption band in the spectrum of 2-hexanone (**Figure 6.3a**) is that from the stretching vibration of carbonyl double bond C=O, at 1716 cm^{-1} . It is a very strong band comparing to the others on the spectrum. **A strong absorbance band in the $1650\text{-}1750 \text{ cm}^{-1}$ region indicate that a carbonyl group (C=O) is present.** Within that range, carboxylic acids, esters, ketones and aldehydes tend to absorb in the higher wavenumber/frequency end ($1700\text{-}1750 \text{ cm}^{-1}$), while conjugated unsaturated ketones and amides tend to absorb on the lower wavenumber/frequency end ($1650\text{-}1700 \text{ cm}^{-1}$).

Stretching Vibrations

Generally, stretching vibrations the stretching vibrations require more energy and show absorption bands in the higher wavenumber/frequency region. The characteristics stretching vibration bands associated with the bonds in some common functional groups are summarized in **Table 6.1**.

Formula	Bond	Characteristic IR Frequency range (cm ⁻¹)
alcohol	O-H stretching	3200 – 3600 (broad)

carbonyl

1650 – 1750 (strong) aldehyde	C=O stretching
~ 2800 and ~ 2700 (medium) carboxylic acid	C-H stretching
1700 – 1725 (strong)	C=O stretching
2500 – 3300 (broad) alkene	O-H stretching
1620 – 1680 (weak)	C=C stretching
3020 – 3080 benzene	vinyl =C-H stretching
~ 1600 and 1500 – 1430 (strong to weak) alkyne	C=C stretching
2100 – 2250 (weak)	C≡C stretching
3250 – 3350 alkane	terminal ≡C-H stretching
2850-2950 amine	C-H stretching
3300-3500 (medium)	N-H stretching

Table 6.1 Characteristic IR Frequencies of Stretching Vibrations

The information in **Table 6.1** can be summarized in the diagram that is easier to be identified (**Figure 6.3b**), in which the IR spectrum is divided in several regions, with the characteristic band of certain groups labelled.

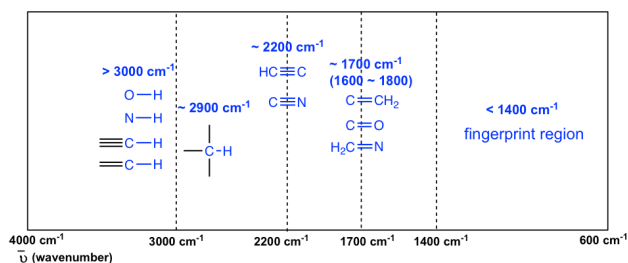

Figure 6.3b Approximate IR Absorption Range

The absorption bands in IR spectra have different intensity, that can usually be referred to as strong (s), medium (m), weak (w), broad and sharp. The intensity of a absorption band depends on the polarity of the bond, the bond with higher polarity will show

more intense absorption band. The intensity also depends on the number of bonds responsible for the absorption, the absorption band with more bonds involved has higher intensity.

The characteristic IR frequencies of stretching vibrations in **Table 6.1** and **Figure 6.3b** provide very useful information to identify the presence of certain functional group, that can be generally summarized as:

The polar **O-H bond** (in alcohol and carboxylic acid) usually shows strong and broad absorption bands that are easy to be identified. The broad shape of the absorption band results from the hydrogen bonding of the OH groups between molecules. The OH bond of alcohol group usually has absorption in the range of $3200\text{-}3600\text{ cm}^{-1}$, while the OH bond of carboxylic acid group occurs at about $2500\text{-}3300\text{ cm}^{-1}$ (**Figure 6.4a** and **Figure 6.4c**).

The polarity of **N-H bond** (in amine and amide) is weaker than OH bond, so the absorption band of N-H is not as intense, nor that broad as O-H, and the position is in $3300\text{-}3500\text{ cm}^{-1}$ region.

The **C-H bond** stretching of all hydrocarbons occur in the range of $2800\text{-}3300\text{ cm}^{-1}$, and the exact location can be used to distinguish between alkane, alkene and alkyne. Specifically:

- $\equiv\text{C-H}$ (sp C-H) bond of terminal alkyne give absorption at about 3300 cm^{-1}
- $=\text{C-H}$ ($\text{sp}^2\text{ C-H}$) bond of alkene give absorption at about $3000\text{-}3100\text{ cm}^{-1}$
- $-\text{C-H}$ ($\text{sp}^3\text{ C-H}$) bond of alkane give absorption at about $\sim 2900\text{ cm}^{-1}$ (see the example of IR spectrum of 2-hexanone in **Figure 6.3a**, the C-H absorption band at about 2900 cm^{-1})

A special note should be taken for the C-H bond stretching of an aldehyde group that shows two absorption bands, one at $\sim 2800\text{ cm}^{-1}$ and the other at $\sim 2700\text{ cm}^{-1}$. It is therefore relative easy to identify the aldehyde group (together with the C=O stretching at about 1700 cm^{-1}) since essentially no other absorptions occur at these wavenumbers (see the example of IR spectrum of butanal in **Figure 6.4d**).

The stretching vibration of triple bonds **$\text{C}\equiv\text{C}$** and **$\text{C}\equiv\text{N}$** have absorption bands of about $2100\text{-}2200\text{ cm}^{-1}$. The band intensity are in medium to weak level. The alkynes can generally be identified with the characteristic weak but sharp IR absorbance bands in the range of $2100\text{-}2250\text{ cm}^{-1}$ due to stretching of the $\text{C}\equiv\text{C}$ triple bond, and terminal alkynes can be identified by their absorbance at about 3300 cm^{-1} , due to stretching of sp C-H .

As mentioned earlier, the **C=O** stretching has strong absorption band in the $1650\text{-}1750\text{ cm}^{-1}$ region. Other double bonds like **C=C** and **C=N** have absorptions in bit lower frequency regions of about $1550\text{-}1650\text{ cm}^{-1}$. The C=C stretching of an alkene only shows one band at $\sim 1600\text{ cm}^{-1}$ (**Figure 6.4b**), while a benzene ring is indicated by two sharp absorption bands, one at $\sim 1600\text{ cm}^{-1}$ and one at $1500\text{-}1430\text{ cm}^{-1}$ (see the example of IR spectrum of ethyl benzene in **Figure 6.4e**).

You will notice in **Figure 6.3a** and **6.3b** that a region with the lower frequency $400\text{-}1400\text{ cm}^{-1}$ in the IR spectrum is called the **fingerprint region**. Kind of like a human fingerprint, the pattern of absorbance bands in the fingerprint region is characteristic of the compound as a whole. Even if two different molecules have the same functional groups, their IR spectra will not be identical and such difference will be reflected in the bands in the fingerprint region. Therefore the IR from an unknown sample can be compared to a database of IR spectra of known standards in order to confirm the identification of the unknown sample.

This page titled [6.3: IR Spectrum and Characteristic Absorption Bands](#) is shared under a [CC BY-NC-SA 4.0](#) license and was authored, remixed, and/or curated by [Xin Liu \(Kwantlen Polytechnic University\)](#).

6.4: IR Spectrum Interpretation Practice

Now, let's take a look at the more IR spectrum for examples. It is very important to keep in mind that generally we do not try to identify all the absorption bands in an IR spectrum. Instead, we will **look at the characteristic absorption band to confirm the presence or absence of a functional group**. An IR spectrum usually does not provide enough information for us to figure out the complete structure of a molecule, and other instrumental methods have to be applied in conjunction with, such as NMR that we will learn in later sections, that is a more powerful analytical method to give more specific information about molecular structures.

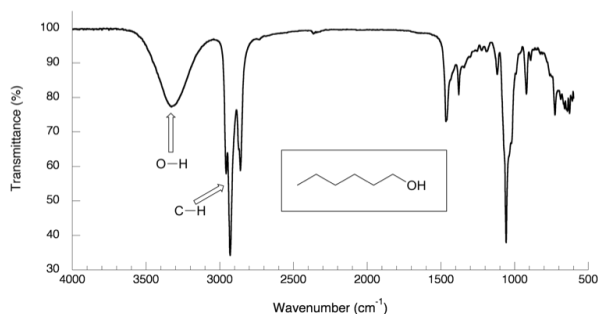

Figure 6.4a IR Spectrum of 1-hexanol

In the IR spectrum of 1-hexanol, there are sp^3 C-H stretching bands of alkane at about $2800\text{--}3000\text{ cm}^{-1}$ as expected. Other than that, there is a very broad peak centered at about 3400 cm^{-1} , that is the characteristic band of the O-H stretching mode of alcohols.

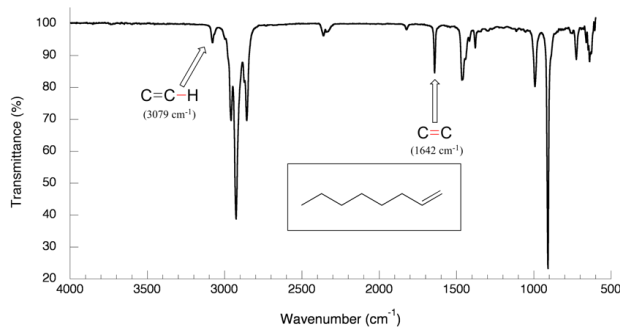

Figure 6.4b IR Spectrum of 1-octene

The spectrum for 1-octene shows two bands that are characteristic of alkenes: the one at 1642 cm^{-1} is due to stretching of the carbon-carbon double bond, and the one at 3079 cm^{-1} is due to stretching of the σ bond between the sp^2 -hybridized alkene carbons and their attached hydrogens.

The following IR spectrum are taken from [Spectral Database for Organic Compounds](#), the free organic compounds spectral database. The key bands for each compound are labelled on the spectra.

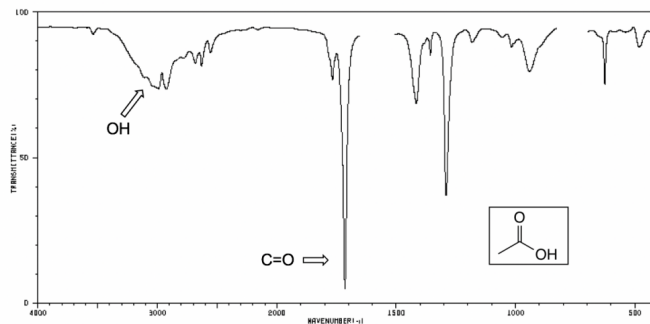

Figure 6.4c IR Spectrum of acetic acid

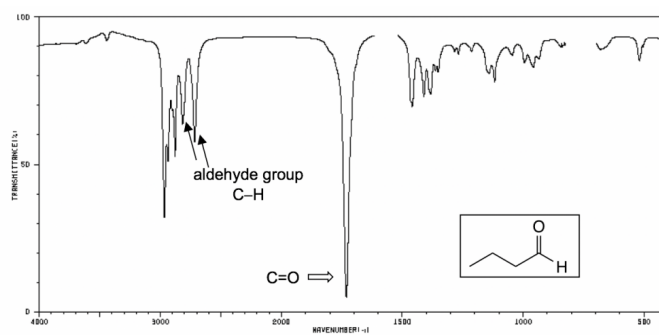

Figure 6.4d IR Spectrum of butanal

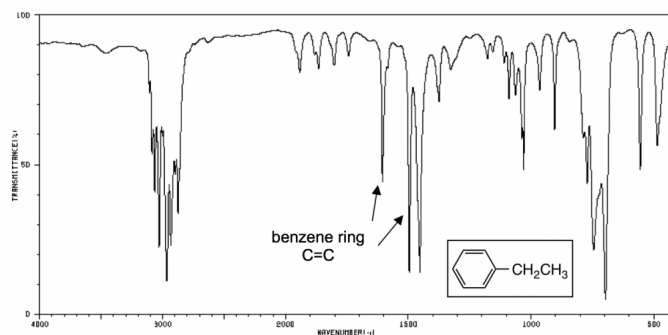

Figure 6.4e IR Spectrum of ethyl benzene

This page titled [6.4: IR Spectrum Interpretation Practice](#) is shared under a [CC BY-NC-SA 4.0](#) license and was authored, remixed, and/or curated by [Xin Liu \(Kwantlen Polytechnic University\)](#).

6.5: NMR Theory and Experiment

37

Although the other techniques provide valuable information about a molecule, they do not tell us what about the overall molecular structure, or the framework about C-C and C-H bonds. Nuclear magnetic resonance (NMR) spectroscopy is an immensely powerful analytical technique that provides such information. NMR works by the same principles as an Magnetic Resonance Imaging (MRI) scanner in a hospital. MRI is a scanning technique to detect the hidden medical problems without causing any harm of pain to the patient. While doctors use MRI peer inside the human body, we will see how NMR allows organic chemists to piece together, atom by atom and bond by bond, the structure of an organic molecule.

NMR-active Nuclei

The basis for NMR is the phenomenon that some atomic nuclei spin about their axes and as a result generate their own magnetic field, or **magnetic moment**, therefore these nuclei are called **NMR-active**. Not all nuclei have a magnetic moment though, only those nuclei with an odd number of proton and/or neutron have. Fortunately nuclei that are important for organic compounds, such as the ^1H isotope of hydrogen, the ^{13}C isotope of carbon, the ^{14}N isotope of nitrogen, ^{19}F and the ^{31}P are all NMR-active and therefore can be observed by NMR. Other nuclei, such as the common ^{12}C isotopes of carbon and ^{16}O isotope of oxygen, do not have magnetic moments, and cannot be directly observed by NMR.

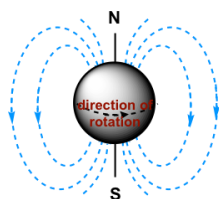

the magnetic field associated with a spinning nucleus

Figure 6.5a The magnetic field

In practice, the ^1H and ^{13}C nuclei are most commonly observed by NMR spectroscopy, and we will focus on these techniques in this chapter, beginning with ^1H NMR. ^1H NMR is usually called proton NMR, because the nucleus of ^1H atom is actually a single proton. The name of 'proton' and 'hydrogen' will be used interchangeably in this chapter for ^1H NMR purpose.

Spin State and Magnetic Resonance

We will take proton, the nucleus of ^1H atom, as an example for the discussions here.

When a sample of an organic compound is sitting in a flask on a laboratory bench, the magnetic moments of all of its protons are oriented randomly. However, when the same sample is placed within the field of a strong magnet in an NMR instrument (this field is referred to as the **applied external magnetic field, B_0** , in NMR), each proton will assume one of two possible orientations with respect to the external magnetic field. These two orientations corresponds to the two spin states that can be labelled as α and β . In the α spin state, the proton's magnetic moment is aligned *with* the direction of external magnetic field B_0 , while in the β spin state it is aligned *opposed* to the direction of B_0 (**Fig. 6.5b**).

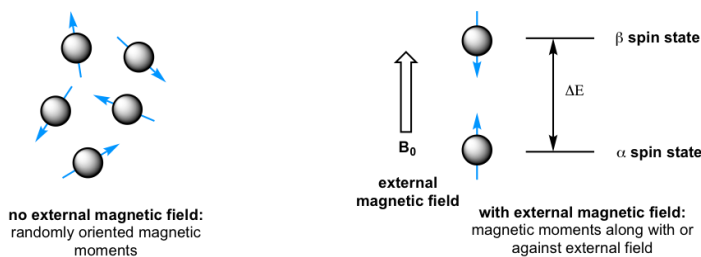

Figure 6.5b Orientations of magnetic moments of protons without and with external magnetic field

The α spin state is slightly lower in energy than the β state, and the energy gap between them, ΔE , depends upon the strength of B_0 : a stronger applied external magnetic field results in a larger ΔE . For a large population of organic molecules in an external

magnetic field, slightly *more* than half of the protons will occupy the lower energy α spin state, while slightly *less* than half will occupy the higher energy β spin state. It is this population difference between the two spin states that is exploited by NMR, and the difference increases with the strength of the applied magnetic field B_0 .

Energy is required to excite the proton from the lower energy state (α spin state) to the higher energy state (β spin state). In an NMR spectrometer the energy is supplied by electromagnetic radiation in the radio frequency (RF) region. When a proton in an external magnetic field is exposed to RF radiation with the energy that matches the energy gap ΔE , the energy of the RF is absorbed and the proton will flip its magnetic moment from the lower energy state (α spin state) to the higher energy state (β spin state), the nuclei are said to be in **resonance** with the electromagnetic radiation.

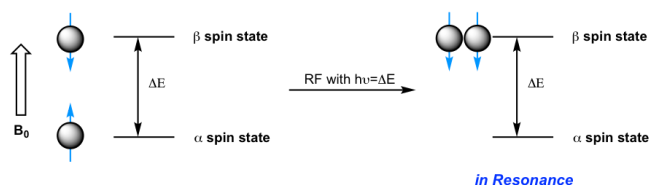

Figure 6.5c Resonance

The frequency of radiation absorbed by a proton (or any other nucleus) during a spin transition in the NMR experiment is called its **resonance frequency**, ν . As a result, the resonance frequency also depends on B_0 , the larger B_0 the higher resonance frequency, and the relationship fits to the specific formula: (**Formula 6.4** is for your information purpose only)

$$\nu = \frac{\gamma B_0}{2\pi}$$

Formula 6.4

γ is the magnetogyric (or gyromagnetic) ratio, different nucleus has different value of γ . For a proton, the γ value is $26.753 \text{ rad} \cdot \text{s}^{-1} \cdot \text{tesla}^{-1}$.

Calculations indicate that if external magnetic field $B_0 \cong 1.41$ Tesla, the energy difference corresponds to RF with the frequency of 60×10^6 Hz (60 MHz) for proton; when $B_0 \cong 7.04$ Tesla, the corresponding RF frequency is 300×10^6 Hz (300 MHz) for proton. This frequency is the most important parameter for a NMR spectrometer (the instrument that run NMR experiments), the higher the frequency, the more sensitive the instrument and the higher resolution the resulting NMR spectrum is.

The NMR Experiment

In this book we will just explain how the NMR experiment and NMR spectrometer work in a simplified way (again with proton as an example), the full version is out of the scope of this course.

When a sample of compound is placed in the strong applied external magnetic field B_0 of the instrument, the protons begin to spin with one of the two spin states. Initially, slightly more than half of the protons have the magnetic moments in α spin states (aligned with B_0), and slightly less than half are in β spin states (aligned against B_0). Then, the sample is exposed to a range of radio frequencies. Out of all of the frequencies which hit the sample, only the frequencies that matches the resonance frequency of the protons are absorbed, causing those protons which are aligned with B_0 to 'spin flip' so that they align themselves against B_0 . When the 'flipped' protons flip back down to their ground state, they emit energy, again in the form of radio-frequency radiation. The NMR instrument detects and records the frequency and intensity of this radiation by making use of a mathematical technique known as a Fourier transform (FT). Fourier Transform convert the signal from a time *versus* amplitude signals to a frequency *versus* amplitude signals, that is what we observe in a NMR spectrum.



Figure 6.5d Simplified diagrams to illustrate NMR experiment

Most modern FT-NMR spectrometers use superconducting magnets that have very high magnetic fields, therefore operate with high resonance frequency from 100 MHz to 800 MHz. Superconducting magnets operate in a bath of liquid nitrogen or liquid helium at very low temperature.



FT-NMR with superconducting magnet

A model of bench top NMR: NMRReady-60

Figure 6.5e FT-NMR with superconducting magnet and a model of bench top NMR: NMRReady-60

Despite the powerfulness and high resolution of the high frequency NMR spectrometers, it is very costly for purchase and maintenance of the instrument. For teaching purpose, the bench top NMR are becoming more and more popular recently. The frequency of bench top NMR are usually in the range of 60-90 MHz, however, they can provide spectra with good resolution for lots basic organic structures that are used for undergraduate organic chemistry class. With the low-cost bench top NMR available, students have chance to gain hand-on NMR experiences in sample preparation, instrument operation and spectrum processing.

Shielding and Deshielding

If all hydrogen atoms (and protons) in organic molecules had the same resonance frequency, then they all show the same signal, NMR spectroscopy would not be that useful for chemists. Fortunately, however, resonance frequencies are different for different protons in a molecule. Specifically, the resonance frequency varies according to the electronic environment that a given proton inhabits.

For hydrogen atoms in any bonds, such as C-H, O-H etc, the external magnetic field \mathbf{B}_0 causes the s electrons to circulate in a way that generate an induced **local magnetic field** ($\mathbf{B}_{\text{local}}$) at the proton, and the direction of the local field $\mathbf{B}_{\text{local}}$ is opposite to the external field \mathbf{B}_0 . The proton thus experiences a net magnetic field, which is called \mathbf{B}_{eff} , that is smaller than the applied magnetic field:

$$\mathbf{B}_{\text{eff}} = \mathbf{B}_0 - \mathbf{B}_{\text{local}}$$

As a result, the proton responds to a lower frequency (resonance frequency is proportional to the magnetic field as mentioned early). This $\mathbf{B}_{\text{local}}$, to a small but significant degree, shield the proton from experiencing the full force of \mathbf{B}_0 , so this effect is called **shielding effect**. Different hydrogen atoms in organic structures are in different electronic environment, have different selectron density, therefore have different $\mathbf{B}_{\text{local}}$ and different \mathbf{B}_{eff} as well. That is why different hydrogens (and protons) are in different resonance frequency and show different signals in the spectrum.

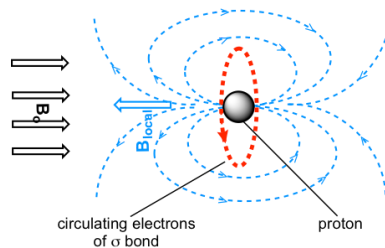

Shielding effect: $\mathbf{B}_{\text{local}}$ generated by the circulation electrons of α bond shield the proton from the external magnetic field \mathbf{B}_0 .

Figure 6.5f Shielding effect

For hydrogen atoms close to electronegative groups, electronegative groups withdraw electron density from nearby atoms, so diminishing the shielding of the protons by circulating electrons. The hydrogen atoms near an electronegative groups are said to be **deshielded** from the external magnetic field, and have a higher resonance frequency than those shielded protons. As the electronegativity of the substituent increase, so does the extent of the deshielding effect (and so the chemical shift, see **section 6.6.2** for more discussions about chemical shift) as shown in the examples below.

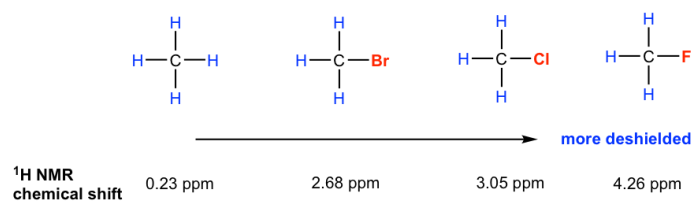

H atoms get **more deshielded** with electronegativity of substituent increase

Figure 6.5g H atoms get more deshielded with electronegativity of substituent increase

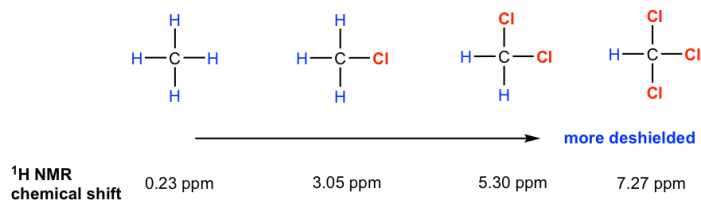

H atoms get **more deshielded** with more electronegative substituents involved

Figure 6.5h H atoms get more deshielded with more electronegativity substituents involved

This page titled [6.5: NMR Theory and Experiment](#) is shared under a [CC BY-NC-SA 4.0](#) license and was authored, remixed, and/or curated by [Xin Liu](#) (Kwantlen Polytechnic University) .

6.6: ^1H NMR Spectra and Interpretation (Part I)

Understanding the basics of NMR theory gets us ready to move on to the most important and practical part in this section, that is how to understand the ^1H NMR spectrum and elucidate the structure of a compound from ^1H NMR spectrum information. Let's first take a look at an actual ^1H NMR spectrum.

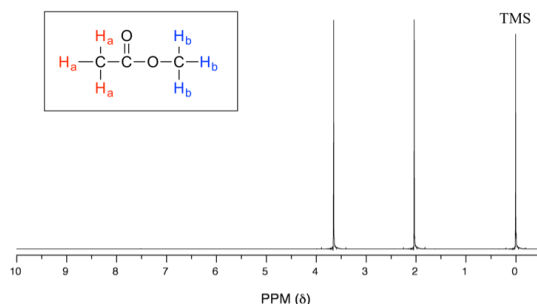

Fig. 6.6a The ^1H NMR spectrum of methyl acetate

Generally, the information about the structure of molecule can be obtained from four aspects of a typical ^1H NMR spectrum:

- Chemical equivalent and non-equivalent protons (total number of signals)
- Chemical shift
- Integration
- Signal splitting

6.6.1 Chemical Equivalent and Non-Equivalent Protons

In the above ^1H NMR spectrum of methyl acetate (**Fig. 6.6a**), we can see that there are three signals. The peak at the far right is for the standard reference compound tetramethylsilane (TMS, more discussions in chemical shift section **6.6.2**), not for the compound. So the compound methyl acetate shows two signals in ^1H NMR spectrum. Why only two signals for a compound containing total six hydrogens?

This is because of chemical equivalence. The total six hydrogens can be divided to two groups, the three H_a protons in the methyl group that bonded with $\text{C}=\text{O}$ are all in the same chemical environment, therefore they are chemical equivalent. All chemical equivalent hydrogens have the same resonance frequency with applied to an external magnetic field, so show only one signal in ^1H NMR spectrum. The three H_b protons in the methyl group bonded with O atom are chemical equivalent as well and show the other signal. That is why there are total two signals for compound methyl acetate.

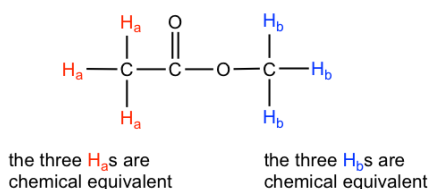

The ability to recognize chemical equivalent and non-equivalent protons in a molecule is very important in understanding NMR spectrum. For the compound with structure given, we should be able to predict how many signals are there in ^1H NMR spectrum. On the other side, if the ^1H NMR spectrum is available for an unknown compound, counting the number of signals in the spectrum tells us the number of different sets of protons in the molecule, and that is the very important information to determine the structure of the compound.

Here we will go through several examples for the first situation, that is to predict the number of signals in ^1H NMR spectrum with the structure of a compound given. To do that, we need to count how many distinct proton sets are included in the molecule.

For each of the following molecule, the chemically equivalent protons are labelled in the same *color* to facilitate the understanding.

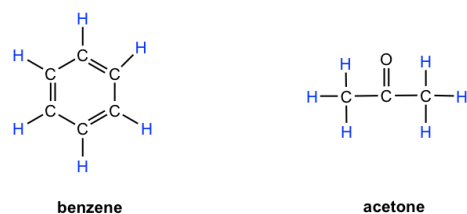

- Benzene: all six protons are chemical equivalent (have the same bonding and in the same chemical environment) to each other and have the same resonance frequency in an ^1H NMR experiment, therefore show only **one** signal.
- Acetone: both methyl groups (two CH_3) bonded with $\text{C}=\text{O}$ bond, so they are in the same chemical environment, and as a result all the six protons are chemical equivalent that show only **one** signal.

Notes: As you probably already realized, chemical equivalence or non-equivalence in NMR is closely related to *symmetry*. The protons that are symmetric to each other by a certain plane of symmetry are chemical equivalent.

The molecules in the next figure contains more sets of chemically equivalent protons.

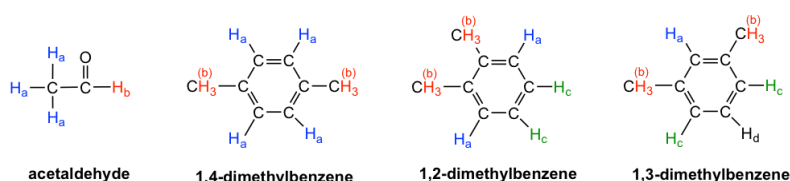

- Acetaldehyde: The three H_a protons in the methyl group are chemical equivalent, and they all bonded to an sp^3 -hybridized carbon; but they are different to the H_b proton that is bonded to an sp^2 -hybridized carbonyl carbon. **Two** signals total in ^1H NMR spectrum.
- 1,4-dimethylbenzene: all four aromatic protons in are chemically equivalent because of the symmetry. The two methyl groups are equivalent to each other as well. **Two** signals total in ^1H NMR spectrum.
- 1,2-dimethylbenzene: both H_a protons are adjacent to a methyl substituent, while both H_c protons are two carbons away. So the four aromatic protons are divided to *two* sets. Both methyl groups are in the same bonding and symmetric to each other, they are equivalent. **Three** signals total in ^1H NMR spectrum.
- 1,3-dimethylbenzene: H_b is situated between two methyl groups, the two H_c protons are one carbon away from a methyl group, and H_d is two carbons away from a methyl group. Therefore, the four aromatic protons can be divided to *three* sets. The two methyl groups are equivalent. **Four** signals total in ^1H NMR spectrum.

Exercises 6.1

How many ^1H NMR signals would you predict for each of the following molecules?

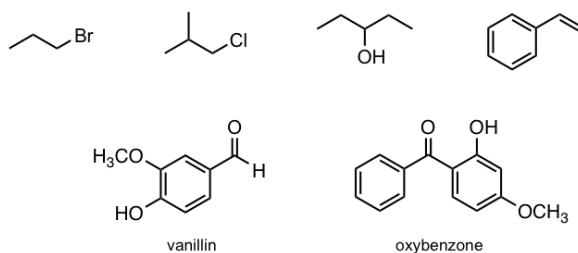

Answers to Practice Questions Chapter 6

6.6.2 Chemical Shift

As seen in the ^1H NMR spectrum of methyl acetate (**Fig. 6.6a**), the x -axis units of NMR spectrum are in ppm (not in Hz as we would expect for frequency), and the two signals stand at different position along the x -axis. Let's explain how that works and what information can be obtained.

The position of a signal along the x-axis of an NMR spectra is called **chemical shift**, or δ , of the signal. Chemical shift is determined by the structural/electronic environment of the nuclei producing that signal. Protons in different chemical environments (non-equivalent) show signals at different chemical shift. The *direction* of chemical shift scale in x-axis is opposite to what we are familiar with, that is the smaller value is at right-hand side, and the larger value is at the left-hand side (**Fig. 6.6b**).

- Smaller chemical shift (δ) values correspond with lower resonance frequency;
- Larger chemical shift (δ) values correspond with higher resonance frequency.

By **convention**, the right-hand side of an NMR spectrum with smaller chemical shift values is called **upfield**, and the left-hand direction is called **downfield** (**Fig. 6.6b**).

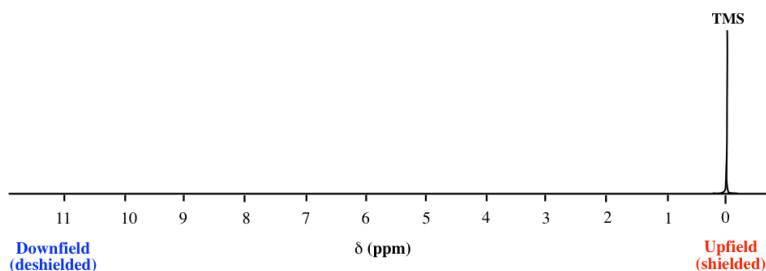

Figure 6.6b The chemical shift scale in ^1H NMR spectra

For protons that are **shielded**, because of the Bloch caused by circulating electrons, the magnetic field experienced by the proton, B_{eff} , is smaller than applied external field, B_0 , so the protons resonance at lower frequency and have smaller chemical shift values.

- Shielded protons have lower resonance frequency, and smaller chemical shift (δ) values;
- Deshielded protons have higher resonance frequency, and larger chemical shift (δ) values.

In ^1H NMR spectrum, the absorption of the protons of **TMS** (tetramethylsilane) is defined as “zero” on the chemical shift (δ) scale, and the absorption of other protons are reported as relative shift compared with that of TMS.

TMS was chosen as a reference compound and defined as “zero” for several reasons. Since silicon is less electronegative than carbon, the hydrogens of TMS are in high electron-density environment, therefore are highly shielded with very low resonance frequency and rarely interfere with the signals of other compounds. Also there are twelve equivalent hydrogens in TMS that show a *single* signal, so the signal is rather strong even with very little amount of TMS. TMS is also quite inert and easy to be removed with the boiling point of 27°C . A small amount of TMS was used to be added in the sample as an internal standard for NMR measurement, and removed by evaporation afterwards. However, for contemporary NMR spectrometer (including the bench top NMR), it is no longer necessary to actually add TMS since the computer can calibrate the chemical shift electronically based on resonance frequencies of the solvent used.

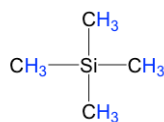

tetramethylsilane (TMS)

The unit of chemical shift (δ) is **ppm**. The ‘ppm’ label stands for ‘parts per million’. The chemical shift relative to TMS in ppm is defined as the formula below.

$$\delta = \frac{\text{distance of peak from TMS in Hz}}{\text{spectrometer frequency in MHz}}$$

The reason for using a relative value of chemical shift in ppm, rather than the actual resonance frequency in Hz is that every NMR instrument will have a different magnetic field strength, so the actual value of resonance frequencies expressed in Hz will be different on different instruments – remember that ΔE for the magnetic transition of a nucleus depends upon the strength of the externally applied magnetic field B_0 . However, the chemical shift expressed in ppm will always be the same whether measured with an instrument operating at 400 MHz or 60 MHz. In the ^1H NMR of methyl acetate, the two signals are at 2.0 and 3.6 ppm represents the two sets of protons in methyl acetate have resonance frequencies about 2.0 and 3.6 parts per million higher than the resonance frequency of the TMS protons. If, for example, the spectrum is measured by the 400 MHz NMR spectrometer, then the chemical shift in Hz will be 800 Hz and 1440 Hz respectively.

Most protons in organic compounds have chemical shift values between 0 and 12 ppm relative to TMS, although values below 0 ppm and above 12 ppm are occasionally observed. The chemical shift value of hydrogens in certain structural environment, or common organic functional groups, are listed in chart (**Fig. 6.6c**) and table (**Table 6.2**) below.

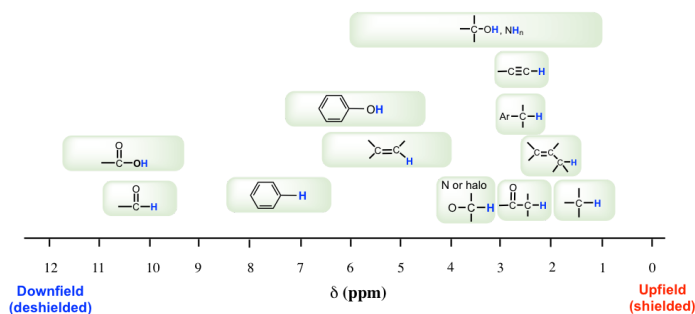

Figure 6.6c Chart of Approximate proton Chemical Shifts

Type of Proton	Chemical Shift (ppm)	Type of Proton	Chemical Shift (ppm)
$R-CH_3$	0.9 – 1.2	$X-CH_2R$ (X: Cl, Br, I)	3.1 – 3.8
$R-CH_2$	1.2 – 1.5	$R-OH$	variable, 1 – 5
$R-CH$	1.4 – 1.9	$R-NH_2$	variable, 1 – 5
$R-C=C-CH_2R_2$	1.5 – 2.5	$R-C=C-H$	4.5 – 6.0
$R-C(=O)CH_3$	2.0 – 2.6	$Ar-H$	6.0 – 8.5
$Ar-CH_3$	2.2 – 2.5	$R-C(=O)H$	9.5 – 10.5
$R-C\equiv C-H$	2.5 – 3.0	$R-C(=O)OH$	10 – 13
$(H)R-O-CH_3$	3.3 – 4.0		

Table 6.2: Approximate Proton Chemical Shifts of Common Functional Groups

The importance of chemical shift information is that it gives critical clues about *molecular structures*. Several highlights here:

- Usually the hydrogens in C-H bond, without any other functional groups nearby, are in the range of 1-2 ppm;
- For hydrogen in C-H bond beside double bond, like C=C or C=O bond, the signal goes downfield to 2-2.5 ppm;
- With electronegative atoms connected on the carbon, like O-C-H, the hydrogens get deshielded and chemical shift move further downfield to 3-4 ppm;
- The hydrogens bonded directly to double bond carbon have the chemical shift at around 4.5-6 ppm;
- The aromatic hydrogens (H on benzene ring) show chemical shift around 7 ppm;
- The chemical shift of hydrogens in OH (alcohol) or NH (amine) group vary in a rather large range, from 1-5 ppm;
- The hydrogen in aldehyde (-CHO) and carboxylic acid (COOH) group has the chemical shift rather downfield at about 9-10 ppm and 10-12 ppm respectively.

When referring to the chemical shift table (or chart) for a certain compound, it is useful to keep in mind that the exact value may vary a bit to the given range, sometimes the difference up to 0.5 ppm unit may happen depends on the specific structure and the solvent used.

With chemical shift information available, we can now assign the signals in the 1H NMR spectrum of methyl acetate. According to **Fig. 6.6c**, the protons in CH_3 group beside $C=O$ bond are supposed to be in the range of 2-3 ppm, and protons in CH_3 group connected with O directly have δ value of about 3-4 ppm. So the 2.0 ppm signal is for the H_a group and 3.6 ppm signal is for H_b group.

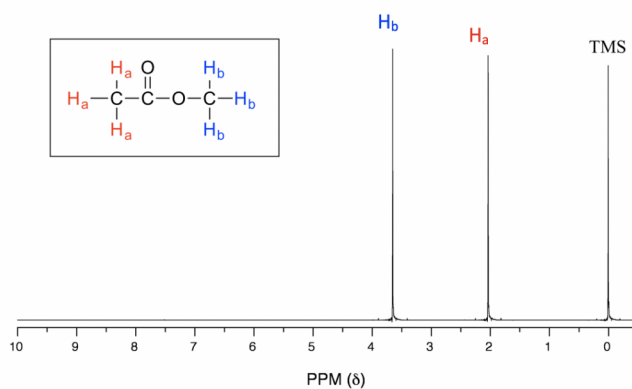
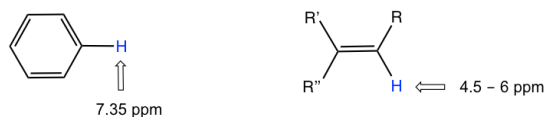

Fig. 6.6d The ^1H NMR spectrum of methyl acetate with signals assignment

Chemical Shift of Protons Near π Electrons — Anisotropy Effect

The chemical shift values of aromatic protons and vinylic protons (those directly bonded to an alkene carbon) resonate much further downfield (higher frequency, higher chemical shift) than can be accounted for simply by the deshielding effect of nearby electronegative atoms. These chemical shifts result from the anisotropy effect.



Let's investigate the aromatic protons first. In benzene ring (and many other aromatic structures), the total six π electrons form delocalized big π bond around the ring (more discussions in Organic II). When the molecule is exposed to the external magnetic field \mathbf{B}_0 , these π electrons begin to circulate in a ring current and generating their own **induced magnetic field** $\mathbf{B}_{\text{induced}}$. Whether shielding or deshielding occurs depends on the *location* of the protons in the induced magnetic field, and this is called **anisotropy** (means "non-uniformity") **effect**. This can be illustrated specifically in the figure below by comparing between point **A** and **B**.

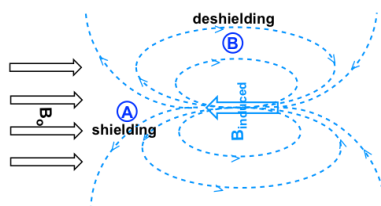

Anisotropy effect of the induced magnetic field $\mathbf{B}_{\text{induced}}$

Figure 6.6e Anisotropy effect of the induced magnetic field $\mathbf{B}_{\text{induced}}$

If a proton is at point **A**, it feels the induced magnetic field pointing to the opposite direction of \mathbf{B}_0 , so the proton experiences **shielding** effect. For the proton at point **B**, however, it feels the induced magnetic field to the same direction as \mathbf{B}_0 , so the proton experiences **deshielding** effect.

The protons on benzene ring are at the position equivalent of 'point **B**', that means that the induced current in this region of space is oriented in the *same* direction as \mathbf{B}_0 , so it *adds* to \mathbf{B}_0 and result in a deshielding effect and the benzene protons resonance at a higher frequency and have larger chemical shifts.

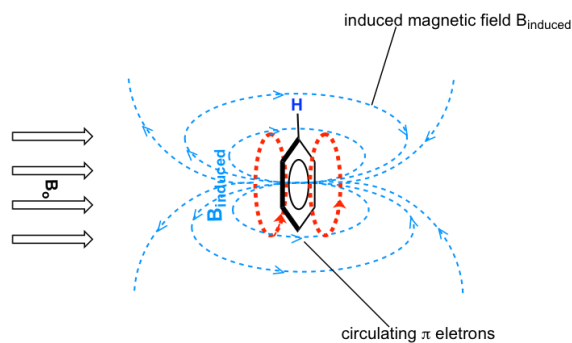

Anisotropy Effect of Benzene ring:
aromatic protons are at the location with **deshielding effect**, where the B_{induced} is in the same direction as the B_0

Figure 6.6f Anisotropy effect of Benzene ring: aromatic protons are at the location with deshielding effect, where the B_{induced} is in the same direction as the B_0

As a result, due to the anisotropy of the induced field generated by the circulating π electrons, the benzene protons are highly deshielded. Their chemical shift is far downfield, in the range of 6.5–8.5 ppm.

Anisotropy is also responsible for the downfield (high frequency) chemical shifts of vinylic protons (4–6.5 ppm) and aldehyde protons (9.5–11 ppm). The π electrons in these groups also circulate in such a way to generate an induced magnetic field that *adds* to external field B_0 in the spots occupied by the protons. Carboxylic acid protons are even further downfield (9.5–12 ppm) due to the combined influence of the electronegative oxygen atom and the nearby π bond.

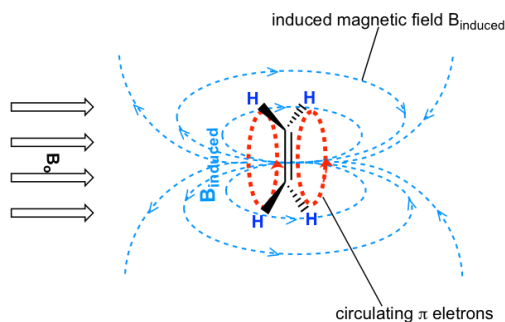

Anisotropy Effect of Alkene:
vinylic protons are at the location with **deshielding effect**, where the B_{induced} is in the same direction as the B_0

Figure 6.6g Anisotropy Effect of Alkene: Vinylic protons are at the location with deshielding effect, where the B_{induced} is in the same direction as the B_0

This page titled [6.6: ¹H NMR Spectra and Interpretation \(Part I\)](#) is shared under a [CC BY-NC-SA 4.0](#) license and was authored, remixed, and/or curated by [Xin Liu \(Kwantlen Polytechnic University\)](#).

6.7: ^1H NMR Spectra and Interpretation (Part II)

6.7.1 Integration of Signal Areas

The computer in the NMR instrument can be instructed to mathematically integrate the area under a signal or group of signals. The **signal integration** process is very useful in ^1H NMR spectrum, because *the area under a signal is proportional to the number of protons to which the signal corresponds*.

The Fig. 6.7a is the ^1H NMR spectrum of 1,4-dimethylbenzene with integration line (blue lines). The integration line generated by the computer is always in curve shape that resemble steps. The integration numbers are also generated by the computer together with the curve, that show the relative area of each signal (the integration numbers in the actual spectra are usually with decimals, whole numbers are shown here for simplicity).

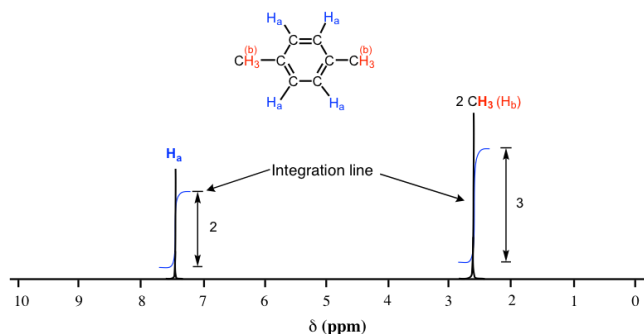

Figure 6.7a The ^1H NMR spectrum of 1,4-dimethylbenzene with integration

As we discussed earlier, the molecule of 1,4-dimethylbenzene has two sets of equivalent protons: the four aromatic (H_a) protons and the six methyl (H_b) protons. The integration of the area under the peak at 2.6 ppm is 1.5 times greater than the area under the peak at 7.4 ppm. **Please note that the integration number show the relative ratio of the number of protons, not the actual number.** The ratio 3 to 2 here matches the ratio of actual number 6 to 4. This integration information, along with the chemical shift knowledge we have learned before allow us to assign the peaks: peak at 7.4 ppm correspond to protons (H_a) on the benzene ring, and the peak at 2.6 ppm correspond to two methyl groups (H_b).

6.7.2 Signal Splitting (Coupling)

In the ^1H NMR spectra that we have seen so far, each set of protons generates a *single* NMR signal. This is not that common for ^1H NMR actually. In fact, the ^1H NMR spectra of most organic molecules contain signals that are ‘split’ into two or more peaks that is called **splitting** (or **coupling**). The spectra with peak splitting may looked more complicated, however, this splitting behavior provides very useful information about the structure of a compound.

Let’s consider the spectrum for 1,1,2-trichloroethane (Fig. 6.7b). In this and in other spectra to follow, the expansions of individual signals are shown so that the signal splitting patterns are recognizable.

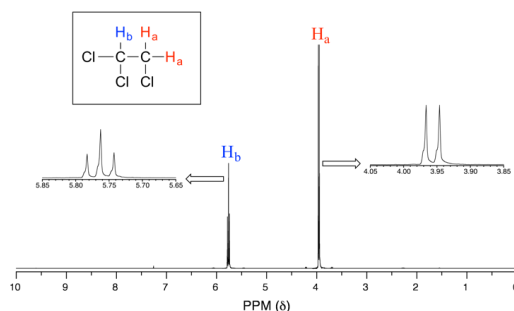
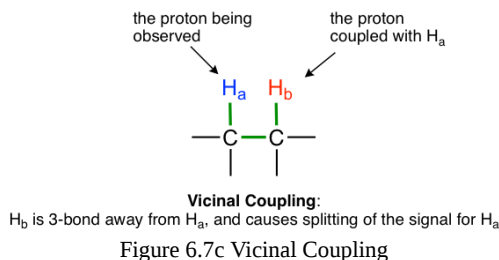

Fig. 6.7b The ^1H NMR spectrum of 1,1,2-trichloroethane with signal splitting

The signal at 3.96 ppm, corresponding to the two H_a protons, is split into two peaks of equal height (and area) – this is referred to as a **doublet**. The H_b signal at 5.76 ppm, on the other hand, is split into three peaks, with the middle peak higher than the two outside peaks and the integration ratio between the three peaks is 1:2:1, such splitting signal is called a **triplet**.

Signal splitting is caused by **spin-spin coupling**, a term that describes the magnetic interactions between non-equivalent hydrogen atoms that are with 2 or 3 bonds of the hydrogens producing the signal. The nearby protons have magnetic moment that can be either against or with the external magnetic field, therefore splits the energy levels of the protons whose signal is being observed, and result in the splitting of the signal into multiple peaks (the terms 'splitting' and 'coupling' are often used interchangeably when discussing NMR).

The most typical coupling we observed in this course is from non-equivalent vicinal hydrogens that are 3 bonds away, that is the hydrogens on adjacent carbons. This is also called **vicinal coupling** or **three-bond coupling**.



A simple rule that applies for predicting the number of peaks (or splitting pattern) expected from coupling and the rule in ¹H NMRs:

$$\text{number of peaks} = n + 1$$

(n is the number of vicinal non-equivalent hydrogens)

We will exam the splitting pattern with different number of n:

- When n=0, the signal is a **singlet**, or has only one peak, as the signals observed in **Fig. 6.6d** and **Fig. 6.7a**.
- When n=1, the signal is a **doublet** with two peaks. The area ratio of the two peaks for a doublet is 1:1. The space between the two peaks is called coupling constant, J_{ab}, measured in Hz.

For the example of compound 1,1,2-trichloromethane, the signal of **H_a** protons fits into this situation. With only one vicinal proton, **H_b**, on the adjacent carbon, the signal of **H_a** show as a doublet.

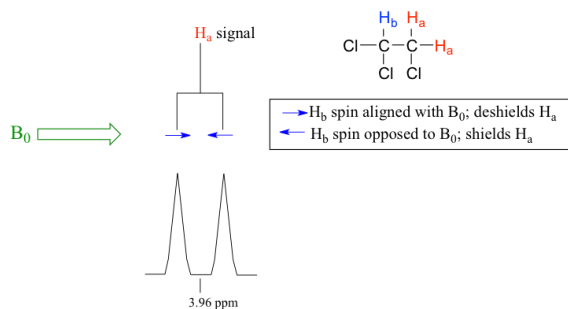

- When n=2, the signal is a **triplet** with three peaks. The three peaks of triplet has the ratio of the area as 1:2:1.

In the same compound 1,1,2-trichloromethane, the signal of **H_b** proton fits into this situation. With two vicinal protons, **2H_a**, on the adjacent carbon, the signal of **H_b** show as a triplet.

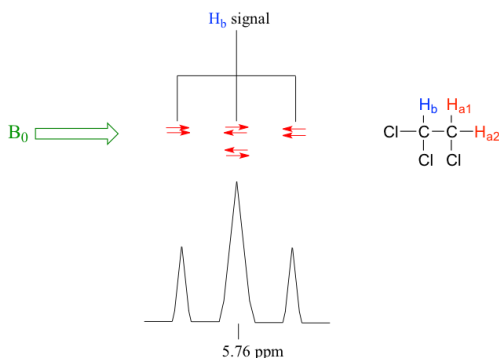

- When $n=3$, the signal is a **quartet**, that means four peaks. The four peaks of quartet has the area ratio of 1:3:3:1.

For the spectrum of ethyl acetate (**Fig. 6.7e**), the signal of H_b is a quartet, because there are three vicinal protons $3H_c$ on the adjacent carbon. Please note that the carbon with H_b connected with oxygen on the other side, and there are no hydrogen atoms on that oxygen atom, so only the coupling with three vicinal protons apply.

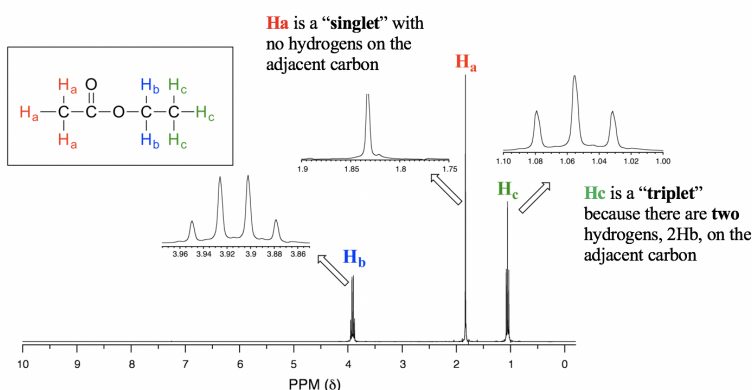

Figure 6.7e The 1H NMR spectrum of ethyl acetate with signals splitting

- When $n \geq 4$, the signal can be called a **multiplet**. Theoretically, with n increase the signal split into more peaks and the total number of peaks is " $n+1$ ". However, the small peaks on the sides may or may not be able to be observed since they might be merged into noise. The signal with more than four peaks are generally called as a multiplet, and it is not that critical to tell exactly how many peaks involved in a multiplet.

Extra notes about signal splitting:

- Splitting (coupling) **only** occurs between **nonequivalent** protons. For equivalent protons, there is no coupling. In the spectrum of succinic acid (**Fig. 6.7f**) for example, the protons on the two middle carbons are equivalent (H_a), so there is no coupling between them and they show a singlet.

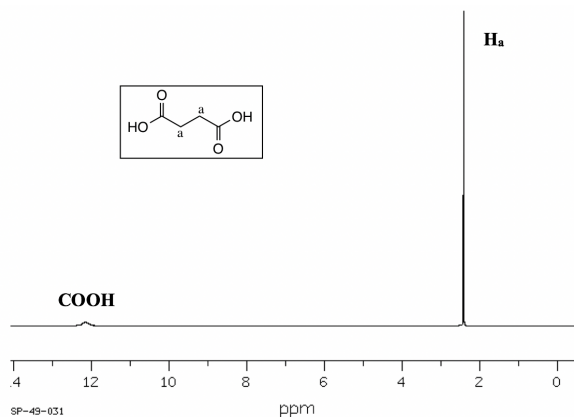

Figure 6.7f 1H NMR spectrum of succinic acid

- Protons in OH or NH generally do not couple with vicinal hydrogens. OH and NH protons are acidic enough to rapidly exchange between different molecules, so the neighboring protons never actually 'feels' their influence. See the specific example of 1-heptanol spectrum in **Fig. 6.7g**.

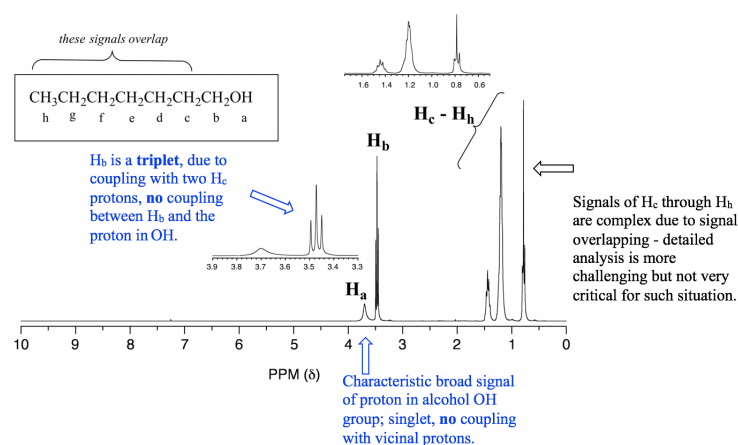

Figure 6.7g The ^1H NMR spectrum of 1-heptanol

6.7.3 ^1H NMR Practice

Signal assignment based on the given structure

With the structure of a compound given, we can apply all the knowledge about ^1H NMR to assign the signals in the spectrum, that is to identify a certain signal comes from which hydrogen(s).

Examples

Match the ^1H NMR spectrum below to its corresponding compound, and assign all of the signals.

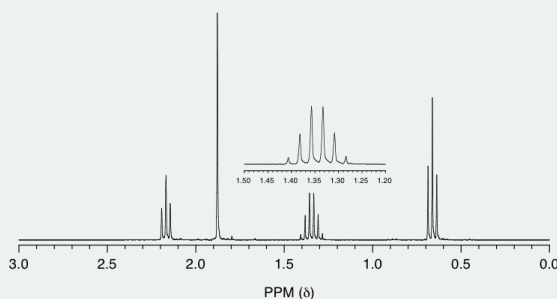

- a) cyclopentanone b) 3-pentanone c) butaldehyde d) 2-pentanone
 e) 4-heptanone f) 1-butene

Approach: It is good idea to draw the structure of each compound and try to see which matches to the spectrum.

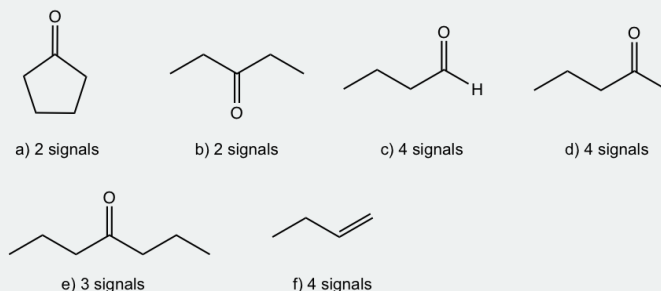

The spectrum has four signals: triplet (~ 0.7 ppm), multiplet (~ 1.4 ppm), singlet (~ 1.9 ppm) and triplet (~ 2.2 ppm). Based on the structure of each compound, compound c), d) and f) should have four signals in the ^1H NMR spectrum.

- There is no signals at about 9 ppm for the aldehyde hydrogens in the spectra, so the spectrum is **not** for compound c), butaldehyde.

- There is no signals at about 4~5 ppm for the alkene hydrogens in the spectra, so the spectrum is **not** for compound f), 1-butene.
- The signals in the spectrum match with what are expected for compound d), 2-pentanone.

Solution: The spectrum is for 2-pentanone.

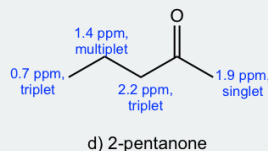

Structure Determination based on ^1H NMR spectrum

For an advanced level of practice, we are supposed to be able to determine the exact structure of a compound with ^1H NMR spectrum given (and other necessary information). As we have learned, there are a lot valuable information about the structure of a compound can be obtained from an ^1H NMR spectrum. For a summary, analyzing the four features of the spectrum is critical to elucidate the structure of a compound:

- The **number of signals** indicate how many different sets of protons there are in the molecule;
- The **chemical shift** of the signal tells us about the electronic environment of each set of protons;
- The **integration** under each signal provides information about how many protons there are in the set being measured (keep in mind that the integration values are for the *ratio*, not actual number of protons);
- The **splitting pattern** of each signal tells about the number of protons on atoms *adjacent* to the one whose signal is being measured.

We'll see examples for structure determination at the end of this chapter.

This page titled [6.7: \$^1\text{H}\$ NMR Spectra and Interpretation \(Part II\)](#) is shared under a [CC BY-NC-SA 4.0](#) license and was authored, remixed, and/or curated by [Xin Liu \(Kwantlen Polytechnic University\)](#).

6.8: ^{13}C NMR Spectroscopy

For carbon element, the most abundant isotope ^{12}C (with ~99% natural abundance) does not have a nuclear magnetic moment, and thus is NMR-inactive. The C NMR is therefore based on the ^{13}C isotope, that accounts for about 1% of carbon atoms in nature and has a magnetic dipole moment just like a proton. The theories we have learned about ^1H NMR spectroscopy also applies to ^{13}C NMR, however with several important differences about the spectrum.

The magnetic moment of a ^{13}C nucleus is much weaker than that of a proton, meaning that ^{13}C NMR signals are inherently much weaker than proton signals. This, combined with the low natural abundance of ^{13}C , means that it is much more difficult to observe carbon signals. Usually, sample with high concentration and large number of scans (thousands or more) are required in order to bring the signal-to-noise ratio down to acceptable levels for ^{13}C NMR spectra.

Chemical Equivalent

For carbons that are chemical equivalent, they only show one signal in ^{13}C NMR as like protons for ^1H NMR. So it is very important to be able to identify equivalent carbons in the structure, in order to interpret ^{13}C NMR spectrum correctly. Taking toluene as an example, there are five sets of different carbon atoms (shown in different colors), so there are five signals in the ^{13}C NMR spectrum of toluene.



toluene molecule has 5 different sets of carbon atoms
(hydrogen atoms are omitted)

Chemical Shift

^{13}C nuclei has different value of g (the magnetogyric ratio) comparing to ^1H nuclei, so the resonance frequencies of ^{13}C nuclei are different to those of protons in the same applied field (referring to **formula. 6.4**, in section 6.5). In an instrument with a 7.05 Tesla magnet, protons resonate at about 300 MHz, while carbons resonate at about 75 MHz. This allows us to look at ^{13}C signals using a completely separate ‘window’ of radio frequencies. Just like in ^1H NMR, tetramethylsilane (TMS) is also used as the standard compound in ^{13}C NMR experiments to define the 0 ppm, however it is the signal from the four equivalent **carbon** atoms in TMS that serves as the standard. Chemical shifts for ^{13}C nuclei in organic molecules are spread out over a much wider range of about 220 ppm (see **Table 6.3**).

Type of Carbon	Chemical Shift (ppm)	Type of Carbon	Chemical Shift (ppm)
$\text{R}-\text{CH}_3$	0 – 35		80 – 150
	15 – 55		110 – 170
	25 – 55		165 – 175
	30 – 40		175 – 185
	10 – 65		190 – 200
(X: Cl, Br or N)			200 – 220
	50 – 90		
	70 – 90		

Table 6.3 Approximate ^{13}C NMR chemical shifts of some common groups

Table 6.3 Approximate ^{13}C NMR chemical shifts of some common groups

The chemical shift of a ^{13}C nucleus is influenced by essentially the same factors that influence the chemical shift a proton: the deshielding effect of electronegative atoms and anisotropy effects tend to shift signals downfield (higher resonance frequency, with

higher chemical shifts). In addition, sp^2 hybridization results in a large downfield shift. The ^{13}C NMR signals for carbonyl carbons are generally the furthest downfield (170-220 ppm), due to both sp^2 hybridization and to the double bond to oxygen.

Integration and Coupling in ^{13}C NMR

Unlike ^1H NMR, the area under a ^{13}C NMR signal **cannot** easily be used to determine the number of carbons to which it corresponds. The signals for some types of carbons are inherently weaker than for other types, for example peaks corresponding to carbonyl carbons are much smaller than those for methyl or methylene (CH_2) peaks. For this reason, signal integration is generally not useful in ^{13}C NMR spectroscopy.

Because of the low natural abundance of ^{13}C nuclei, the spin-spin coupling between two nonequivalent ^{13}C atoms is negligible. ^{13}C nuclei are coupled to nearby protons, however, which results in complicated spectra. For clarity, chemists generally use a technique called **broadband decoupling**, which essentially 'turns off' C-H coupling, resulting in a spectrum in which **all carbon signals are singlets**. Below is the proton-decoupled ^{13}C NMR spectrum of ethyl acetate in CDCl_3 (**Fig. 6.8a**), showing the expected four signals, one for each of the carbons.

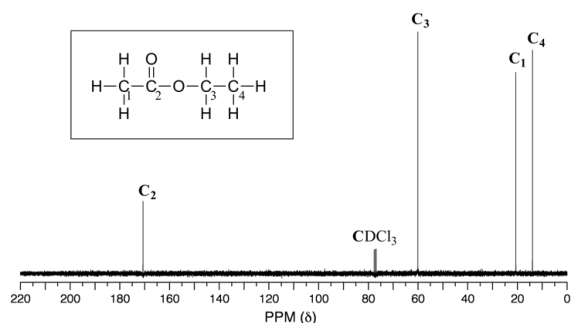
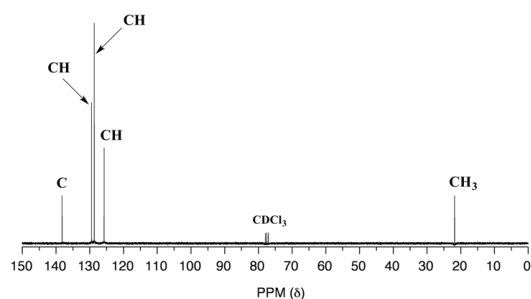
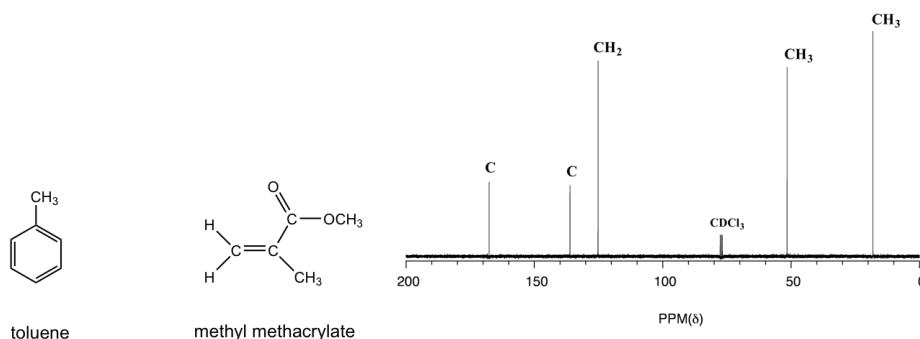

Figure 6.8a The ^{13}C NMR spectrum of ethyl acetate

For our class purpose, ^{13}C NMR spectra are usually used as supporting information to confirm the structure of a compound.

Exercises 6.2

Below are ^{13}C NMR spectra for methylbenzene (common name toluene) and methyl methacrylate. Refer to **Table 6.3** to match the spectra to the correct structure.



Answers to Practice Questions Chapter 6

This page titled [6.8: \$^{13}\text{C}\$ NMR Spectroscopy](#) is shared under a [CC BY-NC-SA 4.0](#) license and was authored, remixed, and/or curated by [Xin Liu](#) ([Kwantlen Polytechnic University](#)).

6.9: Structure Determination Practice

^1H NMR provides a powerful tool for determining the structure of unknown compound. Other than that ^1H NMR, additional information includes molecular formula, IR and ^{13}C NMR spectrum are usually provided as well. Solving the structure of an unknown compound based on all the given information is an important type of question we will work on for this chapter. We will take the $\text{C}_5\text{H}_{12}\text{O}$ constitutional isomer example to go through the strategy for solving this type of question.

Example: Constitutional Isomers with Formula $\text{C}_5\text{H}_{12}\text{O}$

The ^1H NMR below are all for compounds with molecular formula of $\text{C}_5\text{H}_{12}\text{O}$ (the relative integration area for each signal are given as numbers on the spectra). The IR spectra of these compounds do **not** have any strong band at above 3000 cm^{-1} , **nor** are there strong bands at 1700 cm^{-1} . Propose a reasonable structure for each compound that is consistent with the data given.

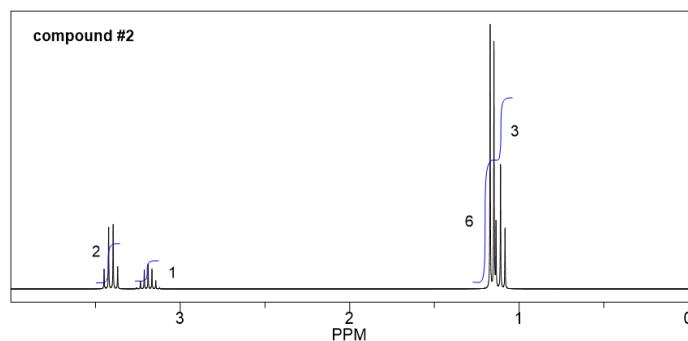
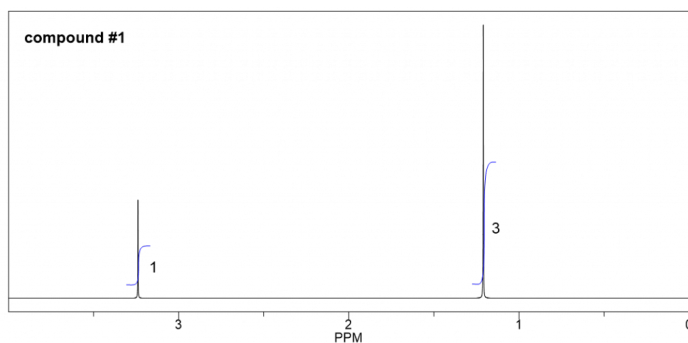

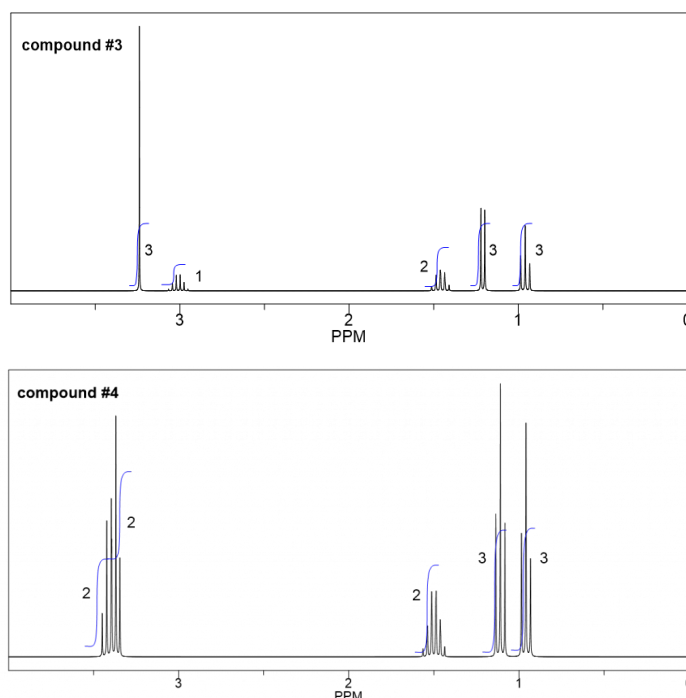

Approach:

Step 1: Calculate the degree of unsaturation (or IHD, [section 2.3](#)) based on the given molecular formula, and get hints about structure/functional group according to the degree of unsaturation. **This is usually the first step to solving this type of question.**

$$\text{Degree of unsaturation} = \frac{(2n+2)-X}{2} = \frac{(2 \times 5 + 2) - 12}{2} = 0$$

From what we learned about the degree of unsaturation, zero degree means there is no any ring nor double bond in the structure, that means all the compounds in this question have *open chain structures with single bonds* only. With one oxygen atom involved, the possible functional group therefore will be **open chain alcohol**, or **open chain ether**.

Step 2: Narrow down the possible functional groups with IR information.

IR indicate that there is **no** any strong bands at above 3000 cm^{-1} for the compound, that exclude the option of alcohol, so the only choice left is the **open chain ether**.

Step 3: Use available spectroscopy data (mainly ^1H NMR, with ^{13}C NMR as supporting if available) to identify discrete parts of the structure.

Step 4 : *Try to put the pieces of the puzzle together, and double check if everything fit the available data.*

Step 3 and 4 are the most challenging parts since there is no simple rule to follow about how to do that. It takes practices to do the interpretation of ^1H NMR signals and translating that into the structure of unknown compound. Checking the four aspects of ^1H NMR as we learned in [section 6.6.5](#). The relative integration areas = given for this question to make it bit easier.

Solutions:

Compound 1:

We can start with the simplest spectrum that have least signals:

- There are only two signals (both are singlet) in this spectrum, indicate that there are two sets of non-equivalent hydrogens.
- The integrations of the two signals are 3 and 1, means the ratio of the number of hydrogens in these two sets are 3:1. And since there are total 12 hydrogens, the actual number of hydrogens should be 9 and 3 in each group.

- 3 hydrogens imply a CH₃ methyl group, and 9 hydrogens could be three CH₃ groups. Also since all the 9 hydrogens are equivalent, that means the three CH₃ groups are equivalent. The only way to have three equivalent CH₃ groups is that there is a *t*-butyl group.
- So the structure is the ether with a methyl group and a *t*-butyl group connected with the oxygen atom.
- The structure of **compound 1** is given below, with the chemical shift valued included.

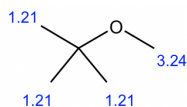

For the remaining compounds, the integration for each signal could be a very good starting point, since generally the integration value indicates the possible structural unit like CH₃, CH₂ or CH. Then the structural units can be put together in a logical way like putting pieces of a puzzle together.

Compound 2:

- Based on the integration, it is determined that there are:
 - one CH₃ group show a triplet;
 - two equivalent CH₃ groups show a doublet;
 - one CH group show a multiplet;
 - one CH₂ group show a quartet.
- The triplet CH₃ could connect with quartet CH₂ as a CH₂CH₃ ethyl group, that makes sense based on the splitting pattern.
- Also, the two equivalent CH₃ groups with a CH could give an isopropyl group, that is consistent to the splitting pattern.
- So the overall structure of **compound 2** is isopropyl ethyl ether.

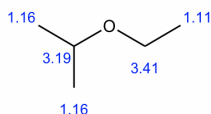

Compound 3:

- Based on the integration, it is determined that there are:
 - one CH₃ group show a triplet;
 - one CH₃ groups show a doublet;
 - one CH₂ group show a multiplet;
 - one CH group show a quartet;
 - one CH₃ group show a singlet.
- The singlet means the CH₃ has no any other hydrogens bonded on adjacent atoms, so the CH₃ group should be bonded with the oxygen atom, and the value of chemical shift (about 3.2 ppm) confirms.
- The triplet CH₃ could connect with quartet CH₂ as a CH₂CH₃ ethyl group, that makes sense based on the splitting pattern.
- The doublet CH₃ groups should connect with a CH group, that is consistent to the splitting pattern.
- The chemical shift (about 3 ppm) and splitting of the CH group (quartet) indicate it should connect to the oxygen atom.
- Put all the above pieces together, the structure of **compound 3** is sec-butyl methyl ether.
-

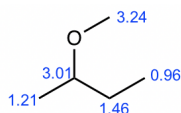

Compound 4

- Based on the integration, it is determined that there are:
 - one CH₃ group show a triplet;
 - another CH₃ groups show a triplet;
 - one CH₂ group show a multiplet;
 - two CH₂ groups with signals overlapping
- The two CH₃ groups both as triplet indicate that they both connect with CH₂, so there are two ethyl CH₂CH₃ groups in the structure, and they are not equivalent.
- Therefore there is only one more CH₂ group left.
- There is only one possible structure with two CH₂CH₃ groups, one CH₂ group and one oxygen atom, so the structure of **compound 4** is ethyl methyl ether.

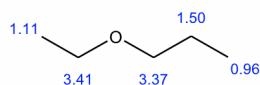

This page titled [6.9: Structure Determination Practice](#) is shared under a [CC BY-NC-SA 4.0](#) license and was authored, remixed, and/or curated by [Xin Liu \(Kwantlen Polytechnic University\)](#).

6.10: Answers to Practice Questions Chapter 6

42

Answers to Practice Questions Chapter 6

Xin Liu

6.1 How many ^1H NMR signals would you predict for each of the following molecules?

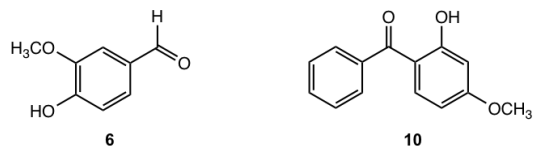
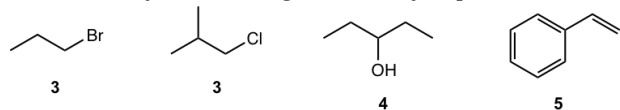

6.2 Below are ^{13}C NMR spectra for methylbenzene (common name toluene) and methyl methacrylate. Refer to **Table 6.3** to match the spectra to the correct structure.

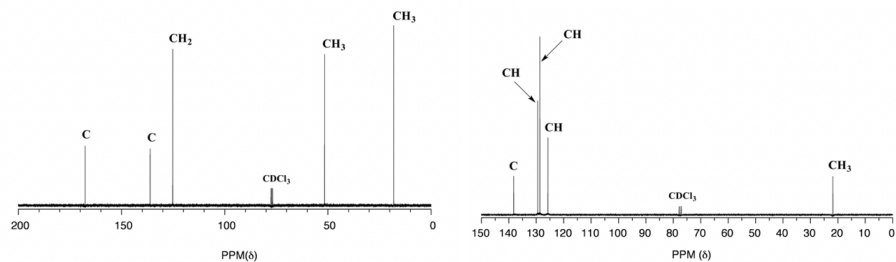

methyl methacrylate

toluene

This page titled [6.10: Answers to Practice Questions Chapter 6](#) is shared under a [CC BY-NC-SA 4.0](#) license and was authored, remixed, and/or curated by [Xin Liu \(Kwantlen Polytechnic University\)](#).

CHAPTER OVERVIEW

7: Nucleophilic Substitution Reactions

- [7.1: Nucleophilic Substitution Reaction Overview](#)
- [7.2: SN2 Reaction Mechanism, Energy Diagram and Stereochemistry](#)
- [7.3: Other Factors that Affect SN2 Reactions](#)
- [7.4: SN1 Reaction Mechanism, Energy Diagram and Stereochemistry](#)
- [7.5: SN1 vs SN2](#)
- [7.6: Extra Topics on Nucleophilic Substitution Reaction](#)
- [7.7: Answers to Practice Questions Chapter 7](#)

This page titled [7: Nucleophilic Substitution Reactions](#) is shared under a [CC BY-NC-SA 4.0](#) license and was authored, remixed, and/or curated by [Xin Liu \(Kwantlen Polytechnic University\)](#).

7.1: Nucleophilic Substitution Reaction Overview

Let's start with a simple substitution reaction example:

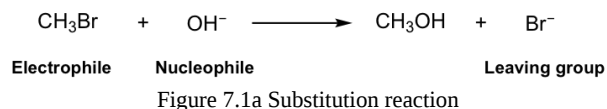

In this reaction, the Br in the reactant methylbromide (CH_3Br) is replaced by the OH group, and the methanol (CH_3OH) is produced as the major product, together with bromide Br^- , the side product. It is easy to understand that this is a substitution reaction, because Br is substituted by OH.

Further discussions on this simple reaction require the introduction of some key terms that are critical in understanding why and how the reaction proceed in this way. These terms are electrophile, nucleophile and leaving group.

Electrophile

The reactant CH_3Br is an alkyl halide. The C-X bond (X: F, Cl and Br) in alkyl halide is polar because halogen is more electronegative than carbon, and as a result carbon has a partial positive charge and halogen has a partial negative charge.



Because of the partial positive charge on carbon, the carbon atom in C-X bond is electron-deficient, and it is going to seek electron-rich reagent to connect with. Such electron-deficient species is called an **electrophile** (*phile* is the Greek suffix means "love"), means the species that loves electrons. The electron-deficient species are usually electrophiles. Other electrophile examples include positive charged ions and atom with incomplete octet, for example: H^+ , CH_3^+ , BH_3 , BeF_2 , AlCl_3 .

For CH_3Br in this reaction, it is the **carbon** atom that act as the electrophile, and the carbon can be called as electrophilic carbon.

The compound CH_3Br that undergoes the substitution usually can be called the substrate. **Nucleophile**

The hydroxide, OH^- , is another reactant in above reaction. It is shown clearly with the Lewis structure of OH^- that the oxygen atom has three lone pair electrons and is negatively charged, so it is an electron-rich species with high electron density.



An electron-rich species is called a **nucleophile** ("nucleo" comes from nucleus, that means positive charge), that is the reagent seeking positively charged or electron-poor species to react with. OH^- is the nucleophile for above reaction. Generally, any species with the electron pair available for sharing could be nucleophile. Nucleophile can be either negatively charged (Nu^-), or neutral ($\text{Nu}:$), for example: OR^- , H_2O , ROH , NH_3 , RNH_2 , RCOO^- are all possible nucleophiles.

Based on the understanding of the concepts of electrophile and nucleophile, you probably realize that a nucleophile could react with an electrophile! Yes, that is the very important and fundamental rule for organic reaction: **when electron-rich nucleophile meet with electron-deficient electrophile, organic reaction would occur.**

Leaving Group

To ensure the above substitution occurs, another critical factor is that the Br must leave together with the electron pairs in C-Br bond, and the bromide, Br^- , is called the leaving group. The leaving group (LG) leaves with the bonding pair of electrons, and is replaced by the nucleophile in the substitution reaction. Without a proper leaving group, even nucleophile is attracted to electrophile, the substitution reaction still cannot move forward. Leaving group can be negatively charged or neutral, as we will see in detailed discussions later.

Applying the three key terms, the above substitution reaction can be summarized as: the nucleophile displaces the leaving group in a substrate, so such reaction is called **nucleophilic substitution reaction**. Nucleophilic substitution reaction could therefore be shown in a more general way:

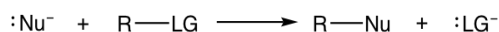

Note: the nucleophile and leaving group are not necessary negatively charged, they could be neutral as mentioned earlier.

Kinetics of Nucleophilic Substitution Reaction

Kinetics is the study that concerns the rate of a chemical reaction, or how fast the reaction occurs. The reaction rate data helps to shine a light on the understanding of reaction mechanism, the step-by-step electron transfer process. Kinetic studies on nucleophilic substitution reactions indicate that there are two different rate law expressions for such reactions. For the two reactions below, reaction 1 is in second order while reaction 2 is in first order. The only reason behind the different kinetic rate is that the reactions go through different reaction mechanism.

Reaction 1:



$$\text{Reaction Rate} = k \times [\text{CH}_3\text{Br}] \times [\text{OH}^-] \quad \text{second-order reaction}$$

Figure 7.1b Reaction 1: second-order reaction

Reaction 1 is the substitution reaction we are familiar with already. It is a second-order reaction. That means the reaction rate depends on the concentration of *both* substrate CH_3Br and nucleophile OH^- . If the concentration of CH_3Br doubled, the reaction rate get doubled, and if the concentration of OH^- doubled, the reaction rate doubled as well. When the concentration of both CH_3Br and OH^- doubled, the reaction rate increased by a factor of *four*.

Reaction 2:



$$\text{Reaction Rate} = k \times [(\text{CH}_3)_3\text{CBr}] \quad \text{first-order reaction}$$

Figure 7.1c Reaction 2: first-order reaction

Reaction 2 is another substitution reaction example. The substrate here is a tertiary bromide and the nucleophile is neutral water molecule. As a first-order reaction, the reaction rate depends **only** on the concentration of substrate $(\text{CH}_3)_3\text{CBr}$ and has nothing to do with nucleophile.

The two types of reactions correspond to two types of reaction mechanism:

- The second-order reaction goes through the bimolecular reaction mechanism that is called **S_N2** reaction, meaning **Substitution, Nucleophilic** and **Bimolecular**.
- The first-order reaction goes through the unimolecular reaction mechanism that is called **S_N1** reaction, meaning **Substitution, Nucleophilic** and **Unimolecular**.

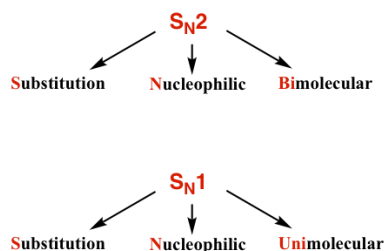

We will have detailed discussions on **S_N2** and **S_N1 mechanism** respectively, and then compare the similarities and differences in between.

This page titled [7.1: Nucleophilic Substitution Reaction Overview](#) is shared under a [CC BY-NC-SA 4.0](#) license and was authored, remixed, and/or curated by [Xin Liu \(Kwantlen Polytechnic University\)](#).

7.2: S_N2 Reaction Mechanism, Energy Diagram and Stereochemistry

S_N2 Reaction Mechanism

Let's still take the reaction between CH₃Br and OH⁻ as the example for S_N2 mechanism.

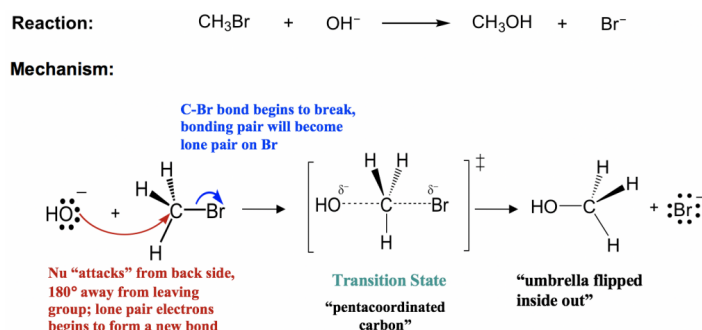

S_N2 mechanism involves two electron pair transfers that occur at the same time, nucleophile attacking (red arrow) and leave group leaving (blue arrow). The nucleophile OH⁻ approaches the electrophilic carbon from the back side, the side that is opposite to the direction that leaving group Br leaves. With the nucleophile OH⁻ getting closer, the Br start to leave as well. The new C—OH bond formation and the old C—Br bond breaking occur *at the same time*. In a very short transient moment, the carbon atom is *partially* connected with *both* OH and Br, that gives a highest energy level state of the whole process called **transition state**. In the transition state of S_N2 reaction, there are *five* groups around the carbon and the carbon can be called "pentacoordinated". As the OH⁻ continues to get closer to the carbon, the Br moves further away from it with the bonding electron pair. Eventually, the new bond is completely formed and the old bond is completely broken that gives the product CH₃OH.

In the mechanism, the reaction proceeds in a single step that involves both nucleophile and the substrate, so increasing the concentration of either of them makes the possibility of collision increase, that explains the **second-order** kinetics of S_N2 reaction. With both nucleophile attacking and leaving group leaving happen at the same time, S_N2 is also said to be a **concerted** mechanism, concerted means simultaneous.

Notes for drawing S_N2 mechanism:

- The **two** arrows must be shown when drawing the S_N2 mechanism. Both have to be shown with the proper direction: nucleophile attack from the direction that is **opposite** to the leaving group leaves, *i.e.*, backside attack.
- The transition state is optional (depends on the requirement of the question). However it is important to understand that the reaction process goes through the transition state before producing the products.
- Please pay attention that for the product, the positions of the three hydrogens around carbon are all pushed to the other side, and the overall configuration of the carbon get *inverted*, like an umbrella flipped inside out in a windstorm. It seems does not really matter for product (CH₃OH) in this reaction, however it does make a difference if the carbon is a chirality center.

Energy Diagram of S_N2 Mechanism

The energy changes for the above reaction can be represented in the energy diagram shown in **Fig. 7.1**. S_N2 is a single-step reaction, so the diagram has only one curve. The products CH₃OH and Br⁻ are in lower energy than the reactants CH₃Br and OH⁻, indicates that the overall reaction is **exothermic** and the products are more stable.

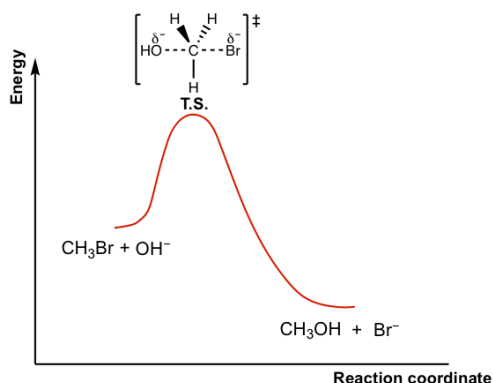

Fig. 7.1 Energy Diagram for S_N2 reaction between CH_3Br and OH^-

The top of the curve corresponds to the **transition state**, which is the highest-energy structure involved in the reaction. Transition state always involves partial bonds, partially formed bond and partially broken bond, and therefore is very unstable with no appreciable lifetime. The transition state therefore can **never** been isolated. The structure of the transition states is usually shown in a square bracket with a double-dagger superscript.

The Effect of Alkyl Halide Structure on S_N2 Reaction Rate

For the discussions on S_N2 mechanism so far, we focused on the reaction of methylbromide CH_3Br . Other alkyl halides could undergo S_N2 reactions as well. The studies on the reaction rate for S_N2 indicate that the structure category of electrophilic carbon in alkyl halide affects the reaction rate dramatically.

Type of Alkyl Halide	Alkyl Halide Structure
Relative Rate	
Methyl	CH_3X
30 Primary (1°) RCH_2-X 1 Secondary (2°)	$\begin{array}{c} R \\ \diagdown \\ CH-X \\ \diagup \\ R' \end{array}$
0.03 Tertiary (3°) (no S_N2 reaction)	$\begin{array}{c} R' \\ \\ R-C-X \\ \\ R'' \end{array}$
negligible	

Table 7.1 Relative Reaction Rate of S_N2 for Different Type of Alkyl Halide

As shown in **Table 7.1**, methyl and primary halides are the substrates with the highest rate, the rate decreases a lot for secondary halides, and the tertiary halides do not undergo S_N2 reaction at all because the rate is too low to be practical.

The **relative reactivity of alkyl halides towards S_N2 reaction** can therefore be summarized as:

methyl > primary 1° > secondary 2° >> tertiary 3°
 too unreactive
 to undergo S_N2
 reaction

Why the trend is like this? This can be explained by the mechanism of S_N2 reaction. Actually this is one of the experiment evidences scientists based on for proposing the mechanism. A key feature in S_N2 mechanism is that the **nucleophile attacks from the back side**. When nucleophile approaching to the carbon, it is easiest to getting close to the methyl carbon because the hydrogen atoms connected on carbon are small in size. With the size of the groups connected on the carbon getting larger, it is becoming more difficult to access to the carbon, and such approaching is totally blocked for tertiary carbon with three bulky alkyl groups connected. Therefore, the reactivity difference is essentially caused by the **steric effect**. **Steric effect** is the effect that based on the steric size or volume of a group. Because of the steric hinderance of bulky groups on the electrophilic carbon, it is less accessible for nucleophile to do back-side attack, so the S_N2 reaction rate of secondary (2°) and tertiary (3°) substrates decreases dramatically. Actually the 3° substrates never go with S_N2 reaction mechanism because the reaction rate too slow.

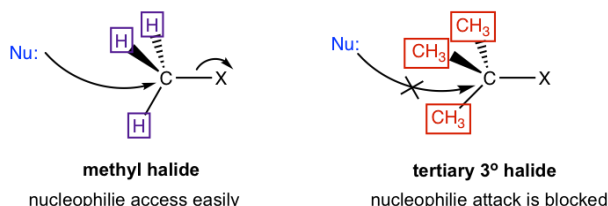

The Stereochemistry of S_N2 Reaction

Another feature of S_N2 reaction mechanism is that the overall configuration of the carbon in the product get inverted comparing to that of the reactant, like an umbrella flipped inside out. Such inversion of configuration is called *Walden inversion*. let's see what is the stereochemistry consequence for such inversion.

Start with the (**R**)-2-bromobutane, the S_N2 reaction produces only one enantiomer of 2-butanol product, and it is predictable that the configuration of the product supposed to be **S** because of the configuration inversion.

Note: Inversion means the arrangement of the groups get inverted, not necessary means the absolute configuration, R/S, inverted. The product does get inverted R/S configuration comparing to the reactant for lot cases, but not guaranteed. The actual configuration of the product has to be determined accordingly.

Exercises 7.1

Show the product of the following S_N2 reaction (CN⁻ is the nucleophile):

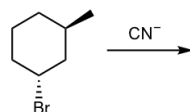

Answers to Practice Questions Chapter 7

This page titled [7.2: SN2 Reaction Mechanism, Energy Diagram and Stereochemistry](#) is shared under a [CC BY-NC-SA 4.0](#) license and was authored, remixed, and/or curated by [Xin Liu \(Kwantlen Polytechnic University\)](#).

7.3: Other Factors that Affect S_N2 Reactions

Leaving Group

When alkyl halides undergo nucleophilic substitution reactions, halogen is the leaving group. Not only halogens can be leaving group, other appropriate groups could be leaving groups as well. Generally speaking, nucleophilic substitution reaction requires good leaving group. How to determine whether a leaving group is good or not then? When leaving group departs, it takes the electron pair from the broken bond together it. So the good leaving group should be the one that can accommodate the electron pair very well with it, or it can be said the good leaving group should be stable with the pair of electrons.

The stability of a group with electron pair is related to the basicity of the group, since basicity means the ability of the species to share its electron pair. As a result, strong base has the high reactivity to share the electron pair, so it is not stable, and cannot be good leaving group. On the other side, weak base with low tendency to share the electron pair, is more stable base and therefore is good leaving group. So the general trend is:

The weaker the basicity of a group, the better leaving group it is .

Our knowledge in acid-base topic will be very helpful here to compare the strength between different leaving groups.

For alkyl halides, the relative reactivities as leaving group is:

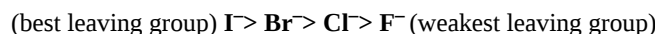

This order matches with the relative basicity of halide anions, I⁻ is the weakest base and also the best leaving group.

Beside halides, other groups can be leaving groups as well. In acid-base chapter we have learned about some examples of strong organic acids, for example, tosylic acid, TsOH, etc. Since the conjugate base of strong acid is very weak bases, the conjugate bases of those acids are good choice of leaving group as well. Examples include (the leaving group is highlighted in blue color):



Figure 7.3a Examples of good leaving groups: Conjugate bases of strong organic acids

Strong bases such as OH⁻, RO⁻, NH₂⁻, R⁻ are therefore very poor leaving groups and **cannot** go with nucleophilic substitution reactions. For OH⁻ or RO⁻ however, upon protonation they can be converted to neutral H₂O or ROH molecules, that are good leaving groups suitable to substitution. This topic will be covered in **section 7.6**.

Note : with the scope of leaving group expanded, the substitution reaction not only limited to alkyl halide. Any compounds with a good leaving group can undergo nucleophilic substitution.

Nucleophile

For S_N2 reaction, nucleophile is one of the rate-determining factors, therefore strong nucleophile helps to speed up S_N2 reactions.

The relative strength of a nucleophile is called nucleophilicity. Nucleophilicity of a nucleophile is measured in terms of the relative rate of its S_N2 reaction with the same substrate. Generally speaking, the nucleophilicity trend depends on several structural features of the nucleophile.

- A nucleophile with negative charge is always stronger than the corresponding neutral one. For example: OH⁻ > H₂O; RO⁻ > ROH.
- Nucleophilicity decrease across a period. For example: NH₃ > H₂O; RNH₂ > ROH
- Nucleophilicity increase across a group. For example:

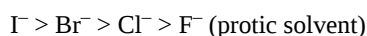
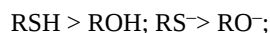

- Smaller group is better nucleophile than bulky group.

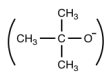
For example, *t*-BuO⁻  is very poor nucleophile because of its bulky size.

To make it more convenient for studying purpose, the commonly applied strong and weak nucleophiles are listed here:

Strong (good) nucleophile: OH^- , RO^- (small alkoxide), RS^- (thiolate), N_3^- (azide), CN^- (cyanide), Cl^- , Br^- , I^- (halide), RCO_2^- (carboxylate), RNH_2 (amine)

Weak (poor) nucleophile: ROH , H_2O , $t\text{-BuO}^-$

With the structure of nucleophiles being so diverse, $\text{S}_{\text{N}}2$ reaction can be used to synthesize the compounds with a variety of functional groups, as shown here.

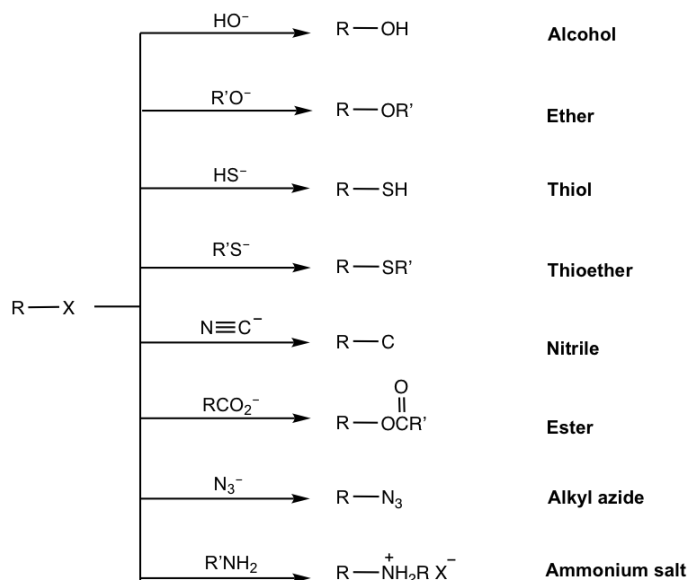

Functional group interconversions via $\text{S}_{\text{N}}2$ reactions

Figure 7.3b Functional group interconversions via $\text{S}_{\text{N}}2$ reactions

Examples

synthesis of ether

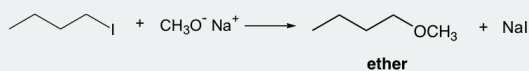

synthesis of ester

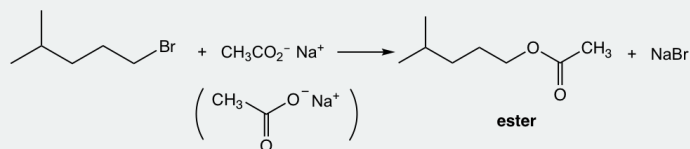

Exercises 7.2

Show reaction mechanism of the above reactions.

Answers to Practice Questions Chapter 7

This page titled [7.3: Other Factors that Affect \$\text{S}_{\text{N}}2\$ Reactions](#) is shared under a [CC BY-NC-SA 4.0](#) license and was authored, remixed, and/or curated by [Xin Liu \(Kwantlen Polytechnic University\)](#).

7.4: S_N1 Reaction Mechanism, Energy Diagram and Stereochemistry

S_N1 Reaction Mechanism

The reaction between *tert*-butylbromide and water proceeds via the S_N1 mechanism. Unlike S_N2 that is a single-step reaction, S_N1 reaction involves multiple steps. Reaction: (CH₃)₃CBr + H₂O → (CH₃)₃COH + HBr

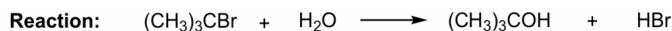

Mechanism:

Step 1 Cleavage of C—Br bond **slowly** to form the carbocation intermediate. Step 1 is the **rate-determining step**.

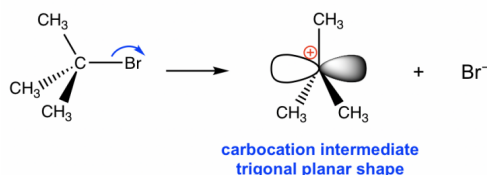

Step 2 Rapid reaction between carbocation intermediate and nucleophile H₂O; H₂O attacks from both sides of the planar carbocation.

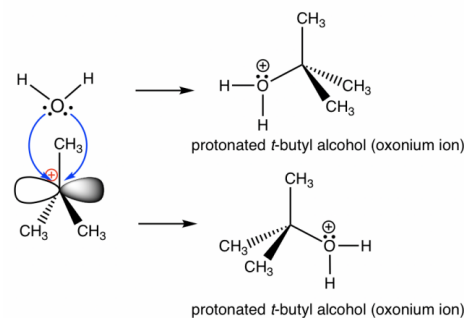

Step 3 Rapid deprotonation to produce neutral final product *t*-butyl alcohol (very fast step, and sometimes can be combined with step 2 together as one step).

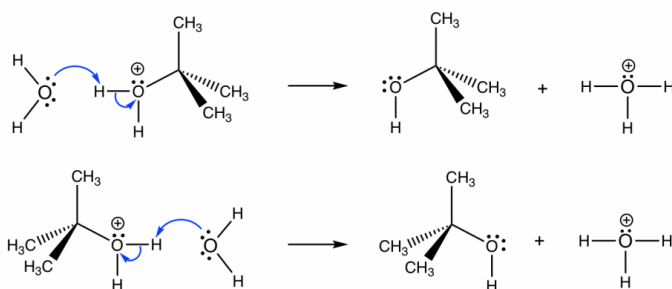

In **step 1**, C—Br bond breaks and Br departs with the bonding electron pair to produce a tertiary carbocation and bromide anion Br⁻. This step only involves a highly endothermic bond-breaking process, and this is the slowest step in the whole mechanism. In multiple-step mechanism, the overall reaction rate is determined by the slowest step, such step is therefore called the **rate-determining step**. In S_N1 reaction, step 1 is the slowest step and therefore the rate-determining step. The rate-determining step only involves the alkyl halide substrate, that is why the overall rate law is in first order, because nucleophile does not participate in the rate-determining step.

The product of step 1, carbocation, will be the reactant of next step and is called the **intermediate** for S_N1 reaction. Intermediate is the unstable, highly-reactive species with very short lifetime. The carbocation intermediate is in trigonal planar shape, with the *empty* 2p orbital particular to the plane. The central carbon is sp² hybridized and has the incomplete octet, so carbocation is the highly reactive intermediate, that is also the electrophile.

Step 2 is the nucleophilic attack step, that the nucleophile H_2O use its lone pair to react with the carbocation intermediate, and produces the protonated *t*-butyl alcohol (oxonium ion). Because of the planar shape of carbocation intermediate, there is same possibility for the nucleophile to attack from either side of the plane, so possible products are generated with the same amounts. For this reaction, attacking from either side gives the same product (both are still shown for the purpose to illustrate the concept); however it gives different stereoisomers if the electrophilic carbon is the chirality center. In **step 3**, a water molecule acting as a Bronsted base to accept the proton from the oxonium ion, and the final neutral product *t*-butyl alcohol is produced. This deprotonation step is very fast, and sometimes can be combined with step 2 together as one step (i.e. step 3 may not be regarded as an individual step).

Energy diagram of $\text{S}_{\text{N}}1$ mechanism

Because $\text{S}_{\text{N}}1$ is a multiple-step reaction, so the diagram has multiple curves, with each step can be represented by one curve. Out of the three steps, the activation energy for step 1 is the highest, therefore step 1 is the slowest step, that is the rate-determining step.

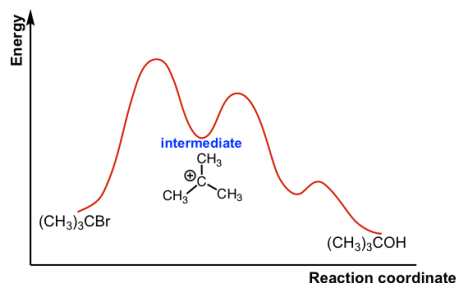

Figure 7.4a Energy diagram for $\text{S}_{\text{N}}1$ reaction between $(\text{CH}_3)_3\text{CBr}$ and H_2O

The connection between the first two curves represent the **carbocation intermediate**. Generally, intermediate is the product of one step of a reaction and the reactant for the next step. Intermediate is at a relatively lower energy level comparing to transition state (which is at the peak of a curve), but intermediate is also highly reactive and unstable.

The Effect of Substrate Structure on $\text{S}_{\text{N}}1$ Reaction Rate

Different substrates have different reaction rates towards $\text{S}_{\text{N}}1$ reaction, and the **relative reactivity of substrates towards $\text{S}_{\text{N}}1$ reaction** can be summarized as:

tertiary 3° > secondary 2° > primary 1° and methyl **too unreactive to undergo $\text{S}_{\text{N}}1$ reaction**

secondary 2 degree > primary 1 degree and methyl (too unreactive to undergo $\text{S}_{\text{N}}1$ reaction)" width="485" height="69"> Figure 7.4b Relative reactivity of substrates towards $\text{S}_{\text{N}}1$ reaction

Comparing this trend to that for $\text{S}_{\text{N}}2$ reaction, you probably realize that they are just opposite. Tertiary substrate is most reactive towards $\text{S}_{\text{N}}1$, but it does not undergo $\text{S}_{\text{N}}2$ at all; primary and methyl substrate are unreactive for $\text{S}_{\text{N}}1$, but they are the best substrates for $\text{S}_{\text{N}}2$. This comparison is very important and useful for us to choose the proper reaction condition for different substrate as we will see in next section. For now, we will need to understand the reasoning of the trend for $\text{S}_{\text{N}}1$.

This is because of the stability of carbocation intermediate. The mechanism shows that a carbocation is formed in the rate-determining step, so the more stable the carbocation, the more easily it is formed, the more it facilitates the rate-determining step and speed up the whole reaction. Therefore the more stable the carbocation intermediate is, the faster the rate of a $\text{S}_{\text{N}}1$ reaction.

The relative stability of carbocation is given below, that the tertiary carbocations are the most stable and methyl carbocation is the least stable.

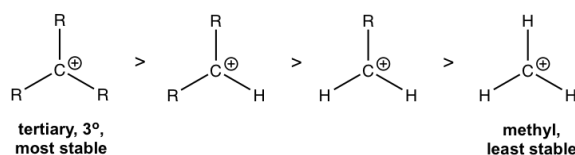

the relative stability of carbocations

Figure 7.4c The relative stability of carbocations

The relative stability of carbocations can be explained by the hyperconjugation effect. **Hyperconjugation** is the partial orbital overlap between filled bonding orbital to an adjacent unfilled (or half-filled) orbital. Carbocation is the electron-deficient species that has the incomplete octet and empty 2p orbital. If there is an alkyl group connected with carbocation, then there are C-C or C-H sigma bonds beside the carbocation carbon, so the filled orbitals of sigma bonds will be able to partially overlap with the empty 2p orbital, therefore sharing the electron density to carbocation and to get the carbocation stabilized. The more R group involved, the stronger hyperconjugation effect is. So tertiary (3°) carbocation is the most stable one. While there is no any R group in methyl carbocation, CH_3^+ , it is least stable.

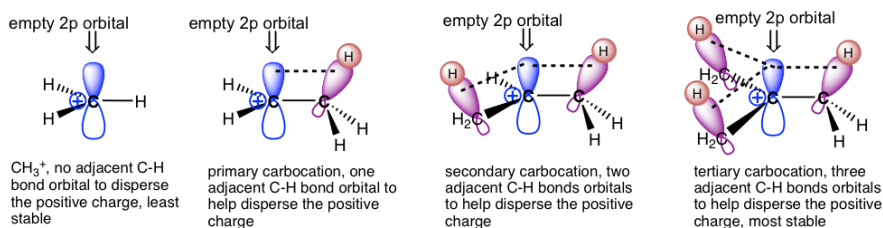

Hyperconjugation effect: electron delocalized from filled C-H orbitals to adjacent empty orbital, and helps to disperse and stabilize the positive charge

Figure 7.4d Hyperconjugation effect

Stereochemistry of $\text{S}_{\text{N}}1$ mechanism

The stereochemistry feature of the $\text{S}_{\text{N}}1$ reaction is very different to that of $\text{S}_{\text{N}}2$, and of course can be explained well with the $\text{S}_{\text{N}}1$ mechanism.

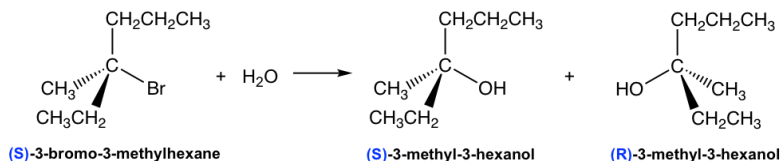

Starting with (S)-3-bromo-3-methylhexane reactant, the $\text{S}_{\text{N}}1$ reaction produces a 50:50 mixture of both R and S enantiomers of 3-methyl-3-hexanol, that is the **racemic mixture** product. This is because the carbocation formed in the first step of an $\text{S}_{\text{N}}1$ reaction has the trigonal planar shape, when it react with nucleophile, it may react from either the front side or the back side, and each side gives one enantiomer. There is equal possibility for reaction to occur from either side, so the two enantiomers are formed with the same amount, and the product is a racemic mixture.

A reaction that converts an optically active compound into a racemic form is said to proceed with **racemization**. For $\text{S}_{\text{N}}1$ reaction that start with (an optical active)one enantiomer as the reactant, and the chirality center is also the electrophilic carbon (i.e. the reaction occurs on the chirality center), it proceeds with racemization as shown above.

Exercises 7.3

Show the detailed mechanism for above reaction of (S)-3-bromo-3-methylhexane and water.

Answers to Practice Questions Chapter 7

Please note that if the chirality center of the reactant is not the reaction center, or if there are more than one chirality center in the reactant, the $\text{S}_{\text{N}}1$ reaction does not produce the racemic mixture as example below.

Examples

Show product(s) of the following $\text{S}_{\text{N}}1$ reaction:

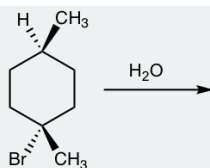

Solution:

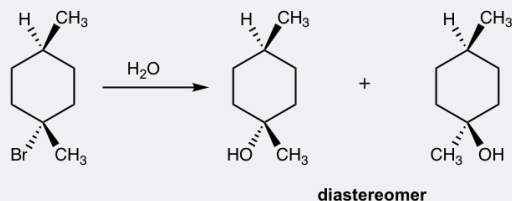

Leaving Group Effect on S_N1

Same as for S_N2 reaction, a good leaving group is also required for S_N1 mechanism, and all the discussions we had before in [section 7.3](#) apply.

Nucleophile

Unlike a S_N2 reaction, the rate-determining step of S_N1 reaction does not include nucleophile, so theoretically the strength of nucleophile has no effect on S_N1 reaction. However, a strong nucleophile has high tendency to go with S_N2 reaction instead of S_N1 , so a weaker nucleophile is a better choice for S_N1 . For the examples we had so far, H_2O is the nucleophile.

In practice, neutral substances such as H_2O , ROH , $RCOOH$ are usually used as nucleophiles in S_N1 reaction. When these substances are applied in the reaction, they serve for another function as solvents. So they are used as *both* nucleophiles and solvents for S_N1 reaction, and such reaction is also called the solvolysis reaction. **Solvolysis reaction** is a nucleophilic substitution in which the nucleophile is a molecule of solvent as well. The term **solvolysis** comes from: *solvent*+*lysis*, that means cleavage by the solvent. A S_N1 reaction is usually a **solvolysis** reaction.

Examples

Show the structures of the products for the following solvolysis reaction.

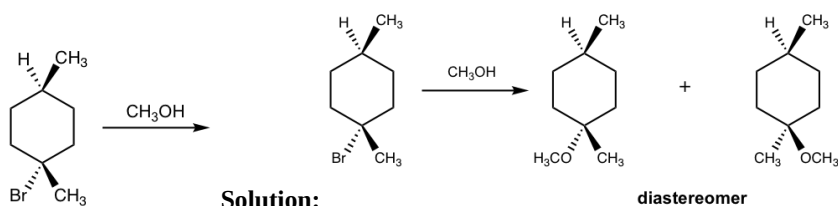

Solution:

diastereomer

This page titled [7.4: \$S_N1\$ Reaction Mechanism, Energy Diagram and Stereochemistry](#) is shared under a [CC BY-NC-SA 4.0](#) license and was authored, remixed, and/or curated by [Xin Liu \(Kwantlen Polytechnic University\)](#).

7.5: SN1 vs SN2

7.5.1 Comparison Between S_N1 and S_N2 Reactions

Till now, we have finished the basic concepts about S_N1 and S_N2 reactions. You probably already noticed that the two type of reactions have some similarities, also quite different though. It will be very helpful to put them together for comparison. To help you get in-depth understanding of the two types of mechanism, it is highly recommended that you have a summary *in your own way*. The following comparison is provided here for your reference.

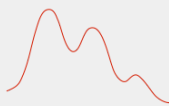
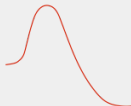
	S _N 1	S _N 2
Rate law	Rate = $k[\text{electrophile}]$	Rate = $k[\text{nucleophile}] \times [\text{electrophile}]$
Mechanism	multiple steps with carbocation intermediate	one step, concerted
Reaction Diagram		
Stereochemistry	racemization on reaction center	inversion on reaction center
Electrophilic Substrate	tertiary 3° > secondary 2° > primary 1° and methyl	primary 1° and methyl > secondary 2° > tertiary 3°
Nucleophile	weak nucleophile, solvolysis	strong nucleophile

7.5.2 Solvent Effect on S_N1 and S_N2 Reactions

Other than the factors we have talked about so far, solvent is another key factor that affect nucleophilic substitution reactions. Proper solvent is required to facilitate a certain mechanism. For some cases, picking up the appropriate solvent is the effective way to control which pathway the reaction proceed.

To understand the solvent effect, we first of all need to have more detailed discussions about solvents, then learn how to choose good solvent for a specific reaction.

Solvents can be divided into **three** major categories based on the structures and polarities, that is: non-polar, polar protic and polar aprotic solvents.

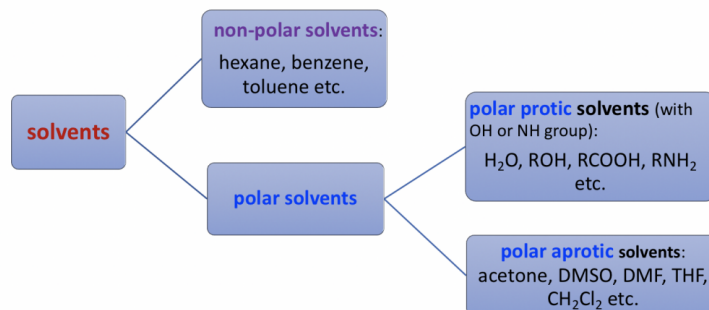

Non-polar solvents are non-polar compounds. (hexane, benzene, toluene, etc.)

Polar protic solvents are the compounds containing OH or NH group that is able to form hydrogen bonds. Polar protic solvents are highly polar because of the OH or NH group.

Polar aprotic solvents is a group solvents with medium range of polarity. They are polar because of polar bonds like C=O or S=O, but the polarity is not as high as OH or NH group. Typical examples of polar aprotic solvents include acetone, DMSO, DMF, THF, CH₂Cl₂.

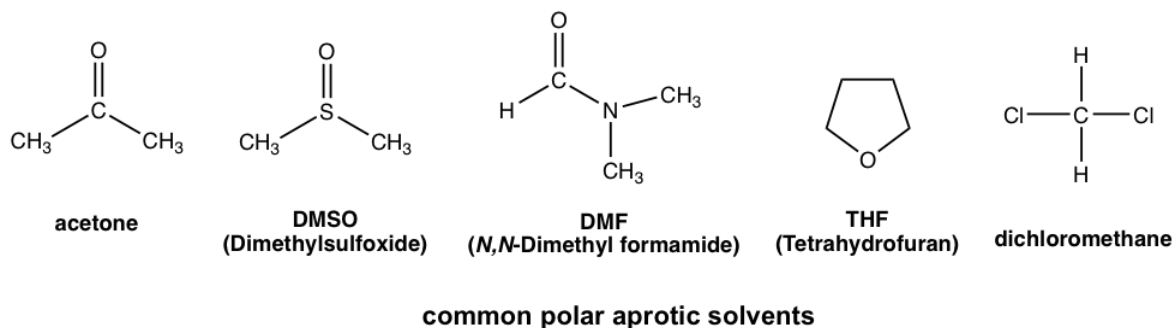

The general guideline for solvents regarding nucleophilic substitution reaction is:

- S_N1 reactions are favored by polar protic solvents (H₂O, ROH etc), and usually are solvolysis reactions.
- S_N2 reactions are favored by polar aprotic solvents (acetone, DMSO, DMF etc).

Polar Protic Solvents Favor S_N1 Reactions

In S_N1 reaction, the leaving group leaves and carbocation formed in the first step, that is also the rate-determining step. The polar solvent, such as water, MeOH, is able to form hydrogen bonding with the leaving group in the transition state of the first step, therefore lowering the energy of the transition state that leads to the carbocation, and speed up the rate-determining step. As a result, polar protic solvents facilitate S_N1 reactions. It is very common that the polar protic solvents serve as nucleophiles as well for S_N1 reactions, so usually S_N1 reactions are solvolysis reactions as we learned earlier.

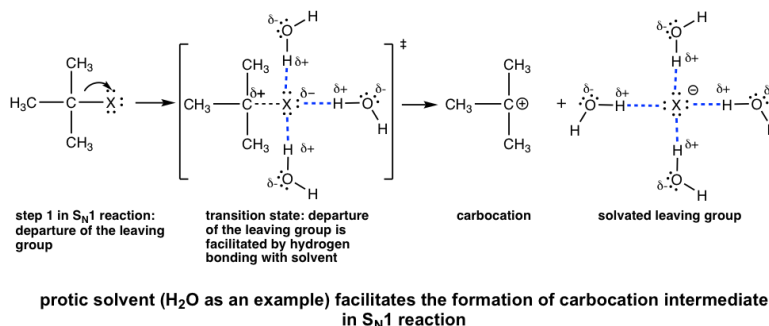
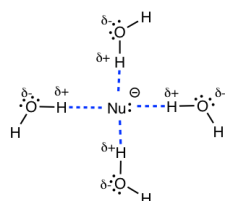

Figure 7.5a Protic solvent (ex. H₂O) facilitates the formation of carbocation intermediate in S_N1 reaction

Polar Aprotic Solvents Favor S_N2 Reactions

Strong nucleophiles are required in S_N2 reactions, and strong nucleophile are usually negatively charged species, such as OH⁻, CH₃O⁻, CN⁻ etc. These anions must stay with cations in salt format like NaOH, CH₃ONa etc. Since salts are insoluble in non-polar solvent, therefore non-polar solvents are not appropriate choices, and we need polar solvents that can dissolve the salts.

The issue for **polar protic** solvent is that the nucleophile anions will be surrounded by a layer of solvent molecules with hydrogen bonds, and this is called the solvation effect. The solvation effect stabilize (or encumber) the nucleophiles and hinder their reactivities in S_N2 reaction. Therefore, polar protic solvents are not suitable for S_N2 reactions.



**protic solvent does not work for S_N2:
nucleophile is solvated and encumbered by protic solvent**

Figure 7.5b Protic solvent does not work for S_N2: nucleophile is solvated and encumbered by protic solvent

As a result the **polar aprotic** solvents, such as acetone, DMSO etc are the best choice of S_N2 reactions. They are polar enough to dissolve the salt format nucleophiles, and also not interact as strongly with anions to hinder their reactivities. The nucleophile anions still move around freely in polar aprotic solvent to act as nucleophile.

The reaction rate for a S_N2 reaction in different solvents are provided in the table below, and the polar aprotic solvent DMF proved to be the best choice that speed up the reaction significantly.

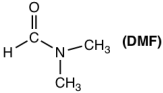
reaction: $\text{CH}_3\text{I} + \text{Cl}^- \rightarrow \text{CH}_3\text{Cl} + \text{I}^-$	
solvent	relative rate
CH_3OH	1
	12.5
 (DMF)	1,200,000

7.5.3 The Choice of Reaction Pathway: S_N1 or S_N2 ?

With all the knowledge about S_N1 , S_N2 reactions and reaction conditions, we should be able to determine that whether a given reaction go with S_N1 or S_N2 pathway, or design a proper reaction that will produce the desired product(s). The reaction pathway predominantly depends on the nature of the substrates (primary, secondary or tertiary), and the choice of proper reaction condition serve as a way to facilitate the process.

- Primary and methyl substrates undergo S_N2 reaction predominantly.
- Tertiary substrates go with S_N1 process.
- The reaction of secondary substrates mainly rely on the conditions applied. The condition include nucleophile, solvent, etc. See examples for more detailed discussions.

Exercises 7.4

Show the product(s) of the following reactions:

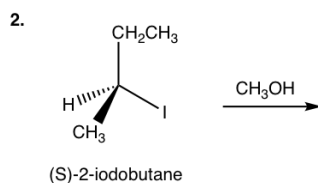
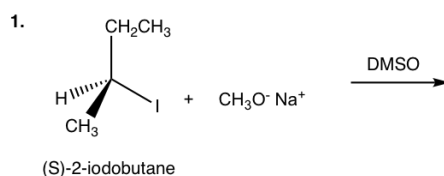
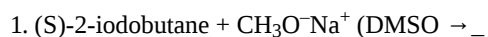

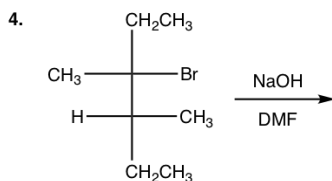
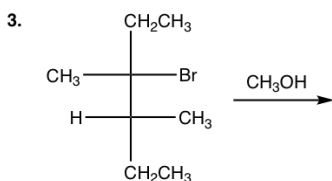

Answers to Practice Questions Chapter 7

Some practical tips for working on S_N1 , S_N2 reactions:

- As we understand that strong nucleophiles are required for S_N2 reaction, and most of the strong nucleophiles are those with negative charges, for example OH^- , OR^- . These nucleophiles can be either shown as anions OH^- , CH_3O^- , $\text{C}_2\text{H}_5\text{O}^-$, **or** in salt format like NaOH , KOH , CH_3ONa , $\text{C}_2\text{H}_5\text{ONa}$ in the reaction conditions. You should understand that it is the same thing. The anion format are easy to identify and also highlight the nature of these species, however since anions must stay together with counter cations as salt, the salt format show the actual chemical formula of the compound used in the reaction.
- Since polar aprotic solvent favors S_N2 reactions, so any of above anions or salt can be used together with DMSO, DMF etc, such as OH^-/DMSO , $\text{CH}_3\text{ONa}/\text{DMF}$ etc .

However, sometimes you may see the combination like $\text{CH}_3\text{ONa}/\text{CH}_3\text{OH}$, that is the combination of CH_3O^- together with its conjugate acid CH_3OH . It may seems contradictory, why a strong nucleophile for S_N2 combine with solvent for S_N1 ? The reality is that CH_3ONa here still act as strong nucleophile and can be used for S_N2 reaction and CH_3OH is the solvent for CH_3ONa . The reason why CH_3OH is used together as solvent is that the CH_3ONa can be prepared by treating an alcohol with Na. For example:

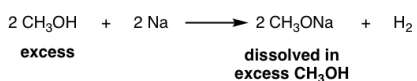

Other alcohol can also react with Na metal (or potassium metal, K) to generate the corresponding RONa .

The reaction between alcohol and NaH can be used as well.



$\text{ROH} + \text{NaH} \longrightarrow \text{RONa} + \text{H}_2$ Since alcohol are in excess in the above reactions, it is also a good solvent for the resulting alkoxide, and RO^-/ROH combination is used commonly together. The RO^- in this combination can be used as strong nucleophile for S_N2 reaction, or base in elimination reaction (**Chapter 8**).

This page titled [7.5: \$S_N1\$ vs \$S_N2\$](#) is shared under a [CC BY-NC-SA 4.0](#) license and was authored, remixed, and/or curated by [Xin Liu \(Kwantlen Polytechnic University\)](#) .

7.6: Extra Topics on Nucleophilic Substitution Reaction

Our discussions so far focus on the fundamental concepts about S_N1 and S_N2 mechanism, and the reactions we learned about proceed in the regular way. There are some other conditions can be “added” to the basic nucleophilic substitution reactions, to make the reaction look different, or more challenge. However, understanding the basic concepts well is very helpful for us to deal with various situations. The reaction may look different, but essentially it is still the same.

7.6.1 S_N1 Reaction with Carbocation Rearrangement

Let's take a look at a S_N1 reaction.

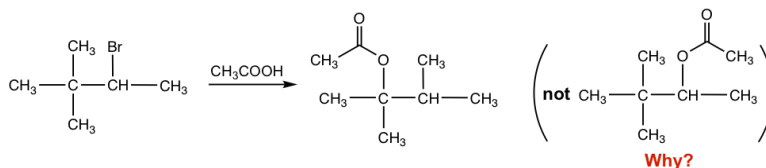

Figure 7.6a Reaction with Carbocation Rearrangement

With the secondary substrate and neutral nucleophile (CH_3COOH), this is a S_N1 reaction, and solvolysis that CH_3COOH acts as both solvent and nucleophile. It is supposed to give the acetate as product, with the acetate replace the Br. However, as shown in the reaction equation that the acetate was **not** introduced on the carbon with leaving group Br, but was connected on the next carbon instead. What is the reason for the unexpected structure of the product?

For reactions involve carbocation intermediate, it is a common phenomena that the carbocation *might* rearrange, if such rearrangement leads to a **more stable** carbocation, and this is called **carbocation rearrangement**. Because of the carbocation rearrangement, the product of the above reaction is different than expected. This can be explained with the step-by-step mechanism below.

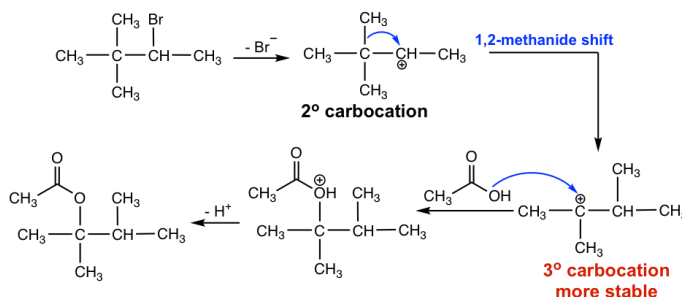

Figure 7.6b Step by step carbocation rearrangement

When Br^- leaves, the initial carbocation formed is a **secondary** one. The CH_3 group on the next carbon then shift with its bonding electrons to the positively charged carbon, and creating a new more stable **tertiary carbocation**. The *tertiary* carbocation then reacts with nucleophile CH_3COOH to give the final acetate product. The CH_3 group shift with the electron pair, and such move is called 1,2-methanideshift. “1,2-“ here refer to the movement occur between two adjacent carbons, not necessarily means C1 and C2.

Other than CH_3 group, the H atom in other reactions could shift as well with the electron pair, if such shift can lead to a more stable carbocation. The shift of hydrogen is called 1,2-hydride shift. A couple of notes about the carbocation rearrangement:

- Any reaction that involves carbocation intermediate might have rearrangement.
- Not all carbocations rearrange. Carbocations **only** rearrange if they become more stable as a result of the rearrangement.
- The shift is usually 1,2-shift, that means it occur between two adjacent carbons.

7.6.2 Intramolecular Nucleophilic Substitution Reaction

For the reactions we learned before, the substrate with leaving group and the nucleophile are always two separate compounds. It is actually possible for one compound containing both leaving group and nucleophile, and the reaction occurs within the same molecule. Such reaction is called the intramolecular (*intra*, Latin for “within”) reaction. Cyclic product is obtained from intramolecular reaction.

Let's talk about the reaction mechanism that rationalize the structure and stereochemistry of the product for following reaction.

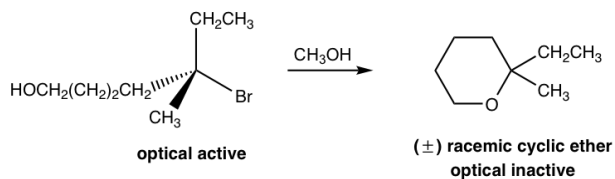

Figure 7.6c Intramolecular Nucleophilic Substitution Reaction

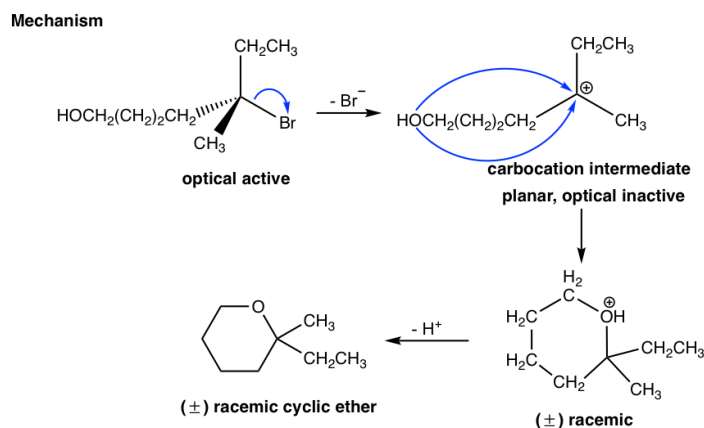

Figure 7.6d Intramolecular Mechanism

In the above reaction, the reactant has two functional groups, bromide (Br) and alcohol (OH). A compound with two functional groups is called **bifunctional molecule**. In this reactant, Br is connected on a tertiary carbon that is a good substrate for $\text{S}_{\text{N}}1$ reaction, and OH is a good nucleophile for $\text{S}_{\text{N}}1$ as well, so the substitution reaction could occur within the same molecule via $\text{S}_{\text{N}}1$ mechanism. So the reaction occurs between one end of the molecule, Br, that acts as the leaving group, and the other part of the molecule, OH, which acts as the nucleophile. As a result, a six-membered cyclic ether is formed as the product.

Since the reaction occurs with $\text{S}_{\text{N}}1$ mechanism, the carbocation intermediate is in trigonal planar shape, and the nucleophile can attack from either side of the carbocation to give both enantiomers. Therefore, the product is the racemic mixture that is optical inactive. This is consistent with the stereochemistry feature of $\text{S}_{\text{N}}1$ reaction we learned before.

Usually if the intramolecular reaction could produce five- or six-membered ring as the product, the reaction will be highly favored because of the special stability of five- or six-membered ring.

7.6.3 Converting Poor Leaving Group to Good Leaving Group

In early discussions about leaving groups (**section 7.3**), we have mentioned the importance of a good leaving group for both $\text{S}_{\text{N}}1$ and $\text{S}_{\text{N}}2$ reactions, that the substitution reaction will not occur is a poor leaving group present. For some situations however, the poor leaving group could be converted to a good leaving group to make the reaction feasible. We will see a couple of strategies for such purpose.

By Acid Catalyst H^+

Example: Propose the mechanism to rationalize the reaction.

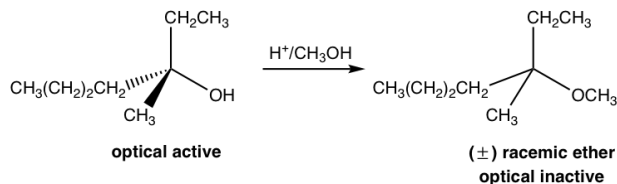

Figure 7.6e Reaction

Mechanism:
Step 1: protonation of OH

Step 2: H₂O departs as leaving group

Step 3: CH₃OH attacks carbocation

Step 4: Deprotonation to give neutral product

Figure 7.6f Mechanism

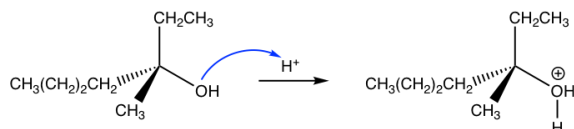
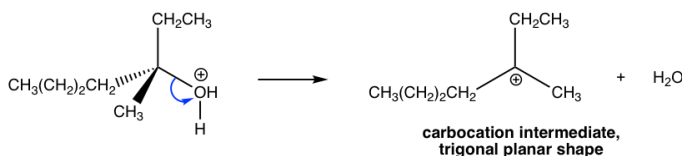
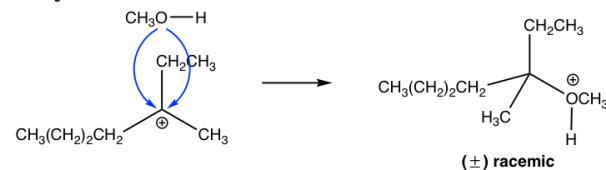
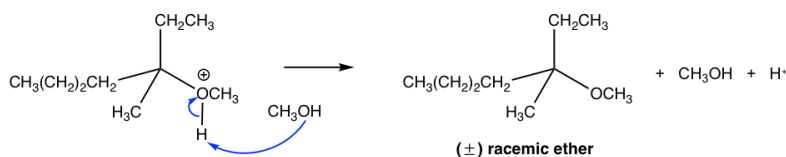
The last three steps in the above mechanism are the standard steps of S_N1 mechanism. However, the reaction won't proceed without the first step. In the first step, which is an acid-base reaction, a proton is rapidly transferred to the OH group, and get the alcohol protonated. By protonation, the OH group is converted to H₂O, that is a much weaker base therefore a good leaving group. In step 2, water molecule departs with the electron pair and leave behind a carbocation intermediate. The following steps are just S_N1, that explains why the product is the racemic mixture. The acid H⁺ was regenerated in step 4 and can be reused for further reactions, therefore only catalytical amount of H⁺ is necessary to start the process.

By Sulfonyl Chloride

Another commonly applied method for converting OH group to a better leaving group is by introducing a sulfonate ester. When alcohol reacts with sulfonyl chloride, with the presence of weak base, the sulfonate ester is formed.

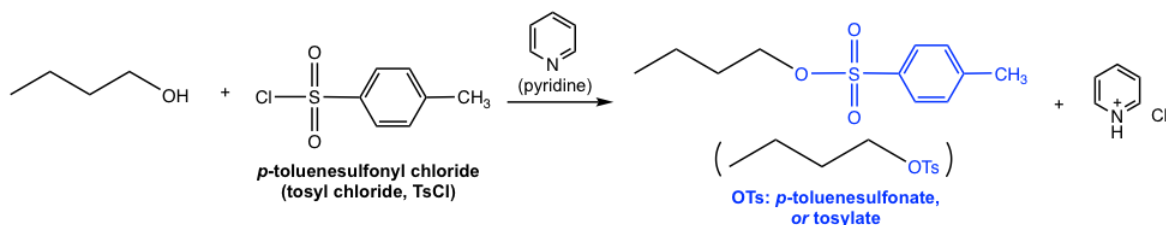

Figure 7.6g Alcohol reacting with tosyl chloride to produce tosylate

As the example shown above, when *p*-toluenesulfonyl chloride (tosyl chloride, TsCl) is used, the resulting ester is *p*-toluenesulfonate (tosylate, OTs). Does tosyl group look familiar to you? Yes, we learned about with this species in **section 3.2**. As the conjugate base of strong acid *p*-toluenesulfonic acid (TsOH), OTs is the very weak base and therefore an excellent leaving group. Pyridine here acts as the weak base to neutralize the side product HCl and facilitate the reaction to completion. The detailed mechanism for this reaction is not required in this course.

Other than introducing OTs, other commonly applied sulfonyl chlorides include MsCl and TfCl, and the sulfonate ester OMs (mesylate) and OTf (triflate) are formed respectively.

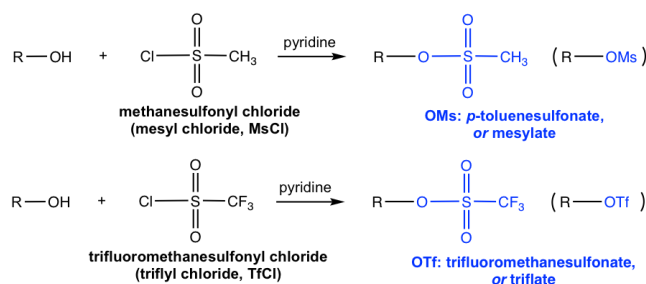

Figure 7.6h Conversion of Alcohol to Mesylate or Triflate

Once the primary alcohol has been converted to OTs (or OMs, OTf), it is then the good substrate for S_N2 reaction. With the appropriate nucleophile added in a separate step, for example CH_3O^- , the S_N2 reaction takes place readily to give ether as the final product, as shown below.

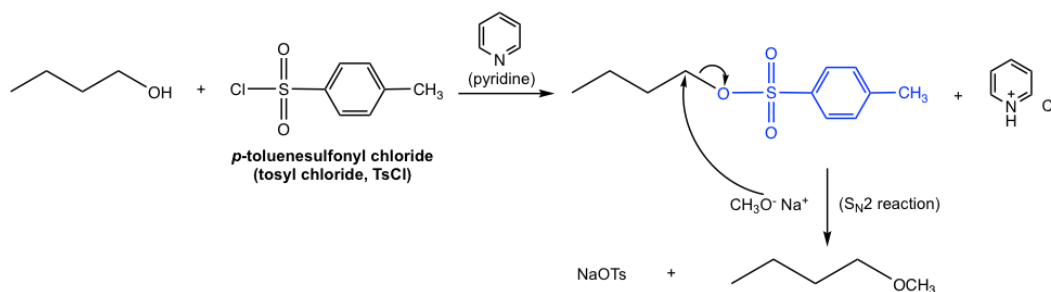

Figure 7.6i Step by step synthesis scheme of butyl methyl ether from 1-butanol (with structures of intermediates shown)

The overall synthesis of butyl methyl ether from 1-butanol involves two separate steps: the conversion of OH to OTs, and then the replacement of OTs by CH_3O through S_N2 reaction. The two steps have to be carried out one after the other, however the whole synthesis scheme can also be shown as below:

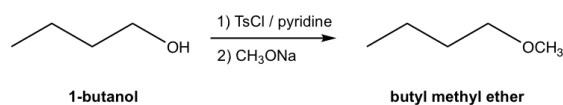

Figure 7.6j Synthesis scheme of butyl methyl ether from 1-butanol (structures of intermediates are NOT shown)

Note:

- Figure 7.6j represents the common and conventional way to show the multiple-step synthesis in organic chemistry. The reaction conditions (reagent, catalyst, solvent, temperature etc.) for each step are shown on top and bottom of the equation arrow. Only the structures of starting material and final product(s) are shown, and the structures of the intermediate products for each step are not included.
- The individual steps need to be labelled as 1), 2) etc. for the proper order, they can not be mixed together.

This page titled [7.6: Extra Topics on Nucleophilic Substitution Reaction](#) is shared under a [CC BY-NC-SA 4.0](#) license and was authored, remixed, and/or curated by [Xin Liu \(Kwantlen Polytechnic University\)](#).

7.7: Answers to Practice Questions Chapter 7

7.1 Show the product of the following S_N2 reaction (CN^- is the nucleophile):

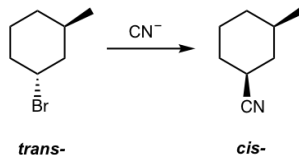

7.2 Show reaction mechanism of the reactions.

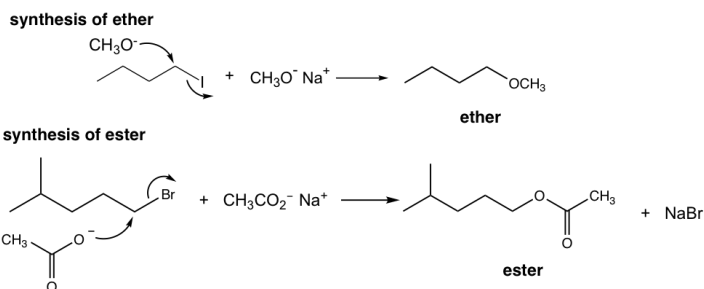

7.3 Show the detailed mechanism for above reaction of (S)-3-bromo-3-methylhexane and water.

7.4 Show the product(s) of the following reactions:

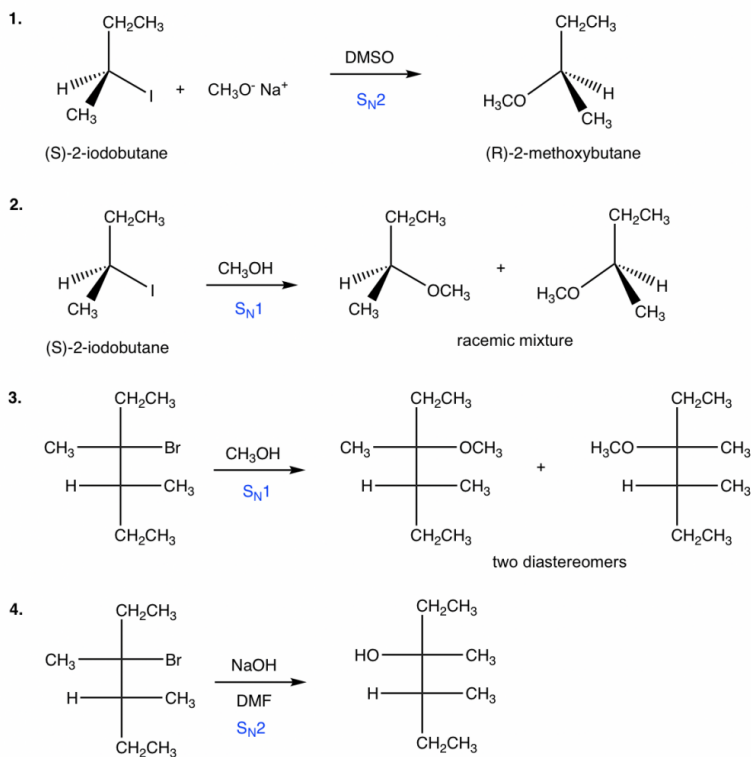

This page titled [7.7: Answers to Practice Questions Chapter 7](#) is shared under a [CC BY-NC-SA 4.0](#) license and was authored, remixed, and/or curated by [Xin Liu \(Kwantlen Polytechnic University\)](#).

CHAPTER OVERVIEW

8: Elimination Reactions

8.1: E2 Reaction

8.2: E1 Reaction

8.3: E1/E2 Summary

8.4: Comparison and Competition Between SN1, SN2, E1 and E2

8.5: Answers to Practice Questions Chapter 8

Thumbnail: *tert*-Butyl cation, demonstrating planar geometry and sp^2 hybridization. (CC BY-SA 3.0; via [Wikipedia](#))

This page titled [8: Elimination Reactions](#) is shared under a [CC BY-NC-SA 4.0](#) license and was authored, remixed, and/or curated by [Xin Liu](#) ([Kwantlen Polytechnic University](#)).

8.1: E2 Reaction

8.1.1 E2 Mechanism

E2 mechanism is the **bimolecular elimination** mechanism, that the reaction rate depends on the concentration of *both* substrate and base. We will take the elimination reaction of 2-bromo-2-methylpropane as an example for discussion.

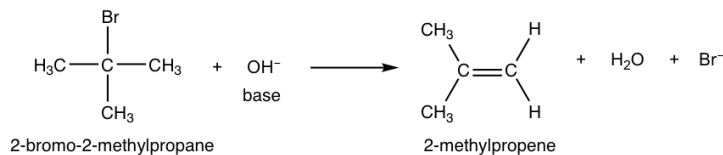

Figure 8.1a Bimolecular Elimination Reaction

It was mentioned earlier that HX is the side product of dehydrohalogenation, why there is no HX (HBr for this reaction) in the reaction equation? It could be understood as that with the presence of excess base (OH^-) in the reaction mixture, HBr reacts with OH^- to give H_2O and Br^- . The following discussion of the mechanism will help you to understand this better.

E2 mechanism is also a single-step concerted reaction, similar to $\text{S}_{\text{N}}2$, with multiple electron pair transfers happen at the same time.

E2 Reaction Mechanism:

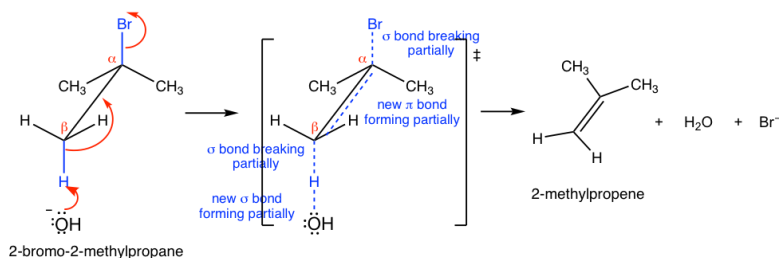

Figure 8.1b E2 Reaction Mechanism

Base, OH^- , uses its electron pair to attack a β -hydrogen on β -carbon, and starts to form a bond; at the same time, the β C-H sigma bond begins to move in to become the π bond of a double bond, and meanwhile Br begins to depart by taking the bonding electrons with it. A transition state is formed in the reaction process with partially breaking and partially forming bonds. At the completion of the reaction, the C=C double bond and H_2O molecule are fully formed, with Br^- leaves completely.

Since both the substrate (halide) and the base are involved in the single-step mechanism, E2 is the second order reaction.

8.1.2 Regioselectivity of E2 reaction: Zaitsev's Rule vs Hofmann Rule

For the reaction we talked in above section, there are three β -carbons in the substrate 2-bromo-2-methylpropane, however they are all *identical*, so the reaction gives only one single elimination product 2-methylpropene.

For other alkyl halides, if there are *different* β -carbons in the substrate, then the elimination reaction may yield more than one products. For example, the dehydrohalogenation of 2-bromo-2-methylbutane can produce two products, 2-methyl-2-butene and 2-methyl-1-butene, by following two different pathways.

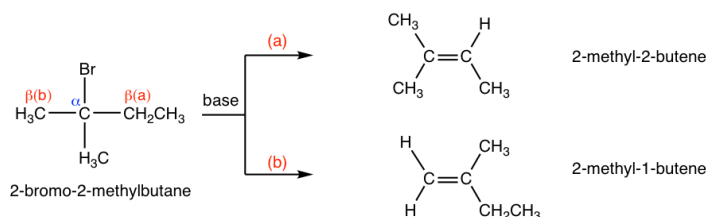

Figure 8.1c Regioselectivity of E2 reaction

Between the two possible products, 2-methyl-2-butene is a trisubstituted alkenes, whereas 2-methyl-1-butene is monosubstituted. For alkenes, the more alkyl groups bonded on the double bond carbons, the more stable the alkene is. Generally, the relative stability of alkenes with different amount of substituents is:

tetrasubstituted > trisubstituted > disubstituted > monosubstituted > ethene

Therefore, 2-methyl-2-butene is more stable than 2-methyl-1-butene. When a small size base is used for the elimination reaction, such as OH^- , CH_3O^- , EtO^- , it turned out that the relative stability of the product is the key factor to determine the major product. As a result, 2-methyl-2-butene is the major product for above reaction.

As a general trend, when small base is applied, the elimination products can be predicted by **Zaitsev's rule**, that said the **more substituted alkene is obtained preferably**. So the Zaitsev's rule essentially can be explained by the higher stability of the more substituted alkenes.



Figure 8.1d Elimination reaction occurs by following Zaitsev's rule with small base applied

However, if a bulky base is applied in the elimination, such as *t*-BuOK, the reaction favors the formation of less substituted alkenes.



Figure 8.1e Elimination reaction occurs following Hofmann rule with bulky base applied

This is mainly because of steric hindrance. With *t*-BuO⁻ attacking the β-hydrogen, it is difficult for this big bulky base to approach the hydrogens from the β-carbon that is bonded with more substituents (as shown in pathway (a) below), while the hydrogen of the methyl group is much easily to be accessed (in pathway (b) instead). When the elimination yields the less substituted alkene, it is said that it follows the **Hofmann rule**.

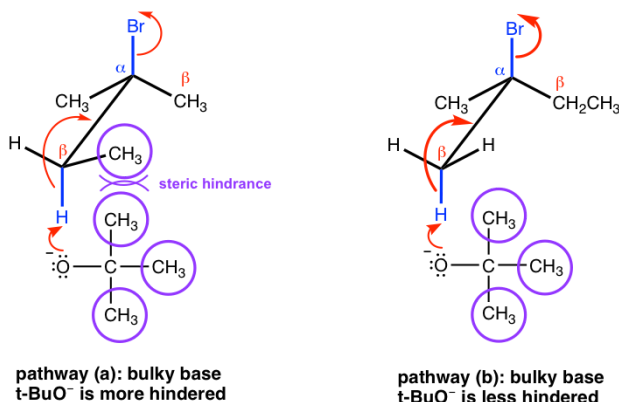
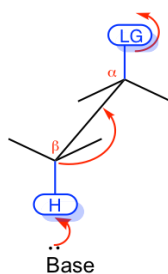

Figure 8.1f Hofmann rule: Bulky base *t*-BuO⁻ (pathway a), Bulky base *t*-BuO⁻ is less hindered

8.1.3 Stereochemistry of E2 Reaction

The E2 mechanism has special stereochemistry requirement to ensure it does proceed. First, the bond connected with the leaving group and the bond connected with the H must be in the same plane, to allow the proper orbital overlapping of the two carbons in the formation of π bond of the alkene product. Second, the leaving group and H must be in anti-position to each other. This is because the anti-position allows the transition state of the reaction is in the more stable staggered conformation, that helps to lower down the energy level of the transition state and speed up the reaction. Overall, E2 reaction proceeds with the leaving group and H are in **anti coplanar** conformation.



Anti coplanar conformation of H and LG is required in E2 mechanism

Figure 8.1g Anti coplanar conformation of H and LG is required in E2 mechanism

Because of the anti-coplanar conformation requirement for E2 reaction, one stereoisomer will be produced preferably over the other, and this is called **stereoselectivity**. For the following example, the elimination of (2*S*,3*S*)-2-bromo-3-phenylbutane produces the *E* isomer specifically, not the *Z* isomer at all. This is because when H is in anti-position to the leaving group Br, the whole compound is in staggered conformation, and the other groups *retain* their relative position in elimination that leads to the *E* isomer.

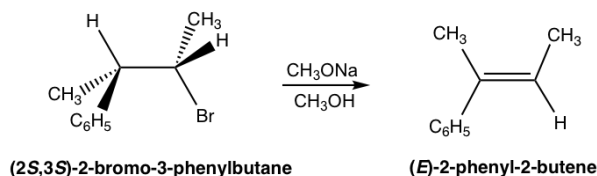

Exercises 8.1

Show elimination product of the following reactions

1.

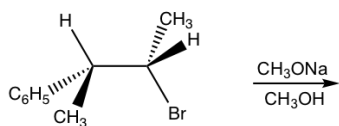

(2*S*,3*R*)-2-bromo-3-phenylbutane

2.

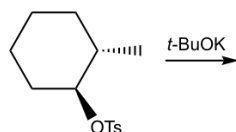

Answers to Practice Questions Chapter 8

8.1.4 Bases in E2 Reactions (Brief Summary)

The most commonly applied bases in E2 reaction are hydroxide OH^- , and alkoxide RO^- . Specifically, the combination of base with corresponding alcohol are used broadly, such as: $\text{CH}_3\text{ONa}/\text{CH}_3\text{OH}$, $\text{C}_2\text{H}_5\text{ONa}/\text{C}_2\text{H}_5\text{OH}$.

Examples of small bases: OH^- , CH_3O^- , $\text{C}_2\text{H}_5\text{O}^-$, NH_2^-

Examples of big bulky bases: $t\text{-BuO}^-$, LDA (lithium diisopropylamide)

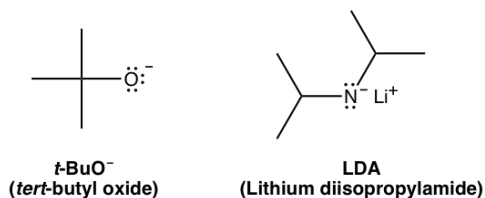

This page titled [8.1: E2 Reaction](#) is shared under a [CC BY-NC-SA 4.0](#) license and was authored, remixed, and/or curated by [Xin Liu \(Kwantlen Polytechnic University\)](#).

8.2: E1 Reaction

E1 Mechanism

Similar to substitutions, some elimination reactions show first-order kinetics. These reactions go through E1 mechanism, that is the multiple-step mechanism includes the carbocation intermediate.

When *t*-butyl bromide reacts with ethanol, small amount of elimination products obtained via E1 mechanism.

Reaction

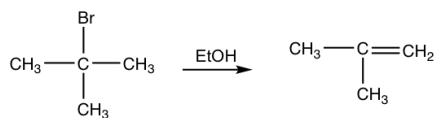

$$\text{Reaction Rate} = k \times [(\text{CH}_3)_3\text{Br}] \quad \text{first-order reaction}$$

The overall elimination involves two steps:

Mechanism

Step 1: Cleavage of C-Br bond **slowly** to form the carbocation intermediate.

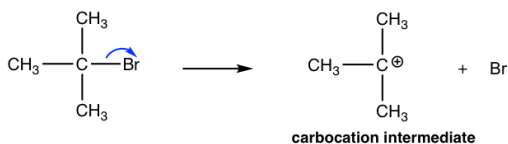

Step 2: base (EtOH) removes H from a β -carbon, and double bond produced.

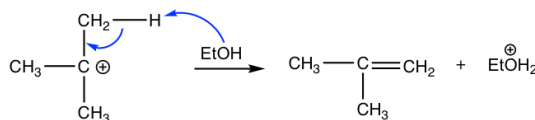

Step 1: The bromide dissociates and forms a tertiary (3°) carbocation. This is a slow bond-breaking step, it is also the rate-determining step for the whole reaction. Since only the bromide substrate involved in the rate-determining step, the reaction rate law is first order. That is the reaction rate only depends on the concentration of $(\text{CH}_3)_3\text{Br}$, and has nothing to do with the concentration of base, ethanol.

Step 2: The hydrogen on β -carbon (β -carbon is the one beside the positively charged carbon) is acidic because of the adjacent positive charge. The base, EtOH, reacts with the β -H by removing it, and the C-H bond electron pair moves in to form the C-C π bond.

The base ethanol in this reaction is a neutral molecule, and therefore a very weak base. Since strong base favors E2, so weak base is a good choice for E1, by discouraging from E2. Ethanol acts as the solvent as well, so E1 reaction is also the **solvolysis** reaction.

For E1 reaction, if more than one alkenes could be possibly formed as product, the major product will also be the more substituted alkene, like E2, because of the stability of those alkenes.

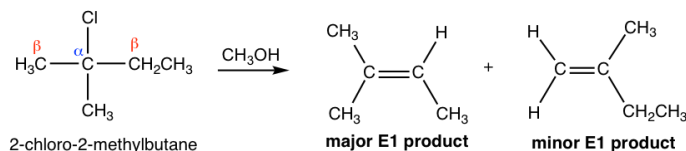

Figure 8.2a Major E1/Minor E1 product

Since E1 reaction involves a carbocation intermediate, the carbocation rearrangement might occur if such rearrangement leads to a more stable carbocation. For the following example, the initially formed secondary carbocation undergoes a 1,2-methanide shift to give the more stable tertiary benzylic carbocation, that lead to the final elimination product.

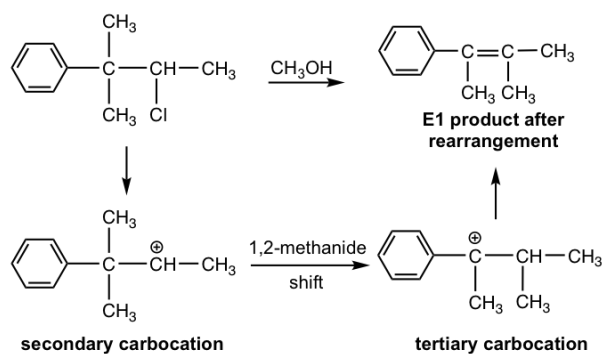
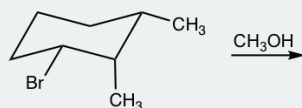
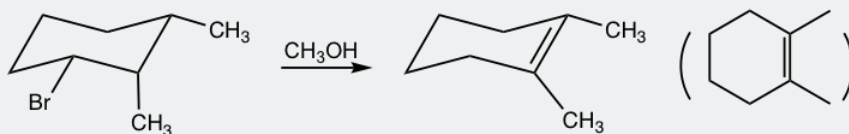

Figure 8.2b secondary and tertiary carbocation

Show elimination product of the following reaction. Examples:



Answer



Mechanism:

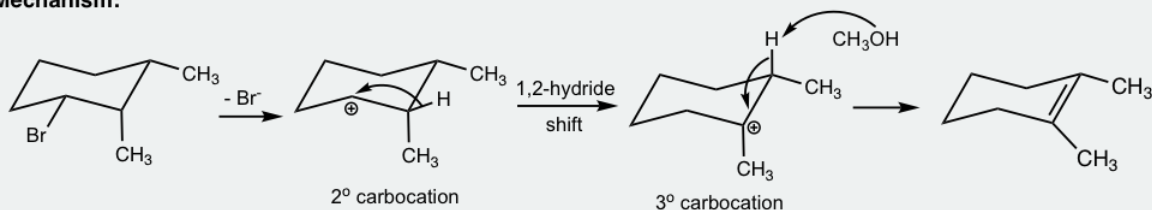

This page titled [8.2: E1 Reaction](#) is shared under a [CC BY-NC-SA 4.0](#) license and was authored, remixed, and/or curated by [Xin Liu \(Kwantlen Polytechnic University\)](#) .

8.3: E1/E2 Summary

The comparison between E1 and E2, in terms of rate law, mechanism, reaction condition etc., are summarized in the following table.

	E1	E2
Rate law	Rate = $k \times [\text{substrate}]$	Rate = $k \times [\text{substrate}] \times [\text{base}]$
Mechanism	multiple steps with carbocation intermediate	one step, concerted
Product	More substituted, more stable alkenes	

small base: more substituted alkenes (Zaitsev's rule)

bulky base: less substituted alkenes (Hoffmann rule)

Substrate tertiary $3^\circ >$ secondary $2^\circ >$ primary 1° (no E1)

tertiary $3^\circ >$ secondary $2^\circ >$ primary 1°

Base weak base, (H_2O , ROH) strong base (OH^- , RO^- , etc.)

The competition between E1 and E2, or whether a substrate goes through E1 or E2 mainly depends on the nature of the substrate, that is:

- Primary 1° substrates go with E2 only, because primary carbocations are too unstable to be formed.
- Secondary 2° and tertiary 3° substrates can go with either E1 or E2 reaction, and appropriate reaction conditions are necessary to facilitate a specific mechanism. E2 reaction is favored by a high concentration of strong base (OH^- , RO^- , or NH_2^-) and a polar aprotic solvent. E1 reaction is favored by a weak base, and polar protic compound, H_2O , ROH, can be both base and solvent (solvolysis).

For study purpose, the comparison between E1 and E2 mechanism help us to understand the two process in depth. In practice, however, the competition between E1 and E2 will not be an issue because they require rather different reaction conditions. More important actually, it is the competition between elimination and substitution. We will have detailed discussions next for the comparison and competition between all the four types of reactions $\text{S}_{\text{N}}1$, $\text{S}_{\text{N}}2$, E1 and E2.

This page titled [8.3: E1/E2 Summary](#) is shared under a [CC BY-NC-SA 4.0](#) license and was authored, remixed, and/or curated by [Xin Liu](#) (Kwantlen Polytechnic University).

8.4: Comparison and Competition Between S_N1, S_N2, E1 and E2

For a certain substrate, it may have chance to go through any of the four reaction pathways. So it seems rather challenging to predict the outcome of a certain reaction. We will talk about the strategies that can be applied in solving such problem, and explain the reasonings behind.

It is very important to understand that the **structural nature of a substrate** (primary, secondary or tertiary) is the most critical factor to determine which reaction pathway it goes through. For example, primary substrates never go with S_N1 or E1 because the primary carbocations are too unstable. If the substrate could go with a couple of different reaction pathways, then the reaction conditions, including the basicity/nucleophilicity of the reagent, temperature, solvent etc., play the important role to determine which pathway is the major one. Our discussions therefore will start from the different type for substrates, then explore the condition effects on that substrate.

Methyl

This is the easiest case. Methyl substrate only go with S_N2 reaction, if any reaction occurs. Elimination is not possible for methyl substrates, and no S_N1 reaction either because CH₃⁺ is too unreactive to be formed, so the only possible way is S_N2.

Primary (1°)

Primary (1°) substrates cannot go with any unimolecular reaction, that is no S_N1/E1, because primary carbocations are too unstable to be formed. Since primary substrates are very good candidates for S_N2 reaction, so **S_N2 is the predominant pathway when good nucleophile is used**. The only exception is that when big bulky base/nucleophile is used, E2 becomes the major reaction.

Examples of reactions for primary substrates:

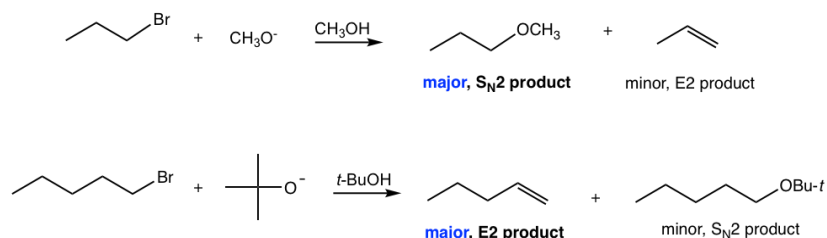

Figure 8.4a Reactions for primary substrates

Secondary (2°)

It is most complicated or challenging to predict the reaction of a secondary substrate (2°), because all the pathways are possible. The reaction conditions then become very key factor. The total four types of reactions can be separated into 3 pathway, that is:

- **E2**: favored by a strong base
- **S_N2**: favored by a good nucleophile (relatively weaker base)
- **S_N1/E1**: It is hard to separate S_N1 and E1 completely apart, because they both go through carbocation intermediates, and are favored by poor nucleophile/weak base, for example, H₂O or ROH (solvolysis). Under such neutral condition, S_N1 and E1 usually occur together for secondary substrates, and **increasing the reaction temperature favors E1 over S_N1**.

It is relatively easy to separate S_N2 and E2 pathways from S_N1/E1, since both S_N2 and E2 require strong nucleophile or strong base that are usually negatively charged species, while S_N1/E1 require neutral conditions.

In order to distinguish S_N2 from E2, we need to be able to determine whether a negatively charged anion is a strong nucleophile (for S_N2) or a strong base (for E2)? All nucleophiles are potential bases, and all bases are potential nucleophiles, because the reactive part of both nucleophile and base is *lone pair electrons*. Whether an anion is a better nucleophile or a better base depends on its basicity, size and polarizability. Generally speaking, the relative stronger bases have the stronger tendency to act as base; and relative weaker base, with small size and good polarizability, have the better tendency to act as nucleophile, see the list given below.

Strong bases: OH⁻, RO⁻(R: small size alkyl group), NH₂⁻

Good nucleophiles (relatively weaker bases): Cl⁻, Br⁻, I⁻, RS⁻, N₃⁻, CN⁻, RCO₂⁻, RNH₂

Please note that bulky bases, such as $t\text{-BuO}^-$ and LDA, always favor E2 and generate elimination products that follow Hofmann rule, because they are too big to do back-side attack in S_N2 .

Examples of reactions for secondary substrates:

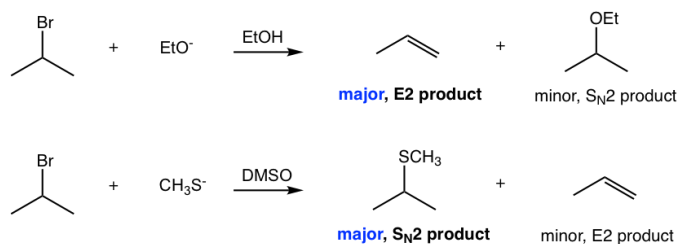

Figure 8.4b Reactions for secondary substrates

Tertiary (3°)

Tertiary (3°) substrates do not go with S_N2 reactions because of steric hindrance. So E2 reaction is the choice when strong base applied, or $S_N1/E1$ pathway with neutral condition (poor nucleophile/weak base). Theoretically speaking, E2 and E1 supposed to give the same elimination product. However, in order to synthesize an alkene from a tertiary substrate, it is a better choice to use a strong base that encourage E2 process rather go with E1. This is because that E1 always combine together with S_N1 , and it is almost impossible to avoid the substitution product.

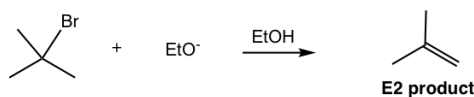

Figure 8.4c Reaction for tertiary substrates

The above discussions can be briefly summarized in the table below, followed by several examples. To predict the reaction outcome, or to design synthesis route for a certain case, it is highly recommend that you **do the analysis by following the logics mentioned above**, instead of just refer to the table. Also, practice makes perfect!

Substrate	Preferred Reaction Pathways
Methyl	S_N2 reaction
Primary	Predominantly S_N2 reaction; Exception: E2 reaction for bulky base
Secondary	

S_N2 reaction with good nucleophile (e.g., RS^- , RCO_2^- , etc)

E2 reaction with strong base (e.g., OH^- , OR^-)

$S_N1/E1$ with neutral condition (e.g., H_2O , ROH)

Tertiary E2 reaction with strong base (e.g., OH^- , OR^-)

$S_N1/E1$ with neutral condition (e.g., H_2O , ROH)

Show major organic product(s) for following reactions. Examples:

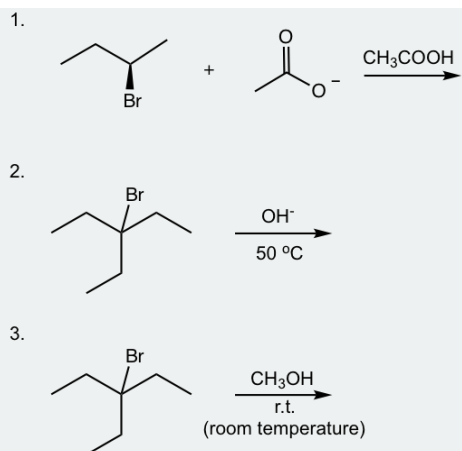

Solutions:

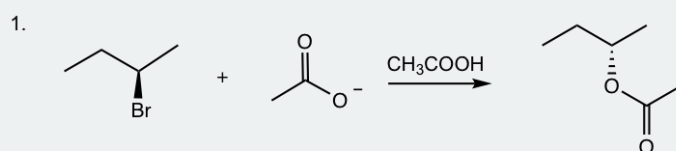

Secondary substrate, with good nucleophile, acetate, which is weak base, so S_N2 is the major pathway. Configuration inverted at the chirality center.

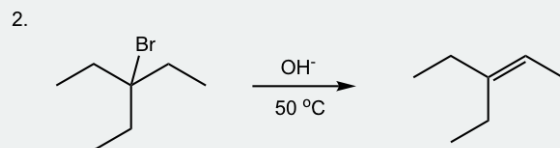

Tertiary substrate with strong base OH^- , therefore $E2$ is the major pathway. The high temperature facilitates the $E2$ reaction.

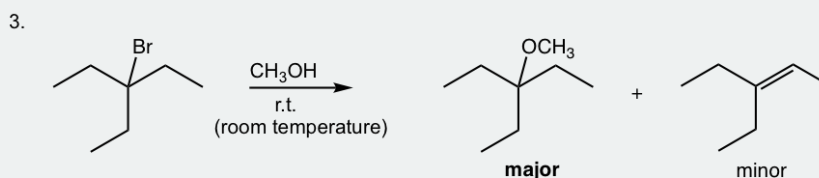

Tertiary substrate in neutral condition, this is solvolysis. CH_3OH is weak nucleophile/weak base and the solvent, so the possible reactions are S_N1 and $E1$. At this low temperature, S_N1 is the major pathway, with bit $E1$ product obtained.

This page titled 8.4: Comparison and Competition Between S_N1 , S_N2 , $E1$ and $E2$ is shared under a [CC BY-NC-SA 4.0](https://creativecommons.org/licenses/by-nc-sa/4.0/) license and was authored, remixed, and/or curated by [Xin Liu \(Kwantlen Polytechnic University\)](https://www.libretexts.org/@page/359613).

8.5: Answers to Practice Questions Chapter 8

8.1 Show elimination product of the following reactions.

1.

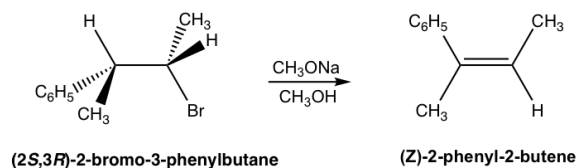

2.

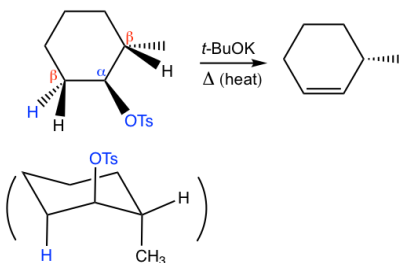

The **anti** coplanar conformation of H and leaving group OTs is shown more clearly in the chair conformation of the cyclohexane. Please note that the other $\beta\text{-H}$ can not be anti to the leaving group OTs. Also, in order to fit to the anti coplanar requirement, both H and OTs have to be in axial positions, so this conformation is the one that undergoes the elimination although it is not the most stable one. Since the most stable conformation does not fit the E2 stereochemistry requirement, so the elimination has to go through the less stable conformation. Heat is preferred to facilitate the reaction.

This page titled [8.5: Answers to Practice Questions Chapter 8](#) is shared under a [CC BY-NC-SA 4.0](#) license and was authored, remixed, and/or curated by [Xin Liu \(Kwantlen Polytechnic University\)](#).

CHAPTER OVERVIEW

9: Free Radical Substitution Reaction of Alkanes

[9.1: Homolytic and Heterolytic Cleavage](#)

[9.2: Halogenation Reaction of Alkanes](#)

[9.3: Stability of Alkyl Radicals](#)

[9.4: Chlorination vs Bromination](#)

[9.5: Stereochemistry for Halogenation of Alkanes](#)

[9.6: Synthesis of Target Molecules- Introduction of Retrosynthetic Analysis](#)

[9.7: Answers to Practice Questions Chapter 9](#)

This page titled [9: Free Radical Substitution Reaction of Alkanes](#) is shared under a [CC BY-NC-SA 4.0](#) license and was authored, remixed, and/or curated by [Xin Liu \(Kwantlen Polytechnic University\)](#).

9.1: Homolytic and Heterolytic Cleavage

For the reactions we learned so far, bond breaking occurs in the way that one part of the bond takes **both** electrons (the electron pair) of the bond away. For example of S_N1 reaction, the leaving group Br leaves with the electron pair to form Br^- and carbocation intermediate.

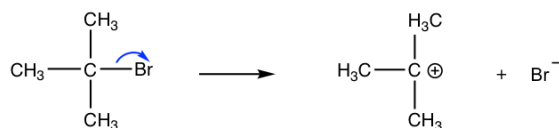

example of heterolytic bond cleavage

This process is called **heterolytic bond cleavage**, the σ bond breaks heterolytically. As we have always been doing, an arrow with the **double-barbs** is used to show heterolytic cleavage, that is the transfer of electron pair specifically:



There is another type of bond breaking process, in which each part of the σ bond takes one electron away, as shown below:

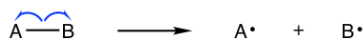

homolytic bond cleavage

This is called **homolytic cleavage**, or **homolysis**. The electron pair separate evenly to each part, and as a result both products contain a single electron. The species that contain one or more single electron is called radical (or free radical). Radicals are produced from homolytic cleavage. The arrow with sing-barb (like the shape of a fishhook) is used to show homolytic cleavage, that is single electron transfer specifically:



Homolysis occurs mainly for non-polar bonds, heat or light (delta is the symbol for heat; $h\nu$ is used to show light) is needed to provide enough energy for initiating the process. For example:

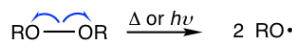
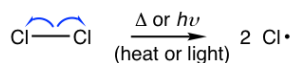

Radical is another highly reactive reaction intermediate, because of the lack of octet. The substitution reaction we will learn in this chapter involves the radical intermediate.

This page titled [9.1: Homolytic and Heterolytic Cleavage](#) is shared under a [CC BY-NC-SA 4.0](#) license and was authored, remixed, and/or curated by [Xin Liu \(Kwantlen Polytechnic University\)](#).

9.2: Halogenation Reaction of Alkanes

When alkanes react with halogen (Cl_2 or Br_2), with heat or light, hydrogen atom of the alkane is replaced by halogen atom and alkyl halide is produced as product. This can be generally shown as:

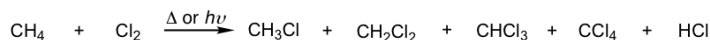
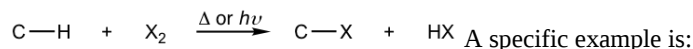

(multi-chlorination products are possible for the reaction)

Such type of reaction can be called as substitution because hydrogen is substituted by halogen; can also be called halogenation because halogen is introduced into the product. For this book, both terms are used in this chapter, interchangeably.

The net reaction for halogenation seems straightforward, the mechanism is more complicated though, it go through multiple steps that include **initiation**, **propagation** and **termination**.

We will take the example of mono-chlorination of methane, for the discussion of reaction mechanism.

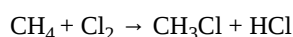

Mechanism for mono-chlorination of methane:

Initiation: Production of radical

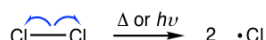

With the energy provided from heat or light, chlorine molecule dissociates homolytically, each chlorine atom takes one of the bonding electrons, and two highly reactive chlorine radicals, $\text{Cl}\cdot$, are produced.

Propagation: Formation of product and regeneration of radical

step 1:

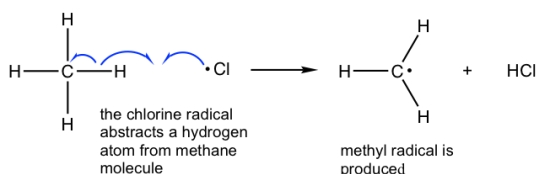

step 2:

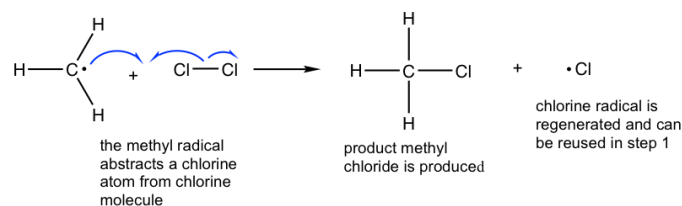

The propagation step involve two sub-steps. In the 1st step, the $\text{Cl}\cdot$ takes a hydrogen atom from the methane molecule (this is also called as **hydrogen abstraction** by $\text{Cl}\cdot$), and C-H single bond breaks homolytically. A new σ bond is formed by Cl and H each donate one electron and HCl is produced as the side product. The CH_3 radical, $\text{CH}_3\cdot$, the critical intermediate for the formation of product in next step, is formed as well.

In the 2nd step, the $\text{CH}_3\cdot$ abstracts a chlorine atom to give final CH_3Cl product, together with another $\text{Cl}\cdot$. The regenerated $\text{Cl}\cdot$ can attack another methane molecule and cause the repetition of step 1, then step 2 is repeated, and so forth. Therefore the regeneration of the $\text{Cl}\cdot$ is particularly significant, it makes the propagation step self-repeat hundreds or thousands of time. The propagation step is therefore called the self-sustaining step, only small amount of $\text{Cl}\cdot$ is required at the beginning to promote the process.

Initiation and propagation are productive steps for the formation of product. This type of sequential, step-wise mechanism in which the earlier step generate the intermediate that cause the next step of the reaction to occur, is call the **chain reaction**.

The chain reaction will not continue forever though, because of the termination steps.

Termination: Consumption of radicals

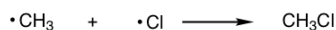

$\cdot\text{CH}_3 + \cdot\text{CH}_3 \longrightarrow \text{CH}_3\text{CH}_3$ When two radicals in the reaction mixture meet with each other, they combine to form a stable molecule. The combination of radicals lead to the decreasing of the number of radicals available to propagating the reaction, and the reaction slows and stops eventually, so the combination process is called termination step. A few examples of termination are given above, other combinations are possible as well.

The propagation steps are the core steps in halogenation. The energy level diagram helps to provide further understanding of the propagation process.

The 1st step in propagation is endothermic, while the energy absorbed can be offset by the 2nd exothermic step. Therefore the overall propagation is exothermic process and the products are in lower energy level than reactants.

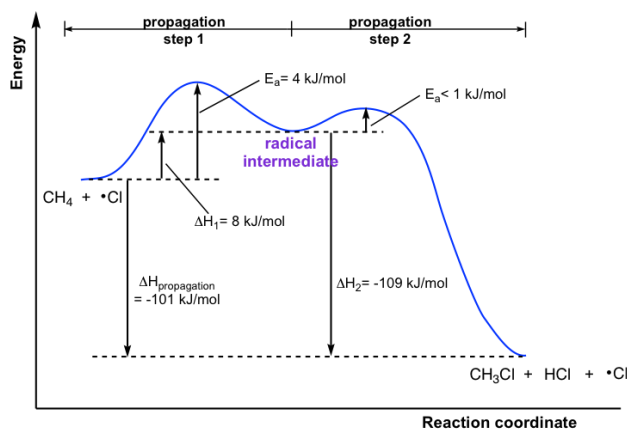

Energy diagram of mono-chlorination of methane

The reaction heat (enthalpy) for each of the propagation step can also be calculated by referring to the homolytic bond dissociation energies (**Table 9.1**). For such calculation, energy absorbed for bond-breaking step, so the bond energy was given “+” sign, and energy released for bond-forming step, and the “-” sign applied.

Bond	kJ/mol	Bond	kJ/mol	Bond	kJ/mol
A — B → A • + B •					
F — F	159	H — Br	366	CH ₃ — I	240
Cl — Cl	243	H — I	298	CH ₃ CH ₂ — H	421
Br — Br	193	CH ₃ — H	440	CH ₃ CH ₂ — F	444
I — I	151	CH ₃ — F	461	CH ₃ CH ₂ — Cl	353
H — F	570	CH ₃ — Cl	352	CH ₃ CH ₂ — Br	295
H — Cl	432	CH ₃ — Br	293	CH ₃ CH ₂ — I	233

Table 9.1 Homolytic Bond Dissociation Energies for Some Single Bonds

Examples

Calculation reaction energy for the propagation step of mono-chlorination of methane (referring to the corresponding bond energies in Table 9.1.)

Solution:



The $\text{H} - \text{CH}_3$ bond broken, absorb energy, so +440 kJ

The $\text{H} - \text{Cl}$ bond formed, release energy, so - 432 kJ

$$\Delta H_1 = +440 + (-432) = +8 \text{ kJ}$$

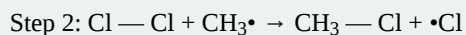

The $\text{Cl} - \text{Cl}$ bond broken, absorb energy, so +243 kJ

The $\text{CH}_3 - \text{Cl}$ formed, release energy, so -352kJ

$$\Delta H_2 = +243 + (-352) = -109 \text{ kJ}$$

$$\Delta H_{\text{propagation}} = \Delta H_1 + \Delta H_2 = +8 + (-109) = -101 \text{ kJ}$$

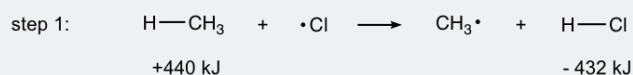

$$\Delta H_1 = +440 + (-432) = +8 \text{ kJ}$$

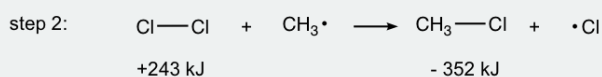

$$\Delta H_2 = +243 + (-352) = -109 \text{ kJ}$$

$$\Delta H_{\text{propagation}} = \Delta H_1 + \Delta H_2 = +8 + (-109) = -101 \text{ kJ}$$

The calculated data does match with the data from the energy diagram.

Reactivity Comparison of Halogenation

The energy changes for halogenation (substitution) with the other halogens can be calculated in the similar way, the results are summarized in **Table 9.2**.

Reaction	F ₂	Cl ₂	Br ₂	I ₂
Step 1: $\text{H} - \text{CH}_3 + \cdot\text{X} \rightarrow \text{CH}_3\cdot + \text{H} - \text{X}$	-130	+8	+74	-142
Step 2: $\text{X} - \text{X} + \text{CH}_3\cdot \rightarrow \text{CH}_3 - \text{X} + \cdot\text{X}$	-322	-109	-100	-89
Overall propagation: $\text{H} - \text{CH}_3 + \text{X} - \text{X} \rightarrow \text{CH}_3 - \text{X} + \text{HX}$	-452	-101	-26	+53

Table 9.2. Enthalpy of the Propagation Steps in Mono-halogenation of Methane (kJ/mol)

The data above indicate that the halogen radicals have different reactivity, fluorine is most reactive and iodine is least reactive. The iodine radical is very unreactive with overall “+” enthalpy, so iodine does not react with alkane at all. On the other side, the extreme high reactivity of fluorine is not a benefit either, the reaction for fluorine radical is so vigorous or even dangerous with lots heat released, and it is not practical to apply this reaction for any application because it is hard to control it. So Cl₂ and Br₂, with reactivity in the medium range, are used for halogen substitutions of alkanes. Apparently Cl₂ is more reactive than Br₂, and this leads to the different selectivity and application between the two halogens, more discussions in **section 9.4**.

This page titled [9.2: Halogenation Reaction of Alkanes](#) is shared under a [CC BY-NC-SA 4.0](#) license and was authored, remixed, and/or curated by [Xin Liu \(Kwantlen Polytechnic University\)](#).

9.3: Stability of Alkyl Radicals

Alkyl radical is the key intermediate for halogenation reaction of alkanes, so the relative stability of radical determines the relative reactivity. Based on the energy diagram, the alkane that generate the more stable carbon radical exhibits the higher reactivity.

The alkyl radicals with different structures show different stabilities. Specifically, tertiary radical is most stable and the primary and methyl radicals are least stable, that follow the same trend as the stability of carbocations.

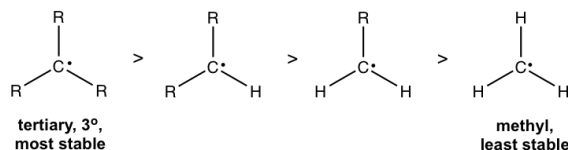

the relative stability of alkyl radicals

This trend can be explained by two reasonings:

- **Hyperconjugation effect** of alkyl (R) group: alkyl groups are electron-donating groups through hyperconjugation effect (refer to [section 7.4](#)), that is the electron density of C-C or C-H σ bond overlap with the half-filled p orbital of carbon radical. Similar to the carbocation, carbon radical is also the electron deficient species, so the electron-donating effect of alkyl groups help to stabilize it. With more alkyl groups involved, the radical is more stable.
- **Homolytic bond dissociation energy** comparison: Homolytic cleavage of C-H bond produces carbon radical. The C-H bond in different structure has different bond dissociation energy. Let's compare two different types below, primary vs secondary:

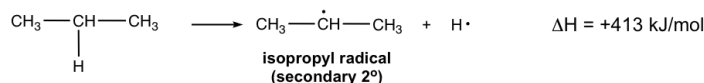
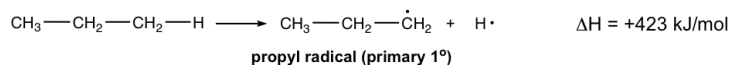

Since both radicals come from the same compound, propane, so the higher the homolytic bond dissociation energy means the higher the energy level of the resulting carbon radical. The bond energy of the 1° C-H is 10 kJ/mol higher in energy than the bond energy of the 2° C-H, therefore the secondary radical is more stable than the primary one.

Other than the above reasons, there is another effect that affect the stability of radicals. For example, the following radical exhibits special stability, that is even more stable than other regular tertiary radical, although it is a primary radical. Why? This is because of another effect — **resonance effect**!

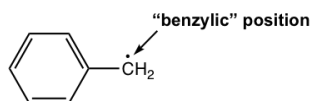

benzylic radical

The radical here is not a regular primary radical, it is on the position that is beside the benzene ring. The position right next to the benzene ring is call the **benzylic** position, and this radical is a **benzylic radical**. Because of the presence of benzene ring, the benzylic radical has total five resonance contributors. According to resonance effect, the more resonance contributors available, the better the electron density dispersed, the more stable the species is.

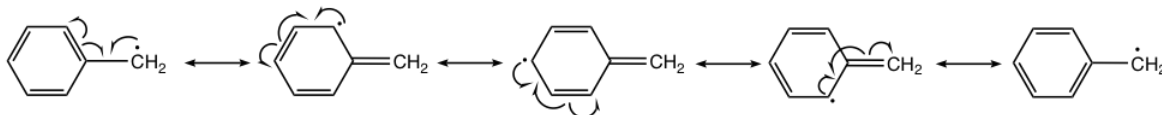

resonance effect: benzylic radical is stabilized by resonance structures

The resonance effect also helps to stabilize the **allylic radical** as well. The carbon that is right next to the C=C double bond is the **allylic** position. The resonance structures of an allylic radical example are shown below. Both benzylic and allylic radicals are more stable than the tertiary alkyl radicals because of resonance effects.

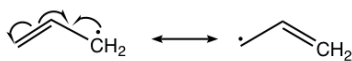

allylic radical is stabilized by resonance structures

This page titled [9.3: Stability of Alkyl Radicals](#) is shared under a [CC BY-NC-SA 4.0](#) license and was authored, remixed, and/or curated by [Xin Liu](#) (Kwantlen Polytechnic University).

9.4: Chlorination vs Bromination

9.4.1 Monochlorination

First we will focus on monochlorination product, by assuming that chlorination only occur once. Since chlorine is a rather reactive reagent, it shows relative *low selectivity*, that means Cl_2 does not discriminate greatly among the different types of hydrogens atoms (primary, secondary or tertiary) in an alkane. As a result, for the reaction of alkane with different hydrogen atoms, a mixture of isomeric monochlorinated products are obtained.

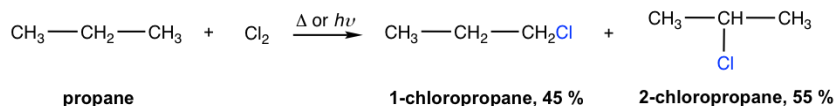

Figure 9.4a Monochlorination products

The experimental results of the monochlorination of propane indicate that 45% primary chloride (1-chloropropane) and 55% secondary chloride (2-chloropropane) are produced. How to explain this result?

To predict the relative amount of different chlorination product, we need to consider two factors at the same time: *reactivity* and *probability*.

It has been discussed in **section 9.3**, that different radicals (primary, secondary or tertiary) have different stability and reactivity. **The relative reaction rate of alkyl radicals for chlorination** have been measured and has the approximate values of:



Figure 9.4b Relative reaction rate of alkyl radicals for chlorination

Probability simply depends how many hydrogen atoms are there for each type. With more hydrogen atoms available, the chance for that type of hydrogen to react is higher statistically.

So the overall amount of each isomeric product should be estimated by accounting for both reactivity and probability, that is:

the amount of a certain type of product = number of that type of hydrogens \times relative reactivity

For the example of monochlorination of propane, the calculation is:

Amount of 1-chloropropane: 6 (number of 1° hydrogens) \times 1.0 (relative reactivity) = 6.0

Amount of 2-chloropropane: 2 (number of 2° hydrogens) \times 3.8 (relative reactivity) = 7.6

yield % of 1-chloropropane: $6.0/13.6 = 44 \%$

yield % of 2-chloropropane $7.6/13.6 = 56 \%$

The calculated values are consistent with the experiment results.

Exercises 9.1

Predict the percentage yield of each product for monochlorination of isobutane by calculation, and compare your calculated numbers to the experiment results. Are they consistent?

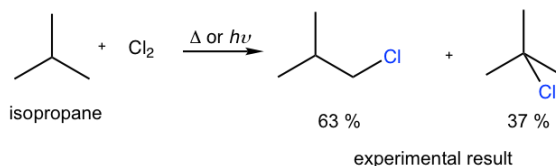

Answers to Practice Questions Chapter 9

For the alkane with only one type of hydrogen, the problem of isomeric mixture can be prevented of course since only one product produced. For the following chlorination of cyclopentane, only one monochloride is produced.

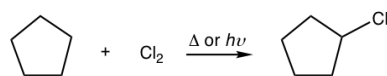

Figure 9.4c Chlorination of cyclopentane

9.4.2 Multichlorination

Although we assume that chlorination occurs once in last section discussions, this is not the actual case unfortunately. A common issue with chlorination is that multiple substitution always happen. A simple example is the chlorination of methane, that a mixture of multiple chlorination product were obtained as we learned before.

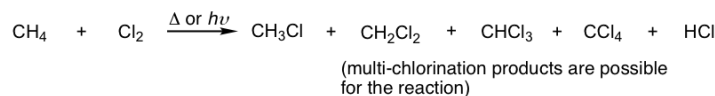

Figure 9.4d Example of multichlorination products

The mechanism for the formation of multichlorination product is similar to that of monochloride. When chloromethane (or methylchloride) reacts with Cl_2 , another hydrogen is replaced by chlorine atom to give dichloromethane, dichloromethane reacts with Cl_2 again to give trichloromethane, and trichloromethane reacts further to produce tetrachloromethane. All the reactions still go through similar propagation steps with radical mechanism.

Examples

Show the mechanism of propagation steps for the formation of dichloromethane from chloromethane.

Solution:

propagation step 1:

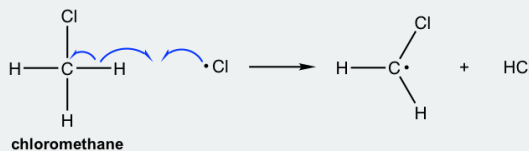

step 2:

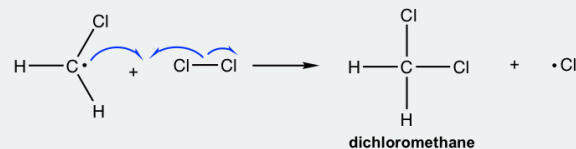

Practically, to minimize the problem of multichlorination products, the reaction conditions can be controlled in certain ways, for example:

- Use high concentration of alkane relative to Cl_2 , to decrease the possibility of multichlorination;
- Control reaction time: stop reaction after “short” time to favor monochlorination product.

These methods help to reduce the amount of multichlorination products, but the problem still cannot be completely avoided.

9.4.3 Bromination

Because of the two major problems for chlorination, lack of selectivity and multi-substitution, chlorination is not useful as a synthesis method to prepare a specific alkyl halide product. Instead, bromination with Br_2 can be applied for that purpose. The relative lower reactivity of bromine makes it exhibits a much greater selectivity. Bromine is less reactive, means it reactive more slowly, therefore it has chance to differentiate between the different types of hydrogens, and selectively reacts with the most reactive one. The relative reaction rate of bromination for different radical is shown here, and you can see the big difference to that of chlorination:



Figure 9.4e Relative reaction rate of bromination

For bromination, the reactivity difference between different types of position is so high that the reactivity factor become predominant for determining the product. Therefore **bromination usually occurs selectively on the most reactive position** (the position that forms the most stable carbon radical intermediate), and gives one major product exclusively, as the example here for bromination of isobutane.

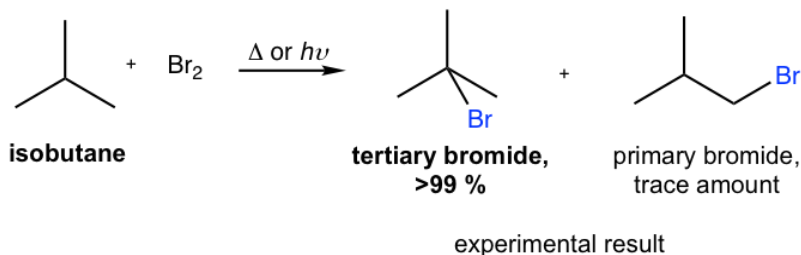

99%) + primary bromide, trace amount” width=“477” height=“153”> Figure 9.4f An example of the bromination of isobutane

As a result, **bromination has the greatest utility synthesis of alkyl halide.**

Exercises 9.2

Show the major bromination product of following reactions.

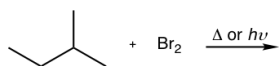

Answers to Practice Questions Chapter 9

This page titled [9.4: Chlorination vs Bromination](#) is shared under a [CC BY-NC-SA 4.0](#) license and was authored, remixed, and/or curated by [Xin Liu](#) (Kwantlen Polytechnic University) .

9.5: Stereochemistry for Halogenation of Alkanes

For substitution reaction in which a stereocenter is generated, the stereochemistry can be explained by the structure feature of radical intermediate.

In the structure of carbon radical, carbon has three bonds and one single electron. Based on VSEPR, there are total four electron groups, radical should be in tetrahedral shape. However, experiment evidence indicate that the geometric shape of most alkyl radical is **trigonal planar** shape, with the carbon in sp^2 hybridization, and there is one single unpaired electron in the unhybridized 2p orbital.

We will take the bromination reaction of (\pm)-3-methylhexane to explain the stereochemistry. The experiment results indicate that the racemic mixture of *R* and *S* 3-bromo-3-methylhexane were obtained with the bromination.

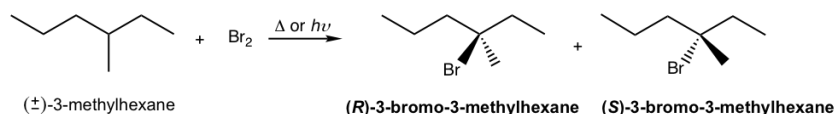

Figure 9.5a Bromination reaction of (\pm)-3-methylhexane

This can be explained by the stereochemistry of the propagation steps in the mechanism. The carbon radical generated in step 1 is in trigonal planar shape as mentioned earlier. When the radical reacts with bromine in step 2, the reaction can occur at either side of the plane. Because both sides are identical, the probability of the reaction by either side is the same, therefore equal amount of the *R*- and *S*- enantiomer are obtained as a racemic mixture.

propagation step 1:



step 2:

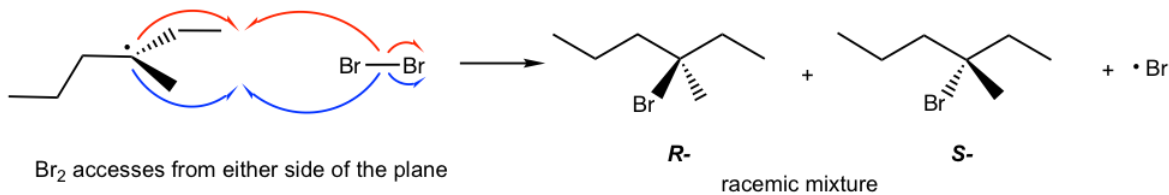
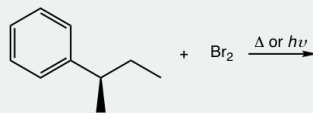

Figure 9.5b Propagation steps

The stereochemistry of the radical substitution is similar to that of S_N1 reaction, because both carbon radical and carbocation are in trigonal planar shape.

Examples

Show the bromination product(s) with stereoisomers when applied.



Solutions:

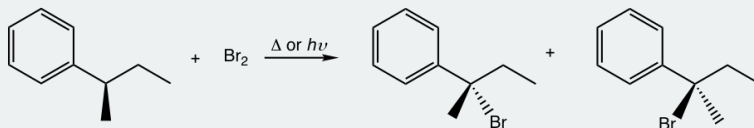

The racemic mixture is obtained.

Exercises 9.3

Show all the mono-chlorination products of butane with any stereoisomers when applied.

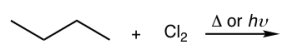
[Answers to Practice Questions Chapter 9](#)

This page titled [9.5: Stereochemistry for Halogenation of Alkanes](#) is shared under a [CC BY-NC-SA 4.0](#) license and was authored, remixed, and/or curated by [Xin Liu \(Kwantlen Polytechnic University\)](#).

9.6: Synthesis of Target Molecules- Introduction of Retrosynthetic Analysis

We have learned three major types of reactions so far, nucleophilic substitution, elimination and halogenation of alkane (radical substitution), now we will see how to put the knowledge of these reactions together for application, that is to design synthesis route for a target (desired) compound from available starting materials.

Building larger, complex organic molecules from smaller, simple molecules is the goal of organic synthesis. Organic synthesis have great importance for many reasons, from testing the newly developed reaction mechanism or method, to replicate the molecules of living nature, and to produce new molecules that have potential applications in energy, material or medicinal fields.

It usually take multiple steps, from several to 20 or more, to synthesize a desired compounds, and therefore it would be challenging to visualize from the start all the steps necessary. The common strategy to design a synthesis is to work **backward**, that is instead of looking at the starting material and deciding how to do the first step, we look at the product and decide how to do the last step. This process is called **retrosynthetic analysis**, the technique applied frequently in organic synthesis. We will introduce the basic ideas of retrosynthetic analysis here, and for practice purpose the starting material is always defined for our examples.

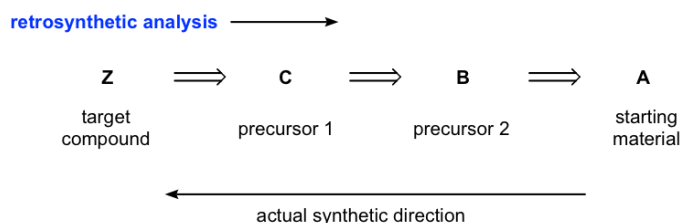
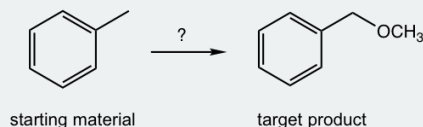

Figure 9.6a Retrosynthetic analysis

Retrosynthetic analysis can usually be shown in the above way, with the open arrows indicate that the analysis is **backward**. We first identify the precursor 1 that could react in one step to make the target compound, then identify the next precursor that could react to give precursor 1, and repeat the process until we reach the starting material. Please note that the analysis is the way to show the “thinking or ideas” for solving the problem, so typically the reagents/conditions required for each step are not specified until the synthesis route is written in the forward direction. Also it is very possible you may come up with multiple routes, with different precursors, then the most efficient synthesis route can be determined by evaluating the possible benefits and disadvantages of each path.

Examples

Design the synthesis route of methoxybenzene starting from toluene.



Approach: The target compound is an ether. We have learned that S_N2 reaction is a reasonable way to introduce different functional groups by applying different nucleophiles (**section 7.3**), that said the reaction between CH_3O^- (nucleophile) and halide gives the desired ether, and the halide can be the “precursor 1”. The halide precursor can then be directly connected with the starting material, toluene, through the halogenation that we just learned in this chapter. This is an easy example that only involve two steps.

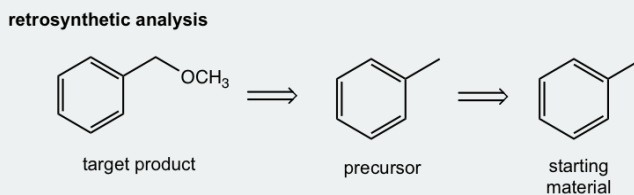

Solutions:

The analysis can then be transferred to the solution of the question by showing the reactions in forward direction and include the reagents/condition for each step.

synthesis

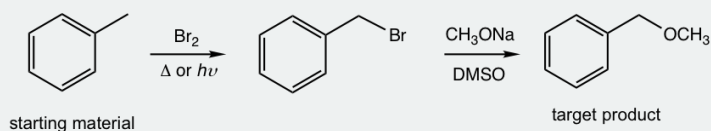

Synthesis route design is a rather challenge topic that need lots practices. In order to do that well, you should be very familiar with all types of reactions in terms of how the functional groups transformed, and what reagents and conditions involved. Sometimes some reaction features, like stereochemistry will be useful as well.

Exercises 9.4 Design the synthesis route.

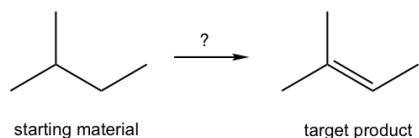

Answers to Practice Questions Chapter 9

This page titled [9.6: Synthesis of Target Molecules- Introduction of Retrosynthetic Analysis](#) is shared under a [CC BY-NC-SA 4.0](#) license and was authored, remixed, and/or curated by [Xin Liu \(Kwantlen Polytechnic University\)](#).

9.7: Answers to Practice Questions Chapter 9

9.1 Predict the percentage yield of each product for monochlorination of isobutane by calculation, and compare your calculated numbers to the experiment results. Are they consistent?



Calculation:

Amount of 1°-chloride: 9 (number of 1°hydrogens) × 1.0 (relative reactivity) = 9.0

Amount of 3°-chloride: 1 (number of 3°hydrogens) × 3.8 (relative reactivity) = 3.8

yield% of 1°-chloride: 8.0/12.8 = 70.3 %

yield% of 3°-chloride 3.8/12.8 = 29.7 %

The calculated values are consistent to the experiment results, not exactly same though.

9.2 Show the major bromination product of following reactions.

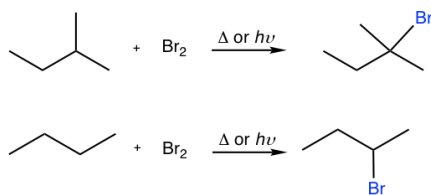

9.3 Show all the mono-chlorination products of butane with any stereoisomers when applied.

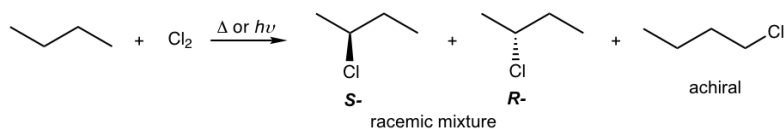

9.4 Design the synthesis route.

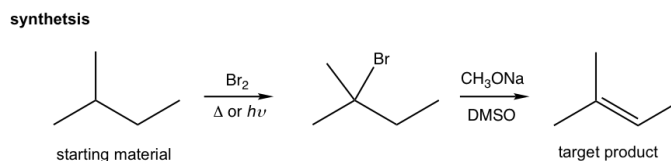

This page titled [9.7: Answers to Practice Questions Chapter 9](#) is shared under a [CC BY-NC-SA 4.0](#) license and was authored, remixed, and/or curated by [Xin Liu \(Kwantlen Polytechnic University\)](#).

CHAPTER OVERVIEW

10: Alkenes and Alkynes

- 10.1: Synthesis of Alkenes
- 10.2: Reactions of Alkenes- Addition of Hydrogen Halide to Alkenes
- 10.3: Reactions of Alkenes- Addition of Water (or Alcohol) to Alkenes
- 10.4: Reactions of Alkenes- Addition of Bromine and Chlorine to Alkenes
- 10.5: Reaction of Alkenes- Hydrogenation
- 10.6: Two Other Hydration Reactions of Alkenes
- 10.7: Oxidation Reactions of Alkenes
- 10.8: Alkynes
- 10.9: Answers to Practice Questions Chapter 10

Thumbnail: Ball-and-stick model of the ethylene (ethene) molecule, C_2H_4 . (Public Domain; Ben Mills via [Wikipedia](#))

This page titled [10: Alkenes and Alkynes](#) is shared under a [CC BY-NC-SA 4.0](#) license and was authored, remixed, and/or curated by [Xin Liu](#) (Kwantlen Polytechnic University).

10.1: Synthesis of Alkenes

10.1.1 Dehydrohalogenation of Alkyl Halide

The E2 elimination reaction of alkyl halide is one of the most useful method for synthesizing alkene.

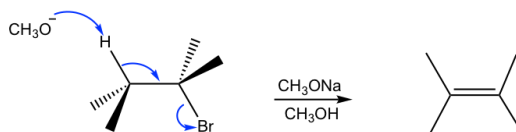

E2 elimination of alkyl halide to synthesize alkene

Figure 10.1a E2 elimination of alkyl halide to synthesize alkene

Lots discussions have been given about the mechanism and stereochemistry of E2 reaction in **Chapter 8**. Here are a few practical hints about making use of E2 reaction to prepare alkene as the desired product:

- Choose a secondary or tertiary substrate if possible, since they prefer E2.
- If primary substrate is necessary, choose a bulky base such as $t\text{-BuO}^-$, to avoid the competition of substitution reaction. As mentioned early (**section 8.4**) that primary substrate undergoes S_N2 reaction with small species like OH^- , that is also a good nucleophile.
- High concentration of a strong base at elevated temperature favor E2 reaction.
- Keep in mind that small base produces Zaitsev's product (more substituted alkene), while bulky base produces Hofmann product (less substituted alkene).

10.1.2 Dehydration of Alcohol

Other than alkyl halides, alcohols can also be the substrates for elimination to produce alkenes. Most alcohols undergo elimination by losing the OH group and an H atom from an adjacent carbon. Since a water molecule is eliminated for the overall reaction, the reaction is also called dehydration. Two dehydration reactions are shown below for synthesizing alkene from alcohol. Dehydration of an alcohol requires a strong acid with heat. Concentrated sulfuric acid (H_2SO_4) or phosphoric acid (H_3PO_4) are the most commonly used acids in the lab.

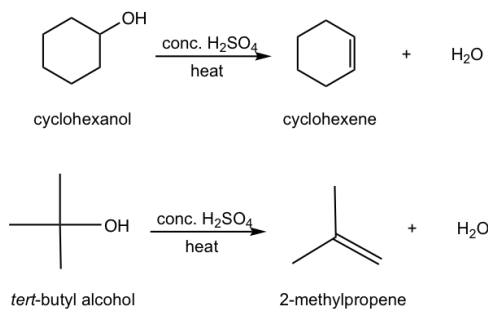
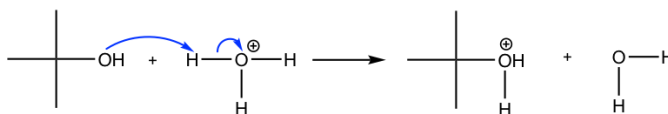

Figure 10.1b Examples of dehydration reactions

Understanding the dehydration reaction mechanism would be helpful for us to apply the method effectively. Let's take the dehydration of *tert*-butyl alcohol as an example.

Mechanism: Dehydration of *tert*-butyl alcohol

Step 1: protonation of OH group



Step 2: water leaves as leaving group, carbocation intermediate formed

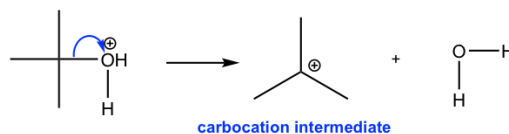

Step 3: β -hydrogen removed to produce alkene

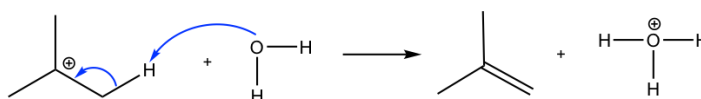

Figure 10.1b The mechanism for dehydration of *tert*-butyl alcohol

The elimination mechanism involves the carbocation intermediate, so it is essentially an E1 mechanism. However, not a typical E1, since it starts with the protonation step. We have learned in substitution reaction chapter (**section 7.6**) that OH group is a poor leaving group, so it never leaves. However, with the presence of strong acid (H_3O^+ , H_2SO_4 , etc), OH group is protonated by acid and therefore converted to the good leaving group H_2O . The same concepts apply here in elimination as well. Step 1 in the mechanism is the acid-base reaction for the purpose to convert poor leaving group OH to good leaving group H_2O . Step 2 and 3 are typical steps for an E1 mechanism. The overall dehydration reaction can be regarded as the E1 reaction of a protonated alcohol.

For E1 mechanism, the rate-determining step is the formation of carbocation, so the relative stability of carbocation defines the relative reactivity of alcohol towards E1 dehydration. As you can predict that the trend is:



Another observation in dehydration reaction is that rearrangement occurs. This makes sense because the mechanism involves the formation of carbocation. We have learned the concept in **section 7.6**, that a carbocation will rearrange if the rearrangement produces a more stable carbocation. An example of dehydration with rearrangement is given below:

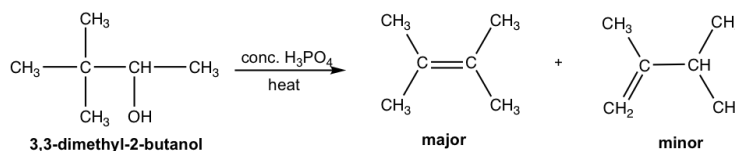
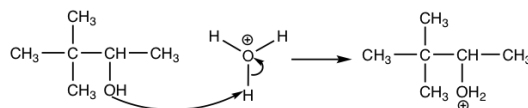

Figure 10.1c Example of dehydration with rearrangement

For the dehydration of 3,3-dimethyl-2-butanol, two alkenes are obtained with 2,3-dimethyl-2-butene as the major product. However, both products have a different carbon skeleton compared to that of the reactant. This is due to the rearrangement of the carbocation intermediate, which is shown explicitly in the mechanism below.

Mechanism: Dehydration of 3,3-dimethyl-2-butanol

Step 1:



Step 2:

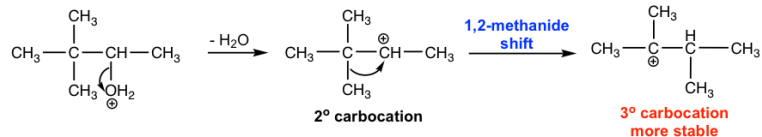

Step 3:

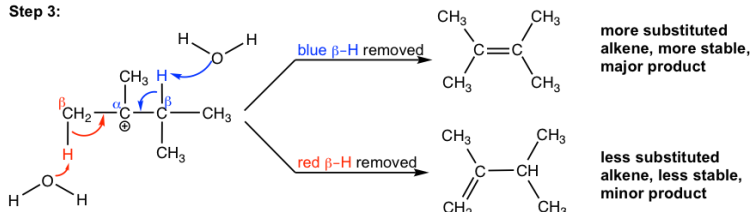

Figure 10.1d Dehydration of 3,3-dimethyl-2-butanol

In step 2 of the mechanism, the initially formed secondary carbocation undergoes rearrangement, 1,2-methanide shift, to produce the more stable tertiary carbocation.

In step 3, there are two β -hydrogens available in the tertiary carbocation for removal. The more substituted alkene, which is more stable, is the major product.

Primary Alcohol Elimination

The primary alcohol can also undergo dehydration, however through an E2 mechanism because the primary carbocations are too unstable to be formed. The first step of the mechanism still involves the protonation of OH group though, to convert the poor leaving group to a good leaving group. The second step is the actual E2 of the protonated primary alcohol.

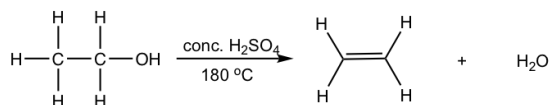
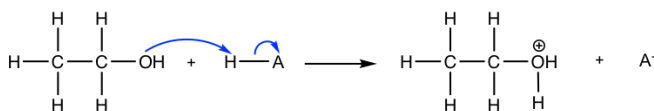

Figure 10.1e Example of a Primary Alcohol Elimination

Mechanism: Dehydration of ethanol

Step 1: protonation of OH group



Step 2: E2, base removes a hydrogen from the β -carbonyd, double bond forms, and water leaves.

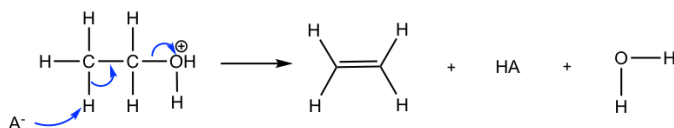

Figure 10.1f Dehydration of ethanol

This page titled [10.1: Synthesis of Alkenes](#) is shared under a [CC BY-NC-SA 4.0](#) license and was authored, remixed, and/or curated by [Xin Liu \(Kwantlen Polytechnic University\)](#).

10.2: Reactions of Alkenes- Addition of Hydrogen Halide to Alkenes

Alkenes undergo a large variety of reactions. At first glance, these reactions appear to be quite different, however detailed studies indicated that the different mechanism all share some common features. The double bond is the reactivity center of alkene, this is mainly because of the relatively loosely held π electrons of the double bond. The π bond is formed by side-by-side overlapping, the relative weak overlapping mode, so π bond is weak and exhibits high reactivity. The π electrons also make the double bond carbons electron-rich, and have the tendency to be attracted to an electrophile. The high reactivity make alkenes an important type of organic compounds, and they can be used to the synthesis a wide variety of other compounds, such as halide, alcohol, ethers, alkanes.

The most common type of reaction for alkene is the **addition reaction** to C=C double bond. In addition reaction, a small molecule is added to multiple bond and one π bond is converted to two σ bonds (unsaturation degree decreases) as a result of addition. Addition reaction is the opposite process to elimination.

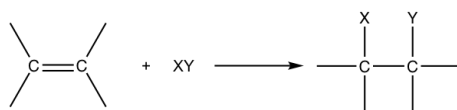

General equation for addition reaction of alkene

Figure 10.2a General equation for addition reaction of alkene

The addition reactions can generally be categorized depends on what small molecule added, our following discussions will also be based that.

10.2.1 Addition of Hydrogen Halide to Alkenes

The addition reaction of a hydrogen halide to an alkene produces an alkyl halide as product. For examples:

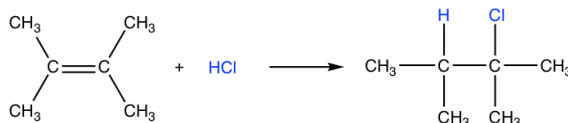

Figure 10.2b Addition reaction of a hydrogen halide to an alkene

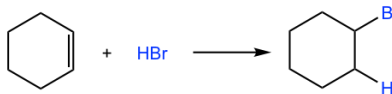

Figure 10.2c Addition reaction of a hydrogen halide to an alkene

In above reactions, the alkenes are in symmetric structures, that means it does not matter which carbon bonded with hydrogen and which carbon bonded the halogen, the same product will be obtained in either way.

For the alkene that does not have the symmetric structure, the double bond carbons have different substituents, then the question of which carbon get the hydrogen is very critical. For the example of following reaction, two possible products could be produced, 2-bromo-2-methylpropane and 1-bromo-2-methylpropane, which one is actually formed? Or are both formed?

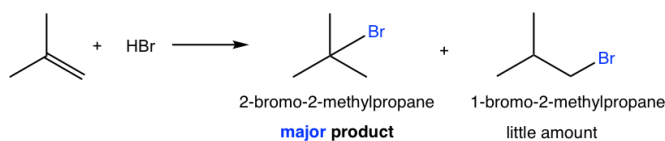

Figure 10.2d Which product is formed?

It turns out that 2-bromo-2-methylpropane is the main product for the reaction. To explain and understand the outcome of the reaction, we need to look at the mechanism of the reaction as we always do.

The mechanism of the addition reaction involves two steps (shown below). In first step, the π electrons of the alkene act as nucleophile and are attracted to the partially positively charged hydrogen (electrophile) of HBr. As the π electrons of the alkenes moving toward the hydrogen, the H-Br bond breaks, with Br moves away with the bonding electrons, and a new σ bond formed between one double bond carbon and hydrogen. A carbocation and a bromide, Br^- , are formed this step.

In the second step, the bromide, Br^- , reacts with the positively charged carbocation to give the final product. This step is sort of similar to the second step of $\text{S}_{\text{N}}1$ reaction, in which a nucleophile reacts with electrophile (carbocation).

Mechanism: Electrophilic addition of HBr to 2-methylpropene

Step 1: Electrophilic attack of HBr to the alkene, carbocation intermediate formed (slow, rate-determining step).

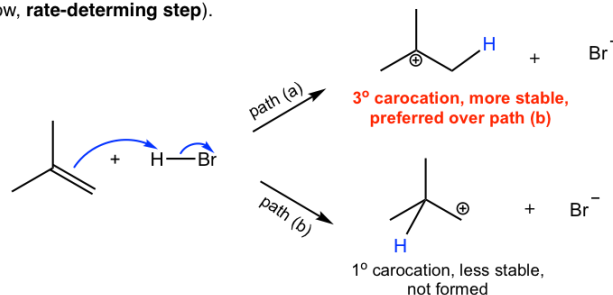

Step 2: Halide anion reacts with the carbocation (fast).

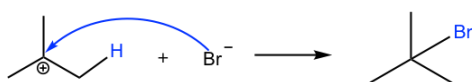

Figure 10.2e Mechanism: Electrophilic addition of HBr to 2-methylpropene

When the new bond formed between double bond carbon and hydrogen in first step, the hydrogen could possibly be bonded with either carbon, as shown in path (a) and (b), and the carbocations with different structure will be produced. It is obvious to tell that the tertiary carbocation formed in path (a) is much more stable than the primary carbocation in path (b), and will be produced preferably. The tertiary carbocation is then attacked by the Br^- in the second step, that produces the product 2-bromo-2-methylpropane. It is the stability difference between two carbocations in the first step that accounts the selective formation of 2-bromo-2-methylpropane of the overall reaction.

Because the first step of the above reaction is the addition of an electrophile (H^+) to the alkene, the reaction is called an **electrophilic addition reaction**. Electrophilic addition reaction is a characteristic type of reaction of alkenes, several other addition reactions we will see later also belong to this category.

The two possible products of this reaction are constitutional isomers to each other. For the reaction in which two or more constitutional isomers could be obtained as products, but one of them predominates, the reaction is said to be a **regioselective reaction**. *Regio* comes from Latin word *regionem* that means direction. The regioselectivity trend of the electrophilic addition of HX to alkenes had been summarized as **Markovnikov's rule** by Russian chemist Vladimir Markovnikov. One way to state **Markovnikov's rule** is that **in the addition of HX to an alkene, the hydrogen atom adds to the double bond carbon that has greater number of hydrogen atoms**.

The underlying reasoning for Markovnikov's rule is the stability of carbocation intermediate that involved in reaction mechanism. It seems easy for you to just memorize the rule or just memorize the fact that 2-bromo-2-methylpropane is the product for above reaction, without understanding why. However, you will notice soon that your memorization will be overwhelmed and mixed up with many more reactions coming up. The proper way to study organic reactions is to learn and understand the mechanism, unify the principles of reactions based on mechanism. The mastery of the contents will much easier and a lot more fun in this way, rather than trying to memorize tons of reactions.

Exercises 10.1

Show structure of the major product for following addition reactions.

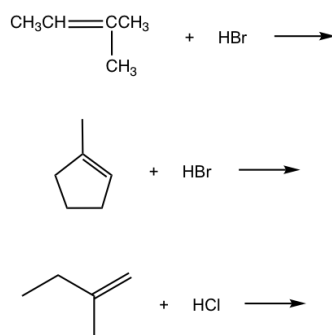

Answers to Practice Questions Chapter 10

Exercises 10.2

For the addition of HBr to 3-methyl-1-butene, two products were observed. Show the reaction mechanism to explain the formation of both products.

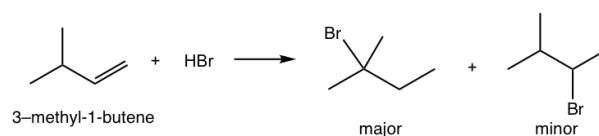

10.2.2 Radical Addition of HBr to Alkenes

In last section we learned that the electrophilic addition of HX to alkene gives addition products that follow Markovnikov's rule. Here we will learn that the hydrobromide, HBr, can also add to alkene in a way that gives anti-Markovnikov product.

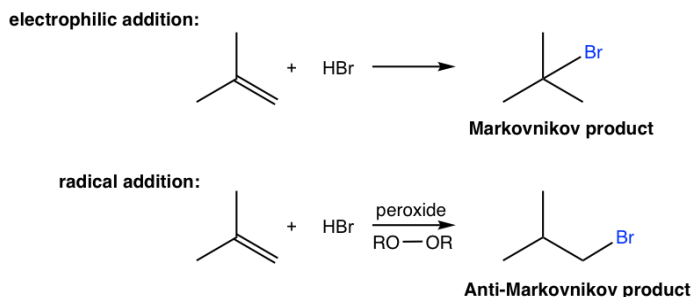

Figure 10.2f Electrophilic addition produces Markovnikov product & radical addition produces Anti-Markovnikov product

The anti-Markovnikov product are obtained through different mechanism, that is the radical mechanism. To initiate radical mechanism, peroxide **must be involved** in order to generate the radical in the initiation step of the mechanism. The O-O bond of peroxide is weak (with bond energy of about 150 kJ/mol), and it undergoes the homolytic cleavage readily with heat to produce alkoxy radicals. The peroxide therefore acts as **radical initiator** by generating radicals, and the addition is called **radical addition**. The detailed radical addition mechanism of the above addition of HBr to 2-methylpropene is given here.

Radical Addition Mechanism:

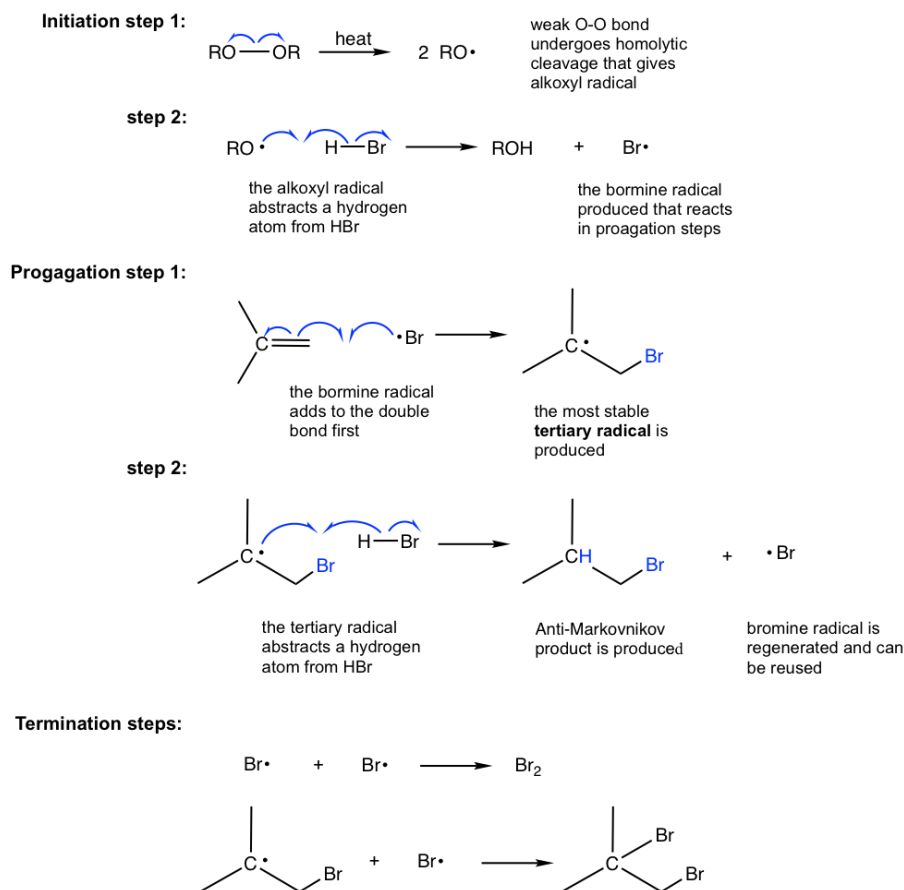

Figure 10.2g Radical Addition Mechanism:

The initiation involves two steps for the radical addition mechanism. The alkoxy radical generated in step 1 reacts with H-Br to generate bromine radical, $\text{Br}\cdot$, that reacts with alkene to initiate the chain reaction in propagation steps. It shown clearly in the propagation steps that the order of the addition is reversed in radical addition comparing to that of electrophilic addition. Specifically, the bromine radical (Br) is added to the double bond first followed by the abstraction of hydrogen atom (H), therefore the anti-Markovnikov product is produced as a result.

One more note is that **only HBr proceed with radical addition in the presence of peroxide**, not HCl or HI.

This page titled [10.2: Reactions of Alkenes- Addition of Hydrogen Halide to Alkenes](#) is shared under a [CC BY-NC-SA 4.0](#) license and was authored, remixed, and/or curated by [Xin Liu \(Kwantlen Polytechnic University\)](#).

10.3: Reactions of Alkenes- Addition of Water (or Alcohol) to Alkenes

Addition of Water to Alkenes (Hydration of Alkenes)

An alkene does not react with pure water, since water is not acidic enough to allow the hydrogen to act as an electrophile to start a reaction. However, with the presence of small amount of an acid, the reaction does occur with a water molecule added to the double bond of alkene, and the product is an alcohol. This is the acid-catalyzed addition reaction of water to alkene (also called hydration), and this reaction has great utility in large-scale industrial production of certain low-molecular-weight alcohols.

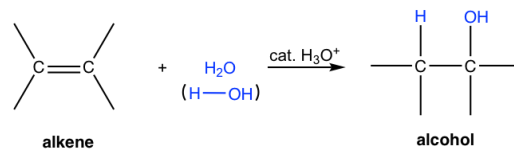

Figure 10.3a Hydration Reaction

The acid most commonly applied to catalyze this reaction is dilute aqueous solution of sulfuric acid (H_2SO_4). Sulfuric acid dissociates completely in aqueous solution and the hydronium ion (H_3O^+) generated participates in the reaction. Strong organic acid, tosyl acid (TsOH), is used sometimes as well.

The mechanism for acid-catalyzed hydration of alkene is essentially the same as the mechanism for the addition of hydrogen halide, HX , to alkenes, and the reaction therefore follows Markovnikov's rule as well in terms of regioselectivity. The hydration of 1-methylcyclohexene and the reaction mechanism are shown below.

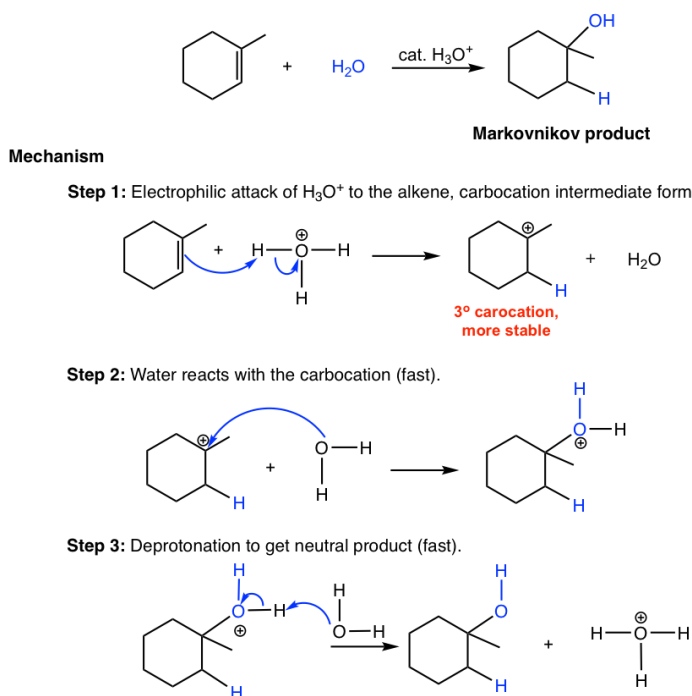

Figure 10.3b Mechanism for acid-catalyzed hydration of alkene

Since water molecule can be regarded as $\text{H}-\text{OH}$, so the regioselectivity of alcohol product that follows Markovnikov's rule means the hydrogen atom connects to the double bond carbon that has more hydrogen atoms, and OH group adds to the carbon that has less hydrogen atoms. This can be explained again by the formation of more stable carbocation in the first step of the mechanism. The acidic hydronium ion (H_3O^+) is regenerated in the last deprotonation step, so only a small amount of acid is required to initiate the reaction, the acid therefore is a catalyst.

Comparing the hydration reaction of alkene to the dehydration reaction of alcohol in section 10.1.2, you would recognize that they are reverse reactions, one is addition and the other is elimination. To produce alcohol from alkene via hydration, water should be in excess to ensure the reaction goes to completion. While to prepare alkene from alcohol through dehydration, high concentration of

acid with elevated temperature favor the elimination process and the product can be removed by distillation as they formed to push the equilibrium to alkene side.

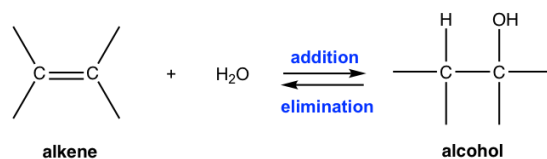

Figure 10.3c Hydration reaction of alkene vs. dehydration reaction of alcohol

Addition of Alcohol to Alkenes

With the presence of acid, an alcohol can be added to the alkene in the same way that water does, and ether formed as product. For example:

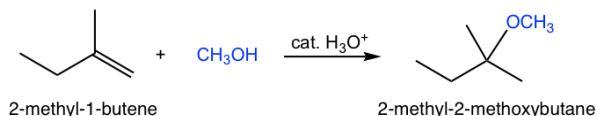

Figure 10.3d Example of addition of Alcohol to Alkenes

Examples: Show the mechanism for above addition reaction of methanol to 2-methyl-1-butene.

Refer to the hydration mechanism.

Solutions:

Mechanism: addition of methanol to 2-methyl-1-butene

Step 1: Electrophilic attack of H_3O^+ to the alkene, carbocation intermediate formed

Step 2: Methanol reacts with the carbocation

Step 3: Deprotonation to get neutral product

Mechanism: addition of methanol to 2-methyl-1-butene

Step 1: Electrophilic attack of H_3O^+ to the alkene, carbocation intermediate formed

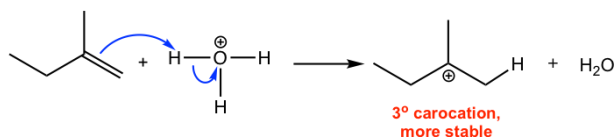

Step 2: Methanol reacts with the carbocation

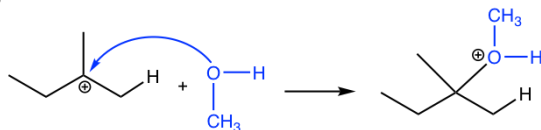

Step 3: Deprotonation to get neutral product

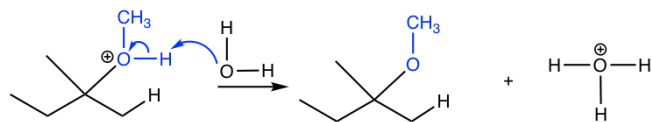

Note: Please keep in mind that for the reaction that involves carbocation intermediate, the rearrangement of carbocation is always an option. Therefore the addition of water/alcohol to alkenes may involve carbocation rearrangement if possible.

Exercises 10.3

Show major product(s) for the following reactions.

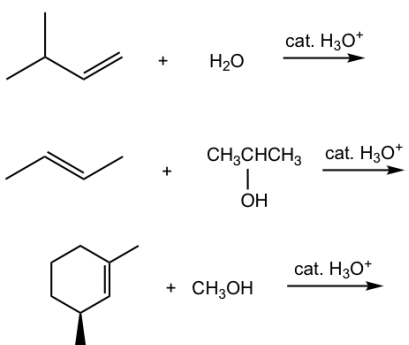

Answers to Practice Questions Chapter 10

This page titled [10.3: Reactions of Alkenes- Addition of Water \(or Alcohol\) to Alkenes](#) is shared under a [CC BY-NC-SA 4.0](#) license and was authored, remixed, and/or curated by [Xin Liu \(Kwantlen Polytechnic University\)](#).

10.4: Reactions of Alkenes- Addition of Bromine and Chlorine to Alkenes

Addition reaction also occur easily between halogens (Br_2 and Cl_2) and alkenes. In the presence of aprotic solvent, the product is a vicinal dihalide, as shown here for the addition of chlorine to propene.

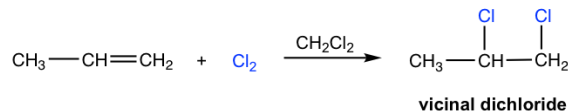
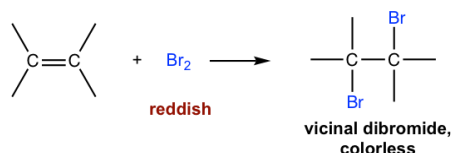

Figure 10.4a Addition reaction

The reaction between C=C double bond and bromine (Br_2) can be used as a test for the presence of alkene in an unknown sample. The bromine reagent is in reddish color, and the product vicinal dibromide is colorless. When bromine is added to the sample, if the reddish color disappears, that means the sample does contain an alkene. The addition reaction occurs to get reddish bromine consumed and colorless product formed, so color fades off.



Mechanism for the Addition of Halogen to Alkenes

The products for addition of halogen to alkenes seems straightforward, with each halogen added to each double bond carbon. However, the addition proceeds with unique stereochemistry feature that need special attention. It turns out that the halogen atoms are added via **anti addition** to the double bond, as examples shown here:

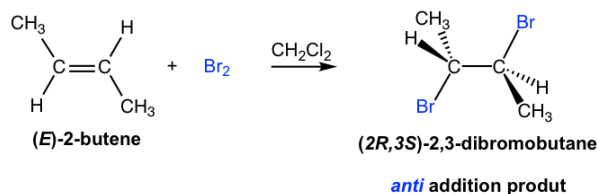
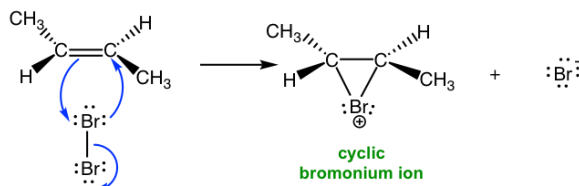

Figure 10.4b Anti addition product

The mechanism that accounts for the anti addition of halogen involves the electron pairs transferred in a way that is different to what we are familiar with, and the formation of the cyclic halonium ion intermediate. We will take the addition of bromine to (E)-2-butene as example to explain the mechanism.

Mechanism: addition of Br_2 to E-2-butene

Step 1: formation of bromonium ion



Step 2: Br^- attacks from the direction that is anti to bromonium ion

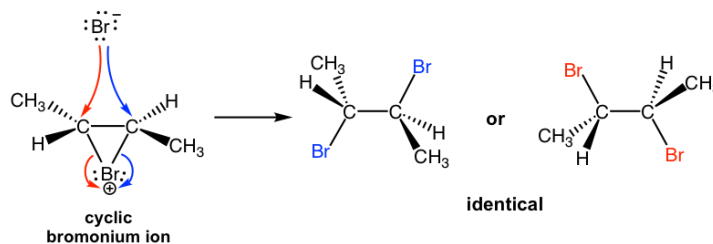
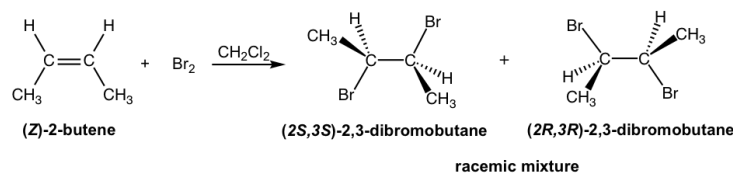

Figure 10.4c Mechanism: addition of Br_2 to E-2-butene

When Br_2 molecule approaching alkene in the first step, the electron density of the π bond in alkene repels electron density in the bromine, polarizing the bromine molecule and make the bromine atom that is closer to the double bond electrophilic. The alkene donate a pair of π electrons to the closer bromine, causing the displacement of the bromine atom that is further away. The lone pair on the closer bromine atom then acts as nucleophile to attack the other sp^2 carbon. Thus, the same bromine atom is both electrophile and the nucleophile, and two single bonds are formed between the two sp^2 carbons and the closer bromine that gives the cyclic bromonium ion intermediate.

In the second step, the nucleophilic bromide, Br^- (generated in step 1), attacks the carbon of the cyclic intermediate. Since the bottom side of the intermediate is blocked by the ring, the Br^- can only attack from the top side, that results in the **anti** position of the two Br in the product. The attack is similar to $\text{S}_{\text{N}}2$ reaction and cause the ring to open and the formation of vicinal dibromide. For the above example, the two carbons in the bromonium ion intermediate are in same chemical environment, so they both have the same chance to be attacked by Br^- , as shown in blue and red arrows. The two attacks result in the same product, the meso compound (2*R*,3*S*)-2,3-dibromobutane, in this reaction.

Next, let's exam the addition of bromine to (**Z**)-2-butene. As you may expect, the reaction goes through the same mechanism that involves the cyclic bromonium ion intermediate, however the products have different stereochemistry features.



Mechanism: addition of Br_2 to (*Z*)-2-butene

Step 1: formation of bromonium ion

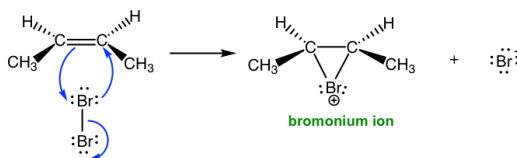

Step 2: attack of Br^- to bromonium ion from anti direction

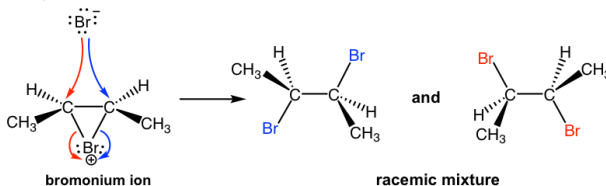

Figure 10.4d Mechanism: addition of Br_2 to (*Z*)-2-butene

In the addition of Br_2 to (**Z**)-2-butene, the attack of Br^- to either carbon in bromonium ion by following blue or red arrow results in different enantiomer (step 2 in above mechanism). Since both carbons have the same chance to be attacked, so the product is the 50:50 racemic mixture of the two enantiomer.

Starting from the two different diastereomers, (**E**)-2-butene and (**Z**)-2-butene, the addition reaction produces different stereoisomers. The addition of (**E**)-2-butene gives one product, the meso compound (2*R*,3*S*)-2,3-dibromobutane, while the addition of (**Z**)-2-butene produces the racemic mixture of two enantiomers, (2*S*,3*S*)-2,3-dibromobutane and (2*R*,3*R*)-2,3-dibromobutane. Such reaction, the one where a particular stereoisomer of the starting material yields a specific stereoisomer of the product is called **stereospecific reaction**. The anti addition of a halogen to an alkene is an example of a **stereospecific reaction**.

Examples

Show the product of following addition.

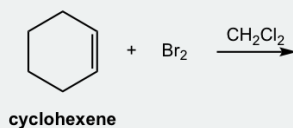

Solutions:

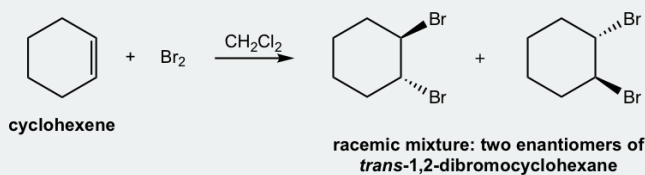

The formation of the racemic mixture product can be explained by the mechanism:

Mechanism

Step 1:

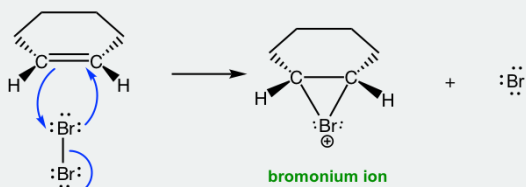

Step 2:

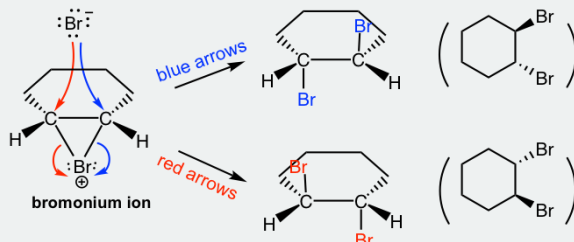

Formation of Halohydrin

If water is used as a solvent in the reaction, rather than CH₂Cl₂, then water takes in part of the reaction and acts as nucleophile to attack the cyclic halonium intermediate in the second step. The major product of the addition will be a vicinal halohydrin as a result. A vicinal halohydrin is the compound that contains a halogen and an OH group on two adjacent carbons.

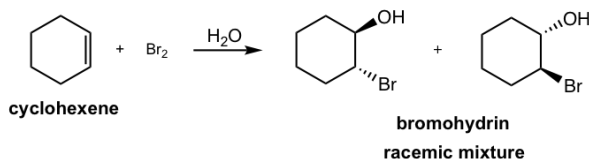

Figure 10.4e Formation of Halohydrin

Mechanism: reaction of bromine water with cyclohexene

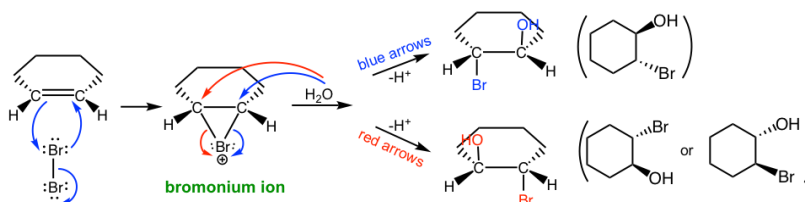
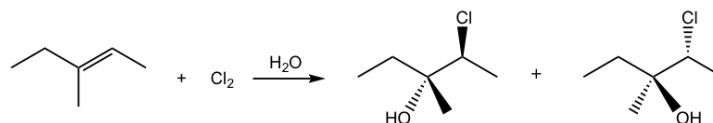

Figure 10.4f Mechanism: reaction of bromine water with cyclohexene

In second step of the mechanism, both H₂O (solvent) and Br⁻ (produced in the first step) are nucleophiles and have chance to react with the cyclic bromonium ion. However since H₂O is the solvent, its concentration is much higher than that of Br⁻, so the major products come from the attack of H₂O.

This reaction is still the stereospecific reaction in which the **anti** addition occurs, that the halogen and OH group are in anti position. For above example, the addition of bromine water to cyclohexene, the racemic mixture with both enantiomers are obtained.

If the alkene is not in symmetric structure, it is observed that the addition shows the regioselectivity as well, specifically the halogen adds on the carbon atom with greater number of hydrogen atoms, and OH group ends up on the double bond carbon with less amount of hydrogen atoms. How to explain this?



This is due to the difference between the two double bond carbons in the cyclic intermediate. When nucleophile water attacks, the C-Br bond start to breaking and the carbon atom has partial positive charges. The carbon atom with two substituents bears more positive charges and it resembles the more stable tertiary carbocation, and the other carbon atom with one substituent shows secondary carbocation character. As a result, the attack to the carbon with more tertiary carbocation character it is more preferably.

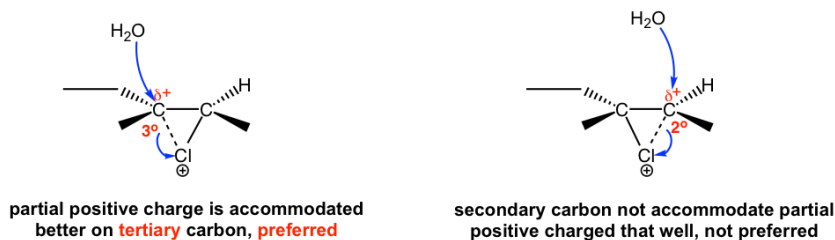
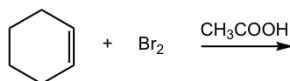
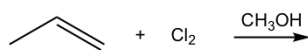

Figure 10.4f tertiary carbon vs. secondary carbon

Exercises 10.4

Show major product(s) of the following reactions:



Answers to Practice Questions Chapter 10

This page titled [10.4: Reactions of Alkenes- Addition of Bromine and Chlorine to Alkenes](#) is shared under a [CC BY-NC-SA 4.0](#) license and was authored, remixed, and/or curated by [Xin Liu \(Kwantlen Polytechnic University\)](#) .

10.5: Reaction of Alkenes- Hydrogenation

When alkenes react with hydrogen gas in the presence of a variety of metal catalysts, a hydrogen molecule will be added to the double bond in the way that each carbon atom bonded with one hydrogen atom, such addition reaction is called **hydrogenation**.

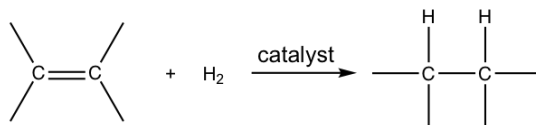

Catalysts are must-have for hydrogenation, so the reaction can also be called **catalytic hydrogenation**. The commonly applied metal catalysts involve palladium and platinum. Palladium, which is used as a powder absorbed on charcoal to maximize the surface area, is the most common catalyst that is referred to as palladium on charcoal (Pd/charcoal). Platinum, which is used usually as oxide PtO₂, is also employed frequently and referred to as Adams catalyst. These metal catalysts are **not** soluble in the reaction mixture and therefore are described as heterogeneous catalysts. The heterogeneous catalyst can be easily filtrated out of the reaction mixture after reaction, and then be recycled and reused.

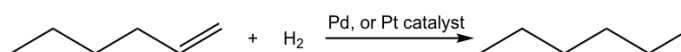

The hydrogenation reaction does not take place without catalyst because of the enormous activation energy. The catalysts lower down the activation energy by weakening the H-H bond, and make the reaction feasible at room temperature. The details of the mechanism of catalytical hydrogenation are not completely clear. What was understood was that hydrogen gas is adsorbed on the surface of the metal, and the alkene also complexes with the metal by overlapping its π orbitals with vacant orbitals of the metal. The reaction occur on the surface of the metal catalyst, with both hydrogen atoms added from the same side of the alkene, to give alkane as the product that diffuses away from the metal surface. This mode of addition that the atoms added from the same side of the alkene is called the **syn addition**.

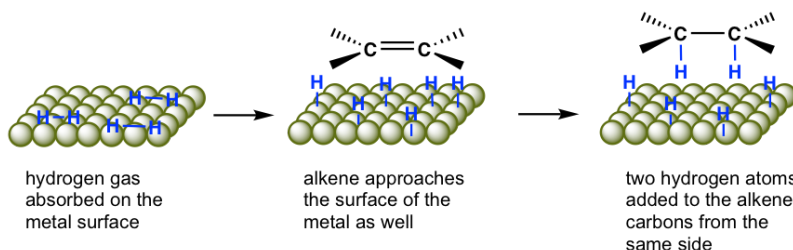

simplified diagram for catalytic hydrogenation of alkene

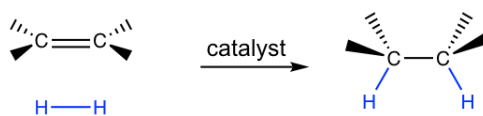

catalytic hydrogenation: **syn addition**

Example:

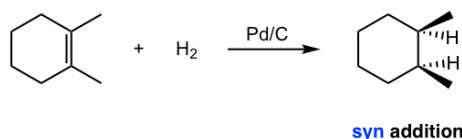

This page titled 10.5: Reaction of Alkenes- Hydrogenation is shared under a [CC BY-NC-SA 4.0](https://creativecommons.org/licenses/by-nc-sa/4.0/) license and was authored, remixed, and/or curated by [Xin Liu \(Kwantlen Polytechnic University\)](https://www.kwantlen.ca/).

10.6: Two Other Hydration Reactions of Alkenes

As we learned in section 10.2.2, the acid-catalyzed hydration (addition of water) to alkene produces alcohol that follow Markovnikov's regioselectivity. Here we will investigate two other methods for hydration of alkene, via different reaction conditions and mechanism, and produce either Markovnikov or anti-Markovnikov alcohol product respectively.

10.6.1 Oxymercuration–Demercuration of Alkenes The oxymercuration–demercuration of alkenes provides an alternative way to synthesize Markovnikov's alcohol from alkene. It is a fast reaction with lots application in laboratories, and the yield is usually greater than 90%. Comparing to acid-catalyzed hydration, the benefits of oxymercuration–demercuration are: no strong acids required and no carbocation rearrangements involved. The only reason that limits the wide application of this method is the environment concern since mercury (Hg) waste produced.

Oxymercuration–demercuration is a two-step procedure, as shown explicitly below:

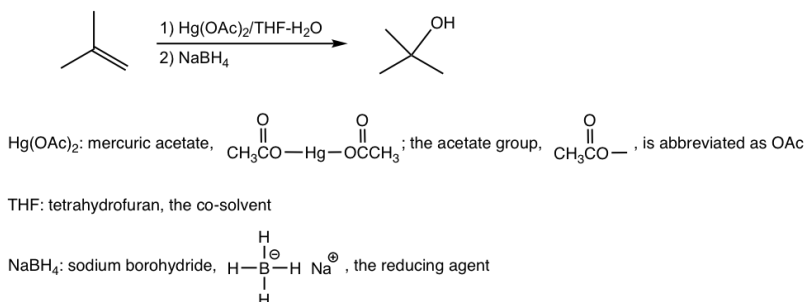

Step 1 Oxymercuration: mercuric acetate and water add to the double bond

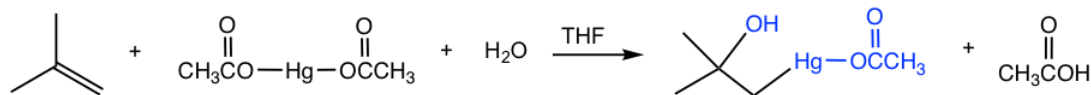

Step 2 Demercuration: the mercuric group is reduced and replaced with hydrogen

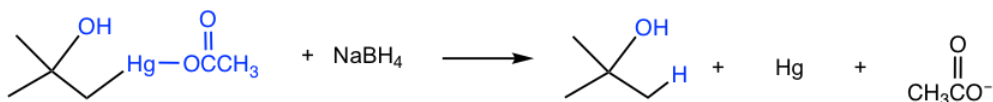

Figure 10.6a 1. Oxymercuration & 2. Demercuration

The mechanism in the oxymercuration step involves a mercury acting as a reagent attacking the alkene double bond to form a cyclic *mercurinium ion* intermediate. Because no carbocation intermediate involved, rearrangements are not observed in such reaction. Then a water molecule attacks the *most substituted* carbon to open the mercurinium ion bridge, followed by proton transfer to solvent water molecule. For the same reasoning that water molecule attacks the more substituted carbon of the cyclic halonium ion in halohydrin formation (section 10.2.4), the water molecule in this mechanism also attacks the more substituted carbon preferentially, as the partial positive charge is better accommodated on a tertiary carbon than on a primary carbon (if attack occurs on the other carbon).

Mechanism of Oxymercuration:

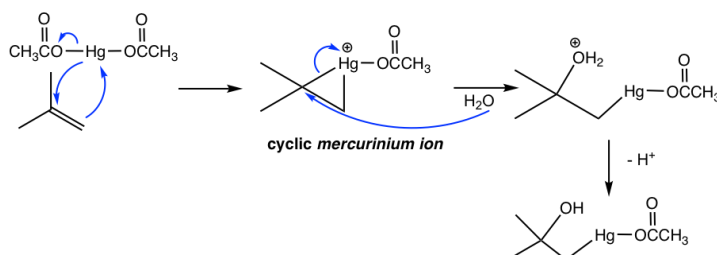

Figure 10.6b Mechanism of Oxymercuration

The organomercury intermediate is then reduced by sodium borohydride, the mechanism for this final step is beyond the scope of our discussions here. Notice that the overall oxymercuration–demercuration mechanism follows Markovnikov's rule with the OH

group is attached to the most substituted carbon and the hydrogen atom adds to the less substituted carbon.

10.6.2 Hydroboration –Oxidation of Alkenes

Hydroboration-oxidation is another method to convert alkene to alcohol, however, in **anti-Markovnikov** regioselectivity, that is OH is bonded to the carbon with greater number of hydrogens and hydrogen atom bonded to the carbon with less hydrogens.

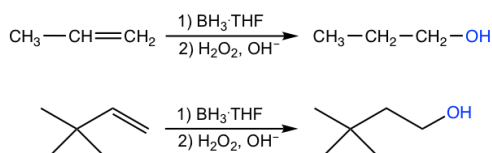

Figure 10.6c Hydroboration-Oxidation of Alkenes

The overall reaction is also a two-step process:

- First step is hydroboration, that is the addition of boron atom and hydrogen atom to the alkene.
- Second step is oxidation and hydrolysis of the alkylborane formed in step 1, to produce alcohol.

The borane reagent used in the first step is usually available as the solution containing $\text{BH}_3 \cdot \text{THF}$ complex. Borane, BH_3 , is an electron-deficient species because the boron atom has incomplete octet with only six electrons. When BH_3 is introduced to THF, they react to form a Lewis acid-Lewis base adduct (Chapter 3.??), which is more stable and relatively easy to be handled and stored. The solution containing $\text{BH}_3 \cdot \text{THF}$ is still rather sensitive and must be used in an inert atmosphere (nitrogen or argon) and with care.

Because of the incomplete octet of the boron atom in BH_3 , it is a good electrophile that reacts with alkene. The mechanism of the hydroboration step is illustrated below with propene as the example.

Mechanism of Hydroboration

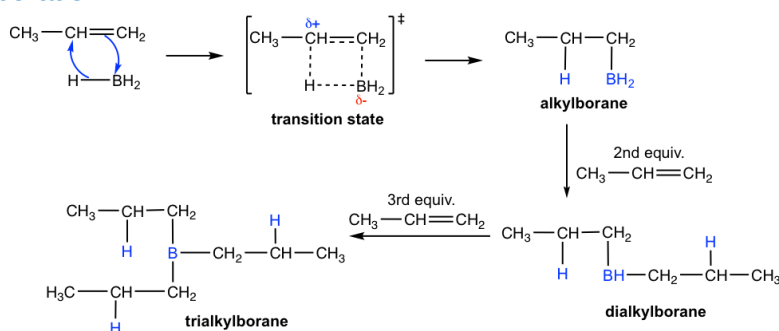

Figure 10.6d Mechanism of Hydroboration

When a terminal alkene, for example propene, is treated with $\text{BH}_3 \cdot \text{THF}$, the BH_3 molecule adds successively to the $\text{C}=\text{C}$ double bond of three alkene molecules to form an trialkylborane. In each addition step, the boron atom becomes attached to the *less substituted* double bond carbon, and a hydrogen atom transferred from the BH_3 to the more substituted carbon. In the second step (oxidation and hydrolysis) of the whole process, the borane is oxidized and hydrolyzed to OH group. So **the regioselectivity of the hydroboration step defines the anti-Markovnikov regioselectivity of the overall reaction.**

Such regioselectivity of the hydroboration step can be explained by both electronic and steric effects. In terms of steric factor, the boron-containing group is more bulky than hydrogen atom, so they can approach the less substituted carbon more easily. The electronic effect lies in the transition state structure for the formation of alkylborane. As shown above, the π electrons from the double bond is donated to the π orbital of boron and a four-atom ringcyclic transition state is approached. In the transition state, electrons shift in the direction of the boron atom and away from the carbon that is not connected to the boron. This make the carbon not connected to the boron bears a partial positive charge, that is better accommodated on the more substituted carbon. As a result the electronic effect also favors the addition of boron on the less substituted carbon.

Stereochemistry of Hydroboration

Hydroboration-oxidation takes place with **syn** stereochemistry, that the OH group and the hydrogen atom add to the same side of the double bond, as shown in the following example.

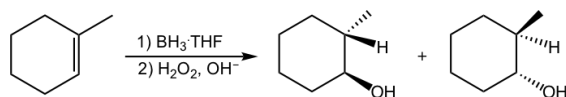

Figure 10.6e Stereochemistry of Hydroboration

This can be explained by the mechanism of the hydroboration step. The four-membered ring transition state requires that the boron atom and the hydrogen atom approach to the same surface of the alkene double bond, so they are added in the **syn** position to the double bond. Since the boron part is converted to OH group in the second step, that results in the syn addition of OH and H in the product.

Oxidation and Hydrolysis of trialkylboranes

With the hydroboration reaction is over, the trialkylboranes are usually *not* isolated, they are oxidized and hydrolyzed with the addition of hydrogen peroxide (H_2O_2) in basic aqueous solution. The mechanism for the oxidation and hydrolysis of trialkylboranes is rather complicated and could be an optional topic, the net result is the boron that initially bonded on the carbon is replaced by the hydroxy OH group.

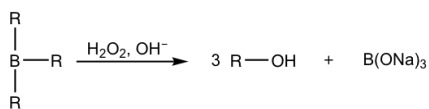

Figure 10.6f Oxidation and Hydrolysis of trialkylboranes

Mechanism: Oxidation and Hydrolysis of trialkylboranes

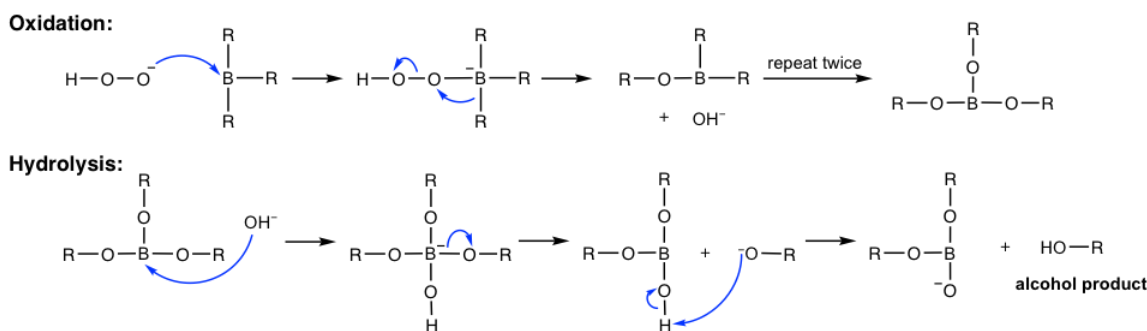

Figure 10.6g Mechanism: Oxidation and Hydrolysis of trialkylboranes

Summary: Hydration Methods of Alkene

Overall there are three methods for converting alkene to alcohol via addition, they are acid-catalyzed hydration, oxymercuration-demercuration and hydroboration-oxidation. Each method has its own character with benefit and disadvantage. The proper method could be picked up based on the need.

	Acid-catalyzed hydration	Oxymercuration-demercuration	Hydroboration-oxidation
Reaction Conditions	cat. H^+/H_2O	1) $Hg(OAc)_2/THF \cdot H_2O$ 2) $NaBH_4$	1) $BH_3 \cdot THF$ 2) $NaBH_4$
Regioselectivity	Markovnikov	Markovnikov	Anti-Markovnikov
Stereochemistry	Not controlled	Not controlled	syn-addition

Rearrangement	Yes	No	No
----------------------	-----	----	----

This page titled [10.6: Two Other Hydration Reactions of Alkenes](#) is shared under a [CC BY-NC-SA 4.0](#) license and was authored, remixed, and/or curated by [Xin Liu \(Kwantlen Polytechnic University\)](#).

10.7: Oxidation Reactions of Alkenes

Alkenes undergo a number of reactions in which the C=C double bond is oxidized. For organic compounds, a conventional way to tell whether the oxidation or reduction occur is to check the number of C–O bonds or the C–H bonds. An **oxidation reaction** increase the number of C–O bonds or decrease the number of C–H bonds. On the other side a **reduction reaction** increase the number of C–H bonds or decrease the number of C–O bonds. The relative oxidation state of some common organic functional groups are listed here based on the trend.

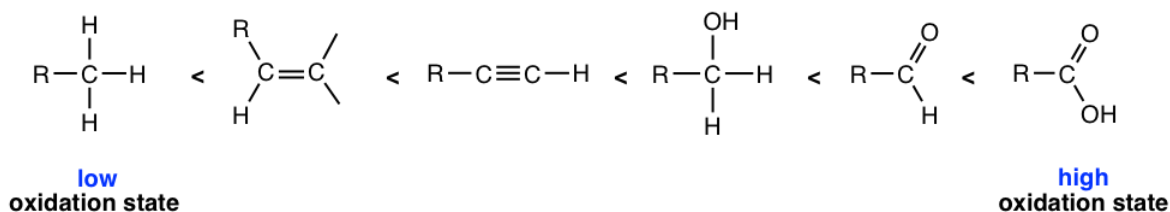

Figure 10.7a The relative oxidation state of some common organic functional groups

10.7.1 Syn 1,2-Dihydroxylation

1,2-Dihydroxylation, the conversion of the C=C double bond to 1,2-diol, is an oxidative addition reaction of alkene. Osmium tetroxide (OsO₄) is a widely used oxidizing agent for such purpose. Potassium permanganate can be used as well, although further oxidation is prone to occur to cleave the diol because it is a stronger oxidizing agent (**10.7.2**).

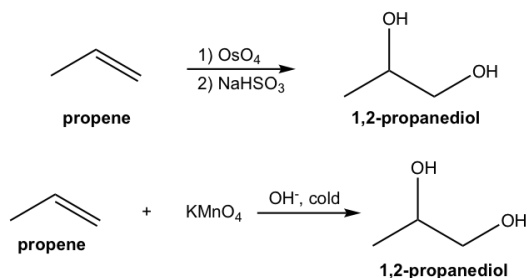

Figure 10.7b Example of 1,2-Dihydroxylation

The traditional method of 1,2-dihydroxylation with osmium tetroxide is a **two-step procedure**. Osmium tetroxide first reacts with alkene to form a cyclic osmate ester intermediate and this cyclic intermediate involves the **syn addition** of OsO₄ to the double bond. The cleavage of the O–Os bond of the intermediate then takes place in the second step with reducing agent NaHSO₃, without modifying the stereochemistry of the C–O bond. The diol formed therefore has the **syn** stereochemistry property.

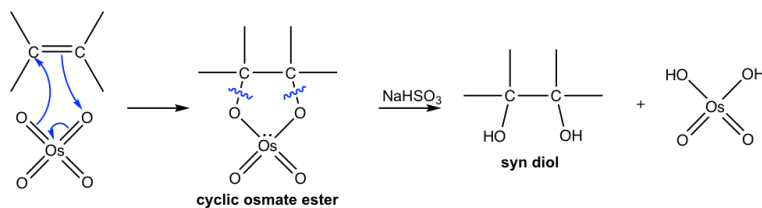
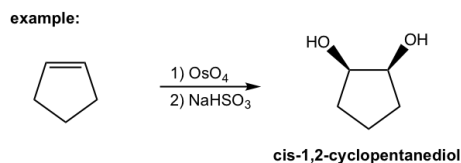

Figure 10.7c 1,2-dihydroxylation mechanism



Catalytic OsO₄ 1,2-Dihydroxylation

The 1,2-dihydroxylation with osmium tetroxide is an effective reaction that is used very often in the labs for the preparation of diol from alkene. However, this method has major drawbacks because osmium tetroxide is a highly toxic, volatile and expensive reagent. Improved methods have been developed that allow only a catalytic amount of OsO₄ being used in conjunction with a co-oxidant in a stoichiometric amount. *N*-methylmorpholine *N*-oxide (NMO) is one of the most commonly employed co-oxidants. In such

condition, osmium compounds are re-oxidized by NMO and can be reused to react with more alkenes, so only small molar percentage of OsO_4 is necessary in the reaction mixture. The reaction proceeds smoothly with syn diols produced in good yield.

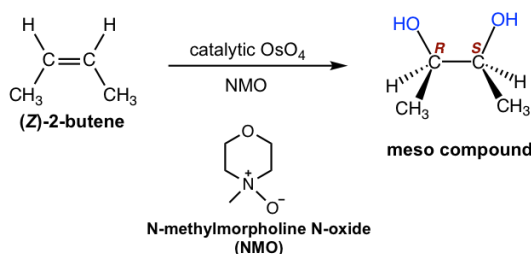
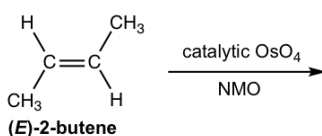

Figure 10.7d Example of a Catalytic OsO_4 1,2-Dihydroxylation

In terms of the stereochemistry of the product, although the syn addition could occur on either side of the alkene plane, that gives the same product which is the meso compound. This can be identified by either looking for the plane of symmetry of the product, or by assigning the absolute configuration on the chirality centers. Review the stereochemistry knowledge.

Examples Show product of following reaction:



Solution:

The syn addition occurs on either side of the alkene plane, so both enantiomers are obtained with same amount as racemic mixture.

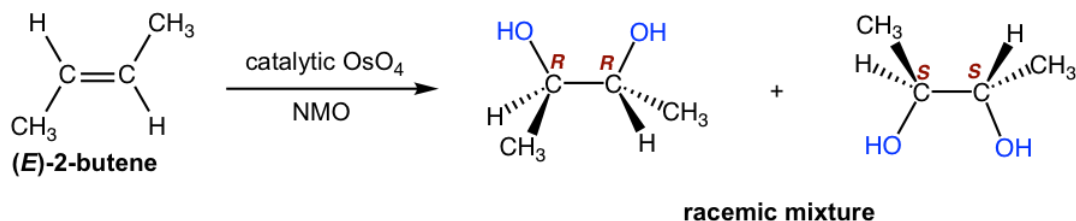

10.7.2 Oxidative Cleavage of Alkenes

Cleavage with Ozone

With stronger oxidizing agent being applied, the $\text{C}=\text{C}$ double bond of alkenes can be oxidatively cleaved, and the alkene molecule is cleaved to smaller molecules.

The most effective way for cleaving alkene is to use ozone, O_3 , by a two-step process. Alkene is first reacted with ozone at very low temperature (-78°C) and then treated with dimethyl sulfide, $(\text{CH}_3)_2\text{S}$, (or $\text{Zn}/\text{CH}_3\text{COOH}$) to give the cleavage products. The whole process is called **ozonolysis**.

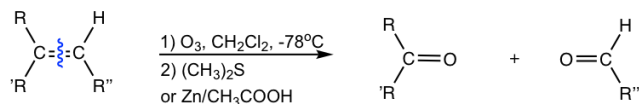

Figure 10.7e The process of Cleavage with Ozone

Ozonolysis results in the cleavage of the double bond, and each double bond carbon get bonded to an oxygen atom with a new double bond. The products of ozonolysis are aldehyde(s) and/or ketone(s), and the exact structures of the products depends on the structure of the initial alkene:

- Disubstituted alkene carbons are oxidatively cleaved to ketone;
- Monosubstituted alkene carbons are oxidatively cleaved to aldehyde;
- Unsubstituted alkene carbons are oxidatively cleaved to formaldehyde (HCHO).

Examples

Show ozonolysis products of following reactions:

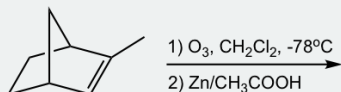
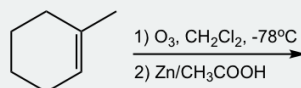
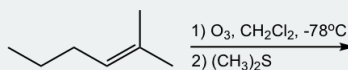

Hint: To figure out the structure of ozonolysis product(s), “cut” the double bond, then “add” a “=O” (double bonded oxygen) to each carbon.

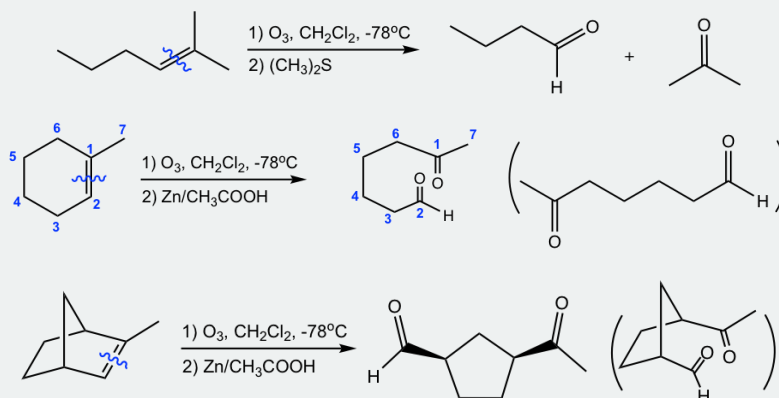

As shown with above examples, ozonolysis reaction is useful as a synthetic tool for certain aldehyde and ketone. Meanwhile, it is also a method for determining the position of double bonds in an alkene by working backward from the structure of the products.

Examples

Determine the structure of the alkene:

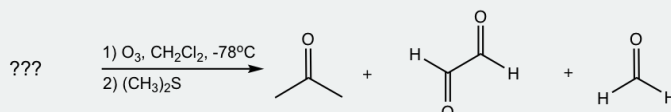

Approach: To determine the structure of initial alkene, we can work backwards by connecting two C=O bonds in the products together. The two C=O bonds are “connected” to give a C=C bond with all oxygen atoms “removed”. In this example, the two blue C=O bonds gives the blue C=C bond, and the two red C=O bonds gives the red C=C bond.

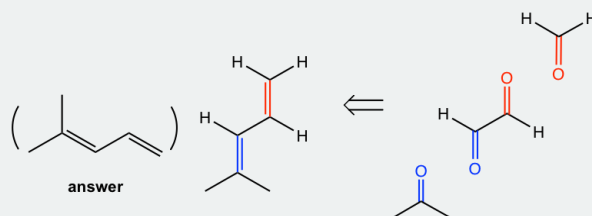

Mechanism for Ozonolysis

The hints mentioned earlier is to help us solving the problems with ozonolysis reaction, not the reaction mechanism. The mechanism of ozonolysis reaction is rather complicated that involves the formation of initial cyclic ozonide that decompose to

fragments, and the fragment recombine to form a new cyclic ozonide, which is reduced to give products.

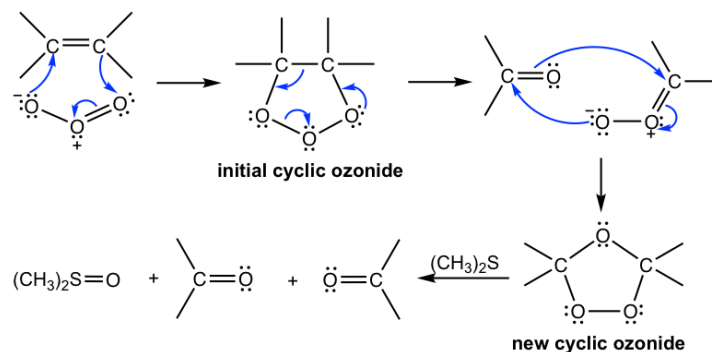

Figure 10.7f Mechanism for Ozonolysis

Cleavage with Potassium Permanganate KMnO₄

Potassium permanganate, **KMnO₄**, is another oxidizing agent that cleaves the C=C double bond of an alkene. Under hot basic condition, the oxidative cleavage products of alkenes could involve ketone, salt of carboxylic acid or carbon dioxide depends on the different substituent patterns on the alkene:

- Disubstituted alkene carbons are oxidatively cleaved to ketone;
- Monosubstituted alkene carbons are oxidatively cleaved to the carboxylic acid (in salt format);
- Unsubstituted alkene carbons are oxidatively cleaved to CO₂ and H₂O.

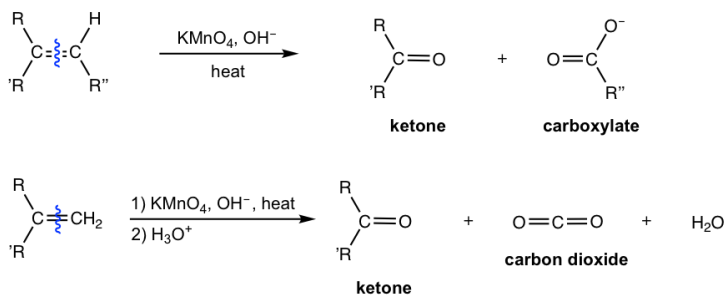

Figure 10.7g Cleavage with Potassium Permanganate KMnO₄

KMnO₄ is a stronger oxidizing agent that further oxidize the initial cleavage products, therefore aldehyde is further oxidized to carboxylic acid (in salt format under basic condition). For terminal unsubstituted alkene carbons, the initial product is HCHO, which is then further oxidized to carboxylate CO₃²⁻ in basic condition. Acidification of CO₃²⁻ produces H₂CO₃ that decomposes to CO₂ and H₂O. Because of over oxidation, KMnO₄ is not the useful reagent for the synthesis of aldehyde/ketone from alkenes.

This page titled [10.7: Oxidation Reactions of Alkenes](#) is shared under a [CC BY-NC-SA 4.0](#) license and was authored, remixed, and/or curated by [Xin Liu \(Kwantlen Polytechnic University\)](#).

10.8: Alkynes

Alkyne is the hydrocarbon that contain C≡C triple bond. In this section, we will explore the methods for the synthesis of alkyne and the chemical reactions of alkynes.

10.8.1 Acidity of Terminal Alkynes and Related Reactions

In the discussions of acids and bases (**Chapter 3**), we have learned that the hydrogen atom bonded to the terminal alkyne carbon shows higher acidity than the hydrogen atoms bonded to the carbons of an alkene or alkane, and the pK_a value of the terminal alkyne hydrogen is about 25.

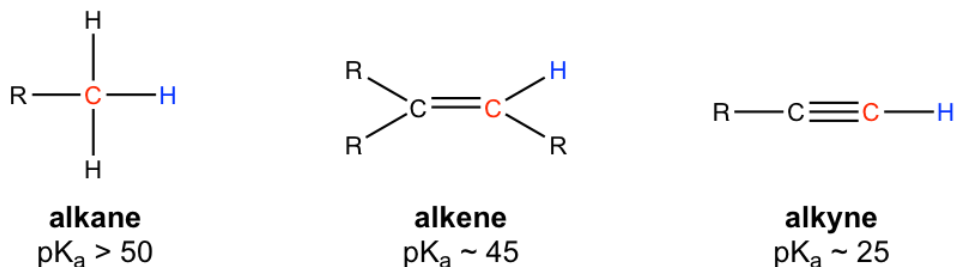

Figure 10.8a Acidity of Terminal Alkynes

Because of the relative high acidity, the terminal alkynes can be deprotonated by appropriate strong bases, such as NaH, NaNH₂.

deprotonation of terminal alkyne:

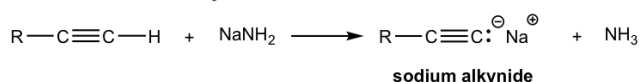

Figure 10.8b Deprotonation of terminal alkyne

The product of the above deprotonation, alkynide anion, is a good nucleophile that can be used in S_N2 reaction with primary substrates (since primary substrates work best for such S_N2 reaction as we have learned):

S_N2 reaction:

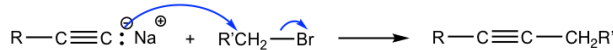

Figure 10.8c S_N2 reaction

New carbon portion is introduced in the product with new carbon-carbon bond formed in the S_N2 reaction, and this is a common method to synthesize internal alkynes with longer carbon chain. A specific example for the synthesis of 2-methyl-3-hexyne from 3-methyl-1-butyne is given here:

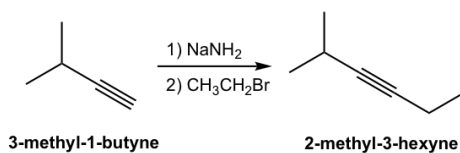
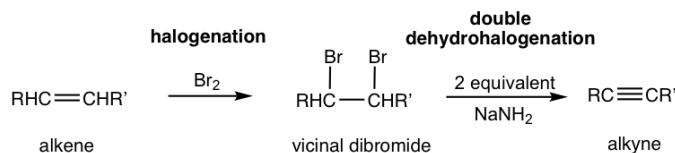

Figure 10.8d Synthesis of 2-methyl-3-hexyne

10.8.2 Synthesis of Alkynes by Elimination

The method in **10.4.1** applies to the synthesis of alkyne with certain structure. The more general way to synthesize alkyne is via the elimination reaction of vicinal dihalides. Recall that vicinal dihalides are the halogenation products of alkenes (section **10.4**). The vicinal dihalide can then be subjected to a double dehydrohalogenation reaction with a strong base to produce an alkyne.



synthesis of internal alkyne by dehydrohalogenation

Figure 10.8e Synthesis of internal alkyne by dehydrohalogenation

The dehydrohalogenation occurs twice, in two steps, the first product is a haloalkene, and the second product is the alkyne. Amide, usually NaNH_2 , is a base that is strong enough to cause both reactions carried out consecutively in the same mixture. Two molar equivalents of sodium amide per mole of the dihalide are required to ensure the elimination occur two times.

Mechanism: Double dehydrohalogenation of vicinal dibromide

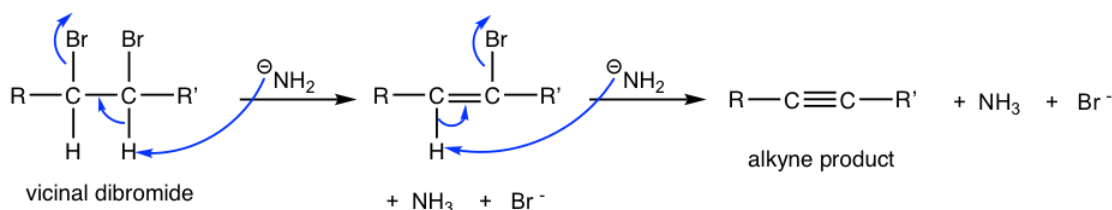
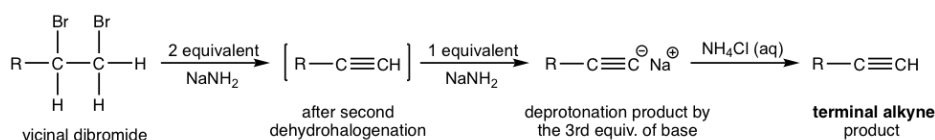

Figure 10.8f Mechanism: Double dehydrohalogenation

If a terminal alkyne is the desired product, then three molar equivalents of base are required. The terminal alkyne produced after double dehydrohalogenation is deprotonated by sodium amide, the third mole of base is to ensure the deprotonation occurs completely and all the terminal alkyne converted to the salt format. The salt of alkynide was then treated with ammonium chloride (or water, as source of proton) to produce terminal alkyne as the final desired product.



synthesis of terminal alkyne

Figure 10.8g Synthesis of terminal alkyne

Examples

Design the synthesis route of 1-butyne from 1-butene.

Approach:

Use retro-synthetic analysis:

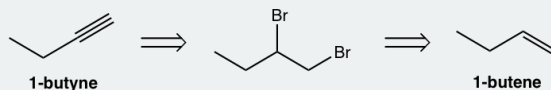

That analysis can be translated to the step-by-step synthesis as:

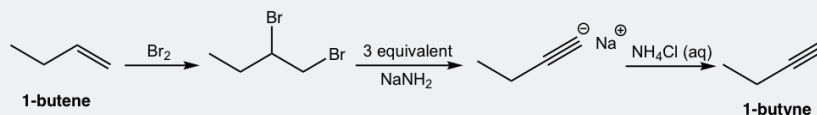

Solution: (show the steps together in the proper order, without showing intermediates for each step)

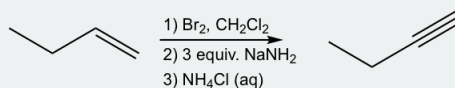

10.8.3 Reactions of Alkynes

Hydrogenation of Alkynes

The catalytic hydrogenation applied to the π bonds of $\text{C}\equiv\text{C}$ triple bonds as well. Depending on the conditions and catalysts employed, one or two molar equivalents of hydrogen will be added to a triple bond and alkene or alkane produced as the product respectively.

When platinum or palladium catalysts applied, the final product of the hydrogenation is an alkane with sufficient hydrogen provided. The initial product is an alkene, that undergoes the reaction successively to give alkane as the final product.

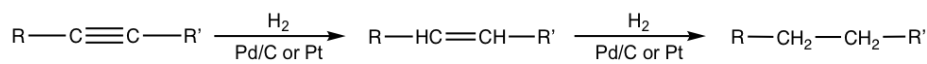

Figure 10.8h Hydrogenation

With certain catalyst used, the hydrogenation of alkyne can be stopped at the alkene stage. The most commonly employed catalyst is the Lindlar catalyst. Lindlar catalyst is prepared by precipitating palladium on calcium carbonate and then treating it with lead (II) acetate and quinoline. The special treatment modifies the surface of the palladium metal by partially deactivating it, and making it more effective at catalyzing the hydrogenation to a triple bond rather than to a double bond.

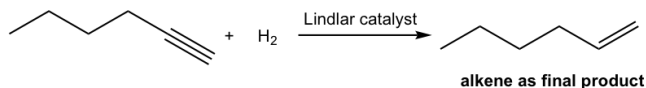

Figure 10.8h Lindlar catalyst

The mechanism for the catalytic hydrogenation of alkyne is almost the same as that of alkene (10.5). Since both hydrogen atoms are delivered from the surface of the catalyst, they are delivered to the same side of the triple bond, therefore the **syn** addition occurs. So the hydrogenation of an internal alkyne produces *cis*-alkene with the Lindlar catalyst.

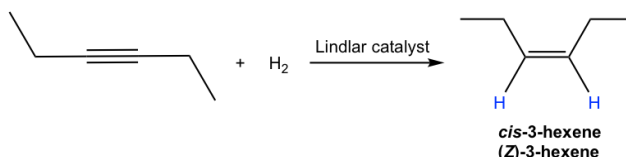

Figure 10.8i Hydrogenation of an internal alkyne produces *cis*-alkene with the Lindlar catalyst.

Internal alkyne can be converted into *trans*-alkene using sodium (or lithium) in liquid ammonia. The mechanism for this reaction involves successive single electron transfers from the metal (sodium or lithium) and proton transfers from ammonia, with radical intermediates. The sodium metal (or lithium) reacts more rapidly with triple bond than double bond, so the reaction stops at the alkene stage. Low temperature (-78 °C) is necessary to keep ammonia at the liquid state.

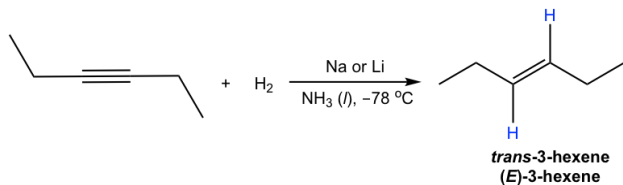

Figure 10.8j Internal alkyne converted to *trans*-alkene using sodium (or lithium) in liquid ammonia.

The *trans*-vinylic anion is formed preferentially because of the higher stability with two R groups farther apart. Protonation of the *trans*-vinylic anion leads to the *trans*-alkene.

Mechanism: Hydrogenation (Reduction) of Alkyne by Metal

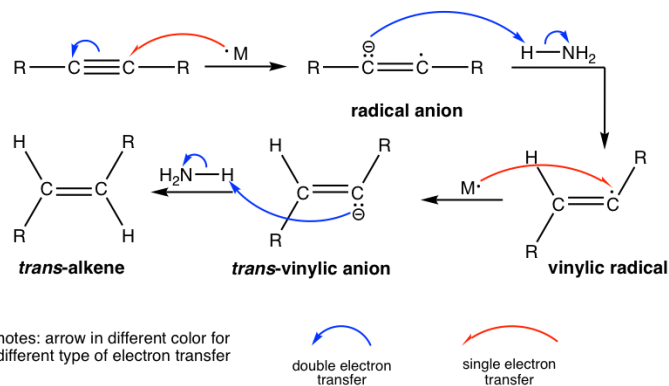

Figure 10.8k Mechanism: Hydrogenation (Reduction) of Alkyne by Metal

Hydrohalogenation of Alkynes

An alkyne is an electron-rich molecule with high density of pi electrons, therefore it is a good nucleophile that reacts readily with electrophiles. Thus alkynes, like alkenes, also undergo electrophilic addition with hydrogen halide.

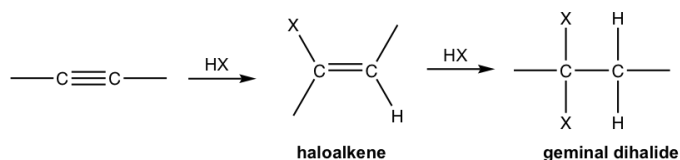

Figure 10.8l Haloalkene and geminal dihalide

- Alkyne reacts with one mole of HX to form haloalkene, and with two moles of HX to form geminal dihalides, the dihalide with both halogen attached to the same carbon. “Geminal” comes from *geminus* in Latin, that means “twin”.
- Both addition follow Markovnikov’s rule in terms of regioselectivity.

If one molar equivalent of HX available, the addition can be stopped at the first addition to haloalkene. The halo-substituted alkene is less reactive than alkyne for electrophilic addition because a halogen substituent withdraws electrons inductively, therefore decreasing the nucleophilicity of the double bond.

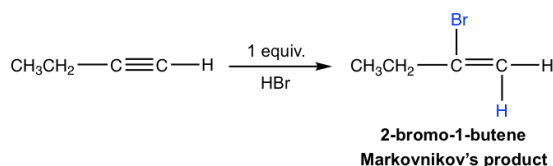

Figure 10.8m 2-bromo-1-butene Markovnikov’s product

The mechanism for the electrophilic addition to alkyne is rather similar to the addition of alkene, with protonation as the first step. For terminal alkyne, if the protonation occurs on different triple bond carbon, the primary or secondary vinylic cation intermediate will formed. The higher stability of the secondary vinylic cation leading to the Markovnikov’s regioselectivity, that the hydrogen atom attached to the carbon that has the greater number of hydrogen atoms.

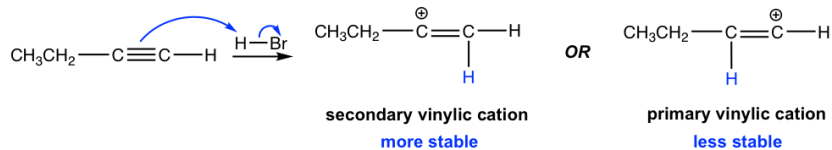

Figure 10.8n Secondary and Primary vinylic cation

If excess hydro halide is present, the addition to alkyne occur twice to give geminal halide that follow the Markovnikov’s regioselectivity.

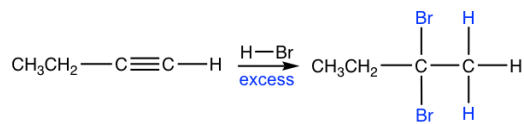

Figure 10.8o Excess hydro halide

Hydration of Alkynes

Alkynes also undergo the acid-catalyzed addition of water (hydration), similar to alkenes. As a result, the H added to one triple bond carbon and OH added to the other triple bond carbon, and the product formed is called an enol (“en” comes from “ene” that means double bond, “ol” means OH group). An **enol** is a compound with a carbon-carbon double bond and an OH group connected on one of the double bond carbon.

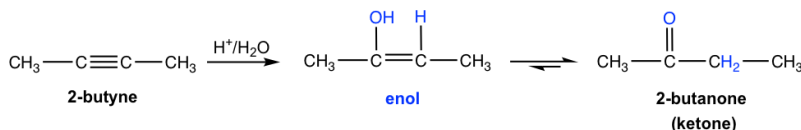

Figure 10.8p Hydration of Alkyne

Enol is a very unstable compound, it immediately undergoes rearrangement to give more stable carbonyl compound, aldehyde or ketone. The structure of a carbonyl compound and an enol differ in the location of the double bond and a hydrogen atom, and they are called **tautomers**. The interconversion between the tautomers is called **tautomerization**. The mechanism is not covered. Enol always undergoes tautomerization rapidly because of the high stability of carbonyl compound, as shown in the general way below.

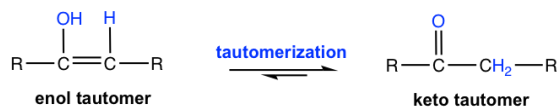

Figure 10.8q Tautomerization

For symmetrical internal alkyne that has the same group attached to each of the triple bond (sp) carbon, the addition of water forms a single ketone as a product. As in the early example that 2-butanone is produced from the hydration of 2-butyne.

For unsymmetrical internal alkyne with different groups on each of the triple bond carbon, the mixture of two ketones are formed because the initial addition of the proton can occur on either of the sp carbons. The hydration of 2-pentyne is shown here that produce the mixture of 2-pentanone and 3-pentanone as product.

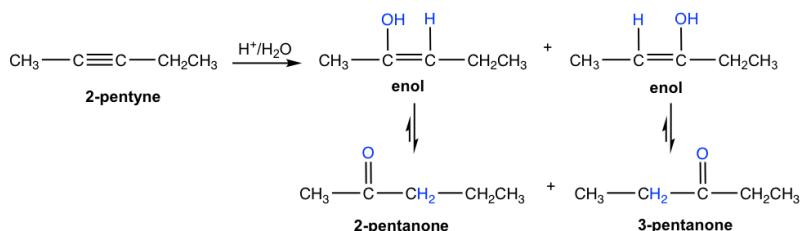

Figure 10.8r Hydration of 2-pentyne

Terminal alkynes are not as reactive as internal alkynes towards the hydration. The addition of water to a terminal alkyne will occur if mercuric ion (Hg^{2+}) present as a catalyst. The enol formed from the addition follows the Markovnikov's rule with the hydrogen atom attached to the terminal carbon, and a methyl ketone (the ketone with a methyl group connected on one side of the C=O bond) is the final product after tautomerization.

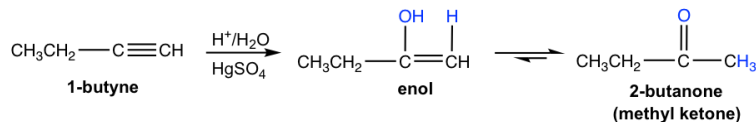

Figure 10.8s Mercuric ion as a catalyst

Hydroboration-Oxidation of Alkynes:

Hydroboration-oxidation also applies to alkyne in the similar way as to alkene. The two-step process results in the enol, that goes through tautomerization to give carbonyl compound.

Meanwhile, the addition of borane to a terminal alkyne shows the same regioselectivity as observed in borane addition to an alkene. That is boron adds preferentially to the terminal triple bond (sp) carbon (the carbon with more hydrogen atom), or the terminal carbon with less substituents. After oxidation, the boron-containing group is converted to the OH group, so the enol is produced in the anti-Markovnikov way, with OH connected on the terminal carbon. The tautomerization of such enol generates aldehyde as the final product.

Comparing the two hydration methods of alkyne, hydroboration-oxidation produces aldehyde from terminal alkyne, while acid-catalyzed hydration converts terminal alkyne to methyl ketone.

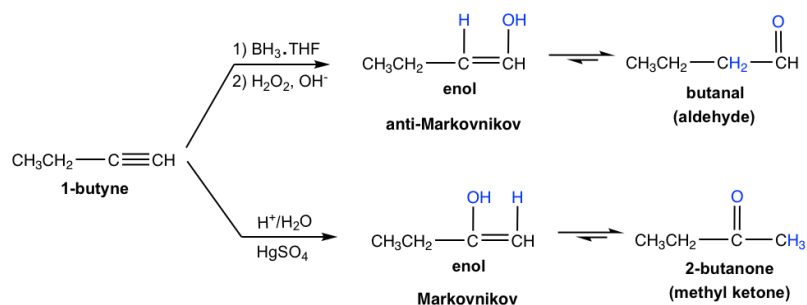
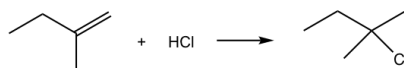
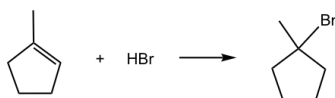
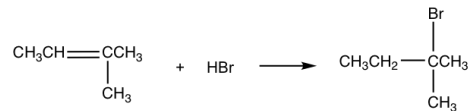

Figure 10.8t Hydroboration-Oxidation of Alkyne

This page titled [10.8: Alkynes](#) is shared under a [CC BY-NC-SA 4.0](#) license and was authored, remixed, and/or curated by [Xin Liu \(Kwantlen Polytechnic University\)](#).

10.9: Answers to Practice Questions Chapter 10

10.1 Show structure of the major product for following addition reactions.



10.2 For the addition of HBr to 3-methyl-1-butene, two products were observed. Show the reaction mechanism to explain the formation of both products.

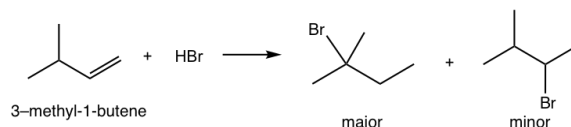

Mechanism:

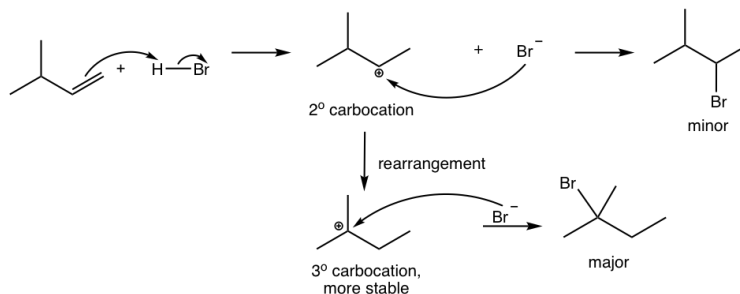

10.3 Show major product(s) for the following reactions.

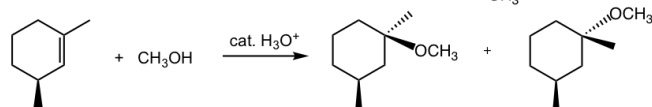
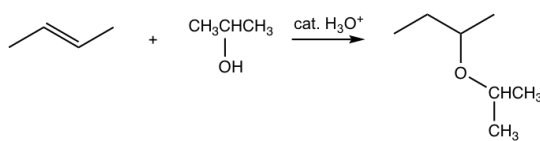
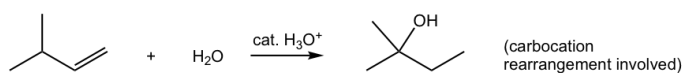

10.4 Show major product(s) of the following reactions.

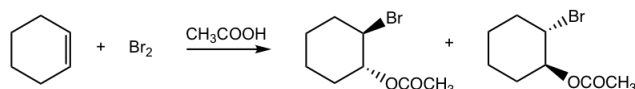
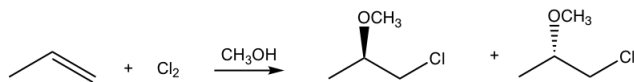

This page titled [10.9: Answers to Practice Questions Chapter 10](#) is shared under a [CC BY-NC-SA 4.0](#) license and was authored, remixed, and/or curated by [Xin Liu \(Kwantlen Polytechnic University\)](#).

Index

B

bromination

[9.4: Chlorination vs Bromination](#)

O

optical activity

[5.4: Optical Activity](#)

Detailed Licensing

Overview

Title: Organic Chemistry I (Liu)

Webpages: 93

Applicable Restrictions: Noncommercial

All licenses found:

- [CC BY-NC-SA 4.0](#): 87.1% (81 pages)
- [Undeclared](#): 12.9% (12 pages)

By Page

- [Organic Chemistry I \(Liu\) - CC BY-NC-SA 4.0](#)
 - [Front Matter - Undeclared](#)
 - [TitlePage - Undeclared](#)
 - [InfoPage - Undeclared](#)
 - [Table of Contents - Undeclared](#)
 - [Licensing - Undeclared](#)
 - [About the Author - Undeclared](#)
 - [Acknowledgements - Undeclared](#)
 - [Introduction - Undeclared](#)
 - [1: Basic Concepts in Chemical Bonding and Organic Molecules - CC BY-NC-SA 4.0](#)
 - [1.1: Chemical Bonding - CC BY-NC-SA 4.0](#)
 - [1.2: Lewis Structure - CC BY-NC-SA 4.0](#)
 - [1.3: Resonance Structures - CC BY-NC-SA 4.0](#)
 - [1.4: Resonance structures in Organic Chemistry - CC BY-NC-SA 4.0](#)
 - [1.5: Valence-Shell Electron-Pair Repulsion Theory \(VSEPR\) - CC BY-NC-SA 4.0](#)
 - [1.6: Valence Bond Theory and Hybridization - CC BY-NC-SA 4.0](#)
 - [1.7: Answers to Practice Questions Chapter 1 - CC BY-NC-SA 4.0](#)
 - [2: Fundamental of Organic Structures - CC BY-NC-SA 4.0](#)
 - [2.1: Structures of Alkanes - CC BY-NC-SA 4.0](#)
 - [2.2: Nomenclature of Alkanes - CC BY-NC-SA 4.0](#)
 - [2.3: Functional Groups - CC BY-NC-SA 4.0](#)
 - [2.4: IUPAC Naming of Organic Compounds with Functional Groups - CC BY-NC-SA 4.0](#)
 - [2.5: Degree of Unsaturation/Index of Hydrogen Deficiency - CC BY-NC-SA 4.0](#)
 - [2.6: Intermolecular Force and Physical Properties of Organic Compounds - CC BY-NC-SA 4.0](#)
 - [2.7: Answers to Practice Questions Chapter 2 - CC BY-NC-SA 4.0](#)
 - [3: Acids and Bases- Organic Reaction Mechanism Introduction - CC BY-NC-SA 4.0](#)
 - [3.1: Review of Acids and Bases and Ka - CC BY-NC-SA 4.0](#)
 - [3.2: Organic Acids and Bases and Organic Reaction Mechanism - CC BY-NC-SA 4.0](#)
 - [3.3: pKa of Organic Acids and Application of pKa to Predict Acid-Base Reaction Outcome - CC BY-NC-SA 4.0](#)
 - [3.4: Structural Effects on Acidity and Basicity - CC BY-NC-SA 4.0](#)
 - [3.5: Lewis Acids and Lewis Bases - CC BY-NC-SA 4.0](#)
 - [3.6: Answers to Practice Questions Chapter 3 - CC BY-NC-SA 4.0](#)
 - [4: Conformations of Alkanes and Cycloalkanes - CC BY-NC-SA 4.0](#)
 - [4.1: Conformation Analysis of Alkanes - CC BY-NC-SA 4.0](#)
 - [4.2: Cycloalkanes and Their Relative Stabilities - CC BY-NC-SA 4.0](#)
 - [4.3: Conformation Analysis of Cyclohexane - CC BY-NC-SA 4.0](#)
 - [4.4: Substituted Cyclohexanes - CC BY-NC-SA 4.0](#)
 - [4.5: Answers to Practice Questions Chapter 4 - CC BY-NC-SA 4.0](#)
 - [5: Stereochemistry - CC BY-NC-SA 4.0](#)
 - [5.1: Summary of Isomers - CC BY-NC-SA 4.0](#)
 - [5.2: Geometric Isomers and E/Z Naming System - CC BY-NC-SA 4.0](#)
 - [5.3: Chirality and R/S Naming System - CC BY-NC-SA 4.0](#)
 - [5.4: Optical Activity - CC BY-NC-SA 4.0](#)
 - [5.5: Fisher Projection - CC BY-NC-SA 4.0](#)
 - [5.6: Compounds with More Than One Chirality Centers - CC BY-NC-SA 4.0](#)
 - [5.7: Answers to Practice Questions Chapter 5 - CC BY-NC-SA 4.0](#)

- 6: Structural Identification of Organic Compounds- IR and NMR Spectroscopy - *CC BY-NC-SA 4.0*
 - 6.1: Electromagnetic Radiation and Molecular Spectroscopy - *CC BY-NC-SA 4.0*
 - 6.2: Infrared (IR) Spectroscopy Theory - *CC BY-NC-SA 4.0*
 - 6.3: IR Spectrum and Characteristic Absorption Bands - *CC BY-NC-SA 4.0*
 - 6.4: IR Spectrum Interpretation Practice - *CC BY-NC-SA 4.0*
 - 6.5: NMR Theory and Experiment - *CC BY-NC-SA 4.0*
 - 6.6: ^1H NMR Spectra and Interpretation (Part I) - *CC BY-NC-SA 4.0*
 - 6.7: ^1H NMR Spectra and Interpretation (Part II) - *CC BY-NC-SA 4.0*
 - 6.8: ^{13}C NMR Spectroscopy - *CC BY-NC-SA 4.0*
 - 6.9: Structure Determination Practice - *CC BY-NC-SA 4.0*
 - 6.10: Answers to Practice Questions Chapter 6 - *CC BY-NC-SA 4.0*
- 7: Nucleophilic Substitution Reactions - *CC BY-NC-SA 4.0*
 - 7.1: Nucleophilic Substitution Reaction Overview - *CC BY-NC-SA 4.0*
 - 7.2: $\text{S}_\text{N}2$ Reaction Mechanism, Energy Diagram and Stereochemistry - *CC BY-NC-SA 4.0*
 - 7.3: Other Factors that Affect $\text{S}_\text{N}2$ Reactions - *CC BY-NC-SA 4.0*
 - 7.4: $\text{S}_\text{N}1$ Reaction Mechanism, Energy Diagram and Stereochemistry - *CC BY-NC-SA 4.0*
 - 7.5: $\text{S}_\text{N}1$ vs $\text{S}_\text{N}2$ - *CC BY-NC-SA 4.0*
 - 7.6: Extra Topics on Nucleophilic Substitution Reaction - *CC BY-NC-SA 4.0*
 - 7.7: Answers to Practice Questions Chapter 7 - *CC BY-NC-SA 4.0*
- 8: Elimination Reactions - *CC BY-NC-SA 4.0*
 - 8.1: $\text{E}2$ Reaction - *CC BY-NC-SA 4.0*
 - 8.2: $\text{E}1$ Reaction - *CC BY-NC-SA 4.0*
 - 8.3: $\text{E}1/\text{E}2$ Summary - *CC BY-NC-SA 4.0*
 - 8.4: Comparison and Competition Between $\text{S}_\text{N}1$, $\text{S}_\text{N}2$, $\text{E}1$ and $\text{E}2$ - *CC BY-NC-SA 4.0*
 - 8.5: Answers to Practice Questions Chapter 8 - *CC BY-NC-SA 4.0*
- 9: Free Radical Substitution Reaction of Alkanes - *CC BY-NC-SA 4.0*
 - 9.1: Homolytic and Heterolytic Cleavage - *CC BY-NC-SA 4.0*
 - 9.2: Halogenation Reaction of Alkanes - *CC BY-NC-SA 4.0*
 - 9.3: Stability of Alkyl Radicals - *CC BY-NC-SA 4.0*
 - 9.4: Chlorination vs Bromination - *CC BY-NC-SA 4.0*
 - 9.5: Stereochemistry for Halogenation of Alkanes - *CC BY-NC-SA 4.0*
 - 9.6: Synthesis of Target Molecules- Introduction of Retrosynthetic Analysis - *CC BY-NC-SA 4.0*
 - 9.7: Answers to Practice Questions Chapter 9 - *CC BY-NC-SA 4.0*
- 10: Alkenes and Alkynes - *CC BY-NC-SA 4.0*
 - 10.1: Synthesis of Alkenes - *CC BY-NC-SA 4.0*
 - 10.2: Reactions of Alkenes- Addition of Hydrogen Halide to Alkenes - *CC BY-NC-SA 4.0*
 - 10.3: Reactions of Alkenes- Addition of Water (or Alcohol) to Alkenes - *CC BY-NC-SA 4.0*
 - 10.4: Reactions of Alkenes- Addition of Bromine and Chlorine to Alkenes - *CC BY-NC-SA 4.0*
 - 10.5: Reaction of Alkenes- Hydrogenation - *CC BY-NC-SA 4.0*
 - 10.6: Two Other Hydration Reactions of Alkenes - *CC BY-NC-SA 4.0*
 - 10.7: Oxidation Reactions of Alkenes - *CC BY-NC-SA 4.0*
 - 10.8: Alkynes - *CC BY-NC-SA 4.0*
 - 10.9: Answers to Practice Questions Chapter 10 - *CC BY-NC-SA 4.0*
- Back Matter - *Undeclared*
 - Index - *Undeclared*
 - Glossary - *Undeclared*
 - Detailed Licensing - *Undeclared*