

AERODYNAMICS AND AIRCRAFT PERFORMANCE



James F. Marchman
Virginia Tech

Aerodynamics and Aircraft Performance

James F. Marchman

Virginia Tech

This text is disseminated via the Open Education Resource (OER) LibreTexts Project (<https://LibreTexts.org>) and like the thousands of other texts available within this powerful platform, it is freely available for reading, printing, and "consuming."

The LibreTexts mission is to bring together students, faculty, and scholars in a collaborative effort to provide an accessible, and comprehensive platform that empowers our community to develop, curate, adapt, and adopt openly licensed resources and technologies; through these efforts we can reduce the financial burden born from traditional educational resource costs, ensuring education is more accessible for students and communities worldwide.

Most, but not all, pages in the library have licenses that may allow individuals to make changes, save, and print this book. Carefully consult the applicable license(s) before pursuing such effects. Instructors can adopt existing LibreTexts texts or Remix them to quickly build course-specific resources to meet the needs of their students. Unlike traditional textbooks, LibreTexts' web based origins allow powerful integration of advanced features and new technologies to support learning.



LibreTexts is the adaptable, user-friendly non-profit open education resource platform that educators trust for creating, customizing, and sharing accessible, interactive textbooks, adaptive homework, and ancillary materials. We collaborate with individuals and organizations to champion open education initiatives, support institutional publishing programs, drive curriculum development projects, and more.

The LibreTexts libraries are Powered by [NICE CXone Expert](#) and was supported by the Department of Education Open Textbook Pilot Project, the California Education Learning Lab, the UC Davis Office of the Provost, the UC Davis Library, the California State University Affordable Learning Solutions Program, and Merlot. This material is based upon work supported by the National Science Foundation under Grant No. 1246120, 1525057, and 1413739.

Any opinions, findings, and conclusions or recommendations expressed in this material are those of the author(s) and do not necessarily reflect the views of the National Science Foundation nor the US Department of Education.

Have questions or comments? For information about adoptions or adaptations contact info@LibreTexts.org or visit our main website at <https://LibreTexts.org>.

This text was compiled on 05/13/2026

TABLE OF CONTENTS

How to Adopt or Adapt this Book

Licensing

Acknowledgments

Preface

Introduction

1: Introduction to Aerodynamics

2: Propulsion

3: Additional Aerodynamics Tools

4: Performance in Straight and Level Flight

5: Altitude Change - Climb and Guide

6: Range and Endurance

7: Accelerated Performance - Takeoff and Landing

8: Accelerated Performance - Turns

9: The Role of Performance in Aircraft Design - Constraint Analysis

10: Appendix - Airfoil Data

Index

Glossary

Detailed Licensing

Welcome to the Engineering Library. This Living Library is a principal hub of the [LibreTexts project](#), which is a multi-institutional collaborative venture to develop the next generation of open-access texts to improve postsecondary education at all levels of higher learning. The LibreTexts approach is highly collaborative where an Open Access textbook environment is under constant revision by students, faculty, and outside experts to supplant conventional paper-based books.

Licensing

A detailed breakdown of this resource's licensing can be found in [Back Matter/Detailed Licensing](#).

Acknowledgments

Thanks are due to my colleague of many years, the late Dr. Fred Lutze, whose teaching notes, given to me over 30 years ago, formed the basis for the materials in Chapters 4 – 8. To those notes I have added material gleaned from my own experience in subsonic aerodynamic research and teaching and as a private pilot and former aircraft owner. The material presented also undoubtedly has been influenced by several textbooks that we have used in teaching various versions of an aircraft performance course in the past. The best of these influences came from my friend John Anderson whose many excellent textbooks have become an essential part of every aerospace engineering student's basic library.

Finally, thanks always must go to the hundreds of students who have been subjected to my methods and demands in several versions of aircraft performance courses. While some of them have sat in a stupor in the back of the classroom oblivious to everything, many have responded, questioned, and even excelled, making the experience worthwhile for us all. Just as many past students have called my attention to errors in previous editions of this text, I am confident that future students will continue to delight in finding mistakes in their professor's work; hence, this work in process cannot help but continue to improve.

James F. Marchman, III
Summer 2004

Editorial Acknowledgments

The 2021 public release of this work was made possible by the University Libraries at Virginia Tech through its Open Education Initiative (<https://guides.lib.vt.edu/oer/grantees>) which provides development assistance and financial support to Virginia Tech faculty who wish to use, create, or adapt openly licensed teaching materials to support student learning.

This version has benefited from editorial, accessibility, copyright and design modifications from the original manuscript as contributed or directed by the University Libraries. These include:

- Converting the original manuscripts from PDF and MSWord into the Pressbooks publishing platform;
- Conversion of mathematical equations from images to machine-readable formulas using MathML;
- Replacement of pixelated graphics and in-copyright figures with redrawn, public domain, or openly-licensed figures;
- Addition of alternative text for all figures and illustrations; and
- Subject-matter expert naming and renumbering previously unnamed figures.

In addition, a small number of typos, formula errors, and figure details were discovered by subject matter experts and corrected by the editorial team.

Editorial Team

Editorial Team Lead / Project Manager: Anita Walz

Pressbooks / Editorial Support: Kindred Grey, Sarah Mease, Claire Colvin, Kathleen Manning

MathML Conversion: Sarah Mease, Anita Walz

Graphic Design: Claire Colvin (Ch 2 engine graphics), Kindred Grey (other graphics)

Alternative Text (alt text), and figure review and naming: Joseph Brooks

Cover Design: Kindred Grey

Special thanks to

Christa Miller, Accessible Technology, Virginia Tech

Pat Artis, Craig Woolsey, Matthew Kuester, and Joseph Brooks, Kevin T. Crofton Department of Aerospace and Oceanic Engineering, Virginia Tech

Preface

This text evolved from a set of notes that have been continually revised for over 30 years of teaching courses in Aircraft Performance, Aerodynamics, and Aircraft Design. The primary motivations for transforming these notes into textbook form were the unjustifiably high prices that book publishing companies set for engineering textbooks and the need for a single text that covered just enough basic aerodynamics and aircraft performance to satisfy the needs of a “stand-alone” course in airplane performance with a design emphasis.

There are many excellent textbooks that cover the subject of Aircraft Performance as well as related aerodynamic theory. These include the texts listed below:

- Anderson, John D., Jr., *Aircraft Performance and Design*, McGraw Hill, New York, 1999 and later editions.
- Houghton, E. L. and Carruthers, N. B., *Aerodynamics for Engineering Students*, Arnold, London, 1982 and later editions
- Eshelby, Martin E. *Aircraft Performance, Theory and Practice*, Arnold, London, 2000
- Mair, W. Austyn and Birdsall, David L. *Aircraft Performance*, Cambridge Aerospace Series 5, Cambridge University Press, 1992

I especially recommend the text of my long-time friend, John Anderson, who has inspired my increasing interest in aviation history with the historical inserts found in all of his excellent books and through his outstanding talks on the history of both aviation and aerodynamics. I only wish that the publishers of these texts could make them available to students at a reasonable price.

The major publishing houses like to tell us that the high prices they charge for engineering and technical texts are the result of publication of relatively small numbers of books (when compared to main line literature). The truth is that one can go to any professional printing company in the country and get 1000 copies of a professionally bound, 200 page, soft cover book printed at a cost of less than \$10 per copy. I know this because I have done so with another book that I authored and published on my own. I also know that textbook industry often encourages authors to make un-needed revisions of their books every five or so years for the sole purpose of making used copies of their past editions “obsolete”, and that it is a common practice to increase the price of a textbook approximately \$5 every year, even if costs have not risen a penny.

Hence, as mentioned in the first paragraph above, one motivation behind creating this text is to allow my students to obtain a publication that will serve their needs at a savings of \$100 or more. The other motive is to give them only the material that they really need for their course and allow them to find the coverage needed in other courses in the texts required for those courses. Too many authors today, often encouraged by their publishers, seem to want to create textbooks that cover multiple subjects. The result is that students end up having to buy three or four different texts, all covering the same wide range of subjects such as subsonic aerodynamics, supersonic aerodynamics, aircraft performance, and boundary layer theory in one volume, when the professors teaching those four separate courses all prefer books by different authors.

This text is designed for a course in Aircraft Performance that is taught before the students have had any course in fluid mechanics, fluid dynamics, or aerodynamics. The text is meant to provide the essential information from these types of courses that is needed for teaching basic subsonic aircraft performance, and it is assumed that the students will learn the full story of aerodynamics in other, later courses. The text assumes that the students will have had a university level Physics sequence in which they will have been introduced to the most fundamental concepts of statics, dynamics, fluid mechanics, and basic conservation laws that are needed to understand the coverage that follows. Separate courses in engineering statics and dynamics are helpful but not necessary. It is also assumed that students will have completed first year university level calculus sequence plus a course in multi-variable calculus. Any student who takes a course using this text after completing courses in aerodynamics or fluid dynamics should find the chapters of this book covering those subjects an interesting review of the material, perhaps with a different emphasis than previously seen.

I have tried to present much of the material in this text from the point of view of a pilot since it is essential that the aircraft performance engineer be able to relate to pilots and their needs and vocabulary. While being an aerospace engineer or even a performance specialist has little to do with actually flying an airplane, it could easily be argued that one’s real world experience at the controls of an airplane gives a valuable perspective in teaching either aerodynamics or aircraft performance. I owe my own “hands-on” flying experience to two people, my father who began flying in his early teens and continued to pilot his own plane almost until he died at age 80, and to a former undergraduate and Masters student, David Manor, who challenged me to finally get my pilot’s license and provided free flight instruction. I will never live up to my father’s wish that I share his intense love of being

in an airplane whenever possible or to Dr. Manor's desire that all of this flight students become aerobatic pilots; however, even the relatively mundane experience of flying in a straight line from point A to point B has its satisfying moments if one is willing to put up with the hassles imposed by the FAA and the weather and the outrageous expenses of flight that seem to result primarily from government regulation and the unlimited greed of American lawyers. A few years ago I fell victim to those high costs and frustrations of flying and airplane ownership and sold my airplane. Nonetheless, the experience of being a pilot will always flavor the way I teach any aerospace engineering course.

On the subject of the emphases of this text, the reader will find that, unlike many technical books this one spends less time and space than normal on rigorous derivations of theory and more time emphasizing the practical uses and limitations of the resulting theories. I have also tried to stress a need for assessing the practicality of one's answers and for the rigorous tracking of units through problem solutions. It has been my experience that the average student today, like the general population, has very little "feel" for physical reality and even less appreciation for reality expressed in unfamiliar unit systems. Unfortunately, the stress on the use of the SI unit system in every course taken from kindergarten through college has greatly exacerbated this lack of appreciation for physical reality.

Other than some understanding of the physical size of a liter (or is it litre?) that comes from buying everything from Coke to beer in liter containers, the typical American student has absolutely no feel for the physical size any SI unit. The exception might be some appreciation for the physical length of a meter (or is it a metre?) among people who have been involved in some form of track or swimming or those who were taught that a meter is a few inches longer than a yard. Despite the fact that American students have been inundated by SI units in school since their fifth birthday, few would have any idea of their own weight in Newtons (or mass in kilograms) or their height in meters. It is no wonder that when the student in Aircraft Performance calculates that the speed of flight of a Cessna 152 is 750 meters per second, he or she goes merrily on his or her way without questioning the physical reality of that answer.

And it is not just the SI system that is the problem. Since most students have been taught most courses using SI units instead of the more familiar everyday "English" units (the British call these "American" units), they also often lack any ability to think about technical problems and the physical reality of their solutions in terms of "English" unit answers. Would 1000 feet per second be an acceptable speed for that Cessna 152? Throw in a few pressures in Pascals or pounds per square foot and mix in a few densities in kilograms per cubic meter or slugs per cubic foot and today's student has absolutely no idea if the magnitude of any number is right or wrong. It is even rare today to find an American student who has any idea how many feet are in a mile.

Contrary to the beliefs of those who strongly advocate conversion of American society to SI units, this is definitely not an American problem. I have worked with students from all over the world and have yet to find one who can give his own body weight in Newtons or has any sense of how many Pascals might represent a higher than standard air pressure. And has anyone anywhere seen an advertisement for a car that bragged about how many Watts the piston engine could produce?

It would also be nice if the aircraft performance engineer could relate to the airplane pilot who is used to measuring altitudes in feet, speeds in knots, and air pressures in either millibars or inches of mercury, regardless of his or her country of origin. In order to deal with all of these problems, a strong emphasis will be placed on the need to always carry the proper units with every number (except, of course, those that are unitless) completely through any problem and to make absolutely sure that the final units associated with any answer are the proper ones. In a problem where the student is asked to calculate the top speed of an aircraft, if the answer comes out with units of meters squared per second, it should be obvious that an error has been made somewhere. The same strong emphasis will be placed on assessing the physical reality of the magnitudes of all answers. Can a Cessna 152, a single engine piston powered aircraft, fly at a speed of 600 ft/sec or 300 meters per second or 100 knots? (one of these is reasonable).

In addition to the use of mixed units (with a preference for "English") I have provided graph paper with the homework problems at the end of the text and I insist that my own students plot the results of their work on this paper by hand rather than using computer plotting routines.

This, like my insistence on carrying units through solutions with all numbers, is something that I firmly believe encourages students to actually take the time to think about their work. There is far too much tendency for students to want to merely plug numbers into equations and let the computer do the math and the plotting and then to assume that it is impossible for the computer to do anything wrong. The provided graphs already have their axes defined and enumerated, thus providing the student with some idea of the range of values that should come out of his or her calculations.

In this third edition of this work I have completely rewritten the first three chapters of the text and added a ninth chapter dealing with the subject of “constraint analysis”. In the first three chapters I have attempted to better organize the presentation of the basic aerodynamic and fluid dynamic concepts that will be needed for the later development of aircraft performance relationships. I have eliminated some of the more rigorous derivations of fluid dynamic theory and tried instead to present those resulting equations and concepts, such as Bernoulli’s equation and mass and momentum conservation, in their most useable forms and to emphasize the assumptions related to these forms and the limitations that they place on the use of those concepts and equations. I have always felt that the main value in actually taking students through the complete derivation of the equations they will eventually use is in showing where the important assumptions come from and why they were made. However, it has been my experience that most students simply tune out during such derivations or, if they think they will have to feed back the derivations on a test, they resort to mindless memorization of the steps involved and totally lose sight of the important aspects of the derivations, that is, the impact of the often purely mathematically based assumptions on the subsequent utility of the final equations.

I have totally replaced the third chapter of the previous editions, a chapter that was originally written for another purpose and which was written in a different style and form from the rest of the text. Many of the concepts presented in that chapter were simply not relevant for a first course in aircraft performance. The important parts of that material have been merged into the first two chapters of this edition in such a way as to follow a better progression than before and to relate better to the subsequent direction of the text.

The third chapter now contains some optional (for an introductory aircraft performance course) coverage of two-dimensional (airfoil) and three-dimensional (wing) theory basics. These should help satisfy the curiosity of those students who would like some very basic tools that will enable them to perform their own elementary assessments of the way geometry factors such as airfoil camber and wing aspect ratio might affect both aerodynamic and aircraft performance.

Chapter nine covers new material that I first introduced in my sophomore level aircraft performance course in the Spring of 2003. The chapter covers the concept of “constraint analysis”, a widely used method of making a simultaneous assessment of several performance parameters such that an aircraft can be designed to meet these objectives in an optimum manner even though the outcomes might not be optimum when considered individually. In other words, even though earlier chapters have discussed how to get the best range or best endurance in cruise or the minimum takeoff distance or the maximum rate of turn, there was no real discussion of how to put these together in a single aircraft design. The best thrust or wing area for optimum range may be far different from those for best rate of turn or climb. Constraint analysis is a method of assessing aircraft performance in its various modes in terms of two ratios, the thrust-to-weight ratio and the wing loading (weight to planform area ratio).

While some introductory level aerospace engineering texts discuss a form of constraint analysis, they usually do so in a very limited context or are aimed at one particular type of aircraft (fighters, for example). Chapter 9 attempts to present this method in a general way that can be applied to any type of aircraft. Many textbooks on aircraft design also look at constraint analysis methods but they usually do so in an overly terse manner which assumes that the student can read between the lines to figure out the basis for the various plots presented. The coverage in chapter nine is based on the material I present in my own senior level aircraft design course and that presented in the design text that I co-authored with Lloyd Jenkinson (*Aircraft Design Projects for Engineering Students*, AIAA, 2002).

James F. Marchman, III
Summer 2004

About the Author

Dr. James F. Marchman, III is Professor Emeritus of Aerospace and Ocean Engineering and a former Associate Dean of Engineering at Virginia Tech where he taught and conducted research in aerodynamics, aircraft performance, aircraft design and other areas over a 40 year career. His textbook, *Aircraft Design Projects For Engineering Students*, coauthored by Professor Lloyd R. Jenkinson of Loughborough University in the United Kingdom, published by Butterworth-Heinemann in 2003 has been used by students around the world.

Introduction

From the Author

There are numerous textbooks on aircraft aerodynamics and performance. Many of these do wonderful jobs of starting from the basics of physics and math and deriving all of the important fluid dynamic and flight dynamics equations that ultimately determine the way an airplane flies and behaves. These are, however, often written with so much mathematical and scientific rigor that students get lost in the math and fail to appreciate the physical importance of the assumptions made along the way and, therefore, don't understand how to use the results. Other texts seek to simplify the rigor of the derivations and emphasize only the final equations, even to the point of inserting numerical values for many constants in the equations to such an extent that they only work when used with predetermined sets of assumptions and units. A common result is student misuse of the equations in situations where the assumptions are not valid or with inappropriate sets of units. In this book I will attempt a different approach, discussing the physics and mathematical bases while stressing the assumptions made in the development of the relationships that are presented, but I will do this without dwelling on all the little steps along the way. It will be assumed that the reader who wants more rigor in developing these relationships can go to the many other texts that do a very admirable job of presenting that level of detail.

The statement above does not mean I will avoid all derivations of equations but it does mean I will not go into a lot of detail, especially where derivations can get bogged down in mathematical detail that serves little purpose beyond appealing to math aficionados.

This book will seek to look into the basics of both airplane aerodynamics and aircraft performance. While we will occasionally look at other parts of the flight regime, the emphasis will be on subsonic flight and its associated *incompressible* flow. We will examine and emphasize the limitations of looking at flight in this manner and discuss a few of the consequences of venturing beyond these limits into the *compressible* flow regime, but we will not look in any detail into flight and performance at higher speeds. We will also keep our discussion of many important elements of aerodynamics at a very basic level, emphasizing general results more than detailed methods used to get those results. There are many fine textbooks in aerodynamics that are available to the reader who wishes to go beyond the level of this book and the student of aeronautical or aerospace engineering will undoubtedly use one or more of those texts in future courses.

The two primary areas of concern in this text are aerodynamics and performance. In general, aerodynamics involves studying the relationships of pressure and flow speed as air flows around a streamlined shape such as an airplane or a wing. If a flow over a wing gives a lower pressure on top of the wing than on the bottom, we have lift, and aerodynamics seeks to explain that phenomenon and examine how shaping the wing in both two and three dimensions can create more lift in a more efficient way. If the pressures on the front of the airplane or wing are greater than those at the back, we get drag, and the aerodynamicist wants to minimize this drag at the same time as the lift is maximized. It is also important to look at how those pressures are distributed over the wing because that distribution can influence the likelihood of the flow breaking away from the wing and causing higher drag or wing stall. The pressure distribution can also determine the nature of the flow over the wing or airplane right at the surface and this influences the kind of drag that results from the friction of the air moving over the surface. These forces (lift and drag) are the fundamental forces that will concern us when we look at airplane performance.

The pressure distributions over the wing and other parts of an airplane also determine the tendency of the plane to rotate around its center of gravity (center of mass) in ways that we refer to as pitch (nose up or down), roll (one wing up, the other down), or yaw (nose left or right). These types of motion are important to an entirely different subject, that of airplane dynamics, stability and control.

A third subject for later study that is strongly affected by these aerodynamic forces on the aircraft and its wing is structures. Obviously, the airplane must be designed to hold together under the stresses caused by these forces. The airplane structure must be as light as possible while giving the strength needed to resist damage under the worst of the aerodynamic loads for which the plane was designed. And we sometimes forget that the other primary role of the structure is to give the shape that is needed to produce the desired pressure and friction forces.

One thing we will attempt to do as we look at basic aerodynamics and performance is to make sure that we do not look at these topics in isolation, but consider their impact on aircraft dynamics and structural design. For example, we will find that a certain type of distribution of aerodynamic lift forces along the span of the wing from one tip to the other will produce an "ideal" or

“minimum drag” loading. However, this ideal aerodynamic loading is not the ideal structural loading, and in the design of a real airplane, both needs must be considered. We will also find that a high “aspect ratio”, or a large ratio of wing span for a given wing area, will give both better aerodynamic performance and better airplane performance than a wing with a low “aspect ratio”. On the other hand, the wing that is best for lift and drag and overall airplane performance may not be very good for optimum aircraft dynamic performance in such things as roll maneuvers.

Two other very important things that will be emphasized in this text will be a **rigorous attention to units** and the need for **continual reality checks** to make sure we are getting results that are “in the ballpark”; i.e., that they make sense in the real world. Too often, it is inattention to these two subjects that cause students the most woe in getting the “right answers” on tests and in homework, and it was inattention to one of these subjects that resulted in a very expensive space mission to Mars missing the entire planet a couple of years ago.

Many engineering textbooks merely assume that all work will always be done in a particular unit system (usually SI) and that the equations developed include constants appropriate to the chosen system and no other. We will not do that. All equations in this text will be completely generic with respect to units, with no assumptions about the use of SI or English (American) or any other system of units. This is meant to force the student to carry appropriate units with every number and resolve those units as needed for the solution of the equation. This should, in fact, be helpful in assuring that the “answer” to the calculation is correct since, if the units come out wrong, it is a pretty good indication that the numbers are also wrong.

This approach will undoubtedly bother avid proponents of one unit system or another, those people who believe that only one unit system is “politically correct” and should always be used even if its users have absolutely no feel for the meaning or values of the units used. I believe that it is, nonetheless, important to have equations that force the user to take care to resolve both numbers and units for two reasons. First, resolving the units in the equations is, as mentioned above, a rather easy and important way to make sure that the “answer” is, indeed, correct. Second, regardless of how ideal our world would be if everyone used the same unit system for everything they do, that is not the case, and it is my experience after working with engineering faculty and students in Europe and Asia that few people really have a good physical feel for many of the basic SI units. I have been asked by French engineers what a Pascal is, and many fail to grasp that the Newton is a proper unit of weight because much of the world prefers to ignore the effects of gravity and work only with mass. Until I find a handful of people anywhere in the world who can tell me their weight in Newtons, without doing mental conversions from pounds (in the U. S.) or “stones” (in England) or converting from kilograms of mass, I will not be convinced that we can just assume that the use of SI units in textbooks eliminates unit problems.

This also relates to the important idea of gaining an appreciation for proper magnitudes of the properties that we will study in this text. I am always amazed when a student is perfectly happy turning in a paper in which she or he has calculated that a single engine, propeller driven airplane is cruising at Mach 2! It would seem apparent that the answer is very wrong. In reality, the student probably has done a calculation without paying attention to units and has come up with an answer of something like 2000 feet per second and hasn’t bothered to think that this is about twice the speed of sound. Perhaps if the answer had been calculated in miles per hour, the magnitude of the value would have made a bigger impression and set off a mental alarm. On the other hand, had the answer been found as 600 meters (metres?) per second, most American students would have no idea how fast this really is. Even in Britain, where highway speeds are still posted in miles per hour, students may not have immediately recognized that this answer violated an incompressible flow assumption. So, just as we would suspect that we had been cheated if we stepped on a coin operated scale and were told that we weighed 2500 pounds because we have a physical feel for the proper range of human weights, we need to develop a sense of “ballpark” answers for aerodynamic forces, speeds, aircraft ranges and endurance and similar parameters that we will encounter in this text.

The objective of this text is to provide a “stand alone” coverage of basic, subsonic, aircraft performance preceded by an introduction to the basics of aerodynamics that will provide a background sufficient to the understanding of the subjects to be studied in aircraft performance. Aircraft performance calculations are essentially the result of simply balancing the forces on an airplane, lift against weight and thrust against drag, and looking at how these balances work together and how they are affected by things like speed and altitude. To understand this balance we must know something about these aerodynamic forces that we call lift and drag and understand something about how they vary with speed and altitude. This will be our objective in the first three chapters, to learn about aerodynamics and to learn about how the properties of the atmosphere change with altitude. We will also try to gain some sense of how the pilot sees his or her operating environment using the instrumentation available in the cockpit and how that might relate to the performance and operation of the airplane.

Once we have looked at some aerodynamics we will begin to use our knowledge to explore the way an airplane performs. How fast or slow can it fly? How high can it climb and what is the rate of climb? How far can it glide? How far can it fly on a tank of fuel? All of these can be determined by just balancing forces. We will then look at a couple of cases where we must consider acceleration. These are takeoff/landing and turning.

Finally, we will take a look at how to try to balance all of the things we have learned about performance in order to design an airplane that will do everything we want; i.e., to takeoff and land in a desired distance and also climb at the desired rate, cruise at the target speed, etc.

Homework Problems

The homework problems at the end of each chapter build on the examples in the text to provide experience in working with the materials and theoretical methods presented in the text. Many of the problems ask for the plotting of graphs and graph paper is provided for that purpose. The first question many students will ask is: “Do I have to use the graph paper? Can’t I plot these using Excel or some other computer package?”

It is my feeling that there is value in learning to plot by hand and, in using these predimensioned plot axes, the student is shown some limit on the scope of the solution; i.e., if his or her graph won’t fit the provided scale, it is wrong! Plotting the data by hand offers the “opportunity” for the person doing the plotting to think a little about the points being plotted and to determine whether they make sense physically. Many aircraft performance calculations are related to flight “within the envelope” where the “envelope” is literally the area inside the curve on a plot and the visualization of such an envelope can help one understand what is happening. It is my experience that for some reason those who have their computer do the plot are much more likely to be perfectly happy with results that make no sense at all (that Mach 3 Cessna 152!) than are those who plot the results by hand, perhaps simply because hand plotting of results forces one to take the time to look at those results and not assume they are correct just because they were generated by a computer program.

In plotting data the actual data points which are calculated (or obtained from experiment) should be shown with a small symbol such as a square or a circle or a triangle. The general curve should be faired through those points following a smooth curve or path and not as a game of connect the dots as computers are prone to do.

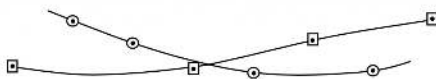

Figure P1: Example Data Sets and Plotting Styles

It should also be remembered that a minimum number of points are necessary to define a curve. Two data points tells nothing about the trends and three points are marginal. The student should remember that when plotting performance data he or she must plot enough points to get a good definition of the curve in the region where information is sought. For example, there is no way to tell from the three data points below where the minimum might lie.

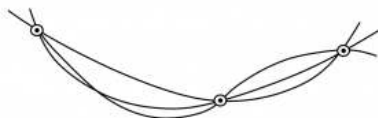

Figure P2: Curvature Uncertainty Due to Insufficient Data Points

References

Figure P1: Kindred Grey (2021). “Example Data Sets and Plotting Styles.” [CC BY 4.0](https://creativecommons.org/licenses/by/4.0/). Adapted from James F. Marchman (2004). [CC BY 4.0](https://creativecommons.org/licenses/by/4.0/). Available from <https://archive.org/details/intro-hw-1>

Figure P2: Kindred Grey (2021). “Curvature Uncertainty Due to Insufficient Data Points.” [CC BY 4.0](https://creativecommons.org/licenses/by/4.0/). Adapted from James F. Marchman (2004). [CC BY 4.0](https://creativecommons.org/licenses/by/4.0/). Available from <https://archive.org/details/intro-hw-2>

1: Introduction to Aerodynamics

Chapter 1. Introduction to Aerodynamics

1.1 Aerodynamics

Aerodynamics is probably the first subject that comes to mind when most people think of Aeronautical or Aerospace Engineering. Aerodynamics is essentially the application of classical theories of “fluid mechanics” to external flows or flows around bodies, and the main application which comes to mind for most aero engineers is flow around wings.

The wing is the most important part of an airplane because without it there would be no lift and no aircraft. Most people have some idea of how a wing works; that is, by making the flow over the top of the wing go faster than the flow over the bottom we get a lower pressure on the top than on the bottom and, as a result, get lift. The aero engineer needs to know something more than this. The aero engineer needs to know how to shape the wing to get the optimum combination of lift and drag and pitching moment for a particular airplane mission. In addition he or she needs to understand how the vehicle’s aerodynamics interacts with other aspects of its design and performance. It would also be nice if the forces on the wing did not exceed the load limit of the wing structure.

If one looks at enough airplanes, past and present, he or she will find a wide variety of wing shapes. Some aircraft have short, stubby wings (small wing span), while others have long, narrow wings. Some wings are swept and others are straight. Wings may have odd shapes at their tips or even attachments and extensions such as winglets. All of these shapes are related to the purpose and design of the aircraft.

In order to look at why wings are shaped like they are we need to start by looking at the terms that are used to define the shape of a wing.

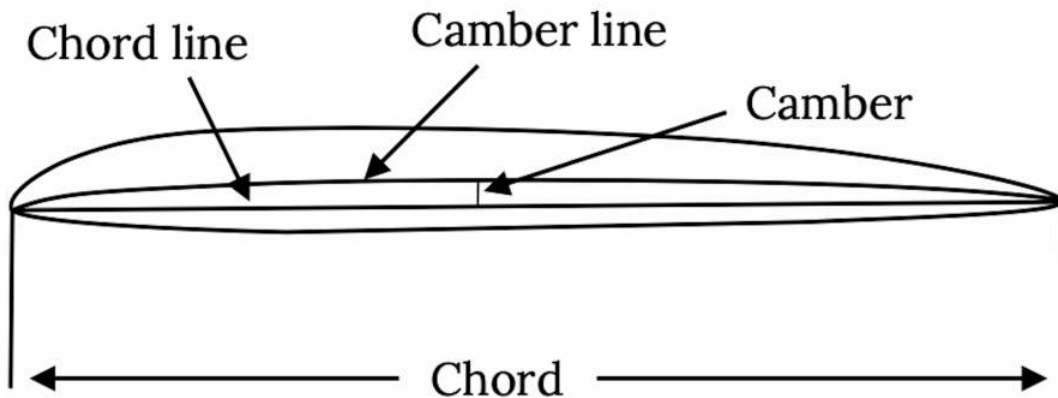

Figure 1.1: Airfoil Terminology

A two dimensional slice of a wing cut parallel to the centerline of the aircraft fuselage or body is called the **airfoil section**. A straight line from the airfoil section leading edge to its trailing edge is called the **chord line**. The length of the chord line is referred to as the **chord**. A line drawn half way between the airfoil section’s upper and lower surfaces is called the **camber line**. The maximum distance between the camber line and chord line is referred to as the airfoil’s **camber** and is usually enumerated as a **percent of chord**. We will see that the amount of airfoil camber and the location of the point of maximum camber are important numbers in defining the shape of an airfoil and predicting its performance. For most airfoils the maximum camber is on the order of zero to five percent and the location of the point of maximum camber is between 25% and 50% of the chord from the airfoil leading edge.

When viewed from above the aircraft the wing shape or **planform** is defined by other terms.

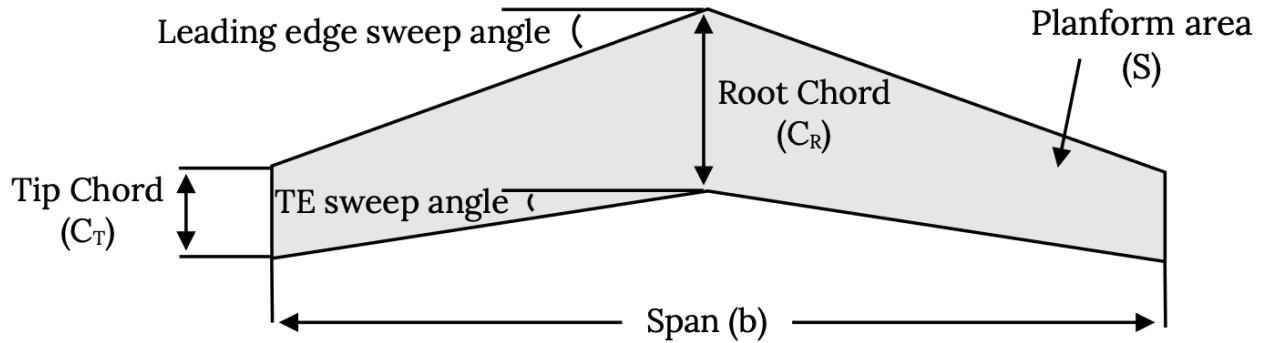

Figure 1.2: Wing Planform Terminology

Note that the **planform area** is not the actual surface area of the wing but is “projected area” or the area of the wing’s shadow. Also note that some of the abbreviations used are not intuitive; the **span**, the distance from wing tip to wing tip (including any fuselage width) is denoted by **b** and the **planform area** is given a symbol of “ **S** ” rather than perhaps “ **A** ”. Sweep angles are usually given a symbol of lambda (λ).

Another definition that is based on the planform shape of a wing is the **Aspect Ratio (AR)**.

$$AR = b^2/S.$$

Aspect ratio is also the span divided by the “mean” or average chord. We will later find that aspect ratio is a measure of the wing’s efficiency in long range flight.

Wing planform shapes may vary considerably from one type of aircraft to another. Fighter aircraft tend to have low aspect ratio or short, stubby wings, while long range transport aircraft have higher aspect ratio wing shapes, and sailplanes have yet higher wing spans. Some wings are swept while others are not. Some wings have triangular or “delta” planforms. If one looks at the past 100 years of wing design he or she will see an almost infinite variety of shapes. Some of the shapes come from aerodynamic optimization while others are shaped for structural benefit. Some are shaped the way they are for stealth, others for maneuverability in aerobatic flight, and yet others just to satisfy their designer’s desire for a good looking airplane.

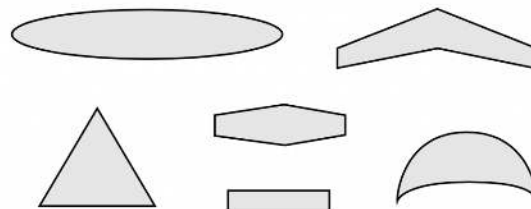

Figure 1.3: Some Wing Planform Shapes

In general, high aspect ratio wings are desirable for long range aircraft while lower aspect ratio wings allow more rapid roll response when maneuverability is a requirement. Sweeping a wing either forward or aft will reduce its drag as the plane’s speed approaches the speed of sound but will also reduce its efficiency at lower speeds. Delta wings represent a way to get a combination of high sweep and a large area. Tapering a wing to give it lower chord at the wing tips usually gives somewhat better performance than an untapered wing and a non-linear taper which gives a “parabolic” planform will theoretically give the best performance.

In the following material we will take a closer look at some of the things mentioned above and at their consequences related to the flight capability of an airplane.

Before we take a more detailed look at wing aerodynamics we will first examine the atmosphere in which aircraft must operate and look at a few of the basic relationships we encounter in “doing” aerodynamics.

1.2 Air, Our Flight Environment

Airplanes operate in air, a gas made up of nitrogen, oxygen, and several other constituents. The behavior of air, that is the way its properties like temperature, pressure, and density relate to each other, can be described by the ***Ideal or Perfect Gas Equation of State***:

$$P = \rho RT$$

where **P** is the barometric or **hydrostatic pressure**, **ρ** is the **density**, and **T** is the **temperature**. **R** is the **gas constant for air**. In this equation the temperature and pressure must be given in *absolute* values; in other words, temperature must be in **Kelvin** or **Rankine**, not Celsius (Centigrade) or Fahrenheit. Of course the units must all be consistent with those used in the gas constant:

$$R_{\text{air}} = 1716.16 \text{ ft}^2 / \text{sec}^2 \cdot \text{R} = 287.05 \text{ N} \cdot \text{m} / \text{kg} \cdot \text{K}$$

1.3 Units

This brings us to the subject of units. It is important that all the units in the perfect gas equation be compatible; i.e., all English units or all SI units, and that we be careful if solving for, for example, pressure, to make sure that the units of pressure come out as they should (pounds per square foot in the English system or Pascals in SI). Unfortunately many of us don't have a clue as to how to work with units.

It is popular in U. S. scientific circles to try to convince everyone that Americans are the only people in the world who use "English" units and the only people in the world who don't know how to use SI units properly. Nothing could be further from the truth. No one in the world actually uses SI units correctly in everyday life. For example, the rest of the world commonly uses the Kilogram as a unit of weight when it is actually a unit of mass. They buy produce in the grocery store in Kilograms, not Newtons. You would also be hard pressed to find anyone in the world, even in France, who knows that a Pascal is a unit of pressure. Newtons and Pascals are simply not used in many places outside of textbooks. In England the distances on highways are still given in miles and speeds are given in mph even as the people measure shorter distances in meters (or metres), and the government is still trying to get people to stop weighing vegetables in pounds. There are many people in England who still give their weight in "stones".

As aerospace engineers we will find that, despite what many of our textbooks say, most work in the industry is done in the English system, not SI, and some of it is not even done in proper English units. Airplane speeds are measured in miles per hour or in knots, and distances are often quoted in nautical miles. Pressures are given to pilots in inches of mercury or in millibars. Pressures inside jet and rocket engines are normally measured in pounds-per-square-inch (psi). Airplane altitudes are most often quoted in feet. Engine power is given in horsepower and thrust in pounds. We must be able to work in the real world, as well as in the politically correct world of the high school or college physics or chemistry or even engineering text.

It should be noted that what we in America refer to as the "English" unit system, people in England call "Imperial" units. This can get really confusing because "imperial" liquid measures are different from "American" liquid measures. An "imperial" gallon is slightly larger than an American gallon and a "pint" of beer in Britain is not the same size as a "pint" of beer in the U. S.

So, there are many possible systems of units in use in our world. These include the SI system, the pound-mass based English system, the "slug" based English system, the cgs-metric system, and others. We can discuss all of these in terms of a very familiar equation, Isaac Newton's good old $F = ma$. Newton's law relates units as well as physical properties and we can use it to look at several common unit systems.

$$\text{Force} = \text{mass} \times \text{acceleration}$$

$$1 \text{ Newton} = 1 \text{ kg} \times 1 \text{ meter/sec}^2$$

$$1 \text{ pound-force} = 1 \text{ pound-mass} \times 32.17 \text{ ft/sec}^2$$

$$1 \text{ Dyne} = 1 \text{ gram} \times 1 \text{ cm/sec}^2$$

$$1 \text{ pound-force} = 1 \text{ slug} \times 1 \text{ ft/sec}^2$$

The first and last of the above are the systems with which we need to be thoroughly familiar; the first because it is the "ideal" system according to most in the scientific world, and the last because it is the semi-official system of the world of aerospace engineering.

In using any unit system there are three basic requirements:

1. Always write units with any number that has units.
2. Always work through the units in equations at the same time that you work out the numbers.
3. Always reduce the final units to their simplest form and verify that they are the appropriate units for that number.

Following the above suggestions would eliminate about half of the wrong answers found on most student homework and test papers.

In doing engineering problems one should carry through the units as described above and make sure that the units make sense for the answer and that the magnitude of the answer is reasonable. *Good students do this all the time while poor ones leave everything to chance.*

The first part of this is simple. If the units in an answer don't make sense, for example, if the *speed* for an airplane is calculated to be 345 *feet per pound* or if we calculate a *weight* to be 1500 *kilograms per second*, it should be easy to recognize that something is wrong. A fundamental error has been made in following through the problem with the units and this must be corrected.

The more difficult task is to recognize when the magnitude of an answer is wrong; i.e., is not "in the right ballpark". If we are told that the speed of a car is 92 meters/sec. or is 125 ft/sec. do we have any "feel" for whether these are reasonable or not? Is this car speeding or not? Most of us don't have a clue without doing some quick calculations (these are 205 mph and 85 mph, respectively). Do any of us know our weight in Newtons? What is a reasonable barometric pressure in the atmosphere in any unit system?

So our second unit related task is to develop some appreciation for the "normal" range of magnitudes for the things we want to calculate in our chosen units system(s). What is a reasonable range for a wing's lift coefficient or drag coefficient? Is it reasonable for cars to have 10 times the drag coefficient of airplanes?

With these cautions in mind let's go back and look at our "working medium", the standard atmosphere.

1.4 The Standard Atmosphere

We said we were starting with the Ideal Gas Equation of State, $P=RT$. We will also make use of the **Hydrostatic Equation**, another relationship you have seen before in chemistry and physics:

$$\Delta P = -\rho g \Delta h$$

This tells us how pressure changes with height in a column of fluid. This tells us how pressure changes as we move up or down through the atmosphere.

These two equations, the Perfect Gas Equation of State and the Hydrostatic Equation, have three variables in them; pressure, density, and temperature. To solve for these properties at any point in the atmosphere requires us to have one more equation, one involving temperature. This is going to require our **first assumption**. We must have some relationship that can tell us how temperature should vary with altitude in the atmosphere.

Many years of measurement and observation have shown that, in general, the lower portion of the atmosphere, where most airplanes fly, can be modeled in two segments, the **Troposphere** and the **Stratosphere**. The temperature in the troposphere is found to drop fairly linearly as altitude increases. This linear decrease in temperature continues up to about 36,000 feet (about 11,000 meters). Above this altitude the temperature is found to hold constant up to altitudes over 100,000 ft. This constant temperature region is the lower part of the **Stratosphere**. The troposphere and stratosphere are where airplanes operate, so we need to look at these in detail.

1.5 The Troposphere

We model the linear temperature drop with altitude in the troposphere with a simple equation:

$$T_{\text{alt}} = T_{\text{sealevel}} - Lh$$

where "L" is called the "lapse rate". From over a hundred years of measurements it has been found that a normal, average lapse rate is:

$$L = 3.56^{\circ}\text{R} / 1000 \text{ ft} = 6.5^{\circ}\text{K} / 1000 \text{ meters} .$$

This is often taught to pilots in a strange mixture of units as 1.98 degrees Centigrade per thousand feet!

The other thing we need is a value for the sea level temperature. Our model, also based on averages from years of measurement, uses the following sea level values for pressure, density, and temperature.

$$P_{SL} = 1.013 \times 10^5 \text{ Pascals} = 2116 \text{ lb/ft}^2$$

$$\rho_{SL} = 1.23 \text{ kg/m}^3 = 0.002378 \text{ sl/ft}^3$$

$$T_{SL} = 288 \text{ }^\circ\text{K} = 520 \text{ }^\circ\text{R}$$

So, to find temperature at any point in the troposphere we use:

$$T \text{ (}^\circ\text{R)} = 520 - 3.56(h),$$

where h is the altitude *in thousands of feet*, or

$$T \text{ (}^\circ\text{K)} = 288 - 6.5 (h)$$

where h is the altitude in thousands of meters.

We need to stress at this point that this temperature model for the Troposphere is merely a model, but it is the model that everyone in the aviation and aerospace community has agreed to accept and use. The chance of ever going to the seashore and measuring a temperature of 59°F is slim and even if we find that temperature it will surely change within a few minutes. Likewise, if we were to send a thermometer up in a balloon on any given day the chance of finding a “lapse rate” equal to the one defined as “standard” is slim to none, and, during the passage of a weather front, we may even find that temperature increases rather than drops as we move to higher altitudes. Nonetheless, we will work with this model and perhaps later learn to make corrections for non-standard days.

Now, if we are willing to accept the model above for temperature change in the Troposphere, all we have to do is find relationships to tell how the other properties, pressure and density, change with altitude in the Troposphere. We start with the differential form of the hydrostatic equation and combine it with the Perfect Gas equation to eliminate the density term.

$$dP = -\rho g dh, P = \rho RT$$

or,

$$dP/dh = -\rho g = -(P/RT)g$$

which is rearranged to give

$$dP/P = -(g/RT)dh.$$

Now we substitute in the lapse rate relationship for the temperature to get

$$dP/P = \{g/[R(T_{SL}-Lh)]\}dh.$$

This is now a relationship with only one variable (P) on the left and only one (h) on the right. It can be integrated to give

$$P_{alt}/P_{SL} = [T_{alt}/T_{SL}]^{g/LR}$$

In a similar manner we can get a relationship to find the density at any altitude in the troposphere

$$\rho_{alt}/\rho_{SL} = [T_{alt}/T_{SL}]^{(g-LR)/LR}$$

So now we have equations to find pressure, density, and temperature at any altitude in the troposphere. Care has to be taken with units when using these equations. All temperatures must be in absolute values (Kelvin or Rankine instead of Celsius or Fahrenheit).

The exponents in the pressure and density ratio equations must be unitless. Exponents cannot have units!

We can use these equations up to the top of the Troposphere, that is, up to 11,000 meters or 36,100 feet in altitude. Above that altitude is the Stratosphere where temperature is modeled as being constant up to roughly 100,000 feet.

1.6 The Stratosphere

We can use the temperature lapse rate equation result at 11,000 meters altitude to find the temperature in this part of the Stratosphere.

$$T_{\text{stratosphere}} = 216.5^\circ\text{K} = 389.99^\circ\text{R} = \text{constant}$$

The equations for determining the pressure and density in the constant temperature part of the stratosphere are different from those in the troposphere since temperature is constant. And, since temperature is constant both pressure and density vary in the same manner.

$$P_2/P_1 = \rho_2/\rho_1 = e^{g(h_1 - h_2)/RT}$$

The term on the right in the equation is “e” or 2.718, evaluated to the power shown, where h_1 is the 11,000 meters or 36,100 ft (depending on the unit system used) and h_2 is the altitude where the pressure or density is to be calculated. T is the temperature in the stratosphere.

Using the above equations we can find the pressure, temperature, or density anywhere an airplane might fly. It is common to tabulate this information into a standard atmosphere table. Most such tables also include the speed of sound and the air viscosity, both of which are functions of temperature. Tables in both SI and English units are given below.

Table 1.1: Standard Atmosphere in SI Units

h (km)	T (degrees C)	a (m / sec)	$P \times 10^{-4} (\text{N/m}^2)$ (pascals)	P (kg/m ³)	$u \times 10^5$ (kg/m sec)
0	15	340	10.132	1.226	1.78
1	8.5	336	8.987	1.112	1.749
2	2	332	7.948	1.007	1.717
3	-4.5	329	7.01	0.909	1.684
4	-11	325	6.163	0.82	1.652
5	-17.5	320	5.4	0.737	1.619
6	-24	316	4.717	0.66	1.586
7	-30.5	312	4.104	0.589	1.552
8	-37	308	3.558	0.526	1.517
9	-43.5	304	3.073	0.467	1.482
10	-50	299	2.642	0.413	1.447
11	-56.5	295	2.261	0.364	1.418
12	-56.5	295	1.932	0.311	1.418
13	-56.5	295	1.65	0.265	1.418
14	-56.5	295	1.409	0.227	1.418
15	-56.5	295	1.203	0.194	1.418
16	-56.5	295	1.027	0.163	1.418
17	-56.5	295	0.785	0.141	1.418
18	-56.5	295	0.749	0.121	1.418
19	-56.5	295	0.64	0.103	1.418
20	-56.5	295	0.546	0.088	1.418
30	-56.5	295	0.117	0.019	1.418
45	40	355	0.017	0.002	1.912
60	70.8	372	0.003	0.00039	2.047
75	-10	325	0.0006	0.00008	1.667

Table 1.2: Standard Atmosphere in English Units

h (ft)	T (degrees F)	a (ft/sec)	p (lb/ft ²)	p (slugs/ft ³)	u x 10 ⁷ (sl/ft-sec)
0	59	1117	2116.2	0.002378	3.719
1,000	57.44	1113	2040.9	0.00231	3.699
2,000	51.87	1109	1967.7	0.002242	3.679
3,000	48.31	1105	1896.7	0.002177	3.659
4,000	44.74	1102	1827.7	0.002112	3.639
5,000	41.18	1098	1760.8	0.002049	3.618
6,000	37.62	1094	1696	0.001988	3.598
7,000	34.05	1090	1633	0.001928	3.577
8,000	30.49	1086	1571.9	0.001869	3.557
9,000	26.92	1082	1512.9	0.001812	3.536
10,000	23.36	1078	1455.4	0.001756	3.515
11,000	19.8	1074	1399.8	0.001702	3.495
12,000	16.23	1070	1345.9	0.001649	3.474
13,000	12.67	1066	1293.7	0.001597	3.453
14,000	9.1	1062	1243.2	0.001546	3.432
15,000	5.54	1058	1194.3	0.001497	3.411
16,000	1.98	1054	1147	0.001448	3.39
17,000	-1.59	1050	1101.1	0.001401	3.369
18,000	-5.15	1046	1056.9	0.001355	3.347
19,000	-8.72	1041	1014	0.001311	3.326
20,000	-12.28	1037	972.6	0.001267	3.305
21,000	-15.84	1033	932.5	0.001225	3.283
22,000	-19.41	1029	893.8	0.001183	3.262
23,000	-22.97	1025	856.4	0.001143	3.24
24,000	-26.54	1021	820.3	0.001104	3.218
25,000	-30.1	1017	785.3	0.001066	3.196
26,000	-33.66	1012	751.7	0.001029	3.174
27,000	-37.23	1008	719.2	0.000993	3.153
28,000	-40.79	1004	687.9	0.000957	3.13
29,000	-44.36	999	657.6	0.000923	3.108
30,000	-47.92	995	628.5	0.00089	3.086
31,000	-51.48	991	600.4	0.000858	3.064
32,000	-55.05	987	573.3	0.000826	3.041

h (ft)	T (degrees F)	a (ft/sec)	p (lb/ft ²)	p (slugs/ft ³)	$\mu \times 10^7$ (sl/ft-sec)
33,000	-58.61	982	547.3	0.000796	3.019
34,000	-62.18	978	522.2	0.000766	2.997
35,000	-65.74	973	498	0.000737	2.974
40,000	-67.6	971	391.8	0.0005857	2.961
45,000	-67.6	971	308	0.0004605	2.961
50,000	-67.6	971	242.2	0.0003622	2.961

Table 1.2: Standard Atmosphere in English Units (con't)

h (ft)	T (degrees F)	a (ft/sec)	p (lb/ft ²)	p (slugs/ft ³)	$\mu \times 10^7$ (sl/ft-sec)
60,000	-67.6	971	150.9	0.000224	2.961
70,000	-67.6	971	93.5	0.0001389	2.961
80,000	-67.6	971	58	0.0000861	2.961
90,000	-67.6	971	36	0.0000535	2.961
100,000	-67.6	971	22.4	0.0000331	2.961
150,000	113.5	1174	3.003	0.00000305	4.032
200,000	159.4	1220	0.6645	0.00000062	4.277
250,000	-8.2	1042	0.1139	0.00000015	3.333

A look at these tables will show a couple of terms that we have not discussed. These are the speed of sound “a”, and viscosity “ μ ”. The speed of sound is a function of temperature and decreases as temperature decreases in the Troposphere. Viscosity is also a function of temperature.

The speed of sound is a measure of the “compressibility” of a fluid. Water is fairly incompressible but air can be compressed as it might be in a piston/cylinder system. The speed of sound is essentially a measure of how fast a sound or compression wave can move through a fluid. We often talk about the speeds of high speed aircraft in terms of Mach number where Mach number is the relationship between the speed of flight and the speed of sound. As we get closer to the speed of sound (Mach One) the air becomes more compressible and it becomes more meaningful to write many equations that describe the flow in terms of Mach number rather than in terms of speed.

Viscosity is a measure of the degree to which molecules of the fluid bump into each other and transfer forces on a microscopic level. This becomes a measure of “friction” within a fluid and is an important term when looking at friction drag, the drag due to shear forces that occur when a fluid (air in our case) moves over the surface of a wing or body in the flow.

Two things should be noted in these tables about viscosity. First, the units look sort of strange. Second, the viscosity column is headed with $\mu \times 10^x$. The units are the proper ones for viscosity in the SI and English systems respectively; however, if you talk to a chemist or physicist about viscosity they will probably quote numbers with units of “poise”. **The 10^x number in the column heading means that the number shown in the column has been multiplied by 10^x to give it the value shown.** This is, to most of us, not intuitive. What this means is that in the English unit version of the Standard Atmosphere table, the viscosity at sea level has a value of 3.719 times ten to the **minus 7**.

So now we can find the properties of air at any altitude in our model or “standard” atmosphere. However, this is just a model, and it would be rare indeed to find a day when the atmosphere actually matches our model. Just how useful is this?

In reality this model is pretty good when it comes to pressure variation in the atmosphere because it is based on the hydrostatic equation which is physically correct. On the other hand, pressure at sea level does vary from day to day with weather changes, as the area of concern comes under the various high or low pressure systems often noted on weather maps. Temperature represents the greatest opportunity for variation between the model and the real atmosphere, after all, how many days a year is the temperature at the beach 59°F (520°R)? Density, of course, is a function of pressure and temperature, so its “correctness” is dependent on that of P and T.

On the face of things, it appears that the Standard Atmosphere is somewhat of a fantasy. On the other hand, it does give us a pretty good idea of how these properties of air should normally change with altitude. And, we can possibly make corrections to answers found when using this model by correcting for actual sea level pressure and temperature if needed. Further, we could define other “standard” atmospheres if we are looking at flight conditions where conditions are exceptionally different from this model. This is done to give “Arctic Minimum” and “Tropical Maximum” atmosphere models.

In the end, we do all aircraft performance and aerodynamic calculations based on the normal standard atmosphere and all flight testing is done at standard atmosphere pressure conditions to define altitudes. The standard atmosphere is our model and it turns out that this model serves us well.

One way we use this model is to determine our altitude in flight.

1.7 Altitude Measurement

The pilot of an aircraft needs to know its altitude and there are several ways we could measure the altitude of an airplane. Radar might be used to measure the plane’s distance above the ground. Global Positioning System satellite signals can determine the plane’s position, including its altitude, in three dimensional space. These and some other possible methods of altitude determination depend on the operation of one or more electrical systems, and while we may want to have such an instrument on our airplane, we also are required to have an “altimeter” that does not depend on batteries or generators for its operation. Further, the altitude that the pilot needs to know is the height above sea level. The obvious solution is to use our knowledge that the pressure varies in a fairly dependable fashion with altitude.

If we know how pressure varies with altitude then we can measure that pressure and determine the altitude above a sea level reference point. In other words, if we measure the pressure as 836 pounds per square foot we can look in the standard atmosphere table and find that we should be at an altitude of 23,000 ft. So all we need to do is build a simple mechanical barometer and calibrate its dial so it reads in units of altitude rather than pressure. As the measured pressure decreases, the indicated altitude increases in accord with the standard atmosphere model. This is, in fact, how “simple” altimeters such as those sometimes used in cars or bikes or even “ultra-lite” aircraft. A barometer measures the air pressure and on some type of dial or scale, instead of pressure units, the equivalent altitudes are indicated.

The “simple” altimeter, however, might not be quite accurate enough for most flying because of the variations in atmospheric pressure with weather system changes. The simple altimeter would base its reading on the assumption that the pressure at sea level is 2116 psf . If, however, we are in an area of “high” pressure, the altimeter of an airplane sitting at sea level would sense the higher than standard pressure and indicate an altitude somewhat below sea level. Conversely, in the vicinity of a low pressure atmospheric system the altimeter would read an altitude higher than the actual value. If this error was only a few feet it might not matter, but in reality it could result in errors of several hundred feet in altitude readings. This could lead to disaster in bad weather when a pilot has to rely on the altimeter to ensure that the plane clears mountain peaks or approaches the runway at the right altitude. Hence, all aircraft today use “sensitive” altimeters that allow the pilot to adjust the instrument for changes in pressure due to atmospheric weather patterns.

The sensitive altimeter, shown in the next figure, has a knob that can be turned to adjust the readout of the instrument for non-standard sea level pressures. This can be used in two different ways in flight. When the aircraft is sitting on the ground at an airport the pilot can simply adjust the knob until the altimeter reads the known altitude of the airport. In flight, the pilot can listen to weather report updates from nearby airports, reports that will include the current sea level equivalent barometric pressure, and turn the knob until the numbers in a small window on the altimeter face agree with the stated pressure. These readings are usually given in units of millimeters of mercury where 29.92 is sea level standard. Adjusting the reading in the window to a higher pressure will result in a decrease in the altimeter reading and adjusting it lower will increase the altitude indication. With proper and timely use of this adjustment a good altimeter should be accurate within about 50 feet.

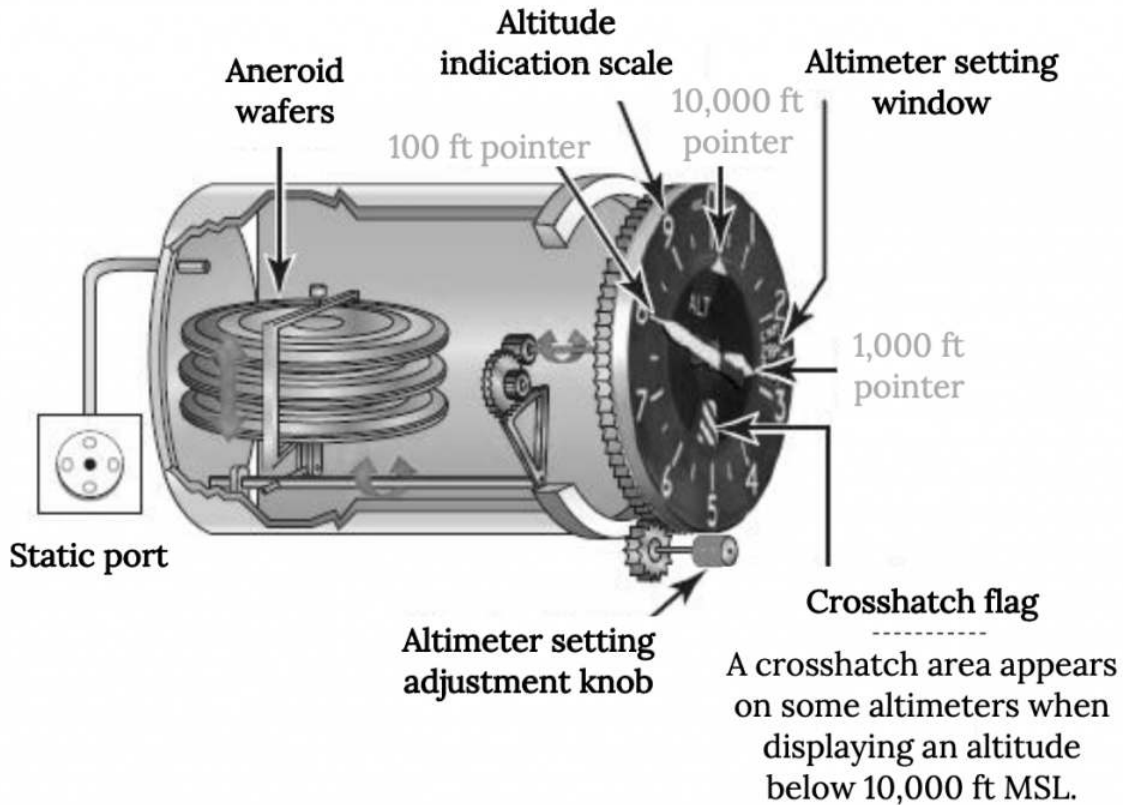

Figure 1.4: A Typical Mechanical Sensitive Altimeter

It should be noted that we could also use density to define our altitude and, in fact, this might prove more meaningful in terms of relating to changes in an airplane's performance at various flight altitudes because engine thrust and power are known to be functions of density and the aerodynamic lift and drag are also functions of density. However, to "measure" density would require measurement of both pressure and temperature. This could introduce more error into our use of the standard atmosphere for altitude determination than the use of pressure alone because temperature variation is much more subject to non-standard behavior than that of pressure. On the other hand, we do sometimes find it valuable to calculate our "density altitude" when looking at a plane's ability to take-off in a given ground distance.

If we are at an airport which is at an altitude of, lets say, 4000 ft and the temperature is higher than the 44.74°F predicted by the standard atmosphere (as it probably would be in the summer) we would find that the airplane behaves as if it is at a higher altitude and will take a longer distance to become airborne than it should at 4000 ft. Pilots use either a circular slide rule type calculator or a special electronic calculator to take the measured real temperature and combine it with the pressure altitude to find the "density altitude", and this can be used to estimate the extra takeoff distance needed relative to standard conditions.

Some may wonder why we can't simply use temperature to find our altitude. After all, wasn't one of our basic assumptions that in the Troposphere, temperature dropped linearly with altitude? Wouldn't it be really easy to stick a thermometer out the window and compare its reading with a standard atmosphere chart to find our altitude?

Of course, once we are above the Troposphere this wouldn't do any good since the temperature becomes constant over thousands of feet of altitude, but why wouldn't it work in the Troposphere?

Thought Exercise

- Think about and discuss why using temperature to find altitude is not a good idea.
- Why is pressure the best property to measure to find our altitude?
- Perhaps using density to find altitude would be a better idea since density has a direct effect on flight performance. Think of one reason why we don't have altimeters that measure air density.

1.8 Bernoulli's Equation

You have undoubtedly been introduced to a relationship called **Bernoulli's Equation** or the **Bernoulli Principle** somewhere in a previous Physics or Chemistry course. This is the principle that relates the pressure to the velocity in any fluid, essentially showing that as the speed of a fluid increases its pressure decreases and visa versa. This principle can take several different mathematical forms depending on the fluid and its speed. For an **incompressible** fluid such as water or for air below about 75% of the speed of sound this relationship takes the following form:

$$P + \frac{1}{2}\rho V^2 = P_0$$

(hydro)static pressure + dynamic pressure = total pressure

[internal energy + kinetic energy = total energy]

This relationship can be thought of as either a measure of the balance of pressure forces in a flow, or as an energy balance (first law of thermodynamics) when there is no change in potential energy or heat transfer.

Bernoulli's equation says that along any continuous path ("streamline") in a flow the total pressure, P_0 , (or total energy) is conserved (constant) and is a sum of the static pressure and the dynamic pressure in the flow. Static pressure and dynamic pressure can both change, but they must change in such a way that their sum is constant; i.e., as the flow speeds up the pressure decreases.

*** ASSUMPTIONS:** It is very important that we know and understand the assumptions that limit the use of this form of Bernoulli's equation. The equation can be derived from either the first law of thermodynamics (energy conservation) or from a balance of forces in a fluid through what is known as Euler's Equation. In deriving the form of the equation above some assumptions are made in order to make some of the math simpler. These involve things like assuming that density is a constant, making it a constant in an integration step in the derivation and making the integration easier. It is also assumed that mass is conserved, a seemingly logical assumption, but one that has certain consequences in the use of the equation. It is also assumed that the flow is "steady", that is, the speed at any point in the flow is not varying with time. Another way to put this is that the speed can vary with position in the flow (that's really what the equation is all about) but cannot vary with time.

The assumption of **constant density**, which we usually call an assumption of **incompressible flow**, means that we have to observe a **speed limit**. As air speeds up and the speed approaches the speed of sound its density changes; i.e., it becomes compressible. So when our flow speeds get too near the speed of sound, the incompressible flow assumption is violated and we can no longer use this form of Bernoulli's equation. When does that become a problem?

Some fluid mechanics textbooks use a mathematical series relationship to look at the relationship between speed or Mach number (Mach number, the speed divided by the speed of sound, is really a better measure of compressibility than speed alone) and they use this to show that the incompressible flow assumption is not valid above a Mach number of about 0.3 or 0.3 times the speed of sound. This is good math but not so good physics. The important thing is not how the math works but how the relationship between the two pressures in Bernoulli's equation changes as speed or Mach number increases. We will examine this in a later example to show that we are actually pretty safe in using the incompressible form of Bernoulli's equation up to something like 75% of the speed of sound.

The other important assumptions in this form of Bernoulli's equation are those of steady flow and mass conservation. Steady flow means pretty much what it sounds like; the equation is only able to account for changes in speed and pressure with position in a flow field. It was assumed that the flow is exactly the same at any time.

The mass conservation assumption really relates to looking at what are called "streamlines" in a flow. These can be thought of at a basic level as flow paths or highways that follow or outline the movement of the flow. Mass conservation implies that at any point along those paths or between any two streamlines the mass flow between the streamlines (in the path) is the same as it is at any other point between the same two streamlines (or along the same path).

The end result of this mass conservation assumption is that Bernoulli's equation is only guaranteed to hold true along a streamline or path in a flow. However, we can extend the use of the relationship to any point in the flow if all the flow along all the streamlines (or paths) at some reference point upstream (at " ∞ ") has the same total energy or total pressure.

So, we can use Bernoulli's equation to explain how a wing can produce lift. If the flow over the top of the wing is faster than that over the bottom, the pressure on the top will be less than that on the bottom and the resulting pressure difference will produce a lift.

The study of aerodynamics is really all about predicting such changes in velocity and pressure around various shapes of wings and bodies. Aerodynamicists write equations to describe the way air speeds change around prescribed shapes and then combine these with Bernoulli's equation to find the resulting pressures and forces.

Let's look at the use of Bernoulli's equation for the case shown below of a wing moving through the air at 100 meters/sec. at an altitude of 1km.

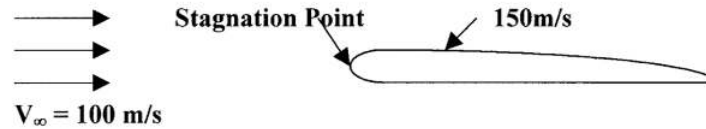

Figure 1.5: Bernoulli's Equation Example

We want to find the pressure at the leading edge of the wing where the flow comes to rest (the **stagnation point**) and at a point over the wing where the speed has accelerated to 150 m/s.

First, note that the case of the wing moving through the air has been portrayed as one of a stationary wing with the air moving past it at the desired speed. This is standard procedure in working aerodynamics problems and it can be shown that the answers one finds using this method are the correct ones. Essentially, since the process of using Bernoulli's equation is one of looking at conservation of energy, it doesn't matter whether we are analyzing the motion (kinetic energy) involved as being motion of the body or motion of the fluid.

Now let's think about the problem presented above. We know something about the flow at three points:

Well in front of the wing we have what is called "**free stream**" or undisturbed, uniform flow. We designate properties in this flow with an infinity [∞] subscript. We can write Bernoulli's equation here as:

$$P_{\infty} + (1/2)\rho V_{\infty}^2 = P_0$$

where $V_{\infty} = 100\text{m/s}$

Note that it is at this point, the "free stream" where all the flow is uniform and has the same total energy. If at this point the flow was not uniform, perhaps because it was near the ground and the speed increases with distance up from the ground, we could not assume that each "streamline" had a different value of total pressure (energy).

At the front of the wing we will have a point where the flow will come to rest. We call this point the "stagnation point" if we can assume that the flow slowed down and stopped without significant losses. Here the flow speed would be zero. We can write Bernoulli's equation here as:

$$P_{\text{stagnation}} + 0 = P_0$$

At this point the flow has accelerated to 150 m/s and we can write Bernoulli's equation as:

$$P_3 + (1/2)\rho V_3^2 = P_0$$

where $V_3 = 150\text{m/s}$

Now we know that since the flow over the wing is continuous (mass is conserved) the **total pressure (P_0)** is the same at all three points and this is what we use to find the missing information. To do this we must understand which of these pressures (if any) are known to us as atmospheric hydrostatic pressures and understand that we can assume that the density is constant as long as we are safely below the speed of sound.

Initially we know that the pressure in the atmosphere is that in the standard atmosphere table for an altitude of 1 km or 89870 Pascals and that the density at this altitude is 1.112 kg/m^3 . Looking at the problem, the most logical place for standard atmosphere conditions to apply is in the "free stream" location because this is where the undisturbed flow exists. Hence

$$P_{\infty} = 89870\text{Pa}, \quad \rho = \text{constant} = 1.112\text{kg/m}^3, \quad V_{\infty} = 100\text{m/s}$$

And, using these in Bernoulli's equation at the free stream location we calculate a total pressure

$$P_0 = 95430\text{ Pa}$$

Now that we have found the total pressure we can use it at any other location in the flow to find the other unknown properties.

At the stagnation point

$$P_{\text{stagnation}} = P_0 = 95430 \text{ Pa}$$

At the point where the speed is 150 m/s we can rearrange Bernoulli's equation to find

$$P_3 = P_0 - (1/2)\rho V_3^2 = 82920 \text{ Pa}$$

As a check we should confirm that the static pressure (P_3) at this point is less than the free stream static pressure (P) since the speed is higher here and also confirm that the static pressures everywhere else in the flow are lower than the stagnation pressure.

Now let's review the steps in working any problem with Bernoulli's equation. *First* we must sketch the flow and write down everything we know at various points in that flow. *Second* we must write Bernoulli's equation at every point in the flow where we either know information or want to know something. *Third* we must carefully assess which pressure, if any, can be obtained from the standard atmosphere table. *Fourth* we must look at all these points in the flow and see which point gives us enough information to solve for the total pressure (P_0). *Finally* we use this value of P_0 in Bernoulli's equation at other points in the flow to find the other missing terms. Attempting to skip any of the above steps can lead to mistakes for most of us.

One of the most common problems that people have in working with Bernoulli's equation in a problem like the one above is to assume that the stagnation point is the place to start the solution of the problem. They look at the three points in the flow and assume that the stagnation point must be the place where everything is known. After all, isn't the velocity at the stagnation point equal to zero? Doesn't this mean that the static pressure and the total pressure are the same here? And what other conclusion can be drawn than to assume that this pressure must then be the atmospheric pressure?

*Well, the answer to the first two questions is "yes" but a third "yes" does not follow. What is known at the stagnation point is that the static pressure term in the equation is now the static pressure at a stagnation point and is therefore called the stagnation pressure. And, since the speed is zero, the stagnation pressure is equal to the total pressure in the flow. **Neither of these pressures, however, is the atmospheric pressure.***

*Why is the pressure at the stagnation point not the pressure in the atmosphere? Well, this is where our substitution of a moving flow and a stationary wing for a moving wing in a stationary fluid ends up causing us some confusion. In reality, **this stagnation point is where the wing is colliding head-on with the air that it is rushing through. The pressure here, the stagnation pressure, must be equal to the pressure in the atmosphere plus the pressure caused by the collision between wing and fluid; i.e., it must be higher than the atmospheric pressure.***

Our approach of modeling the flow of a wing moving through the stationary atmosphere as a moving flow around a stationary wing makes it easier to work with Bernoulli's equation in general; however, we must keep in mind that it is a substitute model and alter our way of looking at it appropriately. In this model the hydrostatic pressure is not the pressure where the air is "static", it is, rather, the pressure where the flow is "undisturbed". This is at the "free stream" conditions, the point upstream of the body (wing, in this case) where the flow has not yet felt the presence of the wing. This is where the undisturbed atmosphere exists. Between that point and the wing itself the flow has to change direction and speed as it moves around the body, so nowhere else in the flow field will the pressure be the same as in the undisturbed atmosphere.

1.9 Airspeed Measurement

Now that we know something about Bernoulli's equation we can look at another use of the relationship, the *measurement of airspeed*. Rearranging the equation we can write:

$$V = [2(P_0 - P) / \rho]^{1/2}$$

So, if we know the total and static pressures at a point and the density at that point we can easily find the speed at that point. All we need is some way to measure or otherwise find these quantities.

We can find the total pressure (P_0) by simply inserting an open tube of some kind into the flow so that it is pointed into the oncoming flow and then connected to a pressure gage of some sort.

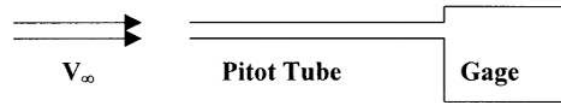

Figure 1.6: A Pitot Tube Measures Total Pressure

The static pressure can be found in a similar manner but the flow must be going parallel to the openings in the tube or surface.

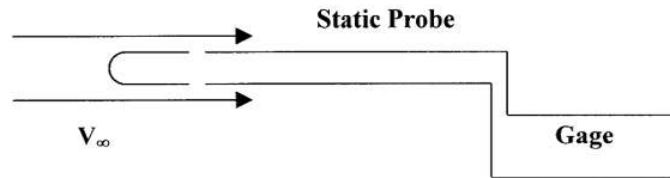

Figure 1.7: A Static Tube Measures Static Pressure

On an airplane we usually mount a *pitot tube* somewhere on the wing or nose of the aircraft where it will generally point into the undisturbed flow and not be behind a propeller. The *static pressure* reading on an airplane is normally taken via a hole placed at some point on the side of the airplane where the flow will have the same static pressure as the freestream flow instead of using a separate static probe. This point is usually determined in flight testing. There is usually a *static port* on both sides of the plane connected to a single tube through a “T” connection. The static port looks like a small, circular plate with a hole in its center. One of the jobs required of the pilot in his or her preflight inspection of the aircraft is to make sure that both the pitot tube and static ports are free of obstruction, a particularly important task in the Spring of the year when insects like to crawl into small holes and build nests.

In a wind tunnel and in other experimental applications we often use a single instrument to measure both total and static pressures. This instrument is called a *pitot-static tube* and it is merely a combination of the two probes shown above.

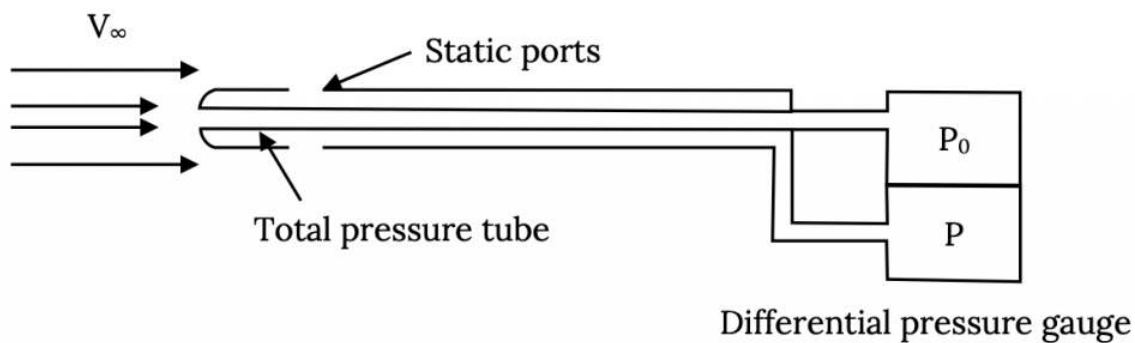

Figure 1.8: A Pitot-Static Probe

In both the lab case and the aircraft case it is the difference in the two pressures, $P_0 - P$, that we want to know and this can be measured with several different types of devices ranging from a “U-tube” liquid manometer to a sophisticated electronic gage. In an aircraft, where we don’t want our knowledge of airspeed to depend on a source of electricity and where a liquid manometer would be cumbersome, the pressure difference is measured by a mechanical device called an aneroid barometer.

But let’s go back and look at the equation used to find the velocity and see if this causes any problem.

$$V = [2(P_0 - P) / \rho]^{1/2}$$

This shows that we also need to know the density if we wish to find the speed. In the lab we find the density easily enough by measuring the barometric pressure and the temperature and calculating density using the Ideal Gas Law,

$$P = \rho RT$$

or,

$$\rho = P/RT$$

and, using this we can find the exact or “true” airspeed.

In an airplane we want simplicity and reliability, and while we could ask the pilot or some flight computer to measure pressure and temperature, then calculate density, then put it into Bernoulli’s equation to calculate airspeed, this seems a little burdensome and, of course, the use of computers or calculators might depend on electricity. Hence, we do not usually have an instrument on an aircraft that displays the true airspeed; instead we choose to simply measure the difference in the two above pressures using a mechanical instrument and then calibrate that instrument to display what we call the **indicated airspeed**, a measurement of speed based on the assumption of **sea level density**.

$$V_{\text{ind}} = [2(P_0 - P) / \rho_{\text{SL}}]^{1/2}$$

Another name for the **indicated airspeed** is the “**sea level equivalent airspeed**”, the speed which would exist for the measured difference in static and total pressure if the aircraft was at sea level.

The true and indicated airspeeds are directly related by the square root of the ratio of sea level and true densities.

$$V_{\text{true}} = V_{\text{ind}}[\rho_{\text{SL}}/\rho_{\text{alt}}]^{1/2}$$

The **airspeed indicator** on an aircraft then measures the **indicated airspeed** and not the true airspeed. It is a sealed instrument with the static pressure going to the instrument container and the total pressure connected to an aneroid barometer inside the container. As the difference in these two pressures changes, the indicator needles on the instrument face move over a dial marked off, not for a range of pressures, but for a range of speeds. Each such instrument is carefully calibrated to ensure accurate measurement of indicated airspeed.

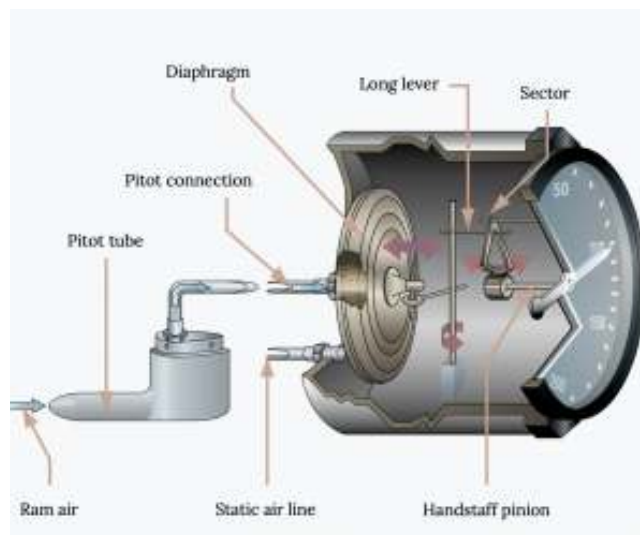

Figure 1.9: An Airspeed Indicator

So, just as we found that the altimeter on an airplane measures the wrong altitude unless we are able to adjust it properly, the airspeed indicator does not measure the real airspeed. Is this a problem for us?

It turns out that, as far as the performance of the aircraft is concerned; i.e., its ability to take off in a certain distance, to climb at a certain rate, etc., is actually dependent on the indicated airspeed rather than the true airspeed. Yes, we want to know the true airspeed to know how fast we are really going and for related flight planning purposes, but as far as knowing the speed at which to rotate on takeoff, the best speed at which to climb or glide, and so on, we are better off using the indicated airspeed.

The indicated airspeed, since the density is assumed to always be sea level conditions, is really a function only of the difference in total and static pressures, $P_0 - P$, which we know from Bernoulli’s equation is equal to:

$$P_0 - P = 1/2\rho V^2 = 1/2\rho_{\text{SL}} V_{\text{ind}}^2 = 1/2\rho_{\text{alt}} V_{\infty}^2$$

and we are going to find that the terms on the right, the dynamic pressure, is a very important term in accounting for the forces on a body in a fluid. In other words, the plane's behavior in flight is much more dependent on the dynamic pressure than on the airspeed alone.

Example: Let's look at the difference between true and indicated airspeed just to get some idea of how big this difference might be. Lets pick an altitude of 15,000 feet and see what the two values of airspeed would be if the pitot-static system is exposed to a pressure difference of 300 pounds-per-square-foot (psf). The density in the standard atmosphere for 15,000 feet is 0.001497 sl/ft³ while that at sea level is 0.002378 sl/ft³.

$$V_{\text{ind}} = [2(P_0 - P) / \rho_{\text{SL}}]^{1/2} = 502 \text{ ft/sec}$$

$$V_{\text{true}} = V_{\text{ind}} [\rho_{\text{SL}} / \rho_{\text{alt}}]^{1/2} = 633 \text{ ft/sec.}$$

So the difference in these two readings can be significant, but that is OK. We use the indicated airspeed to fly the airplane and use the true airspeed when finding the time for the trip. Note that **when working Bernoulli's equation problems**, such as in finding the variations in pressures and velocity around a wing, **you always want to use the true airspeed and the real pressures and density at altitude.**

Finally, while on the subject of airspeed, we should note that even though we often calculate the speed of an aircraft or wing in units of feet/sec. or meters/sec., most airspeed indicators will show the airspeed in units of either miles-per-hour or **knots**. The knot is a rather ancient unit of speed used for centuries by sailors and once measured by timing a knotted rope as it was lowered over the side of a ship into the flowing sea.

A **knot** is a **nautical-mile-per-hour** and a **nautical mile** is a set fraction of the earth's circumference. In relationship to more familiar English units:

$$1 \text{ knot (kt)} = 1.15 \text{ mph}$$

$$1 \text{ nautical mile (nm)} = 1.15 \text{ "statute" miles (mi).}$$

It is common practice in all parts of the world for our politically correct unit systems to be totally ignored and to do all flight planning and flying using units of *knots* and *nautical miles* for speed and distance.

1.10 Bernoulli's Equation for Compressible Flow

The form of Bernoulli's equation that we have been using is for *incompressible flow* as has been noted several times. **What if the flow isn't incompressible?**

If Bernoulli's equation was derived without making the assumption of constant air density it would come out in a different form and would be a relationship between pressures and Mach number. The relationship would also have another parameter in it, a term called *gamma* (γ). Gamma is simply a number for a given gas and the number depends on the number of atoms in the gas molecule, whether it is monatomic or diatomic, etc. Air is really a mixture of gasses but, in general, it is considered a diatomic gas. Its value of gamma is 1.4.

[Another name for gamma is the "ratio of specific heats" or the specific heat at constant pressure divided by the specific heat at constant density. These specific heats are a measure of the way heat is transferred in a gas under certain constraints (constant pressure or density) and this is, in turn, dependent on the molecular composition of the gas. In some other fields, Thermodynamics for example, the letter "k" is used for this ratio instead of γ .]

When a flow must be considered compressible this relationship between pressures and speed or Mach number takes the form below:

$$(P_0/P) = \{1 + [(\gamma-1)/2]M^2\}^{1/(\gamma-1)}$$

If you use both this equation and the incompressible form of Bernoulli's equation to solve for total pressure for given speeds from zero to 1000 ft/sec., using sea level conditions and the speed of sound at sea level to find the Mach number associated with each speed, and then compare the compressible and incompressible values of the total pressure (P_0) you will find just over 2% difference at 700 ft/sec. and 5% at 900 ft/sec. In other words, the use of Bernoulli's incompressible equation to find pressure and speed relationships is pretty reasonable up to speeds of about 75% of the speed of sound!

1.11 Forces in a Fluid

Above it was noted that the behavior of an airplane in flight is dependent on the dynamic pressure rather than on speed or velocity alone. In other words, it is a certain combination of density and velocity and not just density or velocity alone that is important to the way an airplane or a rocket flies. A question that might be asked is if there are other combinations of fluid properties that also have a major influence on aerodynamic forces.

We have already looked at one of these, Mach number, a combination of the speed and the speed of sound. *Why is Mach number a “unique” combination of properties? Are there others that are just as important?*

There is a fairly simple way we can take a look at how such combinations of fluid flow parameters group together to influence the forces and moments on a body in that flow. In more sophisticated texts this is found through a process known as “dimensional analysis”, and in books where the author was more intent on demonstrating his mathematical prowess than in teaching an understanding of physical reality, the process uses something called the “Buckingham-Pi Theorem”. Here, we will just be content with a description of the simplest process.

If we look at the properties in a fluid and elsewhere that cause forces on a body like an airplane in flight we could easily name several things like density, pressure, the size of the body, gravity, the “stickiness” or “viscosity” of the fluid and so on. As it turns out we could fairly easily say that most forces on an aircraft or rocket in flight are in some way functions of the following things:

$$\mathbf{F} = f(\rho, \mathbf{V}, l, \mu, \mathbf{P}, \mathbf{g}, \mathbf{a})$$

where,

ρ = density

\mathbf{V} = velocity

l = a representative length or size of the body

μ = viscosity

\mathbf{P} = pressure

\mathbf{g} = gravity (weight)

\mathbf{a} = speed of sound

Viscosity must be considered to account for friction between the flow and the body and the speed of sound is included because somewhere we have heard that there are things like large drag increases at speeds near the speed of sound.

We really don’t know at this point exactly how general to be in looking at these terms. For example, we already know from Bernoulli’s equation that it is velocity squared that is important and not just velocity, at least in some cases. And, we might expect that instead of length it is length squared (area) that is important in the production of forces since we know forces come from a pressure acting on an area. So let’s be completely general and say the following:

$$\mathbf{F} = f(\rho^A, \mathbf{V}^B, l^C, \mu^D, \mathbf{g}^E, \mathbf{P}^G, \mathbf{a}^H)$$

Our simple analysis does not seek to find exact relationships or numbers but only the correct functional dependencies or combination of parameters. The analysis is really just a matter of balancing the units on the two sides of the equation. On the left side we have units of force (pounds or Newtons) where we know that one pound is equal to one slug times one ft/sec.² or that one Newton is a kilogram-meter per second². So the combination of all the units inherent in all the terms on the right side of the equation must also come out in these exact same unit combination as found on the left side of the equation. In other words, when all the units are accounted for on the right hand side of the equation they must combine to have units of force;

$$(\text{sl})^1(\text{ft})^1(\text{sec})^{-2} \text{ or } (\text{mass})^1(\text{length})^1(\text{time})^{-2}.$$

So, in this game of dimensional analysis the procedure is to replace each physical term on both sides of the equation with its proper units. Then we can simply add up all the exponents on both sides and write equations relating unit powers. For example, on the left we have units of mass (slugs or kg) to the first power. On the right there are several terms that also have units of mass in them and their exponents must add up to match the one on the left.

$$\text{sl}^1 = (\text{sl}^A)(\text{sl}^D)(\text{sl}^G)$$

or since exponents add:

$$1 = A + D + G$$

We can do the same math for the other units of length and time and get two more relationships among the exponents:

$$1 = -3A + B + C - D + E - G + H$$

$$-2 = -B - D - 2E - 2G - H$$

These three equations of unit exponents can then be solved in terms of three of the “unknowns”, A, B, and C.

$$A = 1 - D - G$$

$$B = 2 - D - 2E - 2G - H$$

$$C = 2 - D + E$$

So, where we had density to the A power, or units of $(\text{sl}/\text{ft}^3)^A$, we now have:

$$(\text{sl}/\text{ft}^3)^A = (\text{sl})(\text{sl})^{-D}(\text{sl})^{-G}(\text{ft})^{-3D}(\text{ft})^{3D}(\text{ft})^{3G}.$$

We do this with every term on the right of the functional relationship and then rearrange the terms, grouping all terms with the same letter exponent and looking at the resulting groupings. We will get:

$$\mathbf{F} = \mathbf{f} \left[(\rho \mathbf{V}^2 \text{Area}) (\rho \mathbf{V} \text{ length}/\mu)^{-D} (\mathbf{g} \text{ length}/\mathbf{V}^2)^E (\mathbf{P}/\rho \mathbf{V}^2)^G (\mathbf{V}/a)^{-H} \right]$$

So, what does this tell us? It tells us that it is the groupings of flow and body parameters on the right that are important instead of the individual parameters in determining how a body behaves in a flow. Let’s examine each one.

The first term on the right is the only one that has no undefined exponent. The equation essentially says that **one** of the physical quantities that influences the production of forces on a body in a fluid is this combination of density, velocity squared, and some area (length squared).

If the force is a function of this combination of terms it is just as easily a function of this group divided by two; i.e.,

$$\mathbf{F} = \mathbf{f} (\rho \mathbf{V}^2 \mathbf{S}) = \mathbf{f} (1/2 \rho \mathbf{V}^2 \mathbf{S})$$

Note that we have used the letter “S” for the area. This may seem an odd choice since in other fields it is common to use S for a distance; however, it is conventional in aerodynamics to use **S** for a “**representative area**”. The area actually used is, as its name implies, one *representative of the aerodynamics of the body*. On an airplane, the dominant area for lift and drag is the wing, and S becomes the “**planform area**” of the wing. On a missile the frontal area is commonly used for S as is the case for automobiles and many other objects.

The second thing we note is that the term on the right is now the **dynamic pressure** times the representative area. So we have verified that the dynamic pressure is indeed very important in influencing the performance of a vehicle in a fluid.

If we look at this grouping of terms:

$$1/2 \rho \mathbf{V}^2 \mathbf{S}$$

we note that it has units of force (pressure times an area). This means that all the units on the right hand side of our equation are in this one term. The other combinations of parameters on the right side of our equation must be unitless. This is immediately obvious in one case, V/a, where both numerator and denominator are speeds and it can be verified in all the others by looking at their units. *We should recognize V/a as the Mach number!*

We now rewrite the equation:

$$\mathbf{F} / [1/2 \rho \mathbf{V}^2 \mathbf{S}] = \mathbf{f} \left[(\rho \mathbf{V} \text{ length}/\mu)^{-D} (\mathbf{g} \text{ length}/\mathbf{V}^2)^E (\mathbf{P}/\rho \mathbf{V}^2)^G (\mathbf{V}/a)^{-H} \right]$$

This says that the **unitless combination of terms on the left** is somehow a function of the four combinations of terms on the right. *What are these terms and what role do they play in the production of forces on a body in a fluid?*

1.12 Force Coefficients

First let's look at the term on the left. This unitless term tells us the proper way to “non-dimensionalize” fluid forces. Instead of talking about lift we will talk about a unitless **lift coefficient, C_L** :

$$C_L = L / [1/2\rho V^2 S]$$

We will also talk about a non-dimensional **drag coefficient, C_D** :

$$C_D = D / [1/2\rho V^2 S]$$

We use these **unitless “coefficients”** instead of the forces themselves for two reasons. First, they are nice because they are unitless and we don't need to worry about what unit system we are working in. If a wing has a lift coefficient of, say, 1.5, it will be 1.5 in either the English system or in SI or in any other system. Second, our analysis of units, this “dimensional analysis” business, has told us that it is more appropriate to the understanding of what happens to a body in a flow to look at lift coefficient and drag coefficient than it is to look just at lift and drag.

1.13 “Similarity Parameters”

Now, what about the terms on the right? Our analysis tells us that these groupings of parameters play an important role in the way force coefficients are produced in a fluid. Let's look at the simplest first, V/a .

V/a , by now, should be a familiar term to us. It is the ratio of the speed of the body in the fluid to the speed of sound in the fluid and it is called the **Mach Number**.

$$M = V/a .$$

If we are flying at the speed of sound we are at “Mach One” where $V = a$. But what is magic about Mach 1? There must be something important about it because back in the middle of the last century aerodynamicists were making a big deal about breaking the *sound barrier*; i.e., going faster than Mach 1. To see what the fuss was and continues to be all about let's look at what happens on a wing as it approaches the speed of sound.

As air moves over a wing it accelerates to speeds higher than the “free stream” speed. In other words, *at a speed somewhat less than the speed of sound, the speed on top of the wing may have reached speeds greater than the speed of sound*. This acceleration to supersonic speed does not cause any problem. *It is slowing the flow down again that is problematic*. Supersonic flow does not like to slow down and often when it does so it does it quite suddenly, through a “**shock wave**”. A shock wave is a sudden deceleration of a flow from supersonic to subsonic speed with an accompanying increase in pressure (remember Bernoulli's equation). This sudden pressure change can easily cause the flow over the wing to break away or **separate**, resulting in a large wake behind the wing and an accompanying high drag.

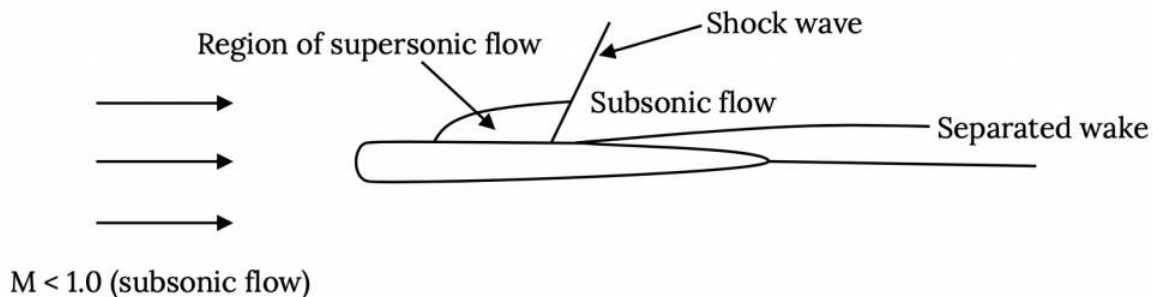

Figure 1.10: Shock Wave Formation in “Transonic” Flow

So at some high but subsonic speed (Mach number) supersonic flow over the wing has developed to the extent that a shock forms, and drag increases due to a separated wake and losses across the shock. The point where this begins to occur is called the **critical Mach number, M_{crit}** . M_{crit} will be different for each airfoil and wing shape. The result of all this is a drag coefficient behavior something like that shown in the plot below:

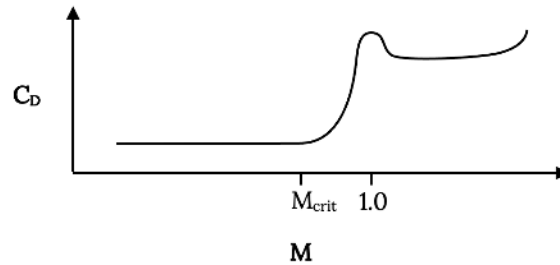

Figure 1.11: Drag Coefficient Increase Near Mach One

Actually the theory for subsonic, compressible flow says that the drag rise that begins at the critical Mach number climbs asymptotically at Mach 1; hence, the myth of the “sound barrier”. Unfortunately many people, particularly theoreticians, seemed to believe that reality had to fit their theory rather than the reverse, and thought that drag coefficient actually did become infinite at Mach 1. They had their beliefs reinforced when some high powered fighter aircraft in WWII had structural and other failures as they approached the speed of sound in dives. When the shock wave caused flow separation it changed the way lift and drag were produced by the wing, sometimes leading to structural failure on wings and tail surfaces that weren’t designed for those distributions of forces. This flow separation could also make control surfaces on the tail and wings useless or even cause them to “reverse” in their effectiveness. The pilot was left with an airplane which, if it stayed together structurally, often became impossible to control, leading to a crash. Sometimes, if the plane held together and the pilot could retain consciousness, the plane’s Mach number would decrease sufficiently as it reached lower altitude (the speed of sound is a function of temperature and is higher at lower altitude) and the problem would go away, allowing the pilot to live to tell the story.

At any rate, experimentalists came to the rescue, noting that bullets had for years gone faster than the speed of sound (“you’ll never hear the shot that kills you”) and designing a bullet shaped airplane, the Bell X-1, with enough thrust to get it to and past Mach 1.



Figure 1.12: The Bell X-1

Once the plane is actually supersonic, there are actually two shocks on the wing, one at the leading edge where the flow decelerates suddenly from supersonic freestream speed to subsonic as it reaches the stagnation point, and one at the rear where the supersonic flow over the wing decelerates again. As a result, the “sonic boom” one hears from an airplane at supersonic speeds is really two successive booms instead of a single bang.

So it is important that we be aware of the Mach number of a flow because the forces like drag can change dramatically as Mach number changes. We certainly don’t want to try to predict the forces on a supersonic aircraft from test results at subsonic speeds or vice-versa. On the other hand, as long as everything we are considering happens below the critical Mach number we may not need to worry about these “*compressibility effects*”. In general, *below* M_{crit} we can consider the flow to be “*incompressible*” and assume that *density is a constant*. Above M_{crit} we can’t do this and we must use a compressible form of equations like Bernoulli’s equation.

Based on the above, one name we often give to the Mach number is a “**similarity parameter**”. Similarity parameters are things we must check in making sure our experimental measurements and calculations properly account for things such as the drag rise that starts at M_{crit} . We don’t want to try to predict compressible flow effects using incompressible equations or test results or vice-versa.

The other three terms in our force relationship are also similarity parameters. Let’s look at the first term on the right hand side of that relationship. This grouping of terms is known as the **Reynolds Number**. Reynolds Number may be seen in different texts abbreviated in different ways [Re, Rn, R, Re_x , etc.] depending on the convention in the field of use and on its application. Here we will use **Re**.

$$Re = [\rho V L] / \mu$$

Reynolds number is really a ratio of the inertial forces and viscous forces in a fluid and is, in a very real way, a measure of the ability of a flow to follow a surface without separating.

Reynolds number is also an indicator of the behavior of a flow in a thin region next to a body in a flow where viscous forces are dominant, determining whether that flow is well behaved (**laminar**) or randomly messy (**turbulent**). This thin region is called the **boundary layer**.

Inertial forces are those forces that cause a body or a molecule in a flow to continue to move at constant speed and direction. Viscous forces are the result of collisions between molecules in a flow that force the flow, at least on a microscopic scale, to change direction. The combination of these forces, as reflected in the Reynolds Number, can lead a flow to be smooth and orderly and easily break away from a surface or to be random and turbulent and more likely to follow the curvature of a body. They also govern the magnitude of friction or viscous drag in between a body and a flow.

In general, a **laminar boundary layer**, which occurs at **lower Reynolds Numbers**, results in **low friction drag** (skin friction) but isn’t very good at resisting separation and may promote a **large “wake” drag**. A **turbulent boundary layer**, which occurs at **higher Reynolds Numbers**, has **higher friction drag** but resists flow separation better leading to **lower “wake” drag**. So which do we want? This all depends on the shape of the body and the relative magnitudes of wake and friction drag.

A classic case to examine is the flow around a circular cylinder or, in three dimensions, over a sphere.

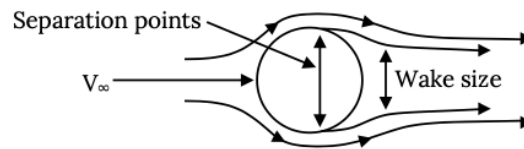
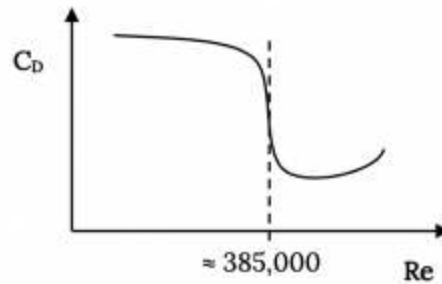

Figure 1.13: Flow Around a Circular Cylinder

Flow over a circular cylinder or sphere will generally follow its surface about half way around the body and then break away or separate, leaving a “wake” of “dead” air. This wake causes a lot of drag. This wake is similar to that seen when driving in the rain behind cars and especially large trucks. On a truck the point where the flow separates is about at the rear corners of the trailer body or tailgate. On a car it is often less well defined with separation occurring somewhere between the top of the rear window and the rear of the vehicle. On an aerodynamically well designed car the separation point would be right at the rear deck corner or at the “spoiler” if the car has one. A small wake gives lower drag than a large wake.

On a circular cylinder or sphere the separation point will largely depend on the Reynolds Number of the flow. At lower values of Re the flow next to the body surface in the “boundary layer tends to be “laminar”, a flow that is not very good at resisting breaking away from the surface or separating. Lower Re will usually result in separation somewhat before the flow has reached the half-way point (90 degrees) around the shape, giving a large wake and high “wake drag”. At higher Re the flow in the boundary layer tends to be turbulent and is able to resist separation, resulting in separation at some point beyond the half-way point and a smaller wake and wake drag.

Because the wake drag is the predominant form of drag on a shape like a sphere or circular cylinder, far greater in magnitude than the friction drag, the point of flow separation is the dominant factor in determining the value of the body’s drag coefficient.



Drag Coefficient Variation on a Sphere

Figure 1.14: Drag Coefficient Variation with Reynolds Number for a Sphere

In the above graph the Reynolds Number is based on the diameter of the sphere and the drag coefficient drops from a value of about 1.2 to about 0.3 as the “critical” Reynolds Number is passed at a value of about 385,000. This is a huge decrease in drag coefficient and illustrates how powerful an influence Re can have on a flow and the resulting forces on a body.

Note that a flow around a cylinder or sphere could fall in the high drag portion of the above curve because of several things since Re depends on density, speed, a representative length, and viscosity. Density and viscosity are properties of the atmosphere which, in the Troposphere, both decrease with altitude. The major things affecting Re and the flow behavior at any given altitude will be the flow speed and the body’s “characteristic length” or dimension. Low flow speed and/or a small dimension will result in a low Re and consequently in high drag coefficient. *A small wire (a circular cylinder) will have a much larger drag coefficient than a large cylinder at a given speed.*

Of course drag coefficient isn’t drag. Drag also depends on the body projected area, air density, and the square of the speed:

$$D = C_D (1/2\rho V^2 S)$$

Hence, it cannot be stated in general that a small sphere will have more drag than a large one because the drag will depend on speed squared and area as well as the value of the drag coefficient. On the other hand, many common spherically shaped objects will defy our intuition in their drag behavior because of this phenomenon. A bowling ball placed in a wind tunnel will exhibit a pronounced decrease in drag as the tunnel speed increases and a Reynolds Number around 385,000 is passed. A sphere the size of a golf ball or a baseball will be at a sub-critical Reynolds Number even at speeds well over 100 mph. This is the reason we cover golf balls with “dimples” and baseball pitchers like to scuff up baseballs before throwing them. Having a rough surface can make the boundary layer flow turbulent even at Reynolds numbers where the flow would normally be laminar.

The C_D behavior shown in the plot above is for a smooth sphere or circular cylinder. The same shape with a rough surface will experience “transition” from high drag coefficient behavior to lower C_D values at much lower Reynolds Numbers. A rough surface creates its own turbulence in the boundary layer which influences flow separation in much the same way as the “natural” turbulence that results from the forces in the flow that determine the value of Re . Early golfers, playing with smooth golf balls, probably found out that, once their ball had a few scuffs or cuts, it actually drove farther. They probably then started experimenting with groove patterns cut into the surface of the balls. This led to the dimple patterns we see today which effectively lower the drag of the golf ball (this is not all good since the same dimples make a golfer’s hook or slice worse). The stitches on a baseball have the same effect, and baseball pitchers have found in their own somewhat unscientific experiments that further scuffing the cover of a new ball can make it go faster just as spitting on it can make it do other strange things.

The sphere or cylinder, as mentioned earlier, is a classic shape where there are large Re effects on drag. Other shapes, particularly “streamlined” or low drag shapes like airfoils and wings, will not exhibit such dramatic drag dependencies on Re , but the effect is still there and needs to be considered.

Like Mach number, Re is considered a “similarity” parameter, meaning that if we want to know what is happening to things like lift and drag coefficient on a body we must know its Reynolds Number and know which side of any “critical Re ” we might be on. Flow over a wing could be quite different at sub-critical values of Re than at higher values, primarily in terms of the location of

flow separation, stall, and in the magnitude of the friction drag that depends on the extent of laminar and turbulent flow on the wing surface.

So in doing calculations and wind tunnel tests we need to look at the magnitude of Re and its consequences. In doing so, we can get into some real quandaries when we test scale models in a wind tunnel. If we, for example, test a one-tenth scale model of an airplane in a wind tunnel our “characteristic dimension” in the Reynolds Number will be 1/10 of full scale. So, if we want to match the test Re with that of the full scale plane, one of the other terms must be changed by a factor of ten. Changing velocity by an order of magnitude to ten times the full scale speed will obviously get us in trouble with the other similarity parameter, Mach number, so that won’t do any good. We must change something else or “cheat” by using artificial roughness to create a turbulent boundary layer when the value of Reynolds number is really too low for a turbulent boundary layer.

One of the biggest breakthroughs in aeronautics came in the 1920s when the National Advisory Committee for Aeronautics (the NACA) at Langley Field, VA built what they called a “Variable Density Wind Tunnel”. This was a test facility where the air density could be increased by a factor of 20, allowing the testing of 1/20 scale models at full scale Reynolds Numbers. The VDWT, now a National Historical Monument, was a subsonic wind tunnel built inside of a egg-shaped pressurized steel shell. Quite sophisticated for its time, the tunnel was pressurized to 20 atmospheres after the wing model was installed. The tunnel was operated and the test model was moved through a range of test angles of attack by operators who observed their tests through pressure tight windows that resembled ship portholes. The model wings, each with a five inch chord and a thirty inch span, were machined to very tight tolerances based on dimensions worked out by NACA scientists and engineers. For the first time the world of aeronautics had reliable, full scale aerodynamic measurements of wings with a wide range of airfoil shapes.

Today in wind tunnel testing we usually “cheat” on Reynolds Number by using “trip strips”, small sandpaper like lines placed near the leading edges of wings and fuselages to force the flow to transition from laminar to turbulent flow at locations calculated prior to the tests. Although the Variable Density Wind Tunnel was retired long ago, we still have a unique capability at what is now NASA-Langley Field with the National Transonic Facility, a wind tunnel in which the working gas is nitrogen at temperatures very near its point of liquification. Since density, viscosity, and speed of sound all change with temperature it is possible in the NTF to simulate full scale Reynolds Numbers and Mach numbers at the same time. While testing is not easy at these low temperatures, properly run investigations in the NTF can yield aerodynamic data that can be obtained in no other manner.

In concluding this discussion of Reynolds Number it should be noted that the “characteristic length” in Re may take several different values depending on convention and that the value of Re at which transition from laminar to turbulent flow occurs can also vary with application. As shown earlier, we base the Reynolds Number for a circular cylinder or sphere on its diameter. The transition Re is just under 400,000. However, if we were mechanical or civil engineers working with flows through pipes, we would use the pipe diameter as our dimension and we would find that transition takes place at Re of about 5000, some two orders of magnitude different from transition on the sphere. We need to be aware of this different perspective on the important magnitudes of Re when talking with our friends in other fields about flows.

When we are talking about the value of Reynolds Number on a wing or an airplane the characteristic dimension used is the mean or average chord of the wing, the average distance from the wing’s leading to trailing edge. When we are doing detailed calculations on the behavior of the flow in the boundary layer we will use yet another dimension, the distance from the stagnation point over the surface of the body to the point where we are doing the calculations.

OK, we have found our something about the importance of Mach Number and Reynolds Number, what about the other two groupings of parameters in the force dependency equation we had earlier?

There were two other terms, gl/V^2 , and $P/\rho V$. The first of these is a ratio of gravitational and inertial forces and relates to forces which arise as a consequence of a body being close to an “interface” such as the ground or the surface of the ocean. This term is usually inverted and its square root is known as the **Froude Number**.

$$\text{Froude Number} = V / [gl]^{1/2},$$

where the length in the equation is the distance between the body and the fluid interface; i.e., the height of the airplane above the runway or the depth of a submarine below the surface. Unless that distance is less than about twice the diameter of the submarine or the chord of the wing, Froude Number can be generally ignored; but within this range, it can help account for increases in drag or lift that may occur when a body is near a surface.

The final term, the **Euler Number**, $P/\rho V$, is really not important in air, but is used when looking for the likelihood of **cavitation** effects on a body in water. When the pressure in water is lowered to the vapor point of water at a given temperature, the water will boil even though temperature is lower than its usual boiling point. When flow accelerates around a ship propeller or hull the pressure can become low enough locally to boil the water, and this boiling or **cavitation** can cause serious increases in drag, noise, loss of propeller thrust, and damage to the surface itself. The term used to examine this is a modification of the one found in our analysis, rewritten slightly to account for the importance of the vapor pressure.

$$\text{Cavitation Number}(\sigma) = [P - P_v] / \rho V^2$$

Note that the denominator is a familiar grouping of parameters, twice the dynamic pressure.

1.14 Airfoils and Their Aerodynamic Coefficients

At the beginning of this text we looked at the terminology that is used to define the shape of the airfoil, things like chord, camber, and thickness, as well as the things like span, chord, sweep, and aspect ratio which define the shape of a complete wing. In the section above we found that the best way to talk about the forces acting on an airfoil (2-D) or a wing (3-D) is in terms of non-dimensional coefficients. Let's take a look again at those coefficients and how they are defined in both two and three dimensions and look at the way these change as a function of the wing or airfoil angle of attack to the flow.

A few pages back we defined the lift and drag coefficients for a wing. These are repeated below and are extended to define a *pitching moment coefficient*:

$$C_L = L / [1/2\rho V^2 S] = \text{Lift Coefficient}$$

$$C_D = D / [1/2\rho V^2 S] = \text{Drag Coefficient}$$

$$C_M = M / [1/2\rho V^2 S c] = \text{Moment Coefficient}$$

Note again that the area "**S**" is the "**planform**" area of the wing, the "*projected*" area one would see looking down on the wing and not its actual surface area. The moment coefficient has a slightly different denominator which includes the **mean or average chord** along with the planform area in order to make the coefficient unitless, since the pitching moment has units of force times distance. A little later we will look at the moment in more detail and see what reference point(s) should be used in measuring or calculating that moment.

The coefficients above are in three-dimensional form and are as we would define them for a full wing. If we are just looking at the airfoil section, a two-dimensional slice of the wing, the area in the denominator would simply become the chord.

$$C_L = L / [1/2\rho V^2 c] = \text{2-D Lift Coefficient}$$

$$C_D = D / [1/2\rho V^2 c] = \text{2-D Drag Coefficient}$$

$$C_M = M / [1/2\rho V^2 c^2] = \text{2-D Moment Coefficient}$$

It would be helpful to know something about the typical ranges of these coefficients in either two or three dimensions so we will have some idea how valid our calculations may be.

$$-2.0 < C_L < +2.0 \text{ for a normal wing or airfoil with no flaps}$$

$$-3.0 < C_L < +3.0 \text{ for a wing or airfoil with flaps}$$

$$0.005 < C_D < 0.025 \text{ for a wing or airfoil (more for a whole airplane)}$$

$$-0.1 < C_M < 0.0 \text{ for a wing or airfoil when measured at } c/4$$

It should also be noted that the pitching moment is defined as positive when it is "nose up". Depending on the direction of the airfoil or wing within an axis system this may be counter to mathematical custom. In fact, most texts commonly treat aerodynamics problems as if the freestream velocity is coming from the left in the positive x direction and the wing or airfoil is facing toward the left in a negative x direction. In such a depiction a positive pitching moment would be clockwise even though customary mathematical treatment would assign this a negative sign.

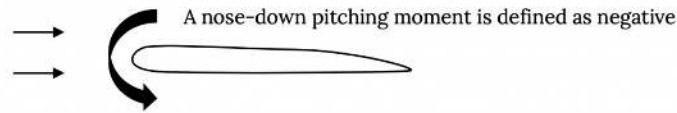

Figure 1.15: Definition of the Pitching Moment Sign

1.15 Angle of Attack

We also need to define the way we relate the orientation of the wing to the flow; i.e., the wing or airfoil **angle of attack**, α . At the same time we can look at the definition for the direction of lift and drag.

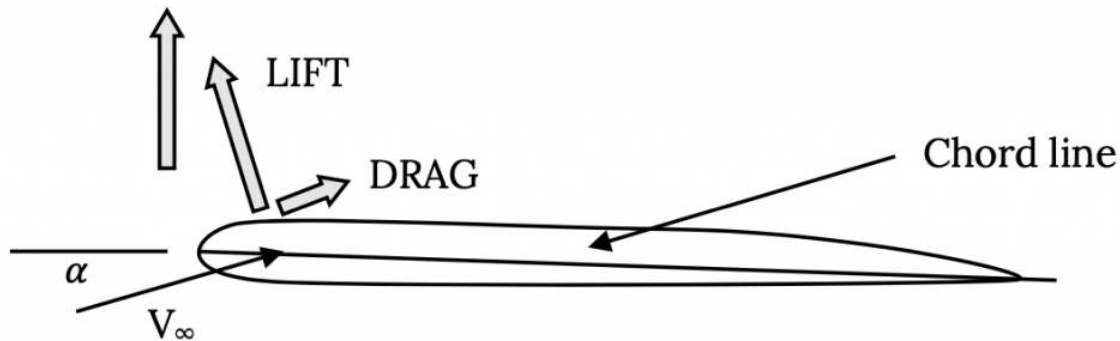

Figure 1.16: Relationship Between Lift, Drag, and Free Stream Velocity

Note that the **angle of attack**, α , is defined as the **angle between the wing or airfoil chord and the freestream velocity vector**, not between the velocity and the horizontal. Also note that **Lift and Drag are defined as perpendicular and parallel, respectively, to the freestream velocity vector**, not “up and back” or perpendicular and parallel to the chord. These definitions often require care because they are not always intuitive. In many situations the force we define as lift will have a “forward” component to it along the wing chord line. This is, in fact, the reason that helicopter and gyrocopter rotor blades can rotate without power in what is known as the “autorotation” mode, giving lift with an unpowered rotor.

Given these definitions lets look at the way lift and drag coefficient typically change with angle of attack.

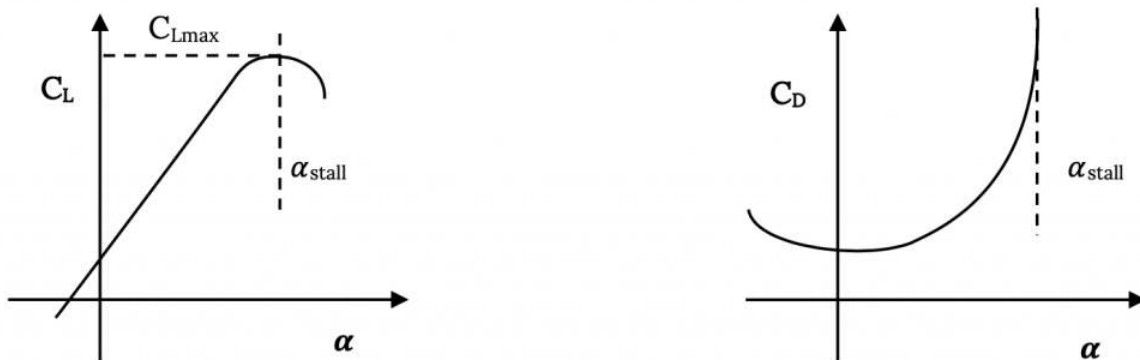

Figure 1.17: Plots of Lift and Drag Coefficient Versus α , Showing Stall

Let’s look at a few things in the above plots:

1. The lift coefficient varies linearly with angle of attack until the wing approaches stall. Stall begins when the flow begins to break away or separate from the wing’s upper surface and may progress quickly or gradually over the surface.
2. When the lift coefficient no longer increases with angle of attack, in the middle of stall progression, we have C_{Lmax} the largest value of lift coefficient we can get for a particular airfoil or wing at a given Reynolds number. The value of C_{Lmax} will, in general, increase with increasing Re.

3. The lift coefficient is not shown as zero in value at a zero angle of attack. On a “symmetrical” airfoil; i.e., one with no camber, the lift will be zero at zero angle of attack. On a cambered airfoil the lift will be zero at some negative angle of attack which we call the “**zero lift angle of attack**”, α_{L0} .
4. Drag increases rapidly in stall.

We should explore this idea of stall further because something seems amiss here. The plot above shows that **stall is where we have our maximum lift coefficient. How can that be true when we’ve always been told that stall is where an airplane loses lift?**

Our dilemma here stems from the meanings of two different terms, **lift and lift coefficient**. Let’s look at the relationship between lift and lift coefficient.

$$\text{Lift} = C_L [1/2 \rho V^2 S]$$

To have lift we must have two things, a good lift coefficient and the speed necessary to turn that lift coefficient into lift. So what is the problem here? The problem is drag.

When an airplane reaches C_{Lmax} it has its highest possible *lifting capability* or lift coefficient. But looking at the other plot, the one of drag coefficient, we see that it also has a rapidly increasing drag coefficient. The resulting drag causes a reduction in speed and, since speed is squared in the relationship above it has a much more powerful influence on lift than does the lift coefficient. Lift decreases as the speed drops and, indeed, even though we have a very high lift coefficient we can’t make enough lift to overcome the plane’s weight. And, as we can see from the plot on the left, if we go past the stall angle of attack we also get a decrease in lift coefficient.

As noted above up until stall the lift coefficient is shown to vary linearly with angle of attack and to become zero at the zero lift angle of attack α_{L0} . Given this we can write a simple equation for the value of C_L .

$$C_L = (dC_L/d\alpha) [\alpha - \alpha_{L0}]$$

Theory will show and experiment will verify that for an airfoil section (a two dimensional slice of a wing) this slope, $dC_L/d\alpha$, is **equal to 2π** , where the angles of attack are expressed in **radians**. So theoretically for an airfoil section this equation becomes:

$$C_L = 2\pi [\alpha - \alpha_{L0}]$$

For a three dimensional wing the slope of the curve may be less and both theory and experiment can be used to determine that 3-D slope.

So how does the shape of the airfoil section influence this relationship? First, the shape of the camber line will determine the value of the zero lift angle of attack. We will find in a later course in aerodynamics that there are ways to calculate α_{L0} from the shape of the airfoil camber line.

It is harder and may even be impossible to calculate the value of C_{Lmax} and the angle of attack for stall. These are functions of the thickness of the airfoil and the shape of its surface as well as of things like the Reynolds Number. We have to look at friction effects and Boundary Layer Theory to even begin to deal with the stall region successfully. Our only alternative is to use wind tunnel testing. And this is what the people at the National Advisory Committee for Aeronautics (NACA) which was mentioned earlier did in their Variable Density Wind Tunnel.

1.16 NACA Airfoils

In the 1920s the scientists and engineers at the NACA set out to for the first time systematically examine how things like camber line shape and thickness distributions influenced the behavior of airfoils. They began their quest by deciding how to define an airfoil shape using only three numbers and four digits. They looked at the best airfoil shapes of their time and found a good way to vary the thickness of the airfoil from its leading edge to the trailing edge and wrote an equation for this distribution that allowed everything to be defined in terms of one, two-digit number. Then they wrote two equations for the airfoil camber line, one for the front part of the wing up to the point of maximum camber and the other for the aft part of the wing behind the maximum camber location. These two equations depended on two single-digit numbers, one giving the location of the maximum camber point in tenths of the chord and the other giving the maximum distance between the camber and chord lines in hundredths of the chord. Then they used these four digits to identify the resulting airfoil.

For example, the **NACA 2412** airfoil is an airfoil where each of the numbers means something about the shape:

2 – The maximum distance between the chord and camber lines is 2% of the chord.

4 – The location of the point of maximum camber is at 40% chord.

12 – The maximum thickness of the airfoil is 12% of the chord.

These four digits (three numbers) could then be used with related equations to draw the airfoil shape.

Using this method the NACA could systematically look at the effects of just the amount of maximum camber by testing a series of shapes such as 1412, 2412, 3412, etc. , or they could hold the maximum camber steady and look at the effect of placement of maximum camber (2212, 2312, 2412, 2512, etc.) , or fix the shape of the camber line and look at the effect of thickness variation (0006, 0009, 0012, 0015, 0021, etc.). *Note that this last set of airfoils are all symmetrical; i.e., zero camber.* And this is precisely what was done with tests on hundreds of airfoils. A wide variety of airfoils were tested in the Variable Density Wind Tunnel and the results plotted. Sample plots are presented in [Appendix A](#).

The first set, Figures A-1 (A&B), is for an **NACA 0012** airfoil section. Note that this is a symmetrical airfoil section (the first zero indicates that there is **no camber** and thus the second number is meaningless) and has a 12% thickness. We first see that there are several plots on each of the two graphs and that there are multiple definitions of the vertical axis for each plot. On the left hand plot the horizontal axis is the angle of attack given in degrees and the primary vertical axis is the section or two-dimensional lift coefficient. There is also a secondary vertical axis for the pitching moment coefficient (with the moment measured relative to $c/4$, the quarter chord).

There is a lot of information given on plot A. The first thing we note is that there are two sets of lift coefficient curves and that each of these seems to have a couple of different plots of the stall region. Note that the linear portion of one set of these curves goes through the plot axis showing that the lift coefficient is zero at an angle of attack of zero. These curves are for the basic 0012 airfoil which is a symmetrical airfoil and will have no lift at zero angle of attack.

There are, as noted above, at least two different stall region plots for this symmetrical airfoil. To understand these we need to look at the inset information about Reynolds number (noted as simply “R” on these plots). There are four different symbols shown in this inset. The “diamond” symbol denoted data for the wing tested at a Reynolds number of 9×10^6 , the square for $Re = 6 \times 10^6$, and the circle for $Re = 3 \times 10^6$. The other symbol, a triangle, is for the airfoil tested with a “standard roughness” or a roughened surface at a $Re = 6 \times 10^6$. Usually the higher the value of Reynolds number the higher the value of maximum lift coefficient but in this particular case there is only a slight increase with C_{Lmax} moving up from about 1.5 to 1.6 as Reynolds number on the smooth airfoil increases from 3 to 6×10^6 . For the smooth surface stall always occurs at 16 degrees angle of attack. Note also that the airfoil also stalls at minus 16 degrees angle of attack, verifying its symmetrical behavior. The rough surface causes a much earlier stall and lower value of C_{Lmax} .

So, what is the other set of “lift curves” that are displaced up and to the left on this plot? These are the data for the 0012 airfoil with a trailing edge flap. Other inset information on the plot tells us that this is a split flap with a chord of 20% of the airfoil chord and it is deflected 60 degrees. Note that the basic airfoil is drawn to scale on the right hand plot and the flap and its deflection are noted in dashed lines on the drawing.

This data shows that for this particular flap the lift curve shifts to the left such that it has zero lift at minus 12 degrees, in other words α_{LO} , the zero lift angle of attack, is minus 12 degrees for the flapped airfoil. The curves show that the deflection of the flap has increased C_{Lmax} from about 1.6 up to about 2.4, a 50% increase. C_{Lmax} for the rough surface airfoil has gone from 1.0 to 1.9.

Now, there are two other curves on this plot. They are curves for the pitching moment coefficient about the quarter chord, with and without flap deflection. First note that the scale to the left of the plot is different for moment coefficient than it was for lift coefficient. Do not confuse these two scales. Next, note that the upper of these two curves is for the wing without flaps and that it has a value of zero over the range of angle of attack where the lift curve is linear. This means that the pitching moment is zero at the quarter chord for this airfoil. This is true for all symmetrical airfoils. We define the place where the **pitching moment is zero** as the **center of pressure (sometimes called the center of lift)** and we define the place where the **pitching moment coefficient is constant with changing angle of attack as the aerodynamic center**. We will look at these further a little later. **For a symmetrical airfoil the center of pressure and the aerodynamic center are both at $c/4$.**

Now let’s look at the plot B for the 0012 airfoil. This plot displays test results for drag coefficient and moment coefficient and plots them versus the lift coefficient, not the angle of attack. So to find the drag coefficient at a certain angle of attack requires us to first

find the value of C_L at that angle of attack and then use it to find C_D .

Again on this plot there are different sets of data for different values of Reynolds number and roughness. Note that C_D is smallest at zero angle of attack for this symmetrical airfoil as would be expected, and that as angle of attack is increased C_D increases. The moment curve on this plot is for the moment coefficient at the aerodynamic center and not for $c/4$ as in the plot on the left. However, as noted above, for a symmetrical airfoil the aerodynamic center is at the quarter chord so these are the same here.

The next plot in Appendix A, Figure A-2 (A&B), shows similar data for the **NACA 2412** airfoil. Like the 0012 airfoil this shape has 12% thickness but now it has a slight (one percent) camber with the maximum camber located at 40% of the chord. So we can compare these plots with the first ones to see the effect of added camber. Looking at all the same things mentioned above we see that the airfoil now has a positive lift coefficient (0.15) at zero angle of attack and that the zero lift angle of attack is now minus-one degree. C_{Lmax} is still about 1.6 for the unflapped wing but with flap deflection it has increased slightly from the symmetrical case. Pitching moment coefficient is no longer zero at $c/4$ but it is still constant, now at a value of about -0.025 ; i.e., a slightly nose down pitching moment. Since the pitching moment at $c/4$ is still constant this point is still the aerodynamic center but it is no longer the center of pressure. The minimum drag coefficient is about the same as for the symmetrical wing and it is still minimum at about zero angle of attack but this is no longer at zero lift coefficient.

We can see the result of further increases in camber to two percent in the plots for the **NACA 2412** airfoil. There is no data for flap deflection included in these plots. In this plot we can see that the pitching moment continues to increase negatively (nose down) as camber is increased and that the minimum drag coefficient has also begun to increase. The zero lift angle of attack and the lift at zero angle of attack are both seen to continue to increase in magnitude as camber is added as theory would suggest.

The next plots, Figure A-3 (A&B), for the **NACA 2415** show very slight changes in the airfoil behavior with increased thickness from 12% to 15% but for the **NACA 2421** section we see that the added thickness is resulting in earlier stall, decreased C_{Lmax} , increased drag coefficient, and in a non-linear moment coefficient variation with angle of attack about the quarter chord. This might suggest to us that 21% thickness is a little too thick.

The data (Figure A-4 (A&B)), for the **NACA 4412** airfoil continues to illustrate the trends discussed above, looking at the effect of adding more camber.

The last two plot sets, Figures A-5 and A-6, are for a different design of airfoil, the **NACA 6-series airfoil**, a shape we will discuss first before looking further at the graphs.

The NACA tested a wide variety of airfoil shapes in its four digit series investigations. However there were some limits to the shape variations one could get using the four digit designation. They couldn't, for example, look at an airfoil with maximum camber at 25% of the chord, only 20% or 30%. Hence they went on to develop a 5 digit airfoil series. Later they looked at an airfoil series designed to optimize the use of laminar and turbulent flow in the boundary layer to minimize drag and developed the 6-series airfoils. Let's look at both of these.

The **NACA 5-digit series** used the same thickness distribution as the four digit series but allowed more flexibility in defining the position of maximum camber. It also attempted to relate the amount of camber and the first digit in the airfoil designation to a "design C_L ". The design C_L is the lift coefficient viewed as optimum for the performance objectives of a given airplane. A long range transport may have a design lift coefficient of around 0.3 while a fighter aircraft might have a higher design C_L . An example of an NACA 5-digit airfoil is given below with an explanation of the numbering system:

NACA 23021

2 – the maximum camber is approximately 0.02 and the design C_L is $2 \times 0.15 = 3.0$

30 – the position of the maximum camber is $(0.30/2)$ times the chord or 0.15c

21 – the maximum thickness is 0.21c

The **NACA 6-series** (note that this is simply called the "six" series and not the six digit series although most of the designation numbers do have six digits) was developed in the 1930s in an attempt to design a series of airfoil shapes which optimized the areas of laminar and turbulent flow in the boundary layer on the wing. As we discussed earlier, laminar flow in the boundary layer is a low friction flow and that is good; however, laminar flow is poor at resisting flow separation and separation results in high drag and low lift. A turbulent boundary layer is much better at resisting flow separation than a laminar one but it has higher friction drag.

Flow separation is much more likely when the flow is decelerating (where the pressure is increasing, known as an “adverse” pressure gradient because separation is likely). The flow over an airfoil will usually be accelerating over the front of the shape up to the point of its minimum pressure which is usually at about the point of maximum thickness. Here it is safe to have laminar flow because the flow is not likely to try to separate. If we want more laminar flow and, hence, a larger part of the airfoil with low friction drag, we can move the maximum thickness point more toward the rear of the airfoil. The idea is to get as large as possible an area of laminar flow and then let the boundary layer transition to turbulent flow before the thickness starts to decrease so the turbulent boundary layer will resist separation. This results in an airfoil with a smaller leading edge radius than the older designs and with the maximum thickness further back.

Two such 6-series shapes are sketched as part of their NACA data plots in Appendix A, the *NACA 65₁-212* and *65₁-412* airfoils. One thing that is immediately obvious when comparing these two data plots to those of the NACA 4-digit airfoil data is the “bucket” in the center of the drag coefficient curves in the right hand plots. This so-called “**drag bucket**” is characteristic of the 6-series airfoils. All of these airfoils have a region of angle of attack or lift coefficient over which the drag is considerably lower than at other angles of attack. This is the range of angle of attack where laminar flow can exist over a large part the forward portion of the airfoil, giving a reduction in friction drag.

The 6-series airfoil numbering system is devised to help the designer/aerodynamicist select the best airfoil for the job by telling where the center of the “drag bucket” is located and telling the extent (width) of that drag bucket. In other words, if a designer wants a wing with an airfoil section that gives a design lift coefficient of 0.2 he or she wants the center of the drag bucket to be at a C_L of 0.2 so the airplane will be able to do its design mission at the lowest possible drag conditions. Hence, one of the numbers in the 6-series designation tells the C_L for the center of the drag bucket. Lets look at one of these airfoil designations and see what the numbers mean.

NACA 65₁-212

6 – this is merely the “series” designation

5 – the minimum pressure location at zero lift is at 50% chord

1 – this is a subscript which may or may not appear in a 6 series designation. It means that the width of the “drag bucket” extends for a range of C_L of 0.1 above and below the design C_L

2 – the design C_L is 0.2

12 – as always, the maximum thickness as a % chord

Now if we again look at the data for the above airfoil we see that the drag bucket is indeed centered at a lift coefficient of about 0.2 and the bucket extends for at least a C_L range of 0.1 on both sides of its center. Similarly if we look at the plots for the NACA 65₁-412 we find that the drag bucket is further to the right and centered at about a C_L of 0.4.

A closer comparison of these 6-series aerodynamic data with those of the 4-digit series cases will show that not everything is better. The 6-series airfoils often stall a little earlier due to their smaller leading edge radii and hence have slightly lower $C_{L,max}$ values than their earlier counterparts. Also their drag coefficients outside of the range of the drag bucket may be higher than conventional airfoils. As in all things in real life improvements in one area are often accompanied by penalties in others. Nonetheless, the 6-series airfoils are excellent designs and are still used today on many aircraft.

1.17 Pitching Moment

Before we look further at airfoil development we should step back a bit and look further at two things mentioned earlier, the **aerodynamic center** and the **center of pressure**. These are two important points on the airfoil that depend on the behavior of the pitching moment. A moment must be referenced to a point and these happen to be very meaningful points about which to reference the pitching moment on an airfoil or wing.

The moment on an airfoil is related primarily to the way lift is produced on the shape. Drag also contributes to the moment but to a much smaller extent. At subsonic speeds the lift on most airfoils is higher on the front part of the shape than at the rear and might look something like this:

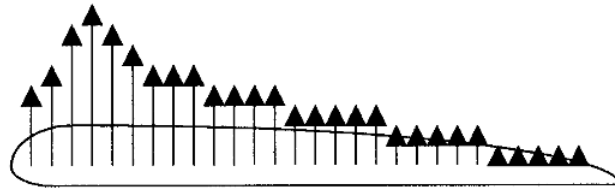

Figure 1.18: Type of Pressure Distribution

If we choose to talk about the pitching moment about the airfoil leading edge, the moment would always be nose down or counterclockwise. If we sum up the moments at some point about half way back along the chord the moment would be nose up or clockwise since the lift forces to the left are greater than those on the right. Obviously there is some point between the airfoil leading edge and its center where **the moments would sum to zero**. This would be the **center of pressure**. It might be interesting and useful to know where this place is since it seems to be a natural balance point or sorts. The only problem is that this position may move as the airfoil changes angle of attack. For example, at higher angle of attack even more of the lift might be produced near the front of the airfoil and the center of pressure would move closer to the nose of the airfoil.

As it turns out, according to aerodynamic theory which you will examine in a later course, there is another point which is of even more interest, the **aerodynamic center**. **This is the point where the moment coefficient (not the moment itself) is constant over a wide range of angle of attack**. Basic aerodynamic theory will tell us that this is approximately at the **quarter-chord** of the airfoil in **subsonic flow**. This was seen to be the case for the airfoils whose data are shown in Appendix A.

Theory will also show and experiment will verify that for a symmetrical airfoil such as the NACA 0012 shape in Appendix A the aerodynamic center and the center of pressure are in the same place. In other words, for symmetrical airfoils at the aerodynamic center the pitching moment is not only constant but is also zero. This makes the aerodynamic center a very convenient place to locate major structural elements or to use as the balance point for control surfaces.

1.18 Camber and Flaps, and Flight at Reduced Speeds

We have seen in the data of Appendix A that as the camber of a wing increases its aerodynamic performance changes. Looking at the data for the NACA 0012, 1412, and 2412 airfoils we saw that as camber (indicated by the first term in the NACA four digit numbering system) is increased the lift curve shifts to the left giving more lift coefficient at zero angle of attack, an increasingly negative angle of attack for zero lift coefficient, and a slowly increasing value of maximum lift coefficient. This is accompanied by a slight increase in drag coefficient and a negative increase in pitching moment coefficient at the aerodynamic center as camber increases. In later aerodynamics courses you will learn how to predict these changes which result from modification of the airfoil camber line shape. It is evident now, however, that increasing camber can give higher lift coefficients and both the airplane designer and the pilot may wish to take advantage of this. One type of flight where this becomes very useful is low speed flight, especially in takeoff and landing.

To fly the lift of the airplane must equal its weight.

$$W = L = C_L(1/2)\rho V^2 S$$

This relationship says that lift comes from four things, the lift coefficient, the density, the velocity, and the wing planform area. There is nothing much we can do about the density, it comes with the altitude, and while there are ways to change the wing area while a plane is in flight, these are often impractical. We note that speed is a powerful factor since it is squared.

The equation above essentially tells us that if we want to fly at a lower speed with a given wing and altitude we must increase the lift coefficient. We can do this to a certain extent as we increase the angle of attack from the zero lift angle of attack to the angle for stall, but stall defines our limit.

$$W = L = C_{L_{max}}(1/2)\rho V_{stall}^2 S$$

We, of course, don't want to try to fly at $C_{L_{max}}$ because we will stall, but the stall speed does define the minimum limit for our possible range of flight speed at a given altitude. If we want to fly at lower speed we need to increase the value of $C_{L_{max}}$. The graphs in Appendix A show us that this can be done with flaps. On the plot for the NACA 1412 airfoil we see that by deflecting a

split flap with a length of 20% of the airfoil chord to an angle of 60 degrees we can increase the maximum lift coefficient from 1.6 to 2.5, a change which would lower our stall speed by 20 percent. This means that we can fly at a 20% lower speed.

This is a powerful effect but it isn't free. It is accompanied by a large increase in drag coefficient and a huge change in pitching moment. This may mean a need for a larger horizontal stabilizer or canard to counter the pitch change and we will need to deal with the drag.

In the early days of flight there was no real need for flaps. Aircraft flew at speeds very slow by today's standards and their stall speeds were often very low due to large wing areas. But as research showed how to reduce airplane drag and better engines gave increasingly more power and thrust not as much wing area was needed to cruise at the resulting higher speeds. Airplane designers found that making a plane cruise at over 200 mph and still land at something like 60 mph or less was a problem. Landing speed is important because it is directly related to stopping distance and the needed runway length. Higher landing speeds also may increase the risk of landing accidents.

Most airplanes cruise at a lift coefficient of about 0.2 to 0.3 and the best subsonic airfoils will have a C_{Lmax} no higher than 1.8. These two factors define the problem of high speed cruise and low speed landing.

In 1933 the Boeing Company brought out the Boeing 247 airliner, a thoroughly modern plane for its time which took advantages of all the accumulated progress in engine and airframe design. Its cruise speed was 188 mph at an altitude of 8000 feet. The 247 weighed 13,650 pounds and had a wing area of 836 ft². A quick calculation of its cruise lift coefficient gives $C_L = 0.23$, a reasonable value. At that time existing runways required a landing speed of around 60 mph and a calculation of the 247's lift coefficient at sea level at 60 mph gives 1.77, pretty near the maximum for a conventional wing.

The Douglas Aircraft Company (now a part of Boeing) decided to build a bigger and more comfortable airliner and came out with the DC-1, the prototype airplane, and the production model DC-2. The DC-2 weighed 36% more than the 247 at 18,560 pounds and had a slightly higher wing area of 939 ft², but it cruised at about the same speed and altitude as its competitor. The cruise C_L for the DC-2 comes out to be about 0.27, higher than the 247 because of its significantly larger weight. This higher "wing loading" gave the DC-2 passengers a more comfortable ride than the 247.

To land the DC-2 at 60 mph requires a C_L of about 2.15, too high for a normal wing. The solution was to add flaps, giving extra camber and a higher C_{Lmax} when needed for landing and takeoff. This allowed the larger, more comfortable DC-2 to fly as fast as the 247 and still land and takeoff at all the commercial airports of its day. The DC-2 and its even larger and more comfortable sibling, the DC-3, went on to revolutionize the airline industry.

It should be noted that large flap deflections are used in landing where the added drag may actually be advantageous and smaller deflections are used in takeoff where lower drag and rapid acceleration are a must.



Figure 1.19: The Boeing 247



Figure 1.20: The Douglas DC-2

There are many types of flaps. There are both leading edge and trailing edge flaps and an array of variations on both. Aerodynamic theory tells us that a camber increase is most effective when it is made near the trailing edge of an airfoil, hence, the trailing edge flap is the primary type of flap used on wings. The deflection of virtually any type of trailing edge flap from a simple flat plate to a complex, multi-element flap system will shift the “lift curve” to the left and increase $C_{L_{max}}$. Some trailing edge flaps have slots and multiple elements to help control the flow over the flaps and prevent separation to give even higher lift coefficient and often these flaps deploy in such a way as to temporarily add extra wing area.

Leading edge flaps do little to move the lift curve to the left but can do a lot to allow the airfoil to go to a higher angle of attack before stalling, by controlling the flow over the “nose” of the airfoil and delaying separation. Leading edge flaps are often used in takeoff and landing in conjunction with trailing edge flaps. A few aircraft have been designed with leading edge flaps or slots fixed permanently into the wing to give them lower stall speeds.

The effects of both leading and trailing edge flaps are shown in the following figure.

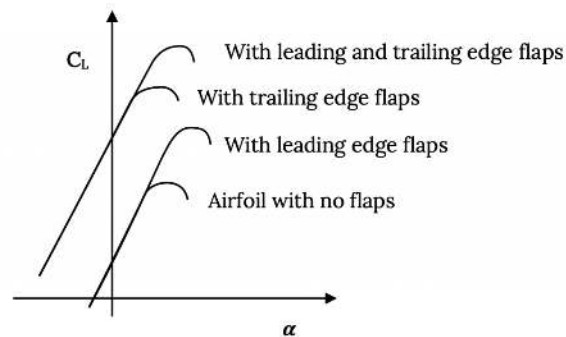

Figure 1.21: Typical Leading and Trailing Edge Flap Effects

The following table lists typical magnitudes of lift coefficient with and with out both leading and trailing edge flaps for a “Clark Y” airfoil. The Clark Y airfoil is a famous non-NACA airfoil shape developed by Virginius Clark. Clark had served on the same commission as many of the founders of the NACA, a commission charged with studying European airfoil sections after World War I and, using much of the same information that the NACA used to develop its original 4 digit airfoils, Clark developed the Clark Y and other airfoils as part of his Ph.D research at MIT. In the Clark Y, Virginius Clark designed an airfoil shape with a flat bottom that made it easy to manufacture, and because of this and its excellent aerodynamic performance, it was used widely for everything from airplane wings to propeller blades.

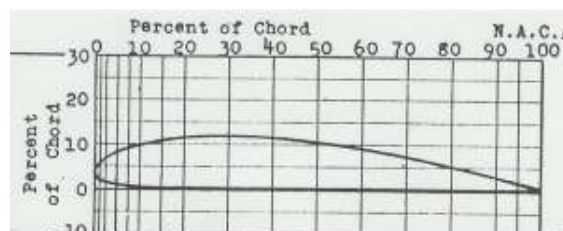

Figure 1.22: The Clark Y Airfoil Shape

Table 1.3: Leading edge and trailing edge flap and slot effects on a Clark Y airfoil

Configuration	$C_{L_{max}}$	$\alpha_{sub\ stall}$
Basic Clark Y airfoil	1.29	15
with 30% plain flap at 45°	1.95	12
with "fixed" slot and no flap	1.77	24
with slot and plain flap	2.18	19
with 40% Fowler flap at 40°	3.09	14
with deployable slot and Fowler flap	3.36	16

To summarize, a trailing edge flap can have a significant “camber effect”; i.e., can shift the “lift curve” to the left, increasing the zero lift angle of attack and the value of $C_{L_{max}}$. It can also be deployed in such a way as to temporarily increase wing area. A leading edge flap or slot will probably not produce a “camber effect” (if it does it is likely to be a “negative” one, slightly shifting the “lift curve” to the right) but will help retard stall to a higher angle of attack whether used on a wing with or without flaps.

1.19 Transonic and Supersonic Airfoils and Wings

Earlier we looked at the way flow can accelerate to supersonic speeds over an airfoil or wing as the free stream speed approaches the speed of sound and how, at Mach numbers higher than some “critical Mach number” the deceleration of that supersonic flow back to subsonic speeds can result in sudden flow separation and a drag increase. There are two ways to reduce this drag. One is by sweeping the wing and the other is by designing a special airfoil section.

1.20 Wing Sweep

The first way found to successfully decrease the drag rise that occurs in the transonic flight regime is by sweeping the wing. Theory and experiment showed that both the onset and the magnitude of the drag increase were functions of the “normal component” of the free stream Mach number, M_∞ . In other words, if a wing is swept 45° the normal component of the free stream Mach number is $M_\infty \cos \theta$ or 0.707

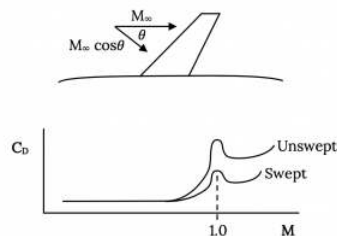

Figure 1.23: General effects of wing sweep on transonic drag rise

As with almost everything this benefit of sweep comes at a cost. Sweeping the wing also reduces its lift coefficient at a given angle of attack (reduces the slope of the lift curve) and the curved flow over the wing itself can lead to premature stall near the wing tips and a phenomenon known as “pitch up”

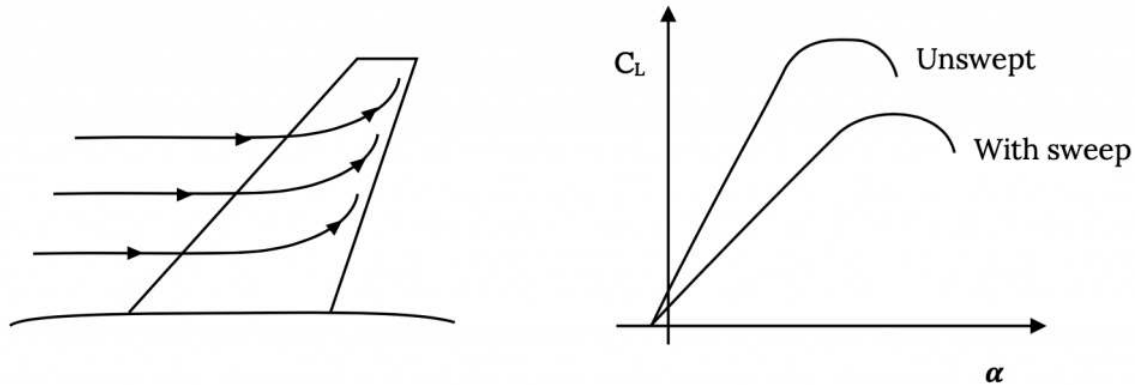

Figure 1.24: Other Effects of Wing Sweep

While most swept wings are angled toward the rear of the plane or swept back, theoretically it doesn't matter whether the wing is swept forward or aft. Several early swept wing designs were drawn with forward swept wings which allowed the wing spar or structure to pass through the fuselage aft of the cockpit and presented fewer internal design problems but it was soon discovered that there was indeed a problem with forward swept wings. This problem was caused by the same type of curving flow that caused tip stall on the aft swept wings except that the result on the forward swept wing was an added lift at the wing tips that tended to twist the wings to their breaking point at fairly low speeds. There was little point in sweeping a wing to lower the transonic drag rise when the wing would break off long before such speeds were reached and the added weight needed to stiffen the wing to prevent failure made the airplanes too heavy. This problem was finally solved in the 1970s with the use of fabric based composite structures which could be designed in such a way that the wing got stronger as it tried to twist off. The X-29 experimental aircraft successfully proved that swept forward wings could indeed be used in transonic flows.

1.21 Supercritical Airfoils

The other method used to reduce the transonic drag rise on a wing was developed by Richard Whitcomb at NASA-Langley Research Center in the 1960's. Dr. Whitcomb essentially reshaped the conventional airfoil section to do three things. He increased the "roundness" of the airfoil leading edge to give a more gradual acceleration of the flow to a speed lower than conventional airfoil shapes so when supersonic flow resulted on the surface it was weaker. He reduced the wing camber at its mid chord area to flatten the upper surface and allow a longer region of this weaker supersonic flow before allowing it to decelerate, giving less separation and drag. Finally, to make up for the lift that was lost by designing for slower upper surface flow, Whitcomb designed his airfoil with significant "aft camber" on its lower surface, noting that camber has a very powerful effect near an airfoil trailing edge. The result was an airfoil somewhat like the one below which gave excellent aerodynamic performance with a reduced transonic drag rise. This type of airfoil is called a Whitcomb airfoil or a "supercritical" airfoil.



Figure 1.25: Supercritical Airfoil Shape

As it turned out, this airfoil was an excellent design for all ranges of flight with its only drawback being a tendency toward a large pitching moment due to the aft lower camber. Subsequent designs have reduced this problem and variants of this design are used on almost every type of aircraft today.

While discussing Richard Whitcomb and transonic flow, his "coke bottle" fuselage design should also be mentioned. In the early 1950's as jet fighters were approaching Mach 1 in capability, the transonic drag rise of the whole airplane continued to be a problem in "breaking the so-called sound barrier". Convair and the Air Force hoped that a new, highly swept, delta wing fighter designated the F-102 would be able to routinely fly at supersonic speeds; however two prototype aircraft failed to reach Mach 1. Whitcomb realized that, at the speed of sound, the air cannot be compressed any further and needs some place to go or it will simply push outward from the plane, displacing other airflow and causing drag. He suggested a redesign of the F-102 fuselage with

a reduced cross section in the vicinity of the wing to allow this supersonic air a place to go without pushing away outer flows. The “wasp-waist” or “coke-bottle” fuselage was the result and the design which could formerly not make it to the speed of sound reached Mach 1.22 on its first flight.

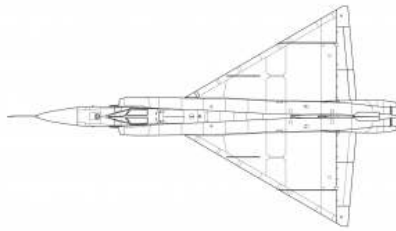

Figure 1.26a: Convair F-102 “Delta Dagger”



Figure 1.26b: Convair F-102 “Delta Dagger”

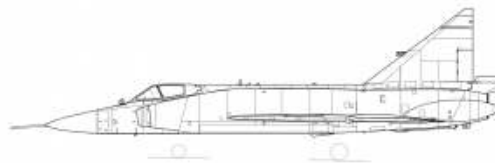

Figure 1.26c: Convair F-102 “Delta Dagger”

1.22 Three Dimensional Aerodynamics

Most of the things discussed in the previous sections were two dimensional phenomenon such as airfoil section design, the effects of camber, etc. Wing sweep was the exception. But there are many other variations in wing planform and shape that will influence the aerodynamic performance of a wing. Let’s start by looking at the **Aspect Ratio**.

A wing which is producing lift must have a lower pressure on its upper surface than on the lower surface. At the wing tips there is nothing to prevent the air from the lower surface from trying to go around the wing tip to the upper surface where the lower pressure acts like a vacuum. The result is some loss of lift near the wing tip. An ideal wing would have the same lift from wing tip to wing tip but a real wing doesn’t.

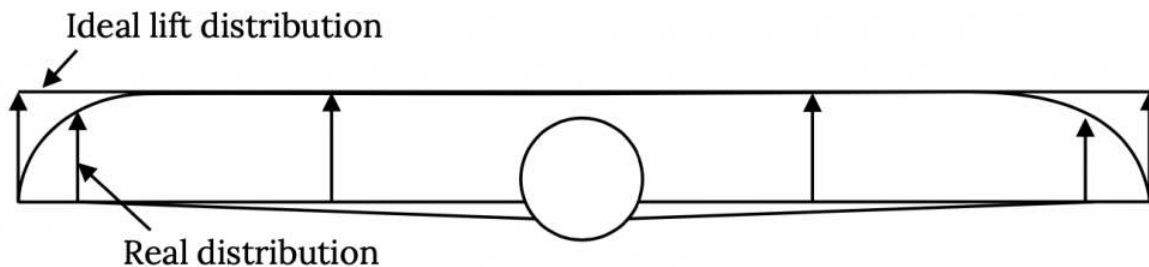

Figure 1.27: Ideal (2-D) and Real (3-D) Lift Distributions on a Wing

This loss of lift is felt for some distance inboard of the wing tips. The question is what percentage of the wing area this affects and this will depend on the wing **Aspect Ratio, AR**.

Aspect Ratio is a measure of the wing's span divided by its "mean" or average chord. It can also be expressed in terms of the square of the span and the planform area.

$$AR = b^2/S = b/c_{avg}$$

where **b = wing span**, **S = planform area**, **c = chord**

To see why aspect ratio is important we can look at two different wing planforms of the same area but different aspect ratios.

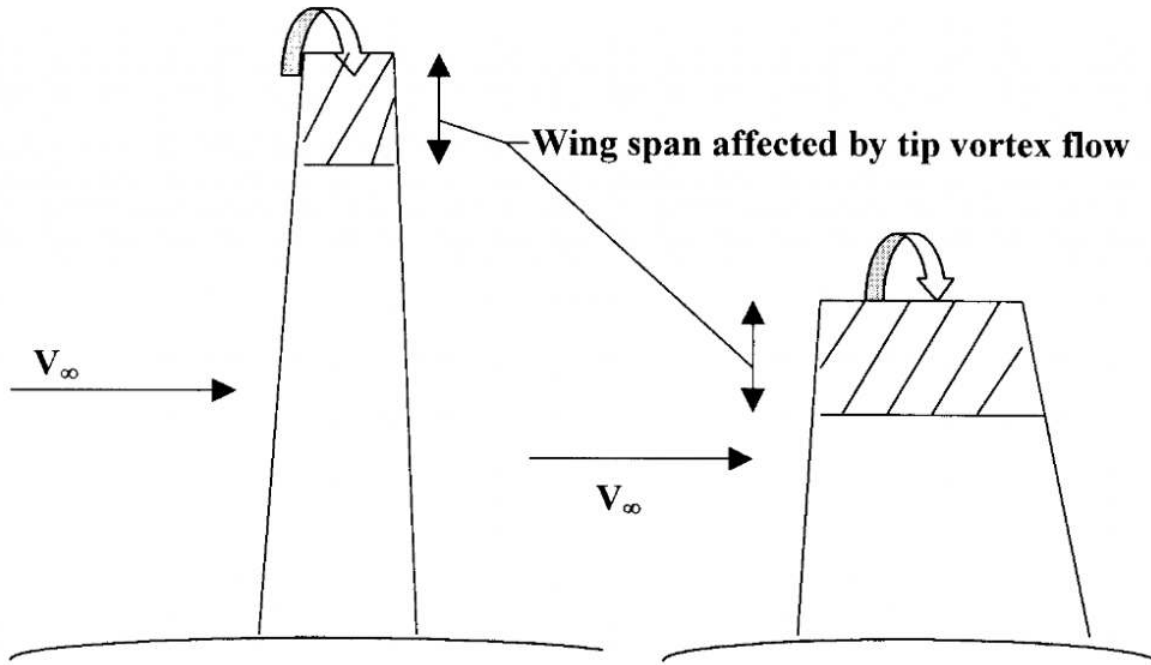

Figure 1.28: High AR wing on left has less area affected by flow around tip and, thus, less lift loss than the lower AR wing on the right.

This flow around the wing tip results in two other problems, the production of a drag called the **induced drag** and the creation of a tornado-like swirling flow, called a **wing-tip vortex** behind the wing tip that can be a hazard to following aircraft.

The trailing vortices (one vortex from each wing tip) can continue for miles behind an aircraft and the "strength" of the vortices will depend on the weight of the generating aircraft. A following airplane, particularly a small one, may find itself suddenly turned upside down (or worse) if it encounters one of these vortices. This is particularly dangerous near the ground and is one of the reasons for required separation times between landing and taking off airplanes at airports.

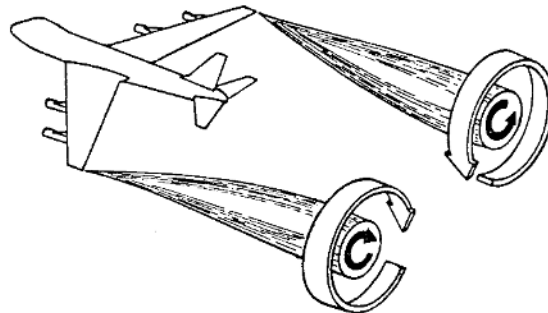

Figure 1.29: Trailing Vortices

The 3-D problem of concern here is the added drag which comes from this flow around the wing tips and the decreased lift. Because of this flow the lift coefficient on a 3-D wing will be lower at a given angle of attack than a 2-D airfoil section of the same shape. Aerodynamic theory can be used to calculate the 3-D effect as a function of the planform shape of the wing and that effect

can be characterized as an aspect ratio effect. A 2-D airfoil section is said to have an infinite aspect ratio and for the 2-D case theory gives a slope for the “lift curve” ($dC_L/d\alpha$) of 2π . For the 3-D case where aspect ratio is finite the slope of the lift curve will be found to decrease with decreasing aspect ratio.

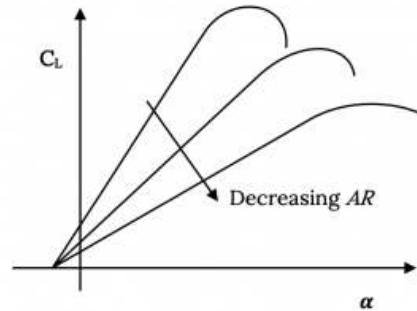

Figure 1.30: The “slope” of the lift curve decreases as AR decreases

The added drag in 3-D comes from the same phenomenon that causes lift. We define lift as a force perpendicular to the free stream velocity. **Induced drag** is a force that is perpendicular to the “downwash” velocity caused by the flow around the wingtip. This downwash velocity is small compared to the freestream flow and the induced drag is correspondingly small but it is still a force we need to understand and deal with.

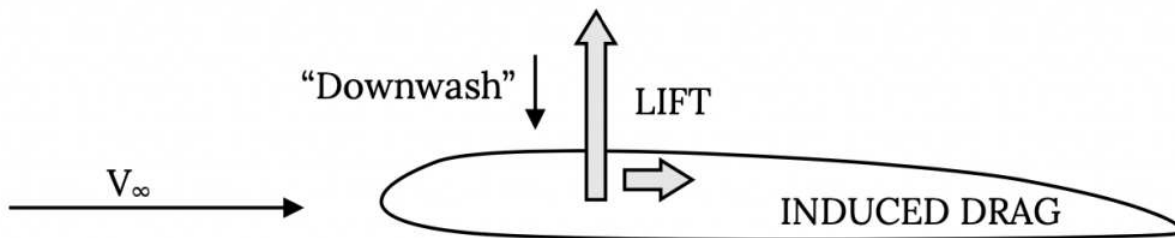

Figure 1.31: Downwash and Induced Drag

Theory will show the **induced drag coefficient** C_{Di} to be:

$$C_{Di} = C_L^2 / \pi AR e$$

From this it can be seen that as AR increases the induced drag decreases and that in the 2-D case where the theoretical aspect ratio is infinity, the induced drag coefficient is zero. But, what about the other term in the equation, e ?

e is called the “**Oswald efficiency factor**”. The value of e will be somewhere between zero and one with one being the best or “**minimum induced drag**” case. Theory will show that e is a function of the way lift acts along the span of the wing which is a function of several things, including wing planform shape, wing sweep, wing twist, taper, the various airfoil sections used across the span, etc. A study of this theory will show that the best case, when $e = 1.0$ occurs when the lift is distributed along the wing span in an **elliptical** manner. *This minimum induced drag case is often called the elliptical lift distribution case.*

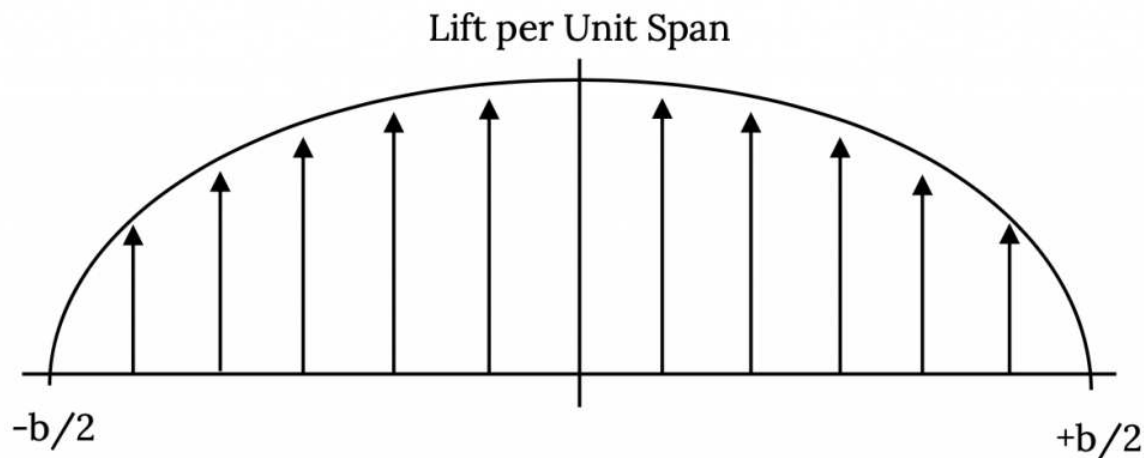

Figure 1.32: An Elliptical Lift Distribution

There are many ways to get an elliptical lift distribution. The easiest to visualize is that where the wing planform is shaped like an ellipse, that is where the wing chord varies elliptically along its span. In the 1940's many World War II fighters were built with elliptical planforms to try to minimize induced drag. The most famous of these was the British Spitfire aircraft.



Figure 1.33: The British "Spitfire" Airplane

It is possible to get an elliptical or near-elliptical lift distribution in other ways with the right combination of wing taper, twist, and sweep or by varying the airfoil section used as you go out the span. Some of these combinations can give values of induced drag coefficient at or near a minimum while minimizing the difficulty of building the wing. In some cases a complicated planform is required for other reasons such as "stealth" or minimizing the radar return of the aircraft. The B-2, "stealth" bomber, despite its "saw-tooth" shaped wing planform, has a nearly elliptical lift distribution.

Often twist is part of this scheme because it may also be needed for control in stall. Because the control surfaces used for roll control, the ailerons, are near the wing tips we want to design the wing so the outboard portion of the wing will not stall when the inboard section begins to stall. For this reason the part of the wing near the tip is often twisted to give it a smaller angle of attack than the rest of the wing. Some airplanes use different airfoil sections near the tip than on the rest of the wing for this reason.

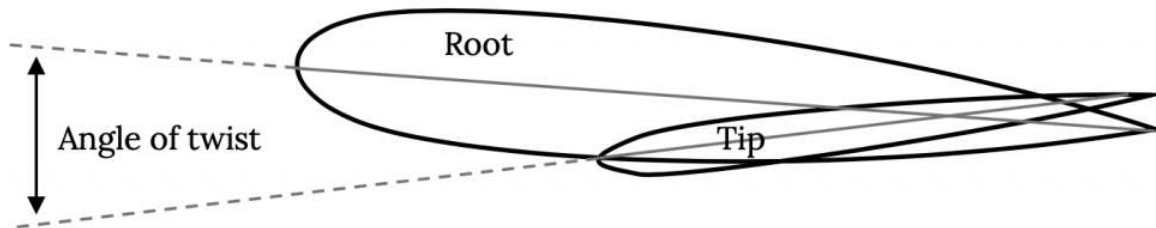

Figure 1.34: Often wings are twisted to keep the tip area from stalling when the inboard wing stalls, as well as to give a low induced drag lift distribution over the span.

It should be stressed that while the elliptical lift distribution is ideal aerodynamically there are other factors which must be considered when designing the wing. For example, another lift distribution may well be the optimum one for structural strength or for control responsiveness. The British Spitfire was a very efficient airplane aerodynamically because of its elliptical wing planform but pilots found that they could not roll the fighter as quickly as their German opponents in dogfights. As a result the beautiful Spitfire wing was “clipped” in later versions to allow greater roll rates because in the real world of aerial warfare maneuverability was found to be more important than aerodynamic efficiency and drag.

It should also be stressed that induced drag is only a portion of the drag. This “drag due to lift” is independent of other sources of drag such as friction between the air and the “skin” or surface of the aircraft or the “pressure drag” which comes from the normal variation of pressures around the airfoil. These other types of drag must be calculated from aerodynamic theory and “boundary layer” theory, the subjects of two courses later in the curriculum.

Homework 1

1. Write a calculator or computer program to find standard atmosphere conditions (pressure, temperature and density) for any altitude in the troposphere and stratosphere in *both* SI and English units. Turn in a listing of the program and a print-out for conditions every 1,000 meters (SI units) and every 1000 feet (English units) up to 100,000 feet or 30,000 meters.
2. A compressed air tank is fitted with a window of 150 mm diameter. A U-tube manometer using mercury as its operating fluid is connected between the tank and the atmosphere and reads 1.80 meters. What is the total load acting on the bolts securing the window? The relative density of mercury is 13.6.
3. On a certain day the sea level pressure and temperature are 101,500 N/m² and 25°C, respectively. The temperature is found to fall linearly with altitude to -55°C at 11,300 meters and be constant above that altitude.
4. An aircraft with no instrument errors and with an altimeter calibrated to ISA specifications has an altimeter reading of 5000 meters. What is the actual altitude of the aircraft? What altitude would the altimeter show when the plane lands at sea level?

References

Tables 1.1 and 1.2: National Advisory Committee for Aeronautics (1953). NACA-TR-1135 and NACA TN 1428. Retrieved from <https://ntrs.nasa.gov/citations/19930091059>

Figure 1.1: Kindred Grey (2021). “Airfoil Terminology.” CC BY 4.0. Adapted from James F. Marchman (2004). CC BY 4.0. Available from https://archive.org/details/1.1_20210804

Figure 1.2: Kindred Grey (2021). “Wing Planform Terminology.” CC BY 4.0. Adapted from James F. Marchman (2004). CC BY 4.0. Available from https://archive.org/details/1.2_20210804

Figure 1.3: Kindred Grey (2021). “Some Wing Planform Shapes.” CC BY 4.0. Adapted from James F. Marchman (2004). CC BY 4.0. Available from https://archive.org/details/1.3_20210804

Figure 1.4: Kindred Grey (2021). “A Typical Mechanical Sensitive Altimeter.” CC BY-SA 3.0. Adapted from WikiDot (2009). “Figure 4: The Mechanism.” CC BY-SA 3.0. Original: <http://aviationknowledge.wikidot.com/aviation:sensitive-altimeters>. Adapted: https://archive.org/details/1.4_20210804

Figure 1.5: James F. Marchman (2004). “Bernoulli’s Equation Example.” CC BY 4.0.

Figure 1.6: James F. Marchman (2004). “A Pitot Tube Measures Total Pressure.” [CC BY 4.0](#).

Figure 1.7: James F. Marchman (2004). “A Static Tube Measures Static Pressure.” [CC BY 4.0](#).

Figure 1.8: Kindred Grey (2021). “A Pilot-Static Probe.” [CC BY 4.0](#). Adapted from James F. Marchman (2004). [CC BY 4.0](#). Available from <https://archive.org/details/1.8-updated>

Figure 1.9: Kindred Grey (2021). “An Airspeed Indicator.” [CC BY 4.0](#). Adapted from Federal Aviation Administration Pilot’s Handbook of Aeronautical Knowledge. Public domain. Original available from https://www.faa.gov/regulations_policies/handbooks_manuals/aviation/phak/media/10_phak_ch8.pdf . Adapted available from: https://archive.org/details/1.9_20210804

Figure 1.10: Kindred Grey (2021). “Shock Wave Formation in “Transonic” Flow.” [CC BY 4.0](#). Adapted from James F. Marchman (2004). [CC BY 4.0](#). Available from https://archive.org/details/1.10_20210804

Figure 1.11: Kindred Grey (2021). “Drag Coefficient Increase Near Mach One.” [CC BY 4.0](#). Adapted from James F. Marchman (2004). [CC BY 4.0](#). Available from https://archive.org/details/1.11_20210804

Figure 1.12: NASA (1947). “Bell X-1 46-062 (in flight).” Public domain. Available from [https://commons.wikimedia.org/wiki/File:Bell_X-1_46-062_\(in_flight\).jpg](https://commons.wikimedia.org/wiki/File:Bell_X-1_46-062_(in_flight).jpg)

Figure 1.13: Kindred Grey (2021). “Flow Around a Circular Cylinder.” [CC BY 4.0](#). Adapted from James F. Marchman (2004). [CC BY 4.0](#). Available from https://archive.org/details/1.13_20210804

Figure 1.14: Kindred Grey (2021). “Drag Coefficient Variation with Reynolds Number for a Sphere.” [CC BY 4.0](#). Adapted from James F. Marchman (2004). [CC BY 4.0](#). Available from https://archive.org/details/1.14_20210804

Figure 1.15: Kindred Grey (2021). “Definition of the Pitching Moment Sign.” [CC BY 4.0](#). Adapted from James F. Marchman (2004). [CC BY 4.0](#). Available from https://archive.org/details/1.15_20210804

Figure 1.16: Kindred Grey (2021). “Relationship Between Lift, Drag, and Free Stream Velocity.” [CC BY 4.0](#). Adapted from James F. Marchman (2004). [CC BY 4.0](#). Available from https://archive.org/details/1.16_20210804

Figure 1.17: Kindred Grey (2021). “Plots of Lift and Drag Coefficient Versus alpha, Showing Stall (a).” [CC BY 4.0](#). Adapted from James F. Marchman (2004). [CC BY 4.0](#). Available from https://archive.org/details/1.17_20210804

Figure 1.18: James F. Marchman (2004). “Type of Pressure Distribution.” [CC BY 4.0](#).

Figure 1.19: SDASM Archives (2013). “Boeing 247.” [The Commons](#). Available from <https://www.flickr.com/photos/sdasmarchives/11343397173/>

Figure 1.20: Björn Strey (2009). “Douglas DC-2 (PH-AJU) in flight at the Bremen Airport Flugtag (3519224016).” [CC BY-SA 2.0](#). Available from [https://commons.wikimedia.org/wiki/File:Douglas_DC-2_\(PH-AJU\)_in_flight_at_the_Bremen_Airport_Flugtag_\(3519224016\).jpg](https://commons.wikimedia.org/wiki/File:Douglas_DC-2_(PH-AJU)_in_flight_at_the_Bremen_Airport_Flugtag_(3519224016).jpg)

Figure 1.21: Kindred Grey (2021). “Typical Leading and Trailing Edge Flap Effects.” [CC BY 4.0](#). Adapted from James F. Marchman (2004). [CC BY 4.0](#). Available from https://archive.org/details/1.21_20210804

Figure 1.22: James F. Marchman (2004). “The Clark Y Airfoil Shape.” [CC BY 4.0](#).

Figure 1.23: Kindred Grey (2021). “General effects of wing sweep on transonic drag rise.” [CC BY 4.0](#). Adapted from James F. Marchman (2004). [CC BY 4.0](#). Available from https://archive.org/details/1.23_20210804

Figure 1.24: Kindred Grey (2021). “Other Effects of Wing Sweep (a).” [CC BY 4.0](#). Adapted from James F. Marchman (2004). [CC BY 4.0](#). Available from https://archive.org/details/1.24_20210804

Figure 1.25: Kindred Grey (2021). “Supercritical Airfoil Shape.” [CC BY 4.0](#). Adapted from James F. Marchman (2004). [CC BY 4.0](#). Available from https://archive.org/details/1.25_20210804

Figure 1.26: Kaboldy (2012). “Convair F-102 Delta Dagger.” [CC BY-SA 3.0](#). Available from https://commons.wikimedia.org/wiki/File:Convair_F-102_Delta_Dagger.svg

Figure 1.27: Kindred Grey (2021). “Ideal (2-D) and Real (3-D) Lift Distributions on a Wing.” [CC BY 4.0](#). Adapted from James F. Marchman (2004). [CC BY 4.0](#). Available from https://archive.org/details/1.27_20210804

Figure 1.28: James F. Marchman (2004). “High AR wing on left has less area affected by flow around tip and, thus, less lift loss than the lower AR wing on the right. (a).” [CC BY 4.0](#).

Figure 1.29: James F. Marchman (2004). “Trailing Vortices.” [CC BY 4.0](#).

Figure 1.30: Kindred Grey (2021). “The “slope” of the lift curve decreases as AR decreases.” [CC BY 4.0](#). Adapted from James F. Marchman (2004). [CC BY 4.0](#). Available from https://archive.org/details/1.30_20210804

Figure 1.31: Kindred Grey (2021). “Downwash and Induced Drag.” [CC BY 4.0](#). Adapted from James F. Marchman (2004). [CC BY 4.0](#). Available from https://archive.org/details/1.31_20210804

Figure 1.32: Kindred Grey (2021). “An Elliptical Lift Distribution.” [CC BY 4.0](#). Adapted from James F. Marchman (2004). [CC BY 4.0](#). Available from https://archive.org/details/1.32_20210804

Figure 1.33: Kindred Grey (2021). “The British ‘Spitfire’ Plane.” [CC BY-SA 2.0](#). Adapted from Falcon Photography (2019). “Spitfire Belly Fairing.” [CC BY-SA 2.0](#). Original available from https://www.flickr.com/photos/falcon_33/48712711406/in/photostream/. Adapted available from https://archive.org/details/1.33_20210804

Figure 1.34: Kindred Grey (2021). “Often wings are twisted to keep the tip area from stalling when the inboard wing stalls, as well as to give a low induced drag lift distribution over the span.” [CC BY 4.0](#). Adapted from James F. Marchman (2004). [CC BY 4.0](#). Available from https://archive.org/details/1.34_20210804

<!-- pb_fixme --><!-- pb_fixme -->

This page titled [1: Introduction to Aerodynamics](#) is shared under a [CC BY 4.0](#) license and was authored, remixed, and/or curated by [James F. Marchman](#) (Virginia Tech Libraries' Open Education Initiative) via [source content](#) that was edited to the style and standards of the LibreTexts platform.

2: Propulsion

Introduction

In Chapter 1 we looked at the Standard Atmosphere, the environment in which aircrafts operate, at Bernoulli's equation and its relationship to airplane (or more specifically, wing) aerodynamics, and at some basic parameters that influence the aerodynamic performance of an airplane. In this chapter we will look at the way that we account for airplane propulsion; i.e., jet or propeller engines. This means we will be looking at the factors that affect things like airplane thrust and power. We will also find that the same factors that explain thrust can also be used to account for some of the drag on an airplane.

In looking at thrust, power, and drag we are interested in how these may vary with airplane speed and with altitude. We must have a basic understanding of these dependencies if we are to eventually use these in determining the performance of an airplane.

Airplane engines are, of course, the subject of entire engineering courses dealing with things such as internal combustion engines and air-breathing jet engines. We want to confine ourselves to a very simple approach to understanding how propulsion works without going into any more of the details than are absolutely necessary. Fortunately, we will be able to do this.

2.1 Jet Engines

Jet engines come in a wide range of designs. Most are considered "turbine" engines because turbines are used to extract energy from the high speed exhaust flow to drive a "compressor" to compress the flow into the engine prior to fuel addition and combustion, but at very high speeds (hypersonic flow) it is possible to get compression through shock waves and a non-turbine jet engine called a "ramjet" is the result. However, we are going to restrict ourselves to subsonic, incompressible flight where turbines and compressors are always needed.

The most basic type of jet engine is called a "turbojet" and it consists basically of an inlet, followed by a compressor that increases the pressure (and lowers the speed) of the air before it enters the combustion chamber where fuel is added and ignited. After combustion a turbine extracts enough energy from the high energy (high speed) exhaust products to drive the compressor, and the flow then exits through the engine exhaust at high speed to provide thrust.

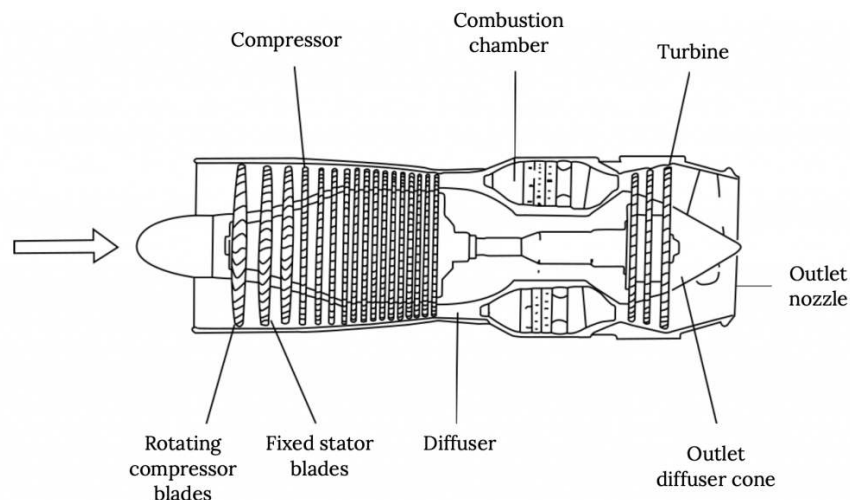

Figure 2.1: TurboJet Engine Illustration

It turns out that a pure turbojet isn't a very efficient way to make thrust. It creates thrust through a very high speed exhaust and this is both very noisy and very loss prone. The high speed exhaust jet essentially rips its way through the surrounding air and this violent interaction between exhaust and atmosphere results in a lot of friction-like losses and makes a lot of noise.

We will look at jet propulsion in terms of momentum changes (energy per unit time) with the difference between the momentum in the exhaust and the engine inlet accounting for the thrust and, at first glance, it will seem that any way we can get a change in momentum is just as good as any other way, but that is not the case.

Momentum is essentially the mass multiplied by speed (velocity). This means that there are two ways to get a momentum change. One is to take a small amount of mass and accelerate it to a very high speed as is done in a turbojet engine. Another is to take a large amount of mass and accelerate it by a lesser amount. As it turns out, the latter way is the most efficient way to get thrust. It is sort of like comparing the effects of a large ceiling fan rotating slowly with those of a little “personal” fan. If you made two propeller driven air boats of the type used in swamps, one boat with a small propeller and the other with a large one, you would find that the boat with the larger prop would need less power to move at a given speed than the one with the small prop.

Fan-jets rely on this principle to provide more efficient thrust to an airplane than turbo-jets. In a fan-jet, the engine turbine or turbines drive both the compressor that works on the air going into the combustion chamber and a large fan that adds momentum to a large mass of air going around the engine core without being used to burn fuel. This fan or “bypass” air then mixes with the higher speed core, combustion products to give a high momentum total engine exhaust that derives its momentum from the large mass of the bypass flow and the high speed of the core flow.

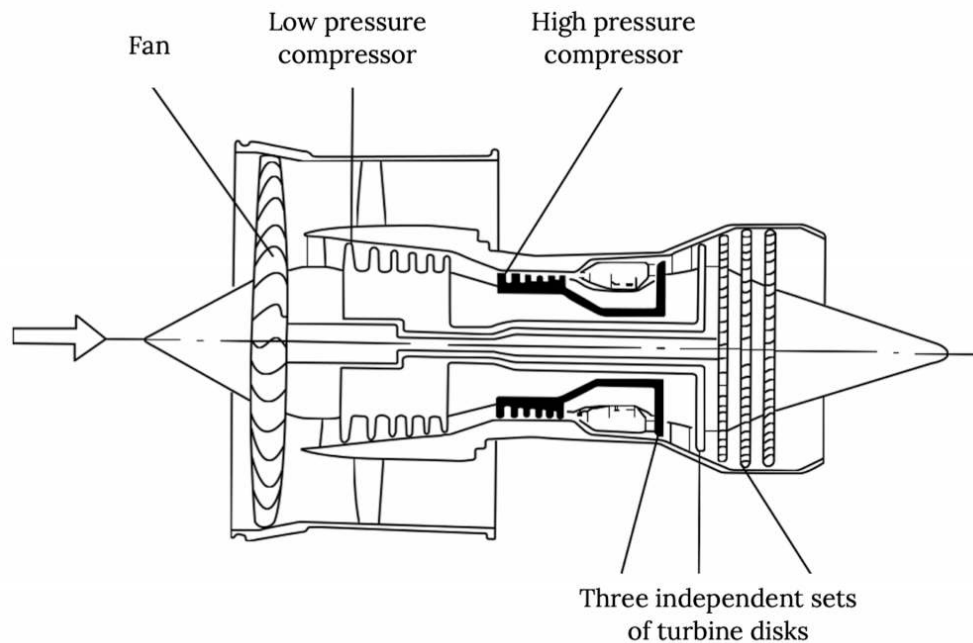

Figure 2.2: Illustration of a Turbo-Fan or Fan-Jet Engine

So, for a given amount of thrust we will need a given amount of momentum change of the air going through the engine between its entrance and exit. We will look at how this momentum change mathematically accounts for the thrust a little later. The point here is that the most efficient way to get this momentum change with minimal losses is to accelerate a large mass of air by a small amount (small change in speed). This means that the bigger the bypass ratio (the ratio of the bypass air mass to the mass of air going through the engine core) the more efficient the engine is. But there is a limit to this.

As the fan jet engine gets larger due to higher bypass ratio design, the engine enclosure (nacelle) also gets larger and it produces more drag. So at some point it makes more sense to replace the bypass “fan” with a large propeller. The result is the “turbo-prop” engine.

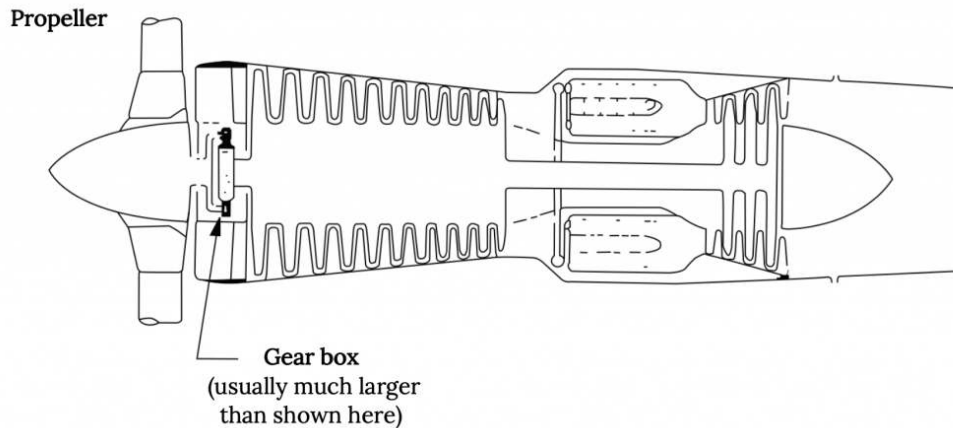

Figure 2.3: Turboprop Engine Illustration

In the turboprop engine the flow through the engine core is really not used to produce any significant thrust. The exhaust turbine is designed to take all of the energy it can from the exhaust to drive the propeller and all of the engine's thrust comes from the flow through the propeller. In a turboprop engine the amount of thrust that comes from the core flow is so negligible that, in some engine designs, the core flow actually goes "backwards".

We might wonder, if the turboprop engine is more efficient than the fan-jet, which is in turn more efficient than the turbojet, why fan-jets are the engine of choice for most airplanes today? The answer is in the desired speed of flight.

Just as there is a big drag rise on a wing as it approaches the speed of sound, there are drag type losses on a propeller blade when its speed approaches Mach one. In fact, for a given propeller rotation speed, the limit on practical diameter for the prop is determined by the radius at which the propeller blade section reaches its critical Mach number. And, since the airspeed seen by the propeller blades is a function of both their rotational speed and the speed of the airplane, this limits the speed of the aircraft. Propeller design can extend this speed range somewhat with things like swept blade tips but the turboprop will always impose limits on aircraft cruise speeds.

Also, it turns out that the rotational speeds needed for a turboprop propeller are an order of magnitude below those of those in an efficient turbine core and this necessitates speed reduction gears between the turbine and the prop and this introduces both noise and vibrations that are not found in the fan-jet.

2.2 Propeller Engines

So what is the difference between a turboprop and a propeller driven by an internal combustion engine? From the point of view of the thrust provided by the propeller, there isn't much difference. The difference is in the engine and the gearing that drives the propeller.

The turboprop is driven by a small turbine (jet) engine that sends as much of its energy as possible to the propeller through a driveshaft and reduction gear system. The IC engine propeller is attached to the driveshaft of an internal combustion engine that, like most automobile engines, uses the burning of gasoline or diesel fuel in a piston/cylinder type motor to turn the shaft.

Today most internal combustion driven propeller engines are found on smaller general aviation aircraft. This type of engine has provided reliable, affordable power for airplanes since the first flight of the Wright brothers in 1903. Over the years there have been many fascinating variations of IC engine used in airplanes, from the "rotary" engines of World War I in which the driveshaft was attached to the airplane and the propeller and engine actually rotated together around the shaft, to the massive piston engines of the 1940s and 1950s with dozens of cylinders arranged around the driveshaft like kernels on an ear of corn, to the four and six cylinder, car type but air cooled, engines usually found on today's GA airplanes. These many varieties of IC engines would make an interesting and exhausting study in themselves, but that is beyond the scope of this text.

As far as we will be concerned, a propeller engine is a propeller engine, whether driven by a turbine or an IC engine or a rubber band. We will merely be concerned with the "power" output by the engine and we will call this the "shaft power" regardless of the type of engine that drives the shaft.

2.3 Thrust and Power

This brings us to the main difference in the way we will talk about propulsion for jet and prop engines. For **jet** powered aircraft, whether turbojets or fanjets, we will characterize the propulsion properties of the airplane in terms of **thrust**. For **propeller** powered airplanes, whether the propeller is attached to an IC engine or a turbine, we will talk about performance in terms of **power**.

Power and thrust are merely two different ways of looking at aircraft propulsion and performance. They are directly related to each other through speed.

$$\text{Power} = (\text{Thrust})(\text{Velocity})$$

While we normally talk about jet propulsion in terms of thrust and propeller propulsion in terms of power, there is little reason beyond convention that we must do so. We could talk about the power of a jet engine and the thrust of a propeller and we sometimes do so. Perhaps one reason for this distinction is that we will later find it convenient to look at the variation of both power and thrust with velocity and we will find that it is common to assume that thrust is fairly constant with speed for a jet and power is fairly constant with speed for a propeller driven plane.

The units normally associated with power and thrust, respectively, are pounds and horsepower. Yes, these are “politically incorrect” units; nonetheless, they are far more widely used than Newtons and Watts, their SI equivalents. [Have you ever heard anyone talk about the power of their car engine in watts?] This, of course, means we need to learn how the unit of horsepower relates to basic units in the “English” system.

$$1 \text{ horsepower} = 550 \text{ foot-pounds} / \text{second.}$$

[A bit of engineering trivia: this conversion was used so often in the days of slide rule calculations that most slide rules had a special mark on them at the 550 location on the slide.]

2.4 Thrust and Conservation Laws

To find out how things like altitude and airspeed affect thrust and power we need to take a look at how the air goes through the propeller or the jet engine when an airplane is in flight and how the momentum of the air changes as it follows that path. To do this we will need to look at two “conservation laws”, conservation of mass and conservation of momentum.

2.4.1 Mass Conservation

In its simplest concept mass conservation is often stated something like “mass cannot be either created or destroyed; i.e., it is constant or conserved”. This is often accompanied by a qualifier noting that, in an atomic reaction, mass can actually be created (fusion reaction) or destroyed (fission reaction). This is an interesting way to look at mass if one is looking at the mass in the universe or in a closed container but it doesn’t help us when talking about engines. We need to look at the conservation of mass in a flow; that is, in the air going through a room or a pipe or a propeller or a jet engine.

If we had a sealed room filled with air it would be simple to state that the amount of air in the room is a constant. We could have people and plants in the room with the chemical reactions that are part of human breathing and plant chemistry continually altering the chemical constituencies in the “air”; nonetheless, the total mass of the “air” would remain constant.

The picture changes when we add ventilation to the room, either by using a forced ventilation system such as an air conditioning or heating system or by simply opening windows and doors. With either system there would be new air coming into the windows, doors, or intake vents and old air going out of other windows, doors, or exhaust vents. If we had a room with only a forced air inlet and no exhaust, the mass of air in the room would increase as air came in through the inlet. To accommodate this increasing mass the room would either have to expand like a balloon or the pressure and density of the air in the room would have to increase. Note that, if we assumed that the air was “incompressible” it would be impossible to pump new air into the room without providing an exhaust for an equal amount of air to escape. This would require conservation in the mass of the air in the room.

So in the example of room ventilation, conservation of mass for the air in the room would simply mean that, as a mass of new air enters the room, the same amount of mass of air must leave the room. Room or window air conditioners work this way, taking a given mass flow rate from the room, sending it through cooling coils, and returning that same mass flow rate to the room after some heat was removed from the air.

This brings us to the subject of mass flow rate, often called “m-dot” and given the symbol of a lower case “m” with a dot on top of the letter to represent a time derivative of the mass; i.e., mass per unit time, dm/dt .

When we speak of a room with vents or doors and windows we must talk about mass flow rates, and we say that in order to have mass conservation we must have no change in the mass within the room per unit time, simply another way of saying that the amount of mass that goes in during a given time period must equal the amount of mass that goes out in that same time. This is stated as:

$$dm/dt = 0 .$$

In other words, the amount of mass in the room does not change with time.

We often put this in equation form, saying that

$$dm/dt = \Sigma \rho VA = 0 .$$

Here, we are saying that the mass flow rate is equal to the density of the air, multiplied by its speed, as it passes through an area of size “A”. In other words, if air at sea level density is blowing through a window at a speed of 20 feet-per-second and if that window has an opening of 2 feet by 4 feet, we can calculate the mass of air per unit time that is passing through the window.

$$dm/dt = \rho VA = (0.002378 \text{ sl/ft}^3)(20 \text{ ft/sec.})(2 \text{ ft} \times 4 \text{ ft}) = 0.3805 \text{ sl/sec.}$$

[Note here that the units of mass rate of flow have been found to be *slugs per second*. In the SI system they would be found in *kilograms per second* and in a version of the “English” system often used in fields such as Mechanical Engineering the units of mass flow rate would be *pounds-mass per second*.]

Now, if conservation of mass is met for the air in the room, the same mass of air per unit time must be going out of another opening or openings.

$$(dm/dt)_{in} + (dm/dt)_{out} = 0$$

or

$$(\rho VA)_{in} + (\rho VA)_{out} = 0$$

So, if there is a single window letting in the air flow found above and the exit is through a door, we can use conservation of mass to determine the speed of the air going out the door.

$$(\rho VA)_{out} = - (\rho VA)_{in} .$$

Just as three factors, the size (area) of the window, the speed of the air flow through the window, and the density of the air, determined the “mass flow rate” of the air coming into the room, the same three things determine the exit mass flow rate. In reality, all three of these things could be different at the exit (door, in this case), so, if we want to find the speed of the exiting air we must know both the area of the door and the density of the air at the door. However, there is no reason why the air flowing through the room would have changed density so we are safe in assuming “incompressible” flow, that is, density is constant. This gives us a simple equation:

$$(VA)_{out} = - (VA)_{in} .$$

So, if the door is 3 feet wide by 7 feet high, giving an area of 21 ft², while the window had an area of 8 ft², the speed of the air going out the door is:

$$V_{out}/V_{in} = - A_{in}/A_{out}$$

or

$$V_{out} = - V_{in}(A_{in}/A_{out})$$

or in this case,

$$V_{out} = - 20 \text{ ft/sec.} (8 \text{ ft}^2 / 21 \text{ ft}^2) = - 7.62 \text{ ft/sec.}$$

Now, why is there a minus sign with the exit velocity? This is because we, for no real reason, chose to give a positive sense to the velocity going in the window and since velocity is a vector; i.e., it has a direction, we have designated the flow of air into the room

as positive. This means that the negative sign on the exit air velocity tells us it is going out of the room. While this may seem like an un-needed complication here, there are cases where it can help us figure out what is happening.

For example, suppose there are five windows and two doors in our room and we are told that air is coming into all five windows at a certain speed and is going out one door at a given speed, what is happening at the other door? Is the flow through that second door going into or out of the room?

We would have to write the complete equation for mass flow conservation to find both the amount and direction of the flow through the second door.

$$(\rho VA)_{w1} + (\rho VA)_{w2} + (\rho VA)_{w3} + (\rho VA)_{w4} + (\rho VA)_{w5} - (\rho VA)_{D1} + (\rho VA)_{D2} = 0 .$$

Note that we have assigned *positive* values to the flow through all the windows since we were told that the flow was coming *into* all of them. We have also assigned a *negative* value to the flow out the first door since the flow was said to be *out* of that door. Also note that we did not assign a sign (direction) to the flow through the second door because we have no idea which way it is going. Now, if we put all the needed information for the five windows and first door into the terms in the equation and if we know the area of the second door and assume that density is the same everywhere (incompressible flow), we can solve for the speed (velocity) of the flow using the mass conservation relationship above and find both the magnitude of the speed and its direction (sign).

Exercise 2.1

Try doing the above problem assuming that all five windows are 2 ft X 4 ft in size and that air is blowing in at 20 ft/sec.

Assume that the two doors are both 3 ft X 7 ft in size and that the flow out of the first door is measured at 50 ft/sec.

Find the speed and direction of the flow through the second door.

NOTE: Here we considered all flow *INTO* our “system” or “control volume” as *POSITIVE*, and all flow *OUT* of the system as *NEGATIVE*. If we do not know its direction, we assume it is positive in value and the solution of the equation will give us a negative answer if we assumed the wrong direction. Later, when we look at the Momentum Equation we will use a unit vector, \mathbf{n} , to assign a positive direction within our chosen axis system for flow through an opening, and that unit vector will always point *OUT* of the system.

OK, that was simple enough, but how do we deal with mass conservation when we are looking at flow through a jet engine or a propeller?

Mass conservation through a propeller or a jet engine works just like mass conservation in a flow going through a room. In fact, for the jet engine it is even simpler than the average room because there is only one well defined entrance and exit, *or is that really the case?*

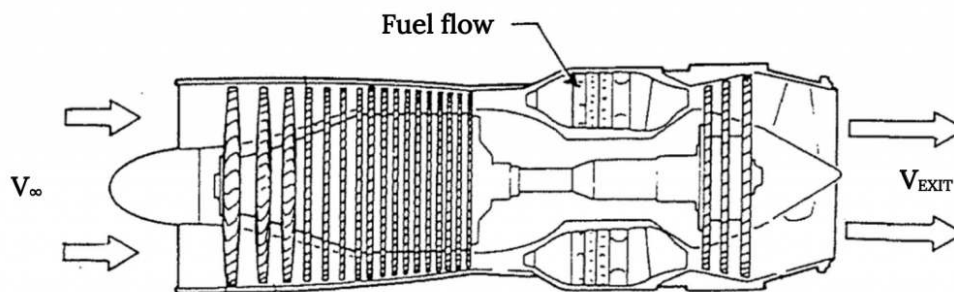

Figure 2.4: Mass Flows for a Turbo-Jet Engine

Technically, there is a second source of incoming mass in any jet engine and that is the mass flow of fuel coming into the engine. There is air coming into the engine inlet of a known area at (supposedly) a known speed and density, but the flow going out of the engine isn't really just air, it is the gas that comes from combustion of the incoming air and the incoming fuel. The mass rate of flow coming out of the exit must account for both the mass of the entering air and the entering fuel, so our mass conservation relationship must recognize this.

$$(\frac{dm}{dt})_{inlet} + (\frac{dm}{dt})_{fuel} + (\frac{dm}{dt})_{exhaust} = 0$$

We would normally write this as:

$$(\rho AV)_{\text{inlet}} + (dm/dt)_{\text{fuel}} = -(\rho AV)_{\text{exhaust}}$$

So we must know the mass flow rate of the fuel. Usually the mass flow rate of the fuel is very small compared to that of the inlet air so perhaps that term can be neglected. So what's the big deal? If we can neglect the fuel flow rate we are back to the one window, one door example and life is easy. Unfortunately there is another factor that we must not forget and that is density. Usually the flow through the exhaust of a jet engine is going pretty fast, near or greater than the speed of sound; i.e., *we can no longer assume that density is constant as we did in the room ventilation example.*

To solve this problem we have to know either the exit flow density or its speed in order to solve the equation for the “other” parameter (exit speed of density), and since the fuel mass flow contributes to this exit density we probably should not assume it to be negligible even if its velocity is almost negligible.

Making mass conservation for a jet even more complex is the fact that most of today's jets are “fan jets” where there are essentially two entrance flows, one that goes through the engine core, mixing with the fuel to form a high speed exhaust, and another, larger, flow that is accelerated through the fan. We might analyze this problem by accounting for two separate entrance flows and two separate exit flows, or by assuming (correctly in most cases) that the two exit flows mix before leaving the engine covering or “nacelle” to form a single, mixed exhaust.

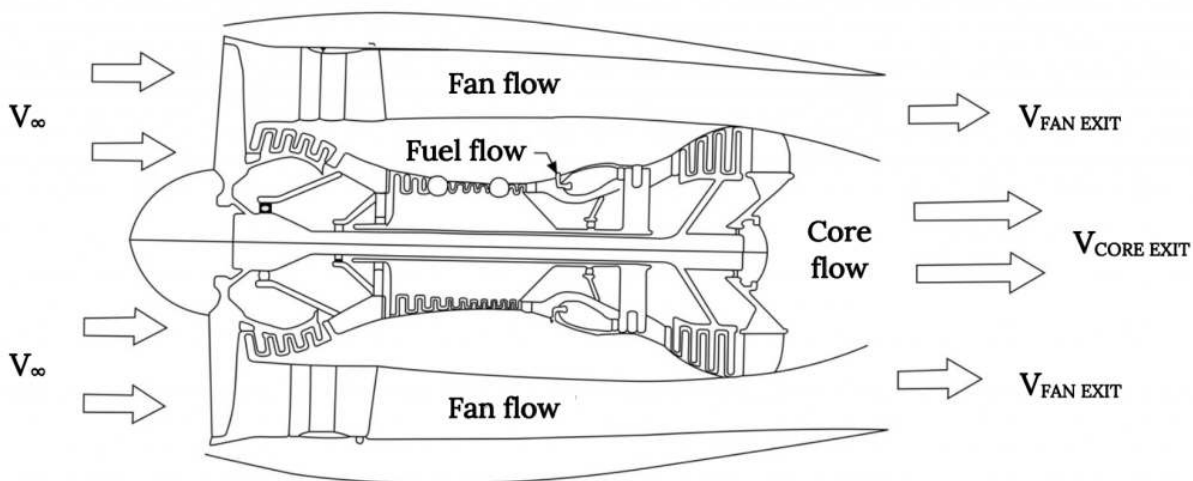

Figure 2.5: Flows Through a Fan-Jet Engine

In any case, the jet engine flow problem is a little simpler for many people to understand than the propeller flow problem because the entrance and exit areas are normally pretty well defined. How do we define entrance and exit flows when we draw the flow through a propeller?

When a flow is going through a propeller, just what are the entrance and exit areas? There really is no physical entrance or exit. Of course, we know the flow goes through the propeller itself, so, is the propeller area used for both the flow “entrance” and its “exit”? This hardly makes sense. How can we talk about the changes in the flow between the entrance and exit when there is no physical distance between the entrance and exit?

Let's look at what we know intuitively about the flow through a propeller (or a fan). We know that the flow behind the propeller or fan is moving faster than the flow in front of it. We know that in some way, a way that can be analyzed in detail by looking at each propeller or fan blade as a little rotating wing that does work on the air, the propeller essentially adds energy to the flow. We also know, if we think about it a bit, that *we cannot use Bernoulli's equation to compare the flow upstream and downstream of the prop or fan because energy is added at the prop or fan and Bernoulli's equation assumes that energy is constant through the flow.* We also know that there are limits to what a fan or propeller can do to accelerate a flow due to tip speed limits on the blades themselves and these limits essentially mean that we can pretty safely assume incompressible flow through the system.

Putting all these facts together, we can draw a picture that looks something like the flow should appear through a propeller or fan. We know that somewhere upstream of the propeller the flow is undisturbed; i.e., it is at “free-stream” or atmospheric conditions.

We know that somewhere downstream of the prop the static pressure in the mass of air that went through the propeller must return to its free-stream value.

We will imagine a “stream-tube”, or three-dimensional path of constant mass flow, that starts out in the undisturbed flow upstream of the prop, goes through the prop (becoming the same diameter as the prop at that location, and then continues downstream until the point we mentioned above where the static pressure has returned to the atmospheric value. What must that “stream-tube” look like?

A stream-tube is defined as a three-dimensional flow path in which the mass flow rate is the same at every point along its journey. Essentially, as shown in the following figure, the upstream cross sectional area of the stream-tube (its “capture” area) must have the same amount of mass flow rate through it as goes through the prop itself. Likewise, the “exit” area for our stream-tube must also allow passage of the same mass flow as went through the capture area and the prop “disk” area.

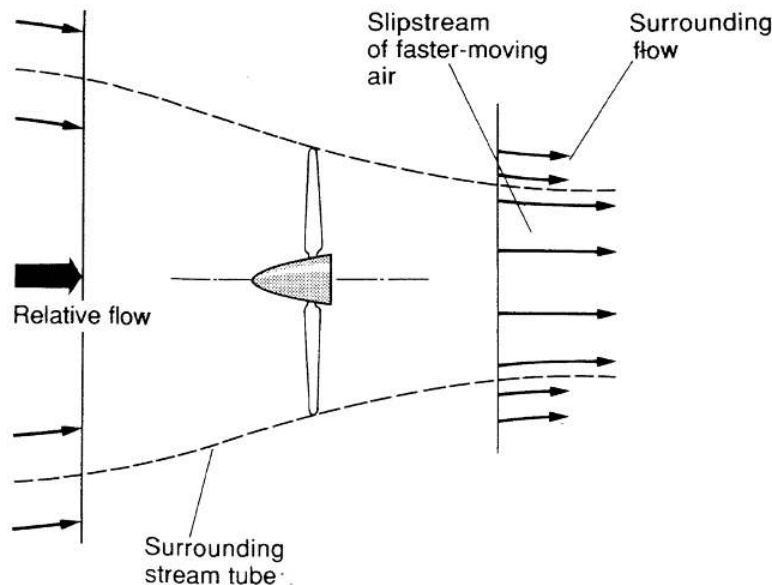

Figure 2.6: The Stream-tube Concept for a Propeller Flow

So why is the “stream-tube” in the figure above getting progressively smaller as the flow goes from the atmospheric pressure, free-stream capture area to the atmospheric pressure exit area somewhere downstream? First, we know the velocity in the exit area must be larger than in the capture (inlet) area; hence, if mass flow rate is the same and the flow is incompressible, the area must decrease in inverse proportion to the speed increases. But why do we assume that this area decrease (and speed increase) is smooth and continuous? Isn’t there simply a big jump in speed across the propeller disk?

Well, we probably could analyze everything in terms of some kind of instantaneous jump in flow speed at the propeller disk based on an energy balance, assuming that the energy added by the prop produces a sudden increase in flow kinetic energy and speed. However, we know from real world measurements that this speed increase is not instantaneous and that part of the increase is seen in front of the propeller as the flow speeds up from its “free-stream” velocity to the velocity right at the front of the prop disk. We also know that it takes a couple of propeller diameters downstream before the flow in the “propwash” reaches top speed. Based on this combination of reality and convenience, we choose to model the speed increase as a continuous one within a “stream-tube” shaped like a converging nozzle of circular cross section, as shown in the figure above.

This ideal picture, of course, ignores a lot of things such as the losses due to turbulence and rotational flow effects; nonetheless, it is one that works fairly well. So, what do we propose to do with this model and with the model of the flow through a jet engine? What we want to do is use these to determine how thrust is produced and find the properties that determine how thrust varies with speed and altitude.

2.4.2 Thrust

Our goal is to take a look at propulsion. How do we account for thrust or power in aircraft performance evaluations?

There are two ways to do this. One would look at energy additions to the flow and a conservation of energy. But, as noted in the propeller discussion above, this would be very tedious, requiring us to do aerodynamic analyses of each propeller blade, accounting for losses due to compressibility effects near the blade tips and for the interference between the flow over one blade and the following blade. There are books on how to do this, the oldest of which went under titles such as “Aircsrew Theory”, and this is the type of analysis that companies making propellers must use. The problem would be even more interesting in a jet engine with us having to account for energy gains and losses due to flow around compressor blades and turbine blades, combustion of fuel, and flow through internal nozzles.

It turns out that the simplest way to look at thrust is to look at momentum conservation.

2.4.3 Momentum conservation

Momentum conservation, like mass conservation and energy conservation, is one of the “big three” conservation “laws” that we all saw somewhere back in some Physics course. On the face of it, conservation of momentum is a simple concept. Just as in mass conservation of a flow we must account for all mass flows that enter or leave the flow-field under consideration, in looking at momentum conservation we must consider all things that could possibly account for momentum changes and, ultimately, in forces.

Essentially, the concept we are looking at is one that says that the change of momentum in a body or “system” with time must equal the forces on that body or system. The idea is that either forces on a body or system will cause its momentum to change or a momentum change within the system or body will result in a force.

$$\frac{d}{dt}(\text{momentum}) = \frac{d}{dt}(mv) = \text{Force}$$

This is a simple idea that is often made to look very complicated when derived in most textbooks on fluid mechanics. If, for example, you kick a soccer ball, the force you impart to the ball will result in a change in momentum in the ball. If the ball was standing still before it was kicked, the force will change its momentum from zero to a value related to the force of the impact and the mass of the ball. If the ball was already moving, the kick may send moving in another direction, so this concept is directional; i.e., it is a vector concept, as would be expected when a force is involved.

In looking at aircraft propulsion we are interested in the reverse action; that is, creating a momentum change in order to get a force, changing the momentum of the flow through the engine or propeller to create thrust.

Just as in working with Bernoulli’s equation we had a choice of modeling the flow as a moving fluid going past a wing or body, or as a body moving through still air, we have to make a similar choice here. We will, for example, choose to look at the flow through a jet engine or a propeller as if the engine (prop) is standing still and the flow is moving past it. This is really a choice between having to consider the momentum of the moving engine or the momentum of the moving air. Either view will give the same answer for the thrust, but the moving air model is usually a little easier to work with. Either way, we must be very careful to account for all possible momentum changes in both the engine and the flow.

We first need to look at what kinds of momentum changes might be present as well as what kinds of forces might be involved. To do this, let’s look at one of the simplest of “jet” engines, but one of the hardest to analyze, a rubber balloon that is inflated and released.

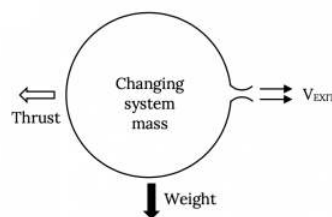

Figure 2.7: A Balloon as a Simple Jet

Let’s look at the illustration above and list all of the ways that momentum might play a role as well as all the forces involved. There will be at least two sources of change of momentum for the balloon and at least three forces that might be involved.

Momentum change sources:

1. The change in momentum of the balloon (the “system”) with time because of the change in mass of air inside the balloon with time and due to any changes in velocity of that mass. [As the balloon expels air through its inlet/outlet, the mass of the “system” itself is changing and, even if its speed was constant, the momentum of the system would change.]
2. The momentum of the flow exiting the “system” (balloon); i.e., the mass flow of air through the inlet/outlet (jet) multiplied by its velocity.

Both of these terms above are directional because of the velocities associated with them. The momentum of the balloon itself is related to the balloon’s velocity and the momentum of the flow through the exit is obviously related to the direction of the flow through the exit.

Forces on the balloon:

1. The major force on the balloon will be the one we choose to call **thrust**. This is essentially what we are trying to find.
2. nother force on the balloon that we might not think of at first is that due to gravity; i.e., its **weight**.
3. Finally, there would be any **pressure forces** caused by pressures acting on areas. These might include pressure drag on the balloon itself or differences in pressure across system boundaries. Often we find that pressure forces tend to balance out or sum to zero but there are some cases where these must be considered.
4. We could also consider friction forces or even electromagnetic or other forces if we wished but we will limit ourselves to the first three forces mentioned above.

How do we describe each of these sources of momentum change or forces in a very general way? Let’s look at each of these listed above.

1. The change in momentum of the “system” with time involves the changes in both mass and velocity of the system:

$$d/dt [(mass)(velocity)] ,$$

and, since the system mass can be written as its density times its volume, we might look at this as

$$d/dt [(density)(volume)(velocity)]$$

2. The change in momentum due to the flow out of (and in general) into the system with time is essentially the mass rate of flow (dm/dt) across any entrances or exits multiplied by the speed at which that mass is passing through the entrance or exit areas. We know that the mass rate of flow is the density multiplied by both the velocity and the flow cross sectional area, so this term is expressed as:

$$(dm/dt)(velocity) = (density)(velocity)(area)x(velocity) .$$

3. The weight is just the mass (density x volume) multiplied by the acceleration of gravity.

$$(density)(volume)(g) .$$

4. The pressure forces are just pressures acting on an area:

$$(pressure)(area)$$

Now, to work with all these we need to put them together in the form of some kind of equation. The equation must essentially say that the momentum changes must be balanced by the forces involved. This can be thought of as forces causing momentum change (the soccer player’s foot kicks the ball) or momentum changes causing forces (the thrust from a released balloon). The equation that usually results from a much more formal derivation is a complicated looking, vector relationship called the **momentum equation**.

2.4.4 The Momentum Equation

$$\underbrace{\frac{d}{dt} \iiint_R \rho \vec{V} dR + \iint_s \rho \vec{V} (\vec{V} \cdot \hat{n}) dS}_{\text{momentum change in fluid}} = \underbrace{-F_e - \iint_S \rho \hat{n} ds + \iiint_R \rho \vec{g} dR}_{\text{Forces causing momentum change}}$$

Before you panic at the vector notation and the double and triple integrals, take a deep breath and see how these terms relate to the ones presented above.

A triple integral over “R” (the mathematical “region” or the “system”) is nothing but the volume. If the density and velocity of everything contained in the region or system is the same; i.e., if it is a *homogeneous* system, then this term is nothing but the time derivative of the density times the volume times the velocity; i.e., of the system mass times its speed as it was stated in the section above.

So why do we make it so complicated looking? One reason might be just to impress our friends in liberal arts or to show our parents how hard our courses are. A better reason is to allow the momentum equation to account for non-homogenous system effects. Suppose, for example, that our “system” was not a balloon filled with nice homogenous air, but a baseball or golf ball with a solid filling made of several layers, each with different densities, and further, that someone had made the ball with its heavier core somewhat “off center”. You can buy such “trick” golf balls at novelty shops and when you hit them with a golf club (impart a force to the system!), instead of traveling in a straight line they wobble around as if they were drunk. Because the momentum equation can account for this “non-homogeneity” it can account for the wobbly motion of the trick golf ball. In a similar way the last term on the right, the gravity or weight term, can account for gravitational effects on a non-homogeneous mass.

Two of the terms in the equation have double integrals. You might have guessed by now that the double integral over a distance “S” must relate to some kind of area, and looking at the terms would confirm that. The double integral term on the left relates to the momentum carried with a flow into or out of the system over an entrance or exit area. This term is written in this complex way to be able to account for non-uniform velocities over the entrance or exit and even for non-uniform densities over these areas. If we assume that all of the entrance or exit flow is the same fluid moving at the same speed then the density and velocity terms can come outside the integral and the integral itself becomes nothing but the entrance or exit area. So, again, why make it look this complicated? Well, in many cases the flow out of an opening is not uniform because friction forces cause it to move more slowly near the edges of the opening than at the center, and this comprehensive form of the momentum equation can account for that if we want it to do so. Similarly, the pressure term on the right hand side of the equation can account for pressure variation over a surface.

What about the vector notation, the $\mathbf{V} \cdot \mathbf{n}$ term, in the double integral term on the left? First, the momentum equation is a vector equation, meaning that each of the terms has a direction and the solution of the equation for a force such as thrust or drag will give both a magnitude and a direction for that force. Second, for one of the terms on each side of the equation, it is only the parameter “normal” to a defined surface or boundary that will cause a force and the “unit vector” \mathbf{n} is used to designate that normal direction. We will always define the direction for this unit vector as pointing *out of the system*, even where the flow is coming into the system.

What then do these vector quantities mean? Each of the velocities can have up to three terms in them, one associated with each direction in a selected axis system. In the case of velocity in a conventional x, y, z axis system, we normally use the terms u, v, and w to designate the x, y, and z components of velocity, respectively. So we would write a velocity vector as:

$$\mathbf{V} = u\mathbf{i} + v\mathbf{j} + w\mathbf{k},$$

where \mathbf{i} , \mathbf{j} , and \mathbf{k} are the unit vectors in the positive x, y, and z directions. In a similar manner, the gravity vector could have up to three components; however, we sometimes try to define our coordinate system so one axis is in the direction of gravitational acceleration to eliminate two of these components.

The $\mathbf{V} \cdot \mathbf{n}$ term is then the “dot product” of two vectors where both the \mathbf{V} and the \mathbf{n} vectors may have x, y, and z components, but only the *like directed* components multiply with each other, then sum to give a “scalar” quantity with a magnitude but no direction. So, if the velocity is in the same direction as the normal vector (as is often the case for flows into or out of a system) the result is simply the magnitude of the velocity. At the other extreme, if the velocity is at a 90 degree angle to the normal vector the dot product gives zero.

Again one might ask, why make things so complicated with all these integrals and vectors and dot products and the like? It is done this way because it is a very versatile equation that can account for fully three dimensional motion. For example, should that soccer player kick the ball at a 90 degree angle to its existing direction of motion, this relationship would, provided we knew the force of the kick and the mass and velocity of the ball, tell us the ball’s new direction and speed even though the direction would be in neither the original direction of motion or in the direction of the kick. Similarly, if there is a bend in a pipe we can use the equation to find the magnitude and direction of the force that will occur when water flows through that bend in the pipe.

The trick to using the momentum equation is to follow the rule of thumb that often distinguishes an engineer from a pure scientist or mathematician; that is to use proper alignment of axis systems and to set system boundaries and to make good assumptions that will eliminate as much of the complexity as possible. Fortunately we can do a lot of this as we use the momentum equation to look at thrust.

2.4.5 Thrust (again)

Let's look at the flow through a jet engine in terms of the momentum equation.

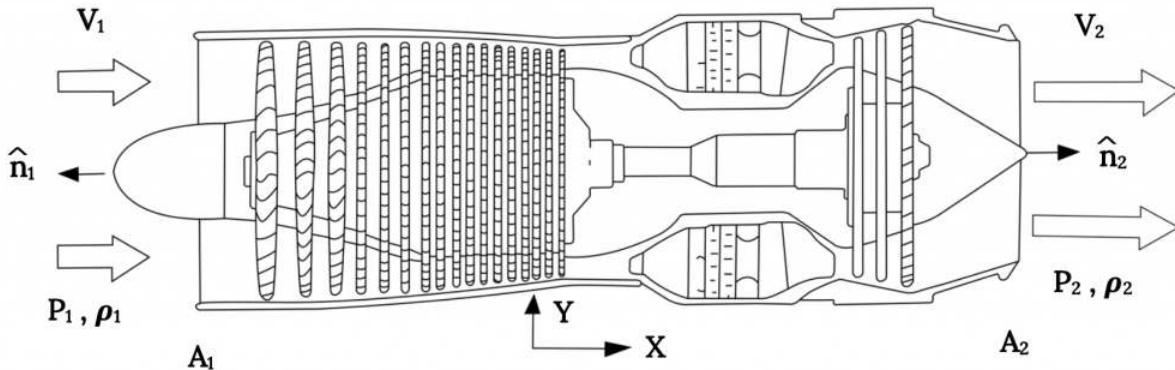

Figure 2.8: Momentum Equation Terms for Turbo-Jet

In the illustration above we have aligned the engine with the “x” axis and we have flow coming into the engine inlet in the x direction and another flow coming out of the engine, also in the x direction. We want to know the thrust as a function of this information. Let's look at what we can say about the various terms in the momentum equation.

The **first term on the left hand** side of the equation is a “time dependent” term to account for changes in momentum of the “system” itself with time. Here our system is the entire jet engine, and, if we assume that the engine (airplane) is in “steady” or constant speed flight, there is nothing in the term (density, velocity, or volume) that is changing with time. So, **this term is zero.**

The **second term on the left** accounts for the momentum carried into or out of the system as flow enters or leaves. Obviously, this term will not go away since we have air coming into the engine and combustion products going out the other end. First we need to ask if these two flows are “uniform” across their respective entrance or exit areas. If we can assume that they are uniform and can assume that all of the flow has the same density, then this term (actually two terms, one for the entrance and one for the exit) becomes:

$$\rho_1 V_1 (V_1 \cdot \hat{n}_1) A_1 + \rho_2 V_2 (V_2 \cdot \hat{n}_2) A_2 .$$

Now, what do we do with the vector business? The flows are both in the positive x direction. The first normal unit vector is in the negative x direction while the second is in the positive x direction. The result is:

$$-\rho_1 V_1^2 A_1 + \rho_2 V_2^2 A_2 , \text{ (all in the x direction)}$$

Ok, that takes care of the left hand side of the momentum equation. What happens to the terms on the right? The **first term on the right** is the “external” force which, in this case, is the thrust we want to find. The second term on the right is perhaps the hardest to understand physically so we will come back to this.

The **third term on the right** is the gravity term, really the weight. If we assume that this is acting at a 90 degree angle to the x axis or the direction of flight and thus is perpendicular to all the other forces and momentum changes in which we have an interest we might simply neglect this term. Actually it would be more proper to say that its component in the x direction is zero. *In reality, this term would tell us that there must be a force to oppose the weight and this would be the aerodynamic lift which, in turn, would be related in the momentum equation to a vertical change in momentum of the flow as it moved around the wing and the corresponding pressure distribution around the wing. In essence we are choosing to ignore the vertical components of the forces and momentum changes.*

Now let's go back to the **second term on the right**, the only term with pressures in it. This term looks at forces caused by pressures acting on areas. If we were looking at the lift force we would use this term to integrate the pressure distribution around a wing. On

the engine we will assume that the flows over the outside of the engine casing or nacelle are symmetrical, that is that the same pressure distribution exists on the top as on the bottom of the nacelle, and that the net effect of these pressures (at least in the x direction) is zero. But what about pressures across the entrance and exit?

Pressures across the entrance and exit?!! How can this mean anything when there are no real surfaces here, just flows going in or out? This is where the concept of a “system” boundary gets interesting. When there is a real boundary such as the engine nacelle the bounds of the system are easy to understand. But these “open” ends of the “system” are also boundaries over which we must account for all the terms in the equation. In other words, just as we had to account for the flow through these somewhat imaginary boundaries, we must also account for pressure changes across them. But how can these pressures cause real forces when there are no “real” surfaces for them to act on? This becomes one of those “leaps of faith” that we often must take in applying equations to physical situations.

No, there are no surfaces at the entrance and exit where the pressure differences across the surface cause a force; however, we must account for them anyway if there is a pressure differential between the surrounding atmosphere and the flow into the entrance and out of the exit. This is probably the easiest to understand when we look at the exhaust flow.

Coming out of the exhaust is a flow of the combustion products of air and fuel that has been heated and pressurized in the engine combustor. After combustion we want to turn that added energy into as high a momentum (the second term on the left hand side of the momentum equation) as possible. This means that we want to “expand” the gas in a exit nozzle, lowering its pressure with a corresponding increase in speed (ala Bernoulli’s equation) as much as possible to get a high momentum. The ideal situation is to expand it to the point where the exiting gas has the same pressure as the atmosphere into which it will exit. If it expands too much or too little there will be losses as the flow pressure comes to equilibrium with the atmosphere. It turns out (and the momentum equation essentially tells us this) that the losses from over or under-expansion are equivalent to the pressure force that would be on a surface with the same area as the exit with a pressure difference equal to that under or over-expansion ΔP . This is why some high performance jets have variable area exit nozzles on their engines.

The same problem can occur to a lesser degree at the engine inlet but a properly designed engine inlet and compressor section can eliminate most of the loss.

So, how do we deal with this pressure term? We either must know the differences between the atmospheric pressure and those of the entrance and exit flows and compute values for these terms, being careful to account properly for the unit vector signs, or we must assume that these losses are negligible. Let us take the easy way out and assume that these terms are of little consequence because we have a properly designed engine.

OK, where does this leave us? We have ended up with a relatively simple equation:

$$-\rho_1 V_1^2 A_1 + \rho_2 V_2^2 A_2 = -F_e$$

rearranging this gives:

$$\text{Thrust} = F_e = \rho_1 V_1^2 A_1 - \rho_2 V_2^2 A_2 .$$

Looking at this we see that the second term on the right will be much greater than the first term, so, the thrust will have a negative sign. Is this ok? Sure it is. It just says the thrust force is in the negative x direction, toward the left, just as we want it to be.

Wow! That sure was a lot of work to get a fairly obvious answer; the thrust is equal to the momentum change from engine inlet to exit! Isn’t this somewhat intuitive? Yes, it sortof is intuitive to many of us. On the other handit does keep the mathematicians and theoreticians in our midst happy, and more importantly, it tells us that in arriving at this “intuitive” answer we have made some important assumptionsabout pressure behavior and axis system selection, etc.

Ok, now that we have all that under our belts what important facts about propulsion can be drawn from this solution? To see this, let’s play around with the equation above a little by accounting for conservation of mass.

Now, recognizing that V_1 is our “free stream” speed, V_∞ , and that the entering air density is also that of the atmosphere, ρ_∞ , we can write this as

$$\text{Thrust} = \rho_\infty V_\infty^2 A_1 - \rho_2 V_2^2 A_2$$

And looking only at the magnitude of the thrust (as said above, the relationship above gives a negative thrust, signifying simply that it is to the left in our original illustration of the engine moving from right to left)

$$\text{Thrust} = \rho_2 V_2^2 A_2 - \rho_\infty V_\infty^2 A_1$$

We now define the “static thrust” as T_0 , the thrust when the engine is standing still ($V_\infty = 0$). This is the amount of thrust that would be measured on an engine test stand and is a standard piece of information that would exist for any engine.

$$T_0 = \rho_2 V_2^2 A_2$$

This allows us to rewrite the general thrust relationship as:

$$\text{Thrust} = T_0 - \rho_\infty V_\infty^2 A_1,$$

or simply as:

$$T = T_0 - a V_\infty^2,$$

where:

$$a = \rho_\infty A_1$$

What does all this tell us? First, all the thrust equations tell us that thrust is a function of the atmospheric density. Unlike velocity, which we earlier found to vary with the square root of density, thrust decreases in direct proportion to the decrease of density in the atmosphere. Thus, we write:

$$T_{\text{alt}} = T_{\text{sl}}(\rho_{\text{alt}}/\rho_{\text{SL}})$$

This is an important relationship between thrust and altitude that we will use in all performance calculations.

Second, we learn that, in general, ***the thrust of an engine varies with speed according to the relationship:***

$$T = T_0 - a V_\infty^2$$

It should be noted, as always, that these equations involve important assumptions, such as the assumption that engine exit pressure and entrance pressure are both equal to the pressure in the free stream atmosphere. Pilots of jet aircraft will tell you that the thrust to static thrust relationship shown above doesn't, for example, account for an engine surge on initial acceleration down the runway as a “ram effect” into the engine inlet occurs. This “ram effect” is essentially one of these pressure effects that we chose to ignore.

2.4.6 Propeller Thrust

It should be noted that we would get essentially the exact same thrust equation looking at the flow through a propeller as we do with a jet engine. Keeping in mind an earlier discussion, we would draw our “system” as shown below using boundaries that represent a “stream tube” of constant mass flow. In this case we have no easy way of knowing the exact values for the entering flow area or the exit area but we would get exactly the same equation as we found for the jet and we would still find

$$T = T_0 - a V_\infty^2.$$

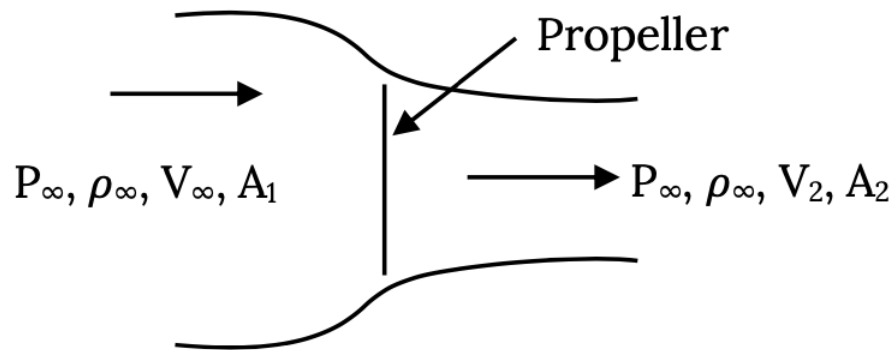

Figure 2.9: Momentum Equation Terms for Propeller Flow

In this chapter we have looked at the relatively simple models of aircraft propulsion that we will use in examining aircraft performance. In doing this we have used some basic physical concepts of conservation (mass and momentum), both of which can provide very powerful tools for evaluating forces and motions in fluid flows and other areas. We made a lot of simplifying assumptions along the way in order to understand some very basic concepts related to jet and propeller propulsion; in particular, to give a basis for modeling the way both thrust and power vary with speed and altitude. We will find these concepts very useful in later chapters.

Homework 2

1. In a wind tunnel the speed changes as the cross sectional area of the tunnel changes. If the speed in a 6' x 6' square test section is 100 mph, what was the speed upstream of the test section where the tunnel measures 20' x 20'? Use conservation of mass and assume incompressible flow. Conservation of mass requires that as the flow moves through a path or a duct the product of the density, velocity and cross sectional area must remain constant; i.e. that $\rho VA = \text{constant}$.
2. A model is being tested in a wind tunnel at a speed of 100 mph.
 - (a) If the flow in the test section is at sea level standard conditions, what is the pressure at the model's stagnation point?
 - (b) The tunnel speed is being measured by a pitot-static tube connected to a U-tube manometer. What is the reading on that manometer in inches of water.
 - (c) At one point on the model a pressure of 2058 psf is measured. What is the local airspeed at that point?

References

- Figure 2.1: Claire Colvin (2021). "TurboJet Engine Illustration." [CC BY 4.0](#).
- Figure 2.2: Claire Colvin (2021). "Illustration of a Turbo-Fan or Fan-Jet Engine." [CC BY 4.0](#).
- Figure 2.3: Claire Colvin (2021). "Turboprop Engine Illustration." [CC BY 4.0](#).
- Figure 2.4: Claire Colvin (2021). "Mass Flows for a Turb-Jet Engine." [CC BY 4.0](#).
- Figure 2.5: Claire Colvin (2021). "Flows Through a Fan-Jet Engine." [CC BY 4.0](#).
- Figure 2.6: James F. Marchman (2004). "The Stream-tube Concept for a Propeller Flow." [CC BY 4.0](#).
- Figure 2.7: Kindred Grey (2021). "A Balloon as a Simple Jet." [CC BY 4.0](#). Adapted from James F. Marchman (2004). [CC BY 4.0](#). Available from https://archive.org/details/2.1_20210804
- Figure 2.8: Claire Colvin (2021). "Momentum Equation Terms for Turbo-Jet." [CC BY 4.0](#).
- Figure 2.9: Kindred Grey (2021). "Momentum Equation Terms for Propeller Flow." [CC BY 4.0](#). Adapted from James F. Marchman (2004). [CC BY 4.0](#). Available from https://archive.org/details/2.9_20210804

<!-- pb_fixme --><!-- pb_fixme -->

This page titled [2: Propulsion](#) is shared under a [CC BY 4.0](#) license and was authored, remixed, and/or curated by [James F. Marchman](#) (Virginia Tech Libraries' Open Education Initiative) via [source content](#) that was edited to the style and standards of the LibreTexts platform.

3: Additional Aerodynamics Tools

Chapter 3. Additional Aerodynamics Tools

Introduction

All of the introductory aerodynamic concepts needed for the aircraft performance material to be covered in the following chapters were presented in Chapter 1. In general, it will be left up to the readers' choice of many excellent texts on the subject of aerodynamics to provide in-depth coverage of the field, including complete derivations of aerodynamic theories and discussions of their usage. The field of aerodynamics is often separated into five or more segments based on the flow characteristics and the assumptions that can or must be made to analyze those flows in detail. These divisions would normally include:

- Incompressible or subsonic aerodynamics
- Transonic aerodynamics
- Supersonic aerodynamics
- Hypersonic aerodynamics
- Boundary layer theory

Other, even more specialized, segments of the aerodynamics field might include such topics as rarefied gas dynamics and magneto-hydrodynamics.

In chapter one we looked at a few basic concepts relevant to the first three topics above with an emphasis on the incompressible flow regime and, hopefully, enough discussion of the assumptions involved for the reader to recognize when he or she is in danger of the need to account for transonic or supersonic flow effects. We looked at some of the basic conclusions that come from an analysis of two and three dimensional flow around airfoils and wings. We learned, for example, that the camber of an airfoil will determine the angle of attack at which the airfoil lift coefficient is zero and that we can temporarily change camber with things like wing warping or its modern equivalent, “morphing”, or, in a more conventional manner with flaps. We might be curious as to how much of a change camber can give in the zero lift angle of attack.

We learned that there is a certain type of spanwise lift distribution on a three dimensional wing that will give “optimum” aerodynamic performance by giving “minimum induced drag” and we found that higher aspect ratio wing planforms also give better performance than wings with low AR.

In this chapter we are going to take a very elementary look at these two fundamental wing and airfoil configuration effects, just enough of a look so we will have at least one or two basic tools that might help us find out something about the effects of wing design on aircraft performance should we need to do so. We will do this, not through the type of thorough analysis that would be found in most good aerodynamic textbooks, but with a couple of somewhat over simplified approaches that are, nonetheless, often useful.

In order to develop the desired “back of the envelope” methods of looking at some basic influences of airfoil and wing shape on aerodynamics and performance we need to first take a quick look at how an aerodynamicist would make a mathematical model of a wing or airfoil. Let's begin by looking at the flow around a lifting airfoil.

3.1 Airfoils (2-D Aerodynamics)

For an airfoil or wing to product lift the flow over its upper surface must move faster than the flow over its lower surface. If this occurs, Bernoulli's equation would tell us that the faster flow over the upper surface will give a lower pressure than the slower flow over the lower surface and this pressure differential will produce lift. If we look at the flow at a point some distance behind the leading edge of an airfoil we will find that we could represent it somewhat as shown in the figure below with a large velocity vector on top of the airfoil and a smaller one on the bottom.

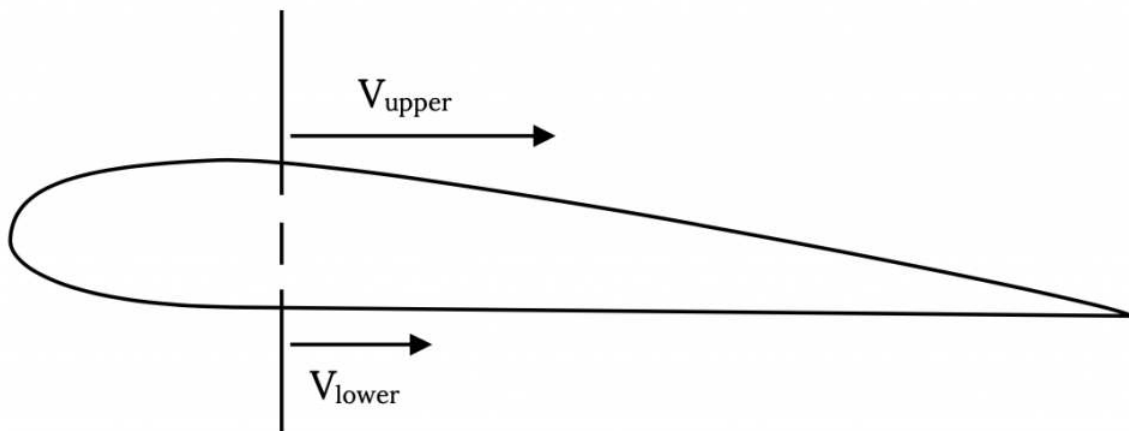

Figure 3.1: Upper/Lower Surface Speed Difference Gives Lift

Another way to represent this same flow would be with a combination of a “uniform” flow and a circular flow, such that the velocities add on top of the wing and subtract on the bottom as shown below.

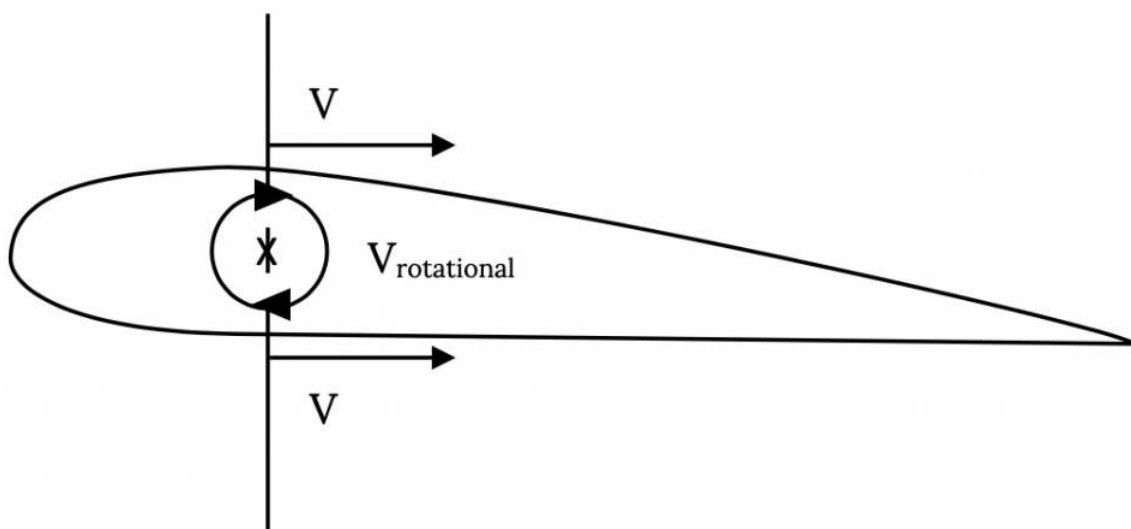

Figure 3.2: Model of Upper/Lower Surface Speed Difference

If these two flows can be said to end up giving the same result, the flow shown in Figure 3.2 can be said to be a way to model the flow around an airfoil. This, in fact, works very well and is the basic idea behind the way an aerodynamicist would model the flow around an airfoil.

We could look at the upper and lower surface velocities at several points along the chord and find that at any point we can model that local flow by a “uniform” flow and a circular type flow as shown in Figure 3.3.

In this model, the “uniform” flows on the upper and lower surface would be exactly the same as the upstream or “freestream” velocity, V_{∞} . The only thing that would change at each position along the chord line would be the circular type flow, which would get more powerful where the speed differential between upper and lower surfaces gets larger and less as it gets smaller.

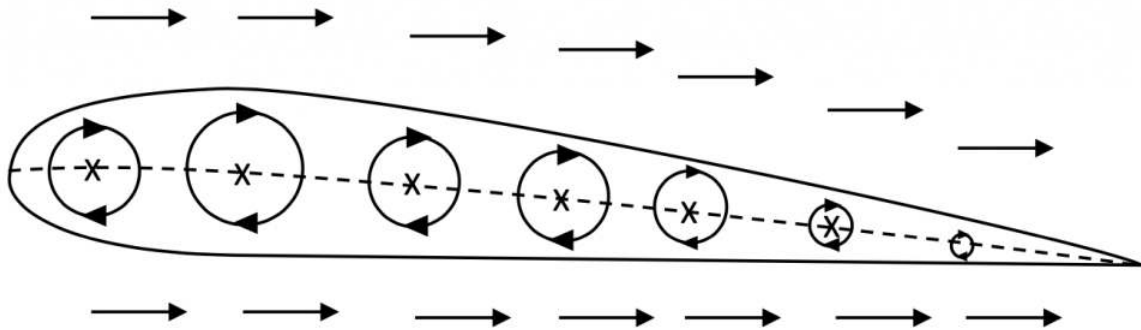

Figure 3.3: Modeling Airfoil Flow With Multiple Vortices

These “circular” flows are known as **vortices** (a single circular flow is a *vortex*) and they are the mathematical equivalent of a little tornado. It turns out that vortices are very important flows in aerodynamics and they occur physically in many places. Of course, there are no vortices in the middle of a wing. Here, we are just using a real physical flow, a vortex, to create a mathematical model that gives us the result that we know actually exists.

These purely circular flows or **vortices** can be described mathematically in terms of their **circulation**. Circulation is technically related to the integration of a velocity around a closed path, a concept that we need not go into here and it is given a symbol gamma [γ or Γ]. The lower case form of the Greek letter, γ , is used when we are combining the effects of a lot of small vortices and the upper case form, Γ , is used either when there is only a single vortex or when we are looking at the combined effect of a lot of small vortices. The circulation, gamma, is essentially the measurement of the rotational speed of the spinning flow in a vortex and it is sometimes called the **strength** of a vortex.

So, the basic concept here is that to get a **lifting flow** (higher speed on the top and lower speed on the bottom) we **combine a vortex flow with a uniform flow**. If we do this and mathematically analyze the result we will find a very important and very simple relationship between the lift produced and the circulation and free stream speed that says:

$$\text{Lift} = \rho V_{\infty} \Gamma$$

The lift is equal to the flow density times the free stream velocity times the circulation. You can find a well done derivation of this basic principle in any good aerodynamics textbook and there you will also find that this concept is so important that it is given a name, the **Kutta-Joukowski Theorem**.

As always, we should look at the units involved with this parameter, the circulation. We should keep in mind that we looked at this concept of a circular type flow as a way to look at lift on a *two-dimensional* slice of a wing, an *airfoil* section. So the lift we are talking about is the lift per unit span of the wing; i.e., the lift per foot or lift per meter. Knowing that, we can see what the units of gamma must be.

$$\text{Lift (pounds per foot)} = \text{density (slugs per foot cubed)} \times \text{velocity (feet per second)} \times \text{gamma}$$

Equating the units in this relationship tells us that the units for gamma must be:

$$(\text{lb/ft}) \div [(\text{sl/ft}^3)(\text{ft/sec})] = (\text{lb ft sec})/\text{sl}$$

and knowing that $F = ma$; i.e., $1 \text{ lb} = 1 \text{ sl ft/sec}^2$, we will find the units for gamma to be

$$\text{units for } \Gamma = \text{ft}^2 / \text{sec} .$$

We may find these units a little strange. They are neither units for speed or acceleration. However, that’s ok, because circulation is not speed or acceleration, it is circulation!

So, what do we do with this? If this were a rigorous aerodynamics course or text we would take a few thousand of these little tornados (vortices) and lay them side by side along the chord or camber line of our airfoil section and do a complicated calculation to see exactly what value of gamma each must have to give the correct lift for an airfoil of a given shape at a given angle of attack

to the free stream flow. We would base this on the shape we wanted our airfoil camber line to have. Finally, we would add up or “integrate” the combined circulations (gammas) for all our little vortices and find the total lift on the airfoil.

We would also look at the “distribution” of those circulations or vortex strengths and find what we could call their “centroid” of vorticity; i.e., the place on the airfoil chord where the total lift could be said to act if all the little vortices could be replaced with a single big vortex. We would call this place the “**center of lift**”.

If we did all this (and, again, we can find this derivation in its full glory in any good aerodynamics text), we will find a few interesting and very useful results that we will list below:

For a “symmetrical” airfoil (no camber)

- **The “center of lift” is at the “quarter chord”; i.e., one fourth of the distance along the chord line from the leading edge.**
- **The two dimensional lift coefficient will be $C_L = 2\pi\alpha$ where α is the angle of attack (angle between the chord line and the free stream velocity vector).**

For a cambered airfoil (non-symmetrical)

- **The “center of lift” is not at the quarter chord and it, in fact, moves as angle of attack changes.**
- **The two dimensional lift coefficient will now be $C_L = 2\pi(\alpha - \alpha_{L0})$, where α_{L0} is called the “zero lift angle of attack” and is a negative angle for a positively cambered airfoil. This means that the lift curve shifts to the left as camber increases and that, at a given angle of attack, the cambered airfoil will produce a larger lift coefficient than the symmetrical airfoil (provided the airfoil is at an angle of attack below that for stall).**

We talked about these same results in Chapter One without saying much about their origins. This shift in lift curve and increase in lift coefficient with increasing camber is the basis for the use of flaps as a temporary way to increase the lift coefficient when a boost in lifting capability is needed such as on landing.

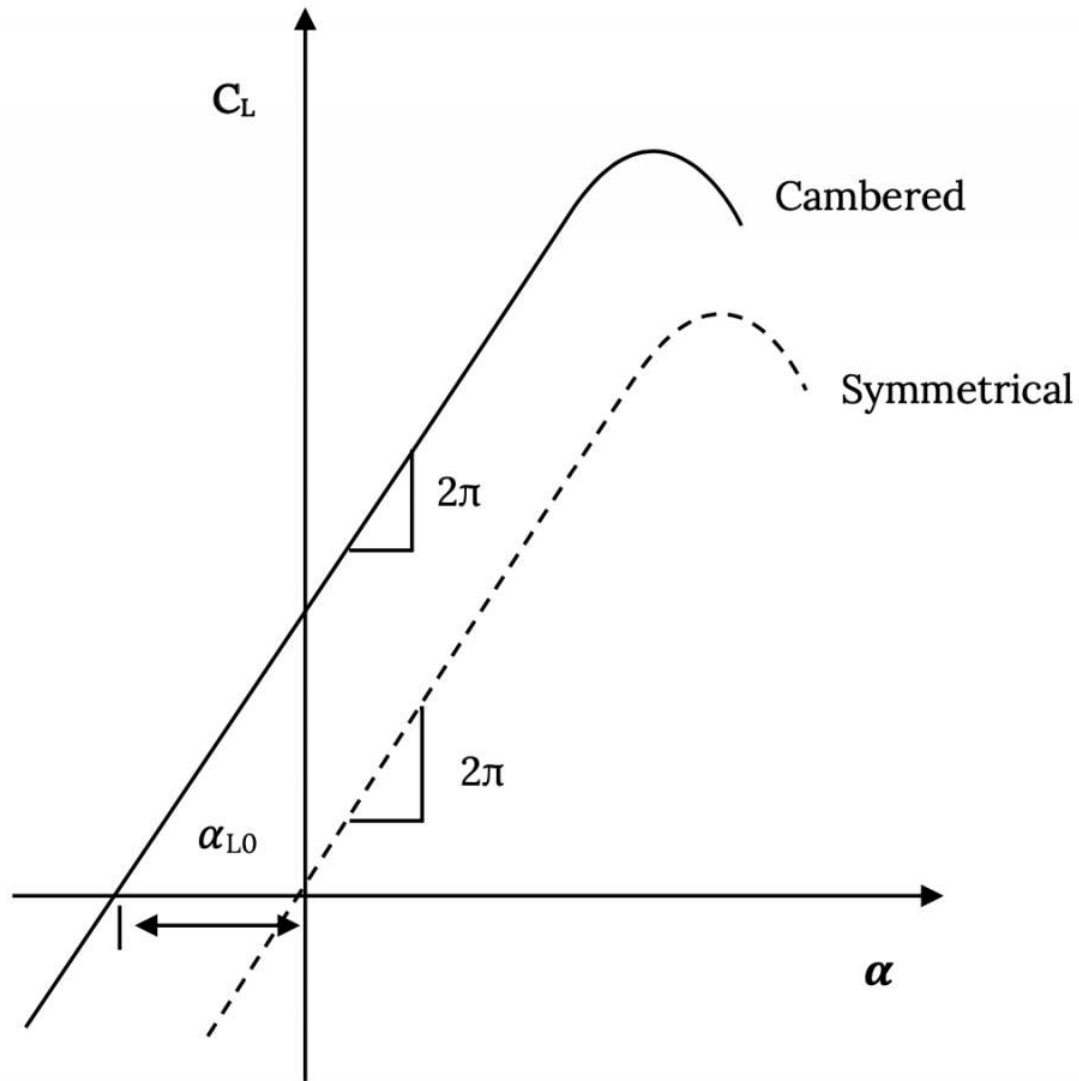

Figure 3.4: Lift Coefficient Curves for Symmetrical and Cambered, 2-D Airfoils

The aerodynamic theory that would predict all this is called “thin airfoil theory” and it does this precisely as described above, by assuming that thousands of tiny vortices are laid side by side in what is called a vortex sheet along the airfoil’s camber line. Knowing the mathematical description of the shape of the desired camber line, the free stream velocity and the angle of attack, and requiring that there be no flow through the camber line and that the flow does not go from one surface to the other around the trailing edge, thin airfoil theory can tell the needed distribution of circulation along the camber line from leading edge to trailing edge to give a simulation of the real flow around the airfoil.

This method can’t predict stall. To do that we would need to consider the effects of shear or viscosity in the flow and this would require us to look at the “boundary layer” or viscous flow region around the actual wing surface. This too, is far beyond the scope of the material we want to investigate in this text.

So, is there a simple way to predict the effects of camber without resorting to thin airfoil theory of some equally messy procedure? It turns out that there is a “back of the envelope” method called “Weissinger’s Approximation”

3.2 Weissinger’s Approximation

Weissinger’s Approximation is based on the symmetrical airfoil results of thin airfoil theory that were listed in a section above. These results say that for a symmetrical airfoil (essentially a flat plate) the lift acts at the quarter chord and the lift coefficient is 2- π times the angle of attack.

We also have the Kutta-Joukowski Theorem which says that lift is equal to the flow density multiplied by the circulation and the freestream velocity.

We can, therefore, combine these two results by saying that we can model the lift on a flat plate by placing a single vortex at the quarter chord of the flat plate (since this is where theory says the net lift acts). All of this gives us the picture shown below.

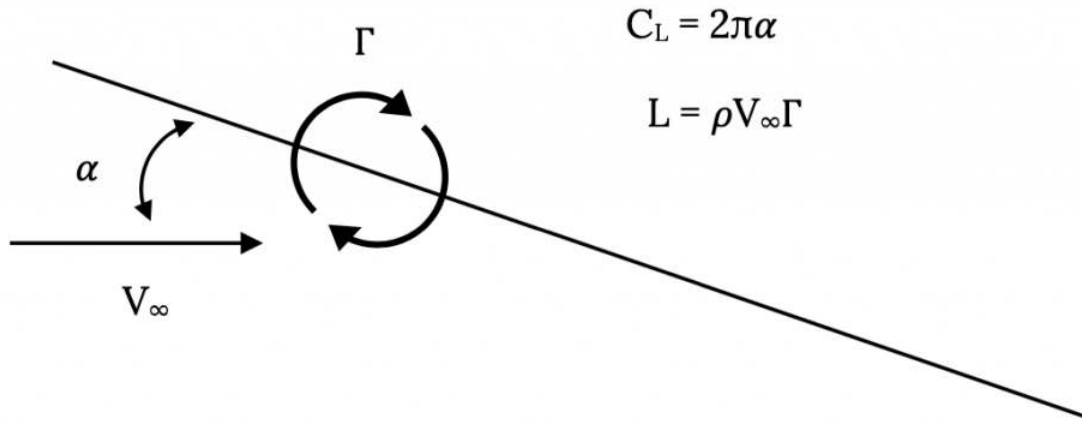

Figure 3.5: Basic Sketch and Equations for Weissinger's Approximation

Basically, we are going to combine these two ideas that describe lift by selecting a place where we would impose a condition of no flow through the flat plate that will equate the lift from the two theoretical results. To do this we need to know something about a vortex that we have not previously introduced. That is, the velocity found in or introduced by a vortex at various distances from its center. Aerodynamic theory would tell us that the circular or tangential velocity in a vortex varies inversely with its radius and is a function of the circulation, Γ , in the vortex. Theoretically, a vortex has an infinite circumferential velocity at its center and this velocity gets smaller as we move further away from the center. This will give

$$V_{\text{vortex}} = \Gamma / (2\pi r)$$

In using this definition of the circumferential velocity in a vortex it is conventional in the field of aerodynamics to define the positive direction for Γ as clockwise. This defies conventional mathematical practice and care has to be taken in being consistent in using the convention.

This is illustrated below.

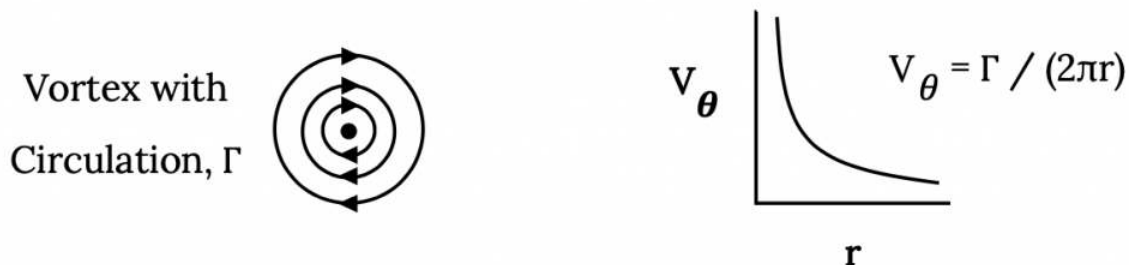

Figure 3.6: Mathematical Model of a Vortex

Going back to our combination of thin airfoil theory results and the Kutta-Joukowski Theorem we have the following task. We want to find some point on the flat plate where the vortex that we have placed at the quarter chord will give just the right amount of velocity to counteract the component of the freestream velocity normal to the plate such that our two looks at lift or lift coefficient

will give the same answers. One theory, the Kutta-Joukowski Theorem tells us that $L = \rho V_\infty \Gamma$ and the other tells us that the lift coefficient $C_L = 2\pi\alpha$.

Realizing that the lift on a two dimensional flat plate is equal to the lift coefficient times the dynamic pressure, multiplied by the length of the plate (a “one dimensional area”), we can write:

$$L = \rho V_\infty \Gamma = (2\pi\alpha)(\frac{1}{2}\rho V_\infty^2)(c),$$

where “c” is the chord (length) of the flat plate.

It is easily seen that what is being sought here is a relationship between the angle of attack and the circulation in the vortex. We are relating the physical reality of lift increasing with angle of attack to the mathematical model that says lift increases with circulation.

$$\Gamma = \pi\alpha V_\infty c.$$

It is this relationship that we use to create our “back of the envelope model” called Weissinger’s Approximation. To see this we need to look again at our flat plate with the vortex at the quarter chord and ask ourselves at what radius from the vortex will the velocity from the vortex be just enough to balance the normal component of the freestream velocity.

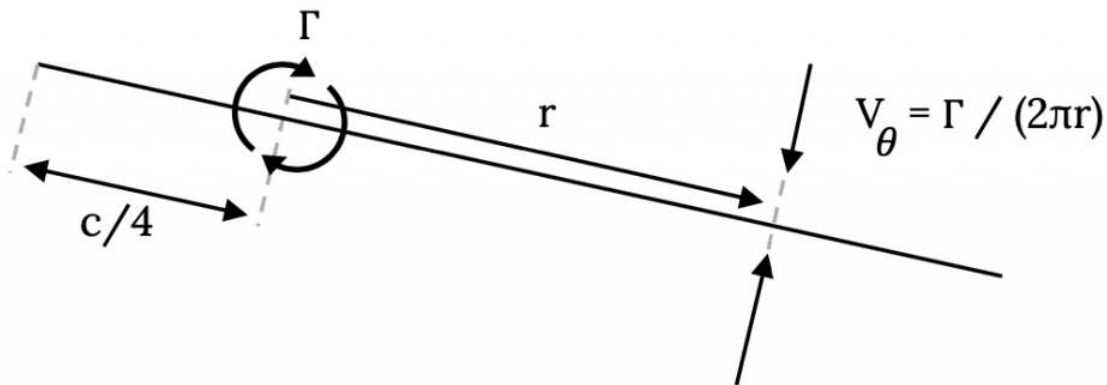

$$V_{\infty n} = V_\infty \sin\alpha \approx V_\infty \alpha \text{ (for small } \alpha \text{)}$$

Figure 3.7: Solution Method for Weissinger’s Approximation

If we look at this illustration and use the last equation above to define the circulation, Γ , in terms of the freestream velocity and the angle of attack and then equate the velocity from the vortex and the normal component of the freestream velocity, we find

$$V_\theta = \Gamma / (2\pi r) = (\pi\alpha V_\infty c) / (2\pi r) = V_{\infty n} = V_\infty \sin(\alpha) \approx V_\infty \alpha$$

or,

$$(\alpha V_\infty c) / (2r) = V_\infty \alpha, \text{ for small angles of attack.}$$

The final outcome of this is that the distance, r , at which we must solve for “no flow through the flat plate” to make the two theoretical models compatible is:

$$r = c/2.$$

We must solve for no flow through the plate at a point three-fourths the way back (at the three-quarter chord point) to make this “approximation” work. We call this point the “control point”.

OK, so what’s the big deal? We’ve found a new way to get a result we already know and it is only for a flat plate! How can this “approximation” tell us anything we don’t already know?

The reason this is so useful is that we can “build” approximate models of cambered or flapped airfoils from flat plates. Consider the simple case of a symmetrical airfoil with a plain flap taking up the final 20% of its chord. We can model this as two sequential flat plates with one flat plate of length of 80% of the airfoil chord and the other 20% of the chord and we can deflect the “flap” and see what it does to the lift coefficient. The way this is done is illustrated in the figure below:

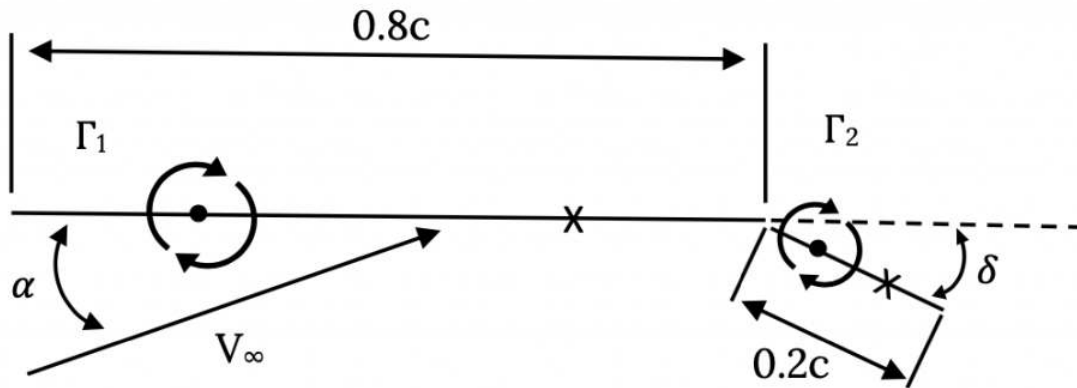

Figure 3.8: Use of Two Panel Weissinger Method for Flapped Airfoil

In the above case we will end up with two equations and two unknowns, the two values of circulation. To get these two equations we look at the flows normal to the two plates at their respective “control points” that have been placed at the $\frac{3}{4}$ chord points on each plate or panel. Lets look first at the control point on the first panel.

There will be three velocities that must be accounted for at this point; the component of the freestream velocity normal to the panel, the velocity induced by the vortex on the first panel, and the velocity induced by the vortex on the second panel. We can see in the figure below that the freestream velocity is directed upward while the velocities from the two vortices will be in opposite directions (that due to the first vortex is “down” and the velocity from the second vortex is “up”, if we assume the vortices are “positive” or clockwise). We can account for these directions by either mental bookkeeping and noting that they all must add to zero, or by conscientiously accounting for signs on the vector quantities, noting that the radii (r_{11} and r_{21}) have signs related to their direction.

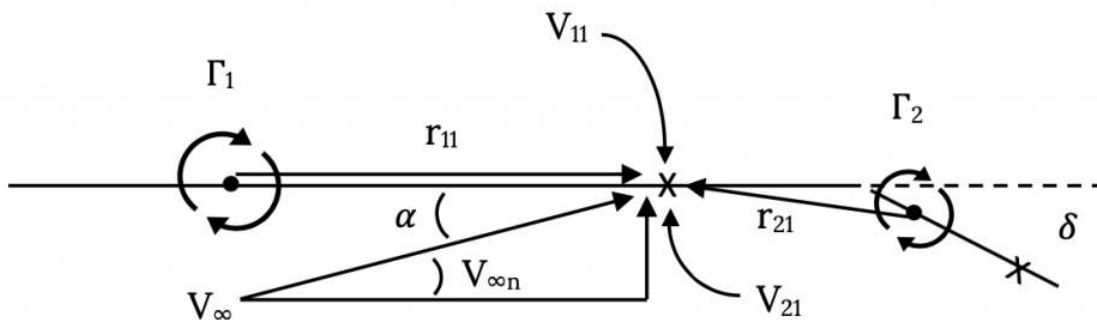

Figure 3.9: Solution Method at the First Control Point

Note that the velocity induced at control point 1 by the vortex on panel 2 is not exactly perpendicular to panel 1. We could be very precise and use a little trigonometry to figure out the exact angle and account for it to find the true normal component or we could just assume it is close enough to normal to ignore the angle. Since this is an approximate method anyway, except in the case of very large angles (say ten degrees or more) we will usually ignore the error. Doing this, we can write an equation adding the two vortex components of velocity and equating their sum to the free stream component.

$$\mathbf{V}_{11} + \mathbf{V}_{21} = \mathbf{V}_{\infty n1} = V_{\infty} \sin(\alpha_1) \approx V_{\infty} \alpha_1$$

where

$$V_{11} = \Gamma_1 / (2\pi r_{11})$$

$$V_{21} = \Gamma / (2\pi r_{21})$$

and where

$$r_{11} = 0.4c$$

$$r_{21} \approx -0.25c$$

Now, we would do exactly the same thing at the control point on the second panel.

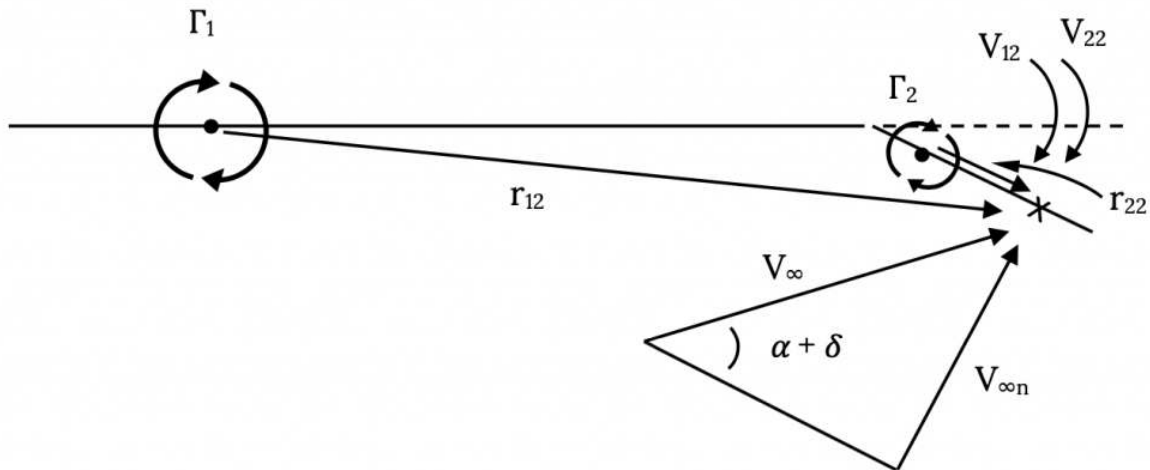

Figure 3.10: Solution Method at Second Control Point

Here our equation will be similar to the one at the control point on panel one except that we will probably have to account for the fact that the flap deflection angle will probably be too large to simply ignore in finding the normal component of the freestream velocity.

$$V_{12} + V_{22} = V_{\infty n2} = V_\infty \sin(\alpha_2) = V_\infty \sin(\alpha + \delta)$$

where

δ = flap deflection angle

$$V_{12} = \Gamma_1 / (2\pi r_{12})$$

$$V_{22} = \Gamma_2 / (2\pi r_{22})$$

$$r_{12} \approx 0.75c$$

$$r_{22} = 0.1c$$

We would then simultaneously solve these two equations, each having two unknowns (Γ_1 and Γ_2) for those unknown values. We would then use those two values of circulation to find the total lift and lift coefficient where the lift would simply be found from the Kutta-Joukowski Theorem, summing the lifts on each panel.

$$L = \Sigma \rho V_\infty \Gamma = \rho V_\infty [\Gamma_1 + \Gamma_2]$$

and the lift coefficient would be

$$C_L = L / (\frac{1}{2} \rho V_\infty^2 c) = 2[\Gamma_1 + \Gamma_2] / (V_\infty c)$$

Exercise:

Solve the problem above for a freestream speed of 100 mph, a flap deflection of 20 degrees, and a 5 foot wing chord at sea level conditions at an angle of attack of 5 degrees. How does this lift coefficient compare with that for a symmetrical airfoil at the same angle of attack?

Note that in the above approximate solution for a flapped, symmetrical airfoil we have a very crude “lift distribution” over the airfoil chord, that is, we know the way lift can be divided to act at the two locations above. If we solved this for several different angles of attack we would find that the relative values of the two vortex strengths (circulations) would change. If we looked closely at this we would find that, unlike for the symmetrical airfoil where the lift can always be said to act at the airfoil quarter chord, for the cambered airfoil the point where the lift will act (*center of lift* or *center of pressure*) will move with angle of attack and will be a function of camber. If we wanted to find this more precisely we could use more panels and more vortices and control points (along with more equations). For the above example it might be natural to simply divide the airfoil into five panels of equal lengths, each 20% of the original chord, looking something like the sketch below.

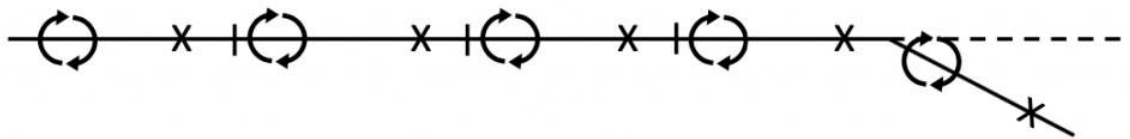

Figure 3.11: Five Panel Weissinger Sketch for Flapped, Symmetrical Airfoil

And, it is not too hard to imagine extending this method to a truly cambered airfoil as shown in Figure 3.12.

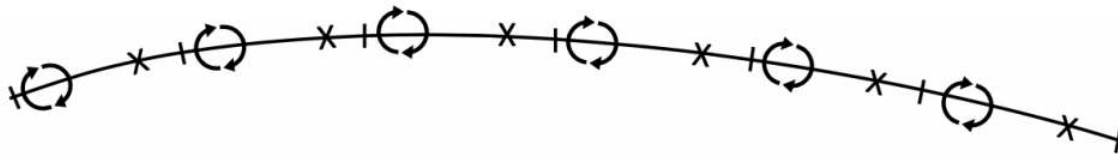

Figure 3.12: Weissinger Method for Cambered Airfoil

This simple approximation based on the results of flat plate aerodynamic behavior has, in this way, been stretched into a true “numerical solution” for an airfoil of any camber shape with as many panels as we wish to use. We can use it to find the total lift or lift coefficient for an airfoil with any camber shape and also to find the way lift is distributed over the airfoil chord.

Another thing we can find from this is the “pitching moment” of the airfoil, its tendency to rotate nose up or nose down about any desired reference point on the chord. The pitching moment is just found by taking each “lift” force found from the individual circulations and multiplying it by the distance or “moment arm” between that vortex and the desired reference point. If, for example, we want to use the leading edge of the wing as our moment reference (a common choice in theoretical or numerical calculations) we only need to take each value of γ times the distance from the airfoil leading edge and that vortex and sum these to get the total pitching moment about the leading edge.

For the symmetrical airfoil (flat plate) where the center of lift is always at the quarter chord, this pitching moment around the leading edge will always be the lift multiplied by the quarter chord distance. The pitching moment coefficient for this case would be the lift multiplied by the quarter chord distance, divided by the dynamic pressure times the square of the chord. Do a quick calculation to see what this would be?

3.3 Pitching Moment

While we are talking about finding the pitching moment let’s take a look at some special cases. Pitching moment can be calculated or measured about any point we wish to use. Often in analytical or numerical calculations it is convenient to find the pitching moment around the wing leading edge. On the other hand, in wind tunnel testing it might be more convenient to measure the moment at some point between 20% and 50% back from the leading edge because of the ease of attaching the force and moment balance system there.

In Chapter One we mentioned two significant locations where the pitching moment or its coefficient has special meanings. These were the *center of pressure* (center of lift) and the *aerodynamic center*; points where the moment coefficient is zero or where it

remains constant as the lift coefficient and angle of attack change. According to thin airfoil theory these are coincident at the quarter chord for a symmetrical airfoil but for the cambered airfoil, the center of pressure will usually move as angle of attack changes while the aerodynamic center remains at the quarter chord. We can verify that this theoretical result is a pretty good match for reality by looking at the aerodynamic data plots presented in Appendix A (discussed earlier in Chapter One). Often these plots present two graphs for pitching moment coefficient with the first one (on the left in most figures) a plot of $C_{Mc/4}$ (the moment coefficient at the quarter chord) and the other plot (usually on the right) of C_{MAC} (moment coefficient at the aerodynamic center). In the plots in Appendix A for cambered airfoils it can be seen that $C_{Mc/4}$ is non-zero in value and changes with angle of attack while C_{MAC} is relatively constant prior to the onset of stall. In the plots of symmetrical airfoil data both of these quantities are zero (or near zero) in value and constant prior to stall. In stall, the lift or pressure distribution over the airfoil is changing drastically as the flow begins to separate over progressively larger portions of the airfoil and the approximations of thin airfoil theory are far from valid.

As noted in the previous section, the pitching moment and moment coefficient can be calculated along with the lift when using the Weissinger Approximation. To find the location of the center of pressure we need only use the definition of that point as being where the moment is zero to find its location. Based on the illustration below, we can assume the center of pressure is located at some point x_{cp} and sum the moments about that unknown point due to the various circulation induced lift forces to equal zero.

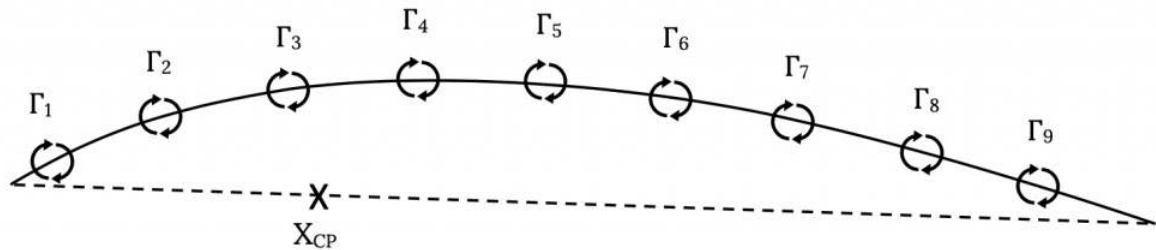

Figure 3.13: Finding the Center of Pressure

$$\rho V_{\infty} [\Gamma_1(x_1 - x_{cp}) + \Gamma_2(x_2 - x_{cp}) + \dots + \Gamma_n(x_n - x_{cp})] = 0$$

In this equation x_1, x_2, \dots, x_n are the locations along the chord of the various vortices (each at the quarter chord of its panel) and x_{cp} is the unknown location of the center of pressure. This is solved for x_{cp} , the location of the center of pressure. Note that for a symmetrical airfoil (flat plate) this position should not change with angle of attack while for a cambered airfoil x_{cp} will be different for every angle of attack.

In a similar, but slightly more complicated fashion, we could find the location of the aerodynamic center from Weissinger Approximation lift results. This would involve finding the point where $dC_M/dC_L = 0$. We will leave this calculation for a text or course in aerodynamics.

3.4 Wings (3-D Aerodynamics)

As was pointed out in Chapter One, the main difference between two-dimensional flow around an airfoil and three-dimensional flow around a wing is the flow around the wing tip from the bottom to the top of the wing. This results in several things:

- An outward flow along the bottom of the wing near the tip.
- An inward flow along the top of the wing near the tip.
- A trailing vortex system.
- A “downwash” on the wing caused by the trailing vortex system.
- An “induced drag” caused by the downwash.

This vortex flow off of each wing tip is a very real flow that can be seen in the wind tunnel with either smoke or by simply sticking a string in the flow behind the wing tip. It can also be seen on airplanes in flight when atmospheric conditions are right. If there is sufficient moisture in the air in the form of high relative humidity or due to water vapor in the jet engine exhaust being pulled into the trailing vortices, the low pressure in the vortex core will cause the water vapor to condense, making it visible as a pair of “white tornados” trailing behind each wing tip. It is interesting to watch these when they are visible from high flying jets and to see just

how long they persist. They can exist for many miles behind the generating aircraft, illustrating both the amount of energy in the vortices and the danger to other aircraft that might encounter them.

These “trailing vortices” are the key factor in trying to create any kind of mathematical model of the 3-D flow around and behind a real wing. In essence, this is done by bending the vortices that were used to model the flow over an airfoil at a 90 degree angle and allowing them to trail behind the wing. And, since we know that the lift on the wing varies along its span and doesn’t just stay the same all the way out to the wing tip, we allow vortices to turn right or left and come off the wing all along its span. This produces what is called a “horseshoe vortex system”.

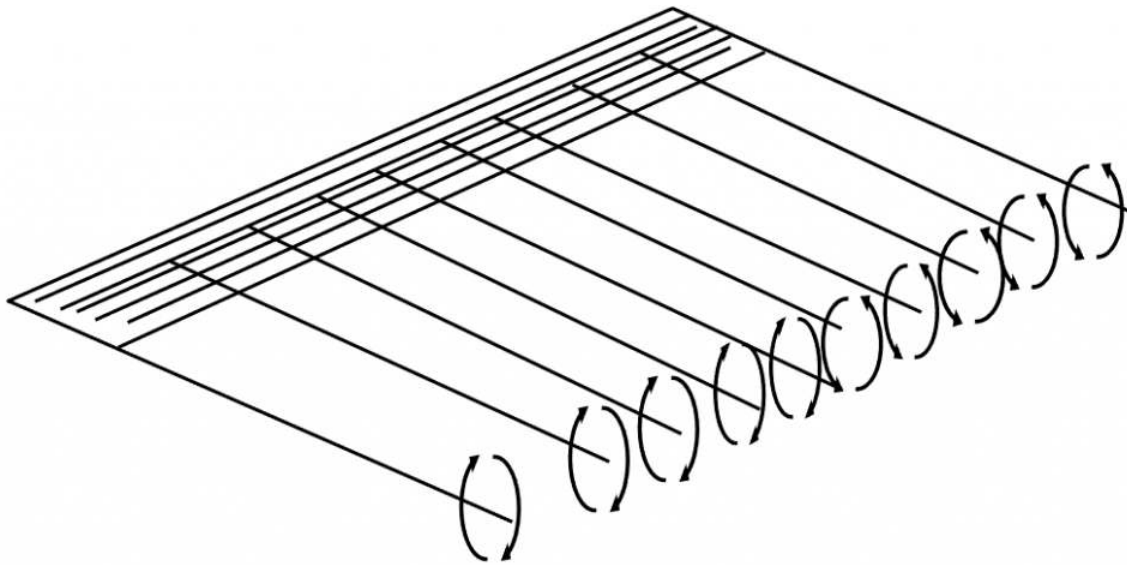

Figure 3.14: Horseshoe Vortex System

While this theoretical derivation is beyond the intended scope of this material, its essence is found in the following facts or assumptions:

- The total circulation on the wing is assumed to vary along the span and to go to zero at the wing tips.
- The “trailing vortices” induce a downward flow or “downwash” that creates a small but significant downward velocity on the wing itself. (Actually, this is a way to account for the downward momentum of the flow that results from the lift force. This could also be found from the momentum equation if we had sufficient information.)
- In the same way that the interaction of the freestream velocity, V_∞ , with the vortex circulations on the wing results in lift (Kutta-Joukowski Theorem), the interaction of this “downwash” velocity with the vortex circulations causes a drag. We call this the “induced drag”.

Using this horseshoe vortex model and assuming that all the vortices on the wing are bundled into a single, rope-like, core at the quarter chord of the wing and also assuming that the wing quarter chord is unswept, a method referred to as “*lifting line theory*” can be used to find the lift variation along the span and the induced drag for any unswept wing of moderate to high aspect ratio. Any good text on aerodynamics will have a full development of this approach to 3-D aerodynamics and will present its results.

One of the results of the use of lifting line theory will be an “optimum” case, that is, a spanwise lift distribution on the wing where the induced drag is a minimum. This turns out to be a solution where the spanwise distribution of circulation over the wing is elliptical in shape and mathematical form. This special solution will give the equation for induced drag coefficient that we have already cited in Chapter One,

$$C_{Di} = C_L^2 / (\pi AR)$$

where “AR” is the aspect ratio,

$$AR = b^2/S = b/c_{avg}.$$

The more general (non-optimum) form of this equation for induced drag coefficient includes another term, “e”, known as Oswald’s efficiency factor, that accounts for non-elliptical spanwise variations of circulation.

$$C_{Di} = C_L^2 / (\pi AR e)$$

This Oswald’s efficiency factor can be calculated from lifting line theory in the form of a Fourier series.

While it is not the purpose of this text to go into much detail examining lifting line theory, I would like to briefly look at what it says about lift for the special, minimum drag, case of the elliptical lift distribution because we often use this special case to take a first look at the influences of wing design on aerodynamics and performance. Without deriving them, we will simply look at some of the most important results of lifting line theory related to lift:

$$L = (\pi/4)\rho V_\infty b \Gamma_{center}$$

where

$$b = \text{wing span}$$

$$\Gamma_{center} = \text{the value of the circulation at the center of the wing span}$$

and

$$\Gamma_{center} = (2C_L V_\infty S) / (\pi b)$$

Note that this makes the lift coefficient a function of the aspect ratio:

$$C_L = L / (\frac{1}{2}\rho V_\infty^2 S) = (\pi b \Gamma_{center}) / (2 V_\infty S) = (\pi AR \Gamma_{center}) / (2b V_\infty)$$

This says that for any given angle of attack (or value of circulation since Γ_{center} must increase with angle of attack) a higher aspect ratio wing design will give a higher lift coefficient than a low AR wing.

If we plot lift coefficient versus angle of attack for two wings of different aspect ratio we would find that the “slope” of the lift curve would decrease with decreasing aspect ratio. The maximum value of the slope is 2-pi, the two dimensional airfoil value, equivalent to an infinite aspect ratio wing.

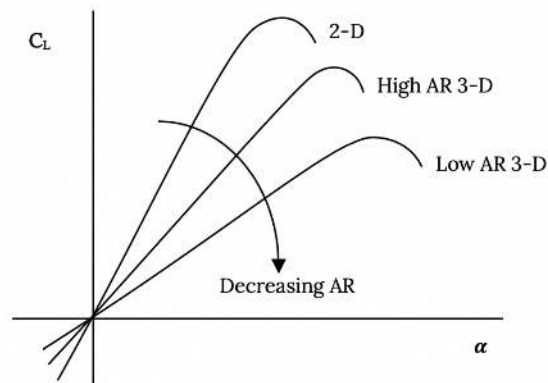

Figure 3.15: 3-D Aspect Ratio Effects on Lift Curve Slope

Another way to look at this same effect is to look at the angle of attack at which two wings of different aspect ratios must be flown to get the same value of lift coefficient:

$$\alpha_2 = \alpha_1 + (C_L/\pi) [(1/AR_2) - (1/AR_1)]$$

The above relationships give us valuable tools for examining the effects of design variables like wing aspect ratio on the aerodynamics and performance of an aircraft. Should we wish to use a moderate aspect ratio wing instead of a high aspect ratio design for, say, structural reasons or for improved roll dynamics, we can see what penalty we will pay. Often the penalty may not be as great as we might at first believe based on our basic knowledge that high aspect ratio is usually desirable.

These equations are, as mentioned earlier, for the ideal case, the elliptical lift distribution or minimum induced drag case. Nonetheless, they can give us a pretty good idea of how things like changes in aspect ratio will influence the performance of any three-dimensional wing.

One final thing I would like to mention in this chapter relates to the assumptions mentioned earlier for lifting line theory. It was noted that this theory assumes that the quarter chord of the wing is unswept. Another assumption inherent in the use lifting line theory that was not mentioned is that the theory is not very good for low aspect ratio wings. Even with these two important limitations, lifting line theory gives us some important insights into 3-D aerodynamics. But, what would we do if we are looking at a wing with sweep or low aspect ratio?

For swept wings, wings with low aspect ratio, or any other wing beyond the bounds of the assumptions of lifting line theory, the usual approach is to go to some variation of what is called “vortex lattice” theory. The wing (or even the entire airplane) is divided into panels and a single “horseshoe” vortex is placed at the quarter chord of each panel in what is essentially a three-dimensional version of Weissinger’s Approximation. If the wing is broken into N panels, there are N horseshoe vortices and these must be solved by setting up N equations. The equations are solved for the condition of no flow through the panels (the same idea as with Weissinger’s Approximation) at the center span of the three-quarter chord of the panel. This solution is three times as complex as the 2-D Weissinger method because each horseshoe vortex has three segments (one spanning the panel’s quarter chord and the other two acting as “trailing vortices” from the first vortex at the panel’s edges). Just as in the 2-D method, the equations solved at the “control points” had to account for all the velocities induced by all the vortices on the airfoil as well as the freestream velocity, in the 3-D vortex lattice approach the equation at each panel’s control point must account for the velocities induced by all three vortex segments from all N panels as well as for the freestream velocity.

Vortex lattice methods can be intimidating at first; however, like the Weissinger Approximation in 2-D, they merely use N equations to solve for N unknowns where the unknown is the strength of the horseshoe vortex on each 3-D panel. Everything else boils down to modeling the geometry of the 3-D wing. The result will be the 3-D velocity vector parallel to each panel control point and these can be used to find the pressures and forces and moments all around the wing.

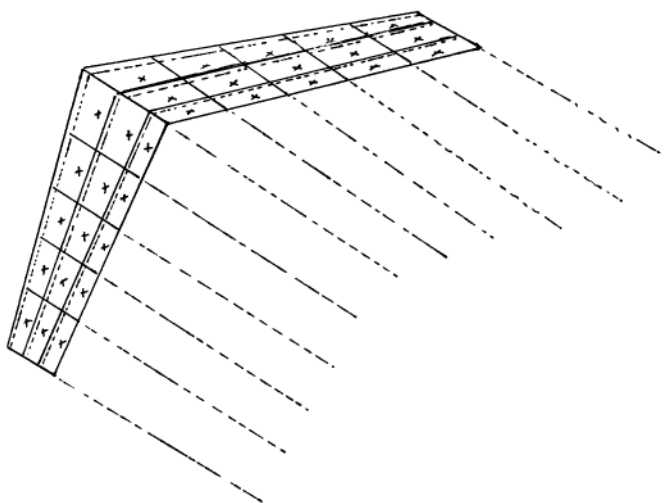

Figure 3.16: Sketch of Vortex Lattice Paneling Method

3.5 Vortex Aerodynamics: Winglets

We will look at one final subject in this chapter, that of “vortex aerodynamics”. As we have already seen, vortices play a major role in the way we mathematically model airfoil and wing aerodynamics. And, as we have seen in the case of three dimensional flows around wing tips, vortices actually play a very real role in creating things like lift and drag and the math models we construct to explain aerodynamics also do an excellent job of modeling these real vortices and their effects.

There are many situations in addition to the wing tip vortices where these tornado-like flows exist in “real life” and play a major role in creating forces and moments on airplanes and wings. One of the jobs of the aerodynamicist is to correctly model these

vortices and their effects and another job may be to determine if there are ways to use these swirling flows to our advantage in ways that will improve an airplane's aerodynamics and flight performance.

We will look at two very important and interesting cases where vortex aerodynamics plays important roles. These are in the use of "winglets" and "leading edge extensions" (sometimes known as "strakes" or "wing gloves").

The winglet is, by now, a fairly well known addition to the wing tips of many airplanes but its purpose is widely misunderstood. For many, many years engineers and scientists tried many approaches that might reduce the strength or effects of wing tip vortices or that would eliminate them altogether. Unfortunately, the laws of Physics are hard to overcome, and this rotational energy that we quantify as "circulation" has to go somewhere at the wingtip and there is really no way to eliminate it in flight other than to let it slowly dissipate as a trailing vortex pair somewhere in the atmosphere far downstream of the aircraft. We can put big plates on the wingtip or create interesting wingtip shapes in attempts to eliminate or hasten the dissipation of the trailing vortices but the usual effect is simply to create a slightly different circular or tangential velocity distribution within the vortex itself, a pattern that may or may not make the vortices less dangerous to trailing aircraft and may or may not result in any reduction in the wing's induced drag. Usually the effects of such "fixes" are greater in their inventor's imagination than in real life.

The winglet, more properly known as the Whitcomb winglet after their inventor, Richard Whitcomb of NASA-Langley, is, contrary to conventional wisdom, not designed to eliminate the wingtip vortices. Rather than try to eliminate something that can't be eliminated without eliminating the wing's lift, Whitcomb decided to use the trailing vortices to create a positive effect. In a conversation with the author, Mr. Whitcomb explained that he saw the winglets as working much like the keel on a sailboat that is sailing or "tacking" into the wind. A sailboat keel is a kind of wing on the bottom of the boat, and when a sailboat is sailing into the wind, the forward force is not coming from the sail at all. Instead, the sail is creating a sideward force that pushes the keel through the water in such a way as to create a forward directed force. The forward force pushing a sailboat into the wind is coming from a small wing in the water rather than from the large wing we call a sail.

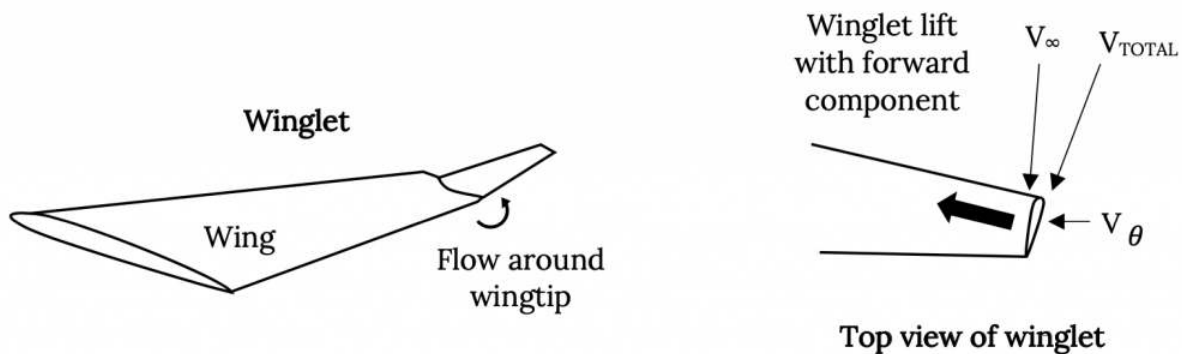

Figure 3.17: Winglet Operation

In creating the winglet, Richard Whitcomb reasoned that if the large wing on a sailboat could create a flow over a smaller wing (the keel) that would produce a thrust, there ought to be a way to take the flow created by a large wing on an airplane (the tip vortex) and use it to create a thrust on a smaller wing. That smaller wing ended up being the winglet. The Whitcomb winglet is placed at what would appear to be a negative angle of attack on the wingtip such that the combination of the freestream velocity and the wingtip vortex flow velocities creates a "lift" on the winglet that is actually pointed forward, giving a thrust. And it turns out that this thrust is significant enough to improve the lift-to-drag ratios on a wing by fifteen to twenty percent. This can result in very significant improvements in airplane flight performance and economics.

3.6 Vortex Aerodynamics: Leading Edge Vortex

The second type of real vortex that we want to examine very briefly is the "leading edge vortex". Such a vortex forms when a wing is swept to angles of about 50 degrees or more. These vortices, illustrated in figure 3.18 below, result from a combination of a three-dimensional, spanwise flow on the wing and from the normal flow around the leading edge of the wing. This combined flow actually separates from the wing surface at the leading edge but, due to the rotational flow in the vortex, reattaches to the wing

surface in such a way that the wing does not stall at the usual fifteen to twenty degree angle of attack but has attached flow and lift up to much larger angles of attack.

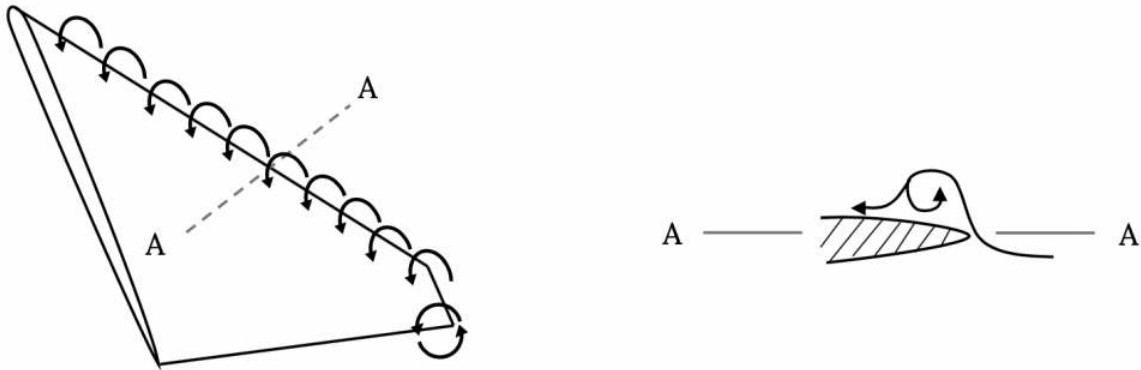

Figure 3.18: Leading Edge Vortex

Wings are usually swept to delay the onset of the transonic drag rise near Mach One and to reduce the magnitude of that drag rise. On the other hand, swept wings produce less conventional lift at a given angle of attack than an unswept wing, in much the same manner as lower aspect ratio wings give less lift at a given angle of attack than high aspect ratio wings. The effect of the leading edge vortex is two-fold. First, by keeping the flow attached to much higher than normal angles of attack, they enable the wing to produce lift at these higher than normal angles of attack. Added to this increased angle of attack advantage is an extra lift, called “vortex lift” that is created by the very low pressure at the vortex core. Unfortunately, this low pressure in the vortex also adds some drag, but the net effect can be very useful in allowing airplanes that need highly swept wings to operate efficiently at transonic and supersonic speeds to still get the lift they need at lower subsonic speeds. They also can allow military fighter airplanes to “fly” at very unusual attitudes (angles of attack) that can be very useful in air-to-air combat.

Sometimes we want to create this same capability on wings that aren’t swept that much. This can be done by adding highly swept leading edge extensions or strakes. These strakes create their own leading edge vortices which continue over the wing behind them, giving many of the benefits mentioned above and allowing airplanes with relatively low wing sweep to fly at much higher than normal angles of attack when needed. One airplane that makes good use of this effect is the Navy’s F-18. Its very long and highly swept strakes enable it to operate at the high angles of attack and low speeds needed for landing and takeoff on aircraft carriers while also giving it very useful high angle of attack maneuverability that is very useful in fighter combat.



Figure 3.19: Vortex Flows on an F-18 (NASA Photo)

As was mentioned at the beginning of this chapter, the coverage in the chapter is not really needed to be able to understand or work with the material on aircraft performance that will follow. It has been included simply to fill in some of the blanks that might have been left open in Chapter One. On the other hand, it can be used to enhance the following aircraft performance coverage and to better relate it to some of the basic concepts in aerodynamics.

Homework 3

1. The Airbus 380-100 is designed to cruise at 35,000 ft at a Mach number of 0.85. Its weight in cruise is approximately one million pounds. It has a wing area of 9100 ft² and a wing span of 262 ft. Assuming that lift equals weight and thrust equals drag and that in cruise at this altitude 50,000 pounds of thrust is needed, find:

- The flight speed in miles per hour and in knots
- The lift coefficient
- The drag coefficient
- Its Reynolds number based on mean chord

2. If an airplane is taking off by simply accelerating down the runway until it has sufficient speed for its lift to equal its weight and its wing is at a five-degree angle of attack, what speeds are required for takeoff at sea level and at 5000 feet altitude assuming that its wing has a lift curve slope ($dC_L/d\alpha$) of 0.08 per degree and a zero-lift angle of attack (α_{L0}) of minus one degree? Also find the indicated airspeed at both altitudes. Assume the airplane weighs 11,250 pounds and has a wing area of 150 ft².

Note: Normally most aircraft would accelerate at a low value of lift coefficient and then “rotate” to increase their angle of attack to a value that will give lift + weight at the defined take-off speed. This would allow take-off in a shorter distance than the method above. We will look at this in detail later in the course.

References

Figure 3.1: Kindred Grey (2021). “Upper and Lower Surface Speed Difference Gives Lift.” [CC BY 4.0](#). Adapted from James F. Marchman (2004). [CC BY 4.0](https://archive.org/details/3.1_20210804). Available from https://archive.org/details/3.1_20210804

Figure 3.2: Kindred Grey (2021). “Model of Upper and Lower Surface Speed Difference.” [CC BY 4.0](#). Adapted from James F. Marchman (2004). [CC BY 4.0](https://archive.org/details/3.2_20210804). Available from https://archive.org/details/3.2_20210804

Figure 3.3: Kindred Grey (2021). “Modeling Airfoil Flow With Multiple Vortices .” [CC BY 4.0](#). Adapted from James F. Marchman (2004). [CC BY 4.0](#). Available from https://archive.org/details/3.3_20210804

Figure 3.4: Kindred Grey (2021). “Lift Coefficient Curves for Symmetrical and Cambered, 2-D Airfoils.” [CC BY 4.0](#). Adapted from James F. Marchman (2004). [CC BY 4.0](#). Available from https://archive.org/details/3.4_20210804

Figure 3.5: Kindred Grey (2021). “Basic Sketch and Equations for Weissinger’s Approximation.” [CC BY 4.0](#). Adapted from James F. Marchman (2004). [CC BY 4.0](#). Available from https://archive.org/details/3.5_20210804

Figure 3.6: Kindred Grey (2021). “Mathematical Model of a Vortex.” [CC BY 4.0](#). Adapted from James F. Marchman (2004). [CC BY 4.0](#). Available from https://archive.org/details/3.6_20210804

Figure 3.7: Kindred Grey (2021). “Solution Method fo Weissinger’s Approximation.” [CC BY 4.0](#). Adapted from James F. Marchman (2004). [CC BY 4.0](#). Available from https://archive.org/details/3.7_20210804

Figure 3.8: Kindred Grey (2021). “Use of Two Panel Weissinger Method for Flapped Airfoil.” [CC BY 4.0](#). Adapted from James F. Marchman (2004). [CC BY 4.0](#). Available from https://archive.org/details/3.8_20210804

Figure 3.9: Kindred Grey (2021). “Solution Method at the First Control Point.” [CC BY 4.0](#). Adapted from James F. Marchman (2004). [CC BY 4.0](#). Available from https://archive.org/details/3.9_20210804

Figure 3.10: Kindred Grey (2021). “Solution Method at Second Control Point.” [CC BY 4.0](#). Adapted from James F. Marchman (2004). [CC BY 4.0](#). Available from https://archive.org/details/3.10_20210804

Figure 3.11: Kindred Grey (2021). “Five Panel Weissinger Sketch for Flapped, Symmetrical Airfoil.” [CC BY 4.0](#). Adapted from James F. Marchman (2004). [CC BY 4.0](#). Available from https://archive.org/details/3.11_20210804

Figure 3.12: Kindred Grey (2021). “Weissinger Method for Cambered Airfoil.” [CC BY 4.0](#). Adapted from James F. Marchman (2004). [CC BY 4.0](#). Available from https://archive.org/details/3.12_20210804

Figure 3.13: Kindred Grey (2021). “Finding the Center of Pressure.” [CC BY 4.0](#). Adapted from James F. Marchman (2004). [CC BY 4.0](#). Available from https://archive.org/details/3.13_20210804

Figure 3.14: Kindred Grey (2021). “Horseshoe Vortex System.” [CC BY 4.0](#). Adapted from James F. Marchman (2004). [CC BY 4.0](#). Available from https://archive.org/details/3.14_20210804

Figure 3.15: Kindred Grey (2021). “3-D Aspect Ratio Effects on Lift Curve Slope.” [CC BY 4.0](#). Adapted from James F. Marchman (2004). [CC BY 4.0](#). Available from https://archive.org/details/3.15_20210804

Figure 3.16: James F. Marchman (2004). “Sketch of Vortex Lattice Paneling Method.” [CC BY 4.0](#).

Figure 3.17: Kindred Grey (2021). “Winglet Operation (a) Winglet.” [CC BY 4.0](#). Adapted from James F. Marchman (2004). [CC BY 4.0](#). Available from https://archive.org/details/3.17_20210804

Figure 3.18: Kindred Grey (2021). “Leading Edge Vortex.” [CC BY 4.0](#). Adapted from James F. Marchman (2004). [CC BY 4.0](#). Available from https://archive.org/details/3.18_20210804

Figure 3.19: James F. Marchman (2004). “Vortex Flows on an F-18 (NASA Photo).” [CC BY 4.0](#).

<!-- pb_fixme --><!-- pb_fixme -->

This page titled [3: Additional Aerodynamics Tools](#) is shared under a [CC BY 4.0](#) license and was authored, remixed, and/or curated by [James F. Marchman](#) (Virginia Tech Libraries' Open Education Initiative) via [source content](#) that was edited to the style and standards of the LibreTexts platform.

4: Performance in Straight and Level Flight

Introduction

Now that we have examined the origins of the forces which act on an aircraft in the atmosphere, we need to begin to examine the way these forces interact to determine the performance of the vehicle. We know that the forces are dependent on things like atmospheric pressure, density, temperature and viscosity in combinations that become “similarity parameters” such as Reynolds number and Mach number. We also know that these parameters will vary as functions of altitude within the atmosphere and we have a model of a standard atmosphere to describe those variations. It is also obvious that the forces on an aircraft will be functions of speed and that this is part of both Reynolds number and Mach number.

Many of the questions we will have about aircraft performance are related to speed. How fast can the plane fly or how slow can it go? How quickly can the aircraft climb? What speed is necessary for lift-off from the runway?

In the previous section on dimensional analysis and flow similarity we found that the forces on an aircraft are not functions of speed alone but of a combination of velocity and density which acts as a pressure that we called dynamic pressure. This combination appears as one of the three terms in Bernoulli’s equation

$$P + \frac{1}{2}\rho V^2 = P_0 \quad (4.1)$$

which can be rearranged to solve for velocity

$$V = \sqrt{2(P_0 - P) / \rho} \quad (4.2)$$

In chapter two we learned how a Pitot-static tube can be used to measure the difference between the static and total pressure to find the airspeed if the density is either known or assumed. We discussed both the sea level equivalent airspeed which assumes sea level standard density in finding velocity and the true airspeed which uses the actual atmospheric density. In dealing with aircraft it is customary to refer to the sea level equivalent airspeed as the **indicated airspeed** if any instrument calibration or placement error can be neglected. In this text we will assume that such errors can indeed be neglected and the term indicated airspeed will be used interchangeably with sea level equivalent airspeed.

$$V_{IND} = V_e = V_{SL} = \sqrt{\frac{2(P_0 - P)}{\rho_{SL}}} \quad (4.3)$$

It should be noted that the equations above assume incompressible flow and are not accurate at speeds where compressibility effects are significant. In theory, compressibility effects must be considered at Mach numbers above 0.3; however, in reality, the above equations can be used without significant error to Mach numbers of 0.6 to 0.7.

The airspeed indication system of high speed aircraft must be calibrated on a more complicated basis which includes the speed of sound:

$$V_{IND} = \sqrt{\frac{2a_{sl}^2}{\gamma - 1} \left[\left(\frac{P_0 - P}{\rho_{SL}} + 1 \right)^{\frac{\gamma - 1}{\gamma}} - 1 \right]} \quad (4.4)$$

where a_{sl} = **speed of sound at sea level** and ρ_{SL} = **pressure at sea level**. Gamma is the ratio of specific heats (C_p/C_v) for air.

Very high speed aircraft will also be equipped with a Mach indicator since Mach number is a more relevant measure of aircraft speed at and above the speed of sound.

In the rest of this text it will be assumed that compressibility effects are negligible and the incompressible form of the equations can be used for all speed related calculations. Indicated airspeed (the speed which would be read by the aircraft pilot from the airspeed indicator) will be assumed equal to the sea level equivalent airspeed. Thus the true airspeed can be found by correcting for the difference in sea level and actual density. The correction is based on the knowledge that the relevant dynamic pressure at altitude will be equal to the dynamic pressure at sea level as found from the sea level equivalent airspeed:

$$\left(\frac{1}{2}\rho V^2\right)_{\text{alt}} \equiv \frac{1}{2}\rho_{SL}V_e^2$$

$$V_e = \sqrt{\frac{\rho}{\rho_{SL}}}V_{\text{alt}} = \sqrt{\sigma}V_{\text{alt}}$$

An important result of this equivalency is that, since the forces on the aircraft depend on dynamic pressure rather than airspeed, if we know the sea level equivalent conditions of flight and calculate the forces from those conditions, those forces (and hence the performance of the airplane) will be correctly predicted based on indicated airspeed and sea level conditions. This also means that the airplane pilot need not continually convert the indicated airspeed readings to true airspeeds in order to gauge the performance of the aircraft. The aircraft will always behave in the same manner at the same indicated airspeed regardless of altitude (within the assumption of incompressible flow). This is especially nice to know in take-off and landing situations!

4.1 Static Balance of Forces

Many of the important performance parameters of an aircraft can be determined using only statics; ie., assuming flight in an equilibrium condition such that there are no accelerations. This means that the flight is at constant altitude with no acceleration or deceleration. This gives the general arrangement of forces shown below.

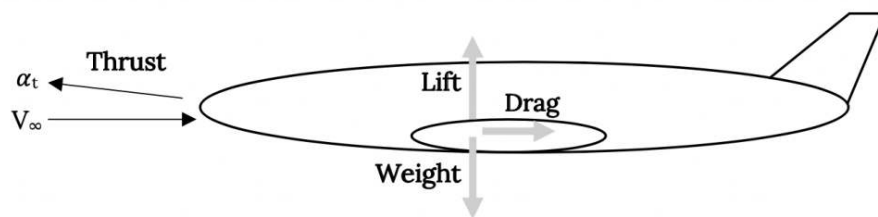

Figure 4.1 Static Force Balance in Straight and Level Flight

In this text we will consider the very simplest case where the thrust is aligned with the aircraft's velocity vector. We will also normally assume that the velocity vector is aligned with the direction of flight or flight path. For this most basic case the equations of motion become:

$$\mathbf{T} - \mathbf{D} = \mathbf{0}$$

$$\mathbf{L} - \mathbf{W} = \mathbf{0}$$

Note that this is consistent with the definition of lift and drag as being perpendicular and parallel to the velocity vector or relative wind.

Now we make a simple but very basic assumption that in straight and level flight lift is equal to weight,

$$\mathbf{L} = \mathbf{W}$$

We will use this so often that it will be easy to forget that it does assume that flight is indeed straight and level. Later we will cheat a little and use this in shallow climbs and glides, covering ourselves by assuming "quasi-straight and level" flight. In the final part of this text we will finally go beyond this assumption when we consider turning flight.

Using the definition of the lift coefficient

$$C_L = \frac{L}{\frac{1}{2}\rho V_{\infty}^2 S} \quad (4.5)$$

and the assumption that lift equals weight, the speed in straight and level flight becomes:

$$V = \sqrt{\frac{2W}{\rho S C_L}} \quad (4.6)$$

The thrust needed to maintain this speed in straight and level flight is also a function of the aircraft weight. Since $T = D$ and $L = W$ we can write

$$\mathbf{D/L} = \mathbf{T/W}$$

or

$$T = \frac{D}{L}W = \frac{C_D}{C_L}W$$

Therefore, for straight and level flight we find this relation between thrust and weight:

$$T = \frac{C_D}{C_L}W$$

The above equations for thrust and velocity become our first very basic relations which can be used to ascertain the performance of an aircraft.

4.2 Aerodynamic Stall

Earlier we discussed aerodynamic stall. For an airfoil (2-D) or wing (3-D), as the angle of attack is increased a point is reached where the increase in lift coefficient, which accompanies the increase in angle of attack, diminishes. When this occurs the lift coefficient versus angle of attack curve becomes non-linear as the flow over the upper surface of the wing begins to break away from the surface. This separation of flow may be gradual, usually progressing from the aft edge of the airfoil or wing and moving forward; sudden, as flow breaks away from large portions of the wing at the same time; or some combination of the two. The actual nature of stall will depend on the shape of the airfoil section, the wing planform and the Reynolds number of the flow.

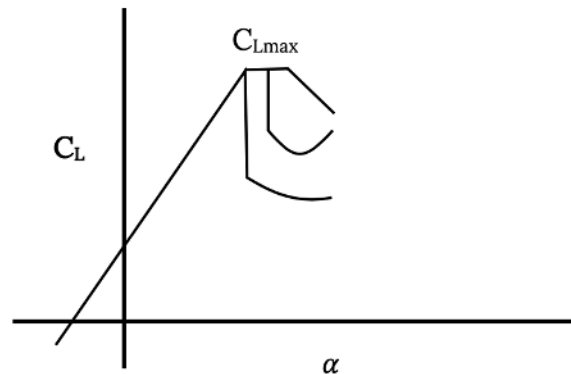

Figure 4.2 Different Types of Stall

We define the stall angle of attack as the angle where the lift coefficient reaches a maximum, C_{Lmax} , and use this value of lift coefficient to calculate a stall speed for straight and level flight.

$$V_{STALL} = \sqrt{\frac{2W}{\rho S C_{Lmax}}}$$

Note that the stall speed will depend on a number of factors including altitude. If we look at a sea level equivalent stall speed we have

$$V_{eSTALL} = \sqrt{\frac{2W}{\rho_{SL} S C_{Lmax}}}$$

It should be emphasized that stall speed as defined above is based on lift equal to weight or straight and level flight. This is the stall speed quoted in all aircraft operating manuals and used as a reference by pilots. It must be remembered that **stall is only a function of angle of attack and can occur at any speed**. The definition of stall speed used above results from limiting the flight to straight and level conditions where lift equals weight. This stall speed is not applicable for other flight conditions. For example, in a turn lift will normally exceed weight and stall will occur at a higher flight speed. The same is true in accelerated flight conditions such as climb. For this reason pilots are taught to handle stall in climbing and turning flight as well as in straight and level flight.

For most of this text we will deal with flight which is assumed straight and level and therefore will assume that the straight and level stall speed shown above is relevant. This speed usually represents the lowest practical straight and level flight speed for an

aircraft and is thus an important aircraft performance parameter.

We will normally define the stall speed for an aircraft in terms of the maximum gross takeoff weight but it should be noted that the weight of any aircraft will change in flight as fuel is used. For a given altitude, as weight changes the stall speed variation with weight can be found as follows:

$$V_{STALL2} = V_{STALL1} \sqrt{\frac{W_2}{W_1}}$$

It is obvious that as a flight progresses and the aircraft weight decreases, the stall speed also decreases. Since stall speed represents a lower limit of straight and level flight speed it is an indication that an aircraft can usually land at a lower speed than the minimum takeoff speed.

For many large transport aircraft the stall speed of the fully loaded aircraft is too high to allow a safe landing within the same distance as needed for takeoff. In cases where an aircraft must return to its takeoff field for landing due to some emergency situation (such as failure of the landing gear to retract), it must dump or burn off fuel before landing in order to reduce its weight, stall speed and landing speed. Takeoff and landing will be discussed in a later chapter in much more detail.

4.3 Perspectives on Stall

While discussing stall it is worthwhile to consider some of the physical aspects of stall and the many misconceptions that both pilots and the public have concerning stall.

To the aerospace engineer, stall is C_{Lmax} , the highest possible lifting capability of the aircraft; but, to most pilots and the public, stall is where the airplane loses all lift! How can it be both? And, if one of these views is wrong, why?

The key to understanding both perspectives of stall is understanding the difference between lift and lift coefficient. Lift is the product of the lift coefficient, the dynamic pressure and the wing planform area. For a given altitude and airplane (wing area) lift then depends on lift coefficient and velocity. It is possible to have a very high lift coefficient C_L and a very low lift if velocity is low.

When an airplane is at an angle of attack such that C_{Lmax} is reached, the high angle of attack also results in high drag coefficient. The resulting high drag normally leads to a reduction in airspeed which then results in a loss of lift. In a conventionally designed airplane this will be followed by a drop of the nose of the aircraft into a nose down attitude and a loss of altitude as speed is recovered and lift regained. If the pilot tries to hold the nose of the plane up, the airplane will merely drop in a nose up attitude. Pilots are taught to let the nose drop as soon as they sense stall so lift and altitude recovery can begin as rapidly as possible. A good flight instructor will teach a pilot to sense stall at its onset such that recovery can begin before altitude and lift is lost.

It should be noted that if an aircraft has sufficient power or thrust and the high drag present at C_{Lmax} can be matched by thrust, flight can be continued into the stall and post-stall region. This is possible on many fighter aircraft and the post-stall flight realm offers many interesting possibilities for maneuver in a “dog-fight”.

The general public tends to think of stall as when the airplane drops out of the sky. This can be seen in almost any newspaper report of an airplane accident where the story line will read “the airplane stalled and fell from the sky, nosediving into the ground after the engine failed”. This kind of report has several errors. Stall has nothing to do with engines and an engine loss does not cause stall. Sailplanes can stall without having an engine and every pilot is taught how to fly an airplane to a safe landing when an engine is lost. Stall also doesn’t cause a plane to go into a dive. It is, however, possible for a pilot to panic at the loss of an engine, inadvertently enter a stall, fail to take proper stall recovery actions and perhaps “nosedive” into the ground.

4.4 Drag and Thrust Required

As seen above, for straight and level flight, thrust must be equal to drag. Drag is a function of the drag coefficient C_D which is, in turn, a function of a base drag and an induced drag.

$$C_D = C_{D0} + C_{Di}$$

We assume that this relationship has a parabolic form and that the induced drag coefficient has the form

$$C_{Di} = KC_L^2$$

We therefore write

$$C_D = C_{D0} + KC_L^2$$

K is found from inviscid aerodynamic theory to be a function of the aspect ratio and planform shape of the wing

$$K = 1/(\pi AR e)$$

where e is unity for an ideal elliptical form of the lift distribution along the wing's span and less than one for non-ideal spanwise lift distributions.

The drag coefficient relationship shown above is termed a parabolic drag "polar" because of its mathematical form. It is actually only valid for inviscid wing theory not the whole airplane. In this text we will use this equation as a first approximation to the drag behavior of an entire airplane. While this is only an approximation, it is a fairly good one for an introductory level performance course. It can, however, result in some unrealistic performance estimates when used with some real aircraft data.

The drag of the aircraft is found from the drag coefficient, the dynamic pressure and the wing planform area:

$$D = C_D \left(\frac{1}{2} \rho V_\infty^2 S \right)$$

Therefore,

$$D = \left(C_{D0} + KC_L^2 \right) \frac{1}{2} \rho V_\infty^2 S$$

Realizing that for *straight and level flight*, lift is equal to weight and lift is a function of the wing's lift coefficient, we can write:

$$C_L = \frac{L}{\frac{1}{2} \rho V_\infty^2 S} = \frac{W}{\frac{1}{2} \rho V_\infty^2 S}$$

giving:

$$D = C_{D0} \frac{1}{2} \rho V_\infty^2 S + \frac{KW^2}{\frac{1}{2} \rho V_\infty^2 S}$$

The above equation is only valid for *straight and level flight* for an aircraft in incompressible flow with a parabolic drag polar.

Let's look at the form of this equation and examine its physical meaning. For a given aircraft at a given altitude most of the terms in the equation are constants and we can write

$$D = AV^2 + \frac{B}{V^2}$$

where

$$A = \frac{1}{2} \rho S C_{D0}$$

$$B = \frac{KW^2}{\frac{1}{2} \rho S}$$

The first term in the equation shows that part of the drag increases with the square of the velocity. This is the base drag term and it is logical that for the basic airplane shape the drag will increase as the dynamic pressure increases. To most observers this is somewhat intuitive.

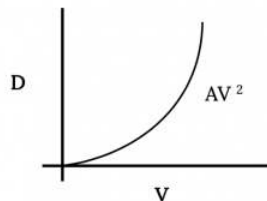

Figure 4.3: Part of Drag Increases With Velocity Squared

The second term represents a drag which decreases as the square of the velocity increases. It gives an infinite drag at zero speed, however, this is an unreachable limit for normally defined, fixed wing (as opposed to vertical lift) aircraft. It should be noted that this term includes the influence of lift or lift coefficient on drag. The faster an aircraft flies, the lower the value of lift coefficient needed to give a lift equal to weight. Lift coefficient, it is recalled, is a linear function of angle of attack (until stall). If an aircraft is flying straight and level and the pilot maintains level flight while decreasing the speed of the plane, the wing angle of attack must increase in order to provide the lift coefficient and lift needed to equal the weight. As angle of attack increases it is somewhat intuitive that the drag of the wing will increase. As speed is decreased in straight and level flight, this part of the drag will continue to increase exponentially until the stall speed is reached.

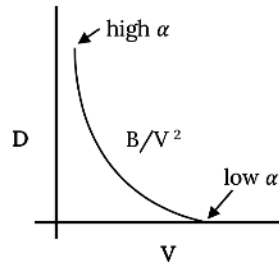

Figure 4.4: Part of Drag Decreases With Velocity Squared

Adding the two drag terms together gives the following figure which shows the complete drag variation with velocity for an aircraft with a parabolic drag polar in straight and level flight.

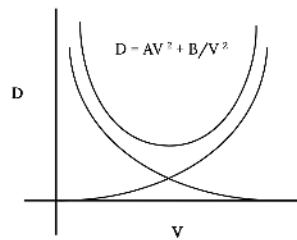

Figure 4.5: Total Drag Variation With Velocity

4.5 Minimum Drag

One obvious point of interest on the previous drag plot is the velocity for minimum drag. This can, of course, be found graphically from the plot. We can also take a simple look at the equations to find some other information about conditions for minimum drag.

The requirements for minimum drag are intuitively of interest because it seems that they ought to relate to economy of flight in some way. Later we will find that there are certain performance optima which do depend directly on flight at minimum drag conditions.

At this point we are talking about finding the velocity at which the airplane is flying at minimum drag conditions in *straight and level* flight. It is important to keep this assumption in mind. We will later find that certain climb and glide optima occur at these same conditions and we will stretch our straight and level assumption to one of “*quasi*”-level flight.

We can begin with a very simple look at what our lift, drag, thrust and weight balances for straight and level flight tells us about minimum drag conditions and then we will move on to a more sophisticated look at how the wing shape dependent terms in the drag polar equation (CD0 and K) are related at the minimum drag condition. Ultimately, the most important thing to determine is the speed for flight at minimum drag because the pilot can then use this to fly at minimum drag conditions.

Let's look at our simple static force relationships:

$$L = W, T = D$$

to write

$$D = W \times D/L$$

which says that **minimum drag occurs** when the *drag divided by lift* is a minimum or, inversely, **when lift divided by drag is a maximum**.

This combination of parameters, **L/D**, occurs often in looking at aircraft performance. In general, it is usually intuitive that the higher the lift and the lower the drag, the better an airplane. It is not as intuitive that the maximum lift-to drag ratio occurs at the same flight conditions as minimum drag. This simple analysis, however, shows that

MINIMUM DRAG OCCURS WHEN L/D IS MAXIMUM.

Note that since $C_L / C_D = L/D$ we can also say that minimum drag occurs when C_L/C_D is maximum. **It is very important to note that minimum drag does not connote minimum drag coefficient.**

Minimum drag occurs at a single value of angle of attack where the lift coefficient divided by the drag coefficient is a maximum:

$$D_{\min} \text{ occurs when } (C_L/C_D)_{\max}$$

As noted above, this is **not at the same angle of attack at which CD is at a minimum**. It is also **not the same angle of attack where lift coefficient is maximum**. This should be rather obvious since $C_{L\max}$ occurs at stall and drag is very high at stall.

$$\left(\frac{C_L}{C_D}\right)_{\max} \neq \frac{C_{L\max}}{C_{D\min}}$$

Since minimum drag is a function only of the ratio of the lift and drag coefficients and not of altitude (density), the actual value of the minimum drag for a given aircraft at a given weight will be invariant with altitude. The actual velocity at which minimum drag occurs is a function of altitude and will generally increase as altitude increases.

If we assume a parabolic drag polar and plot the drag equation

$$D = C_{D0} \frac{1}{2} \rho V_{\infty}^2 S + 2KW^2 / \rho S V_{\infty}^2$$

for drag versus velocity at different altitudes the resulting curves will look somewhat like the following:

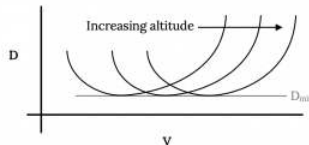

Figure 4.6: Altitude Effect on Drag Variation

Note that the **minimum drag will be the same at every altitude** as mentioned earlier and the velocity for minimum drag will increase with altitude.

We discussed in an earlier section the fact that because of the relationship between dynamic pressure at sea level with that at altitude, the aircraft would always perform the same at the same indicated or sea level equivalent airspeed. Indeed, if one writes the drag equation as a function of sea level density and sea level equivalent velocity a single curve will result.

$$1/2 \rho V^2 \equiv 1/2 \rho_{SL} V_e^2$$

$$D = C_{D0} 1/2 \rho_{SL} V_e^2 S + (2KW^2) / \rho_{SL} V_e^2 S$$

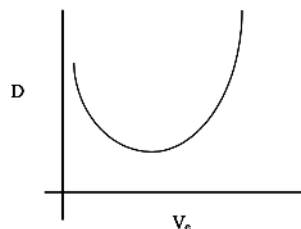

Figure 4.7: Drag Versus Sea Level Equivalent (Indicated) Velocity

To find the drag versus velocity behavior of an aircraft it is then only necessary to do calculations or plots at sea level conditions and then convert to the true airspeeds for flight at any altitude by using the velocity relationship below.

$$V_{alt} = V_e (\rho_{SL} / \rho_{alt})^{1/2}$$

4.6 Minimum Drag Summary

We know that minimum drag occurs when the lift to drag ratio is at a maximum, but when does that occur; at what value of C_L or C_D or at what speed?

One way to find C_L and C_D at minimum drag is to plot one versus the other as shown below. The maximum value of the ratio of lift coefficient to drag coefficient will be where a line from the origin just tangent to the curve touches the curve. At this point are the values of C_L and C_D for minimum drag. This graphical method of finding the minimum drag parameters works for any aircraft even if it does not have a parabolic drag polar.

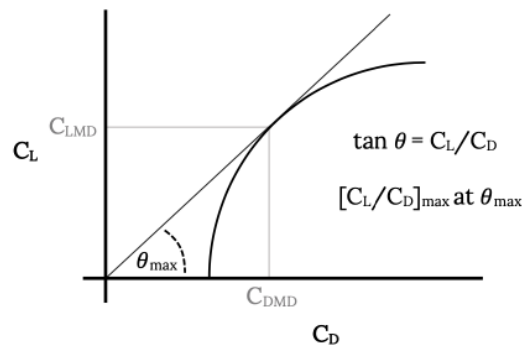

Figure 4.8: Graphical Method for Determining Minimum Drag Conditions

Once C_{LMD} and C_{DMD} are found, the velocity for minimum drag is found from the equation below, provided the aircraft is in straight and level flight

$$V_{MD} = \sqrt{\frac{2W}{\rho S C_{LMD}}}$$

As we already know, the velocity for minimum drag can be found for sea level conditions (the sea level equivalent velocity) and from that it is easy to find the minimum drag speed at altitude.

$$V_{eMD} = \sqrt{\frac{2W}{\rho_{SL} S C_{LMD}}}$$

It should also be noted that when the lift and drag coefficients for minimum drag are known and the weight of the aircraft is known the minimum drag itself can be found from

$$D_{min} = \frac{W}{(L/D)_{max}}$$

It is common to assume that the relationship between drag and lift is the one we found earlier, the so called *parabolic drag polar*. For the parabolic drag polar

$$C_D = C_{D0} + K C_L^2$$

it is easy to take the derivative with respect to the lift coefficient and set it equal to zero to determine the conditions for the minimum ratio of drag coefficient to lift coefficient, which was a condition for minimum drag.

$$\frac{C_D}{C_L} = \frac{C_{D0} + K C_L^2}{C_L}$$

Hence,

$$\frac{d\left(\frac{C_D}{C_L}\right)}{dC_L} = \frac{C_L(2KC_L) - C_{D0} - KC_L^2}{C_L^2} = 0$$

This gives

$$2K - K - C_{DO}/C_L^2 = 0$$

or

$$\frac{C_{DO}}{C_L^2} = K$$

and

$$C_{DO} = KC_{L_{MD}}^2$$

The above is the condition required for minimum drag with a parabolic drag polar.

Now, we return to the drag polar

$$C_D = C_{DO} + KC_L^2$$

and for minimum drag we can write

$$C_{D_{MD}} = C_{DO} + KC_{L_{MD}}^2$$

which, with the above, gives

$$C_{D_{MD}} = 2C_{DO} = 2KC_{L_{MD}}^2$$

or

$$C_{L_{MD}} = \sqrt{\frac{C_{DO}}{K}}$$

From this we can find the value of the maximum lift-to-drag ratio in terms of basic drag parameters

$$(L/D)_{\max} = \frac{C_{L_{MD}}}{C_{D_{MD}}} = \frac{\sqrt{C_{DO}/K}}{2C_{DO}}$$

$$(L/D)_{\max} = \frac{1}{2\sqrt{C_{DO}K}}$$

And the speed at which this occurs in *straight and level flight* is

$$V_{MD} = \sqrt{\frac{2W}{\rho S C_{L_{MD}}}} = \sqrt{\frac{2W}{\rho S \sqrt{C_{DO}/K}}}$$

So we can write the minimum drag velocity as

$$V_{MD} = \sqrt{\frac{2W}{\rho S}} \sqrt{\frac{K}{C_{DO}}}$$

or the sea level equivalent minimum drag speed as

$$V_{eMD} = \sqrt{\frac{2W}{\rho_{SL} S}} \sqrt{\frac{K}{C_{DO}}}$$

4.7 Review: Minimum Drag Conditions for a Parabolic Drag Polar

At this point we know a lot about minimum drag conditions for an aircraft with a **parabolic drag polar in straight and level flight**. The following equations may be useful in the solution of many different performance problems to be considered later in this text. There will be several flight conditions which will be found to be optimized when flown at minimum drag conditions. It is therefore suggested that the student write the following equations on a separate page in her or his class notes for easy reference.

$$D_{\min} = \frac{W}{(L/D)_{\max}} = 2W\sqrt{C_{DO}K}$$

$$C_{D_{MD}} = 2C_{DO} = 2KC_{L_{MD}}^2$$

$$C_{L_{MD}} = \sqrt{C_{DO}/K}$$

$$V_{MD} = \sqrt{\frac{2W}{\rho S}} \sqrt{\frac{K}{C_{DO}}}$$

$$(L/D)_{\max} = 1/2\sqrt{C_{DO}K}$$

EXAMPLE 4.1

An aircraft which weighs 3000 pounds has a wing area of 175 square feet and an aspect ratio of seven with a wing aerodynamic efficiency factor (e) of 0.95. If the base drag coefficient, C_{DO} , is 0.028, find the minimum drag at sea level and at 10,000 feet altitude, the maximum lift-to-drag ratio and the values of lift and drag coefficient for minimum drag. Also find the velocities for minimum drag in straight and level flight at both sea level and 10,000 feet. We need to first find the term K in the drag equation.

$$K = 1 / (\pi A R e) = 0.048$$

Now we can find

$$\begin{aligned} D_{\min} &= 2W \cdot \sqrt{C_{DO} K} = 220lb \\ C_{D_{MD}} &= 2C_{DO} = 0.056 \\ C_{L_{MD}} &= \sqrt{\frac{C_{DO}}{K}} = 0.764 \\ (L/D)_{\min} &= C_{L_{MD}} / C_{D_{MD}} = \frac{0.764}{0.056} = 13.64 \end{aligned}$$

We can check this with

$$(L/D)_{MAX} = \frac{2}{2\sqrt{C_{DO} K}} = \frac{1}{0.0733} = 13.64$$

The velocity for minimum drag is the first of these that depends on altitude.

$$V_{MD} = \sqrt{\frac{2W}{\rho S}} \sqrt{\frac{K}{C_{DO}}}$$

At sea level

$$V_{MD_{SL}} = \sqrt{14,430 \frac{ft^2}{sec^2}} \sqrt{\frac{0.048}{0.028}} = 137.5ft/sec$$

To find the velocity for minimum drag at 10,000 feet we can recalculate using the density at that altitude or we can use

$$V_{MD_{ALT}} = \sqrt{\sigma} V_{MD_{SL}} \quad V_{MD_{10K}} = \sqrt{\frac{\rho_{SL}}{\rho_{10K}}} V_{MD_{SL}} = \sqrt{\frac{0.002376}{0.001756}} (137.5) = 160ft/sec$$

It is suggested that at this point the student use the drag equation

$$D = C_{DO} \left(\frac{1}{2} \rho V_{\infty}^2 S \right) + 2KW^2 / \rho V_{\infty}^2 S$$

and make graphs of drag versus velocity for both sea level and 10,000 foot altitude conditions, plotting drag values at 20 fps increments. The plots would confirm the above values of minimum drag velocity and minimum drag.

4.8 Flying at Minimum Drag

One question which should be asked at this point but is usually not answered in a text on aircraft performance is “**Just how the heck does the pilot make that airplane fly at minimum drag conditions anyway?**”

The answer, quite simply, is to fly at the sea level equivalent speed for minimum drag conditions. The pilot sets up or “trims” the aircraft to fly at constant altitude (*straight and level*) at the indicated airspeed (sea level equivalent speed) for minimum drag as given in the aircraft operations manual. **All the pilot need do is hold the speed and altitude constant.**

4.9 Drag in Compressible Flow

For the purposes of an introductory course in aircraft performance we have limited ourselves to the discussion of lower speed aircraft; ie, airplanes operating in incompressible flow. As discussed earlier, analytically, this would restrict us to consideration of flight speeds of Mach 0.3 or less (less than 300 fps at sea level), however, physical realities of the onset of drag rise due to compressibility effects allow us to extend our use of the incompressible theory to Mach numbers of around 0.6 to 0.7. This is the range of Mach number where supersonic flow over places such as the upper surface of the wing has reached the magnitude that shock waves may occur during flow deceleration resulting in energy losses through the shock and in drag rises due to shock-induced flow separation over the wing surface. This drag rise was discussed in Chapter 3.

As speeds rise to the region where compressibility effects must be considered we must take into account the speed of sound a and the ratio of specific heats of air, γ .

$$a^2 = \gamma RT = \gamma P / \rho, \quad \gamma = C_p / C_v, \quad P = \rho RT$$

Gamma for air at normal lower atmospheric temperatures has a value of 1.4.

Starting again with the relation for a parabolic drag polar, we can multiply and divide by the speed of sound to rewrite the relation in terms of Mach number.

$$D = \left[C_{D0} \frac{1}{2} \rho V^2 S + 2KW^2 / \rho SV^2 \right] \frac{\gamma P}{\gamma P}$$

where

$$M^2 = V^2 / a^2 = \rho V^2 / \gamma P$$

or

$$D = \frac{\gamma}{2} S P C_{D0} M^2 + 2W^2 K / \gamma S P M^2$$

The resulting equation above is very similar in form to the original drag polar relation and can be used in a similar fashion. For example, to find the Mach number for minimum drag in straight and level flight we would take the derivative with respect to Mach number and set the result equal to zero. The complication is that some terms which we considered constant under incompressible conditions such as K and C_{D0} may now be functions of Mach number and must be so evaluated.

$$\frac{dD}{dM} = \gamma S P C_{D0} M + \frac{\gamma S P M^2}{2} \frac{dC_{D0}}{dM} - \frac{4W^2 K}{\gamma S P M^2} + \frac{2W^2}{\gamma S P M^2} \frac{dK}{dM} = 0$$

Often the equation above must be solved iteratively.

4.10 Review

To this point we have examined the drag of an aircraft based primarily on a simple model using a *parabolic drag representation in incompressible flow*. We have further restricted our analysis to *straight and level flight* where lift is equal to weight and thrust equals drag.

The aircraft can fly straight and level at a wide range of speeds, provided there is sufficient power or thrust to equal or overcome the drag at those speeds. The student needs to understand the physical aspects of this flight.

We looked at the speed for straight and level flight at minimum drag conditions. One could, of course, always cruise at that speed and it might, in fact, be a very economical way to fly (we will examine this later in a discussion of range and endurance). However, since “time is money” there may be reason to cruise at higher speeds. It also might just be more fun to fly faster. Flight at higher than minimum-drag speeds will require less angle of attack to produce the needed lift (to equal weight) and the upper speed limit will be determined by the maximum thrust or power available from the engine.

Cruise at lower than minimum drag speeds may be desired when flying approaches to landing or when flying in holding patterns or when flying other special purpose missions. This will require a higher than minimum-drag angle of attack and the use of more thrust or power to overcome the resulting increase in drag. The lower limit in speed could then be the result of the drag reaching the magnitude of the power or the thrust available from the engine; however, it will normally result from the angle of attack reaching the stall angle. Hence, stall speed normally represents the lower limit on straight and level cruise speed.

It must be remembered that all of the preceding is based on an assumption of *straight and level flight*. If an aircraft is flying straight and level at a given speed and power or thrust is added, the plane will initially both accelerate and climb until a new straight and level equilibrium is reached at a higher altitude. The pilot can control this addition of energy by changing the plane’s attitude (angle of attack) to direct the added energy into the desired combination of speed increase and/or altitude increase. If the engine output is decreased, one would normally expect a decrease in altitude and/or speed, depending on pilot control input.

We must now add the factor of engine output, either thrust or power, to our consideration of performance. It is normal to refer to the output of a jet engine as thrust and of a propeller engine as power. We will first consider the simpler of the two cases, thrust.

4.11 Thrust

We have said that for an aircraft in straight and level flight, thrust must equal drag. If the thrust of the aircraft's engine exceeds the drag for straight and level flight at a given speed, the airplane will either climb or accelerate or do both. It could also be used to make turns or other maneuvers. The **drag** encountered in straight and level flight could therefore be called the **thrust required** (for straight and level flight). The thrust actually produced by the engine will be referred to as the **thrust available**.

Although we can speak of the output of any aircraft engine in terms of thrust, it is conventional to refer to the **thrust of jet engines** and the **power of prop engines**. A propeller, of course, produces thrust just as does the flow from a jet engine; however, for an engine powering a propeller (either piston or turbine), the output of the engine itself is **power** to a shaft. Thus when speaking of such a propulsion system most references are to its power. When speaking of the propeller itself, thrust terminology may be used.

The units employed for discussions of thrust are Newtons in the SI system and pounds in the English system. Since the English units of pounds are still almost universally used when speaking of thrust, they will normally be used here.

Thrust is a function of many variables including efficiencies in various parts of the engine, throttle setting, altitude, Mach number and velocity. A complete study of engine thrust will be left to a later propulsion course. For our purposes very simple models of thrust will suffice with assumptions that thrust varies with density (altitude) and throttle setting and possibly, velocity. We already found one such relationship in Chapter two with the momentum equation. Often we will simplify things even further and assume that thrust is invariant with velocity for a simple jet engine.

If we know the thrust variation with velocity and altitude for a given aircraft we can add the engine thrust curves to the drag curves for straight and level flight for that aircraft as shown below. We will normally assume that since we are interested in the limits of performance for the aircraft we are only interested in the case of 100% throttle setting. It is obvious that other throttle settings will give thrusts at any point below the 100% curves for thrust.

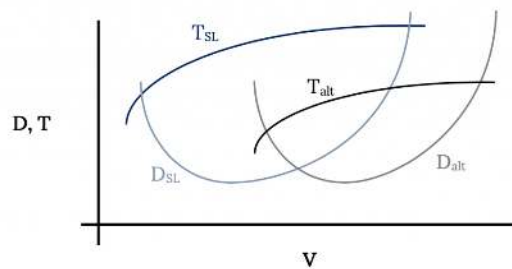

Figure 4.9: Thrust and Drag Variation With Velocity

In the figure above it should be noted that, although the terminology used is **thrust and drag**, it may be more meaningful to call these curves **thrust available and thrust required** when referring to the engine output and the aircraft drag, respectively.

4.12 Minimum and Maximum Speeds

The intersections of the thrust and drag curves in the figure above obviously represent the minimum and maximum flight speeds in straight and level flight. Above the maximum speed there is insufficient thrust available from the engine to overcome the drag (thrust required) of the aircraft at those speeds. The same is true below the lower speed intersection of the two curves.

The true lower speed limitation for the aircraft is usually imposed by stall rather than the intersection of the thrust and drag curves. Stall speed may be added to the graph as shown below:

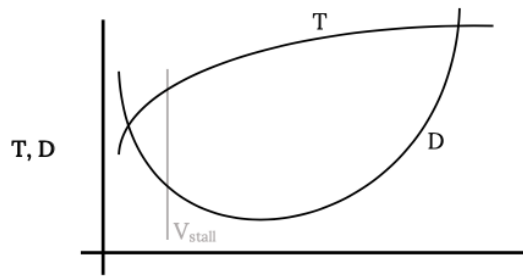

Figure 4.10: Minimum and Maximum Speeds for Straight & Level Flight

The area between the thrust available and the drag or thrust required curves can be called the flight envelope. The aircraft can fly straight and level at any speed between these upper and lower speed intersection points. Between these speed limits there is excess thrust available which can be used for flight other than straight and level flight. This excess thrust can be used to climb or turn or maneuver in other ways. We will look at some of these maneuvers in a later chapter. For now we will limit our investigation to the realm of straight and level flight.

Note that at the higher altitude, the decrease in thrust available has reduced the “flight envelope”, bringing the upper and lower speed limits closer together and reducing the excess thrust between the curves. As thrust is continually reduced with increasing altitude, the flight envelope will continue to shrink until the upper and lower speeds become equal and the two curves just touch. This can be seen more clearly in the figure below where all data is plotted in terms of sea level equivalent velocity. In the example shown, the thrust available at h_6 falls entirely below the drag or thrust required curve. This means that the aircraft can not fly straight and level at that altitude. That altitude is said to be above the “ceiling” for the aircraft. At some altitude between h_5 and h_6 feet there will be a thrust available curve which will just touch the drag curve. That altitude will be the ceiling altitude of the airplane, the altitude at which the plane can only fly at a single speed. We will have more to say about ceiling definitions in a later section.

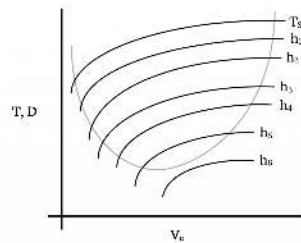

Figure 4.11: Thrust Variation With Altitude vs Sea Level Equivalent Speed

Another way to look at these same speed and altitude limits is to plot the intersections of the thrust and drag curves on the above figure against altitude as shown below. This shows another version of a flight envelope in terms of altitude and velocity. This type of plot is more meaningful to the pilot and to the flight test engineer since speed and altitude are two parameters shown on the standard aircraft instruments and thrust is not.

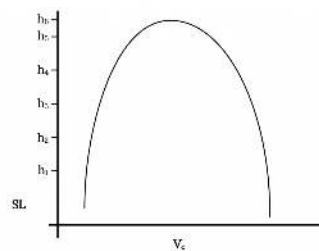

Figure 4.12: Straight & Level Flight Speed Envelope With Altitude

It may also be meaningful to add to the figure above a plot of the same data using actual airspeed rather than the indicated or sea level equivalent airspeeds. This can be done rather simply by using the square root of the density ratio (sea level to altitude) as discussed earlier to convert the equivalent speeds to actual speeds. This is shown on the graph below. Note that at sea level $V = V_e$ and also there will be some altitude where there is a maximum true airspeed.

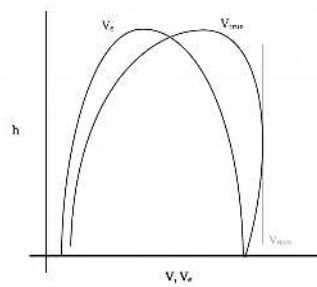

Figure 4.13: True Maximum Airspeed Versus Altitude

4.13 Special Case of Constant Thrust

A very simple model is often employed for thrust from a jet engine. The assumption is made that thrust is constant at a given altitude. We will use this assumption as our standard model for all jet aircraft unless otherwise noted in examples or problems. Later we will discuss models for variation of thrust with altitude.

The above model (constant thrust at altitude) obviously makes it possible to find a rather simple analytical solution for the intersections of the thrust available and drag (thrust required) curves. We will let thrust equal a constant

$$\mathbf{T = T_0}$$

therefore, in straight and level flight where thrust equals drag, we can write

$$T_0 = D = C_D \left(\frac{1}{2} \rho V_\infty^2 S \right) = C_D q S$$

where q is a commonly used abbreviation for the dynamic pressure.

$$T_0 = C_{D0} q S + K W^2 / q S$$

or

$$T_0 q S = C_{D0} (q S)^2 + K W^2$$

and rearranging as a quadratic equation

$$C_{D0} (q S)^2 - T_0 (q S) + K W^2 = 0$$

Solving the above equation gives

$$q S = \frac{T_0}{2 C_{D0}} \pm \frac{1}{2} \sqrt{\frac{T_0^2}{C_{D0}^2} - \frac{4 K W^2}{C_{D0}}}$$

or

$$V^2 = \frac{T_0}{C_{D0} \rho S} \pm \sqrt{\left(\frac{T_0}{C_{D0} \rho S} \right)^2 - \frac{4 K W^2}{C_{D0} \rho^2 S^2}}$$

In terms of the sea level equivalent speed

$$V_e^2 = \frac{T_0}{C_{D0} \rho_{SL} S} \pm \sqrt{\left(\frac{T_0}{C_{D0} \rho_{SL} S} \right)^2 - \frac{4 K W^2}{C_{D0} \rho_{SL}^2 S^2}}$$

These solutions are, of course, double valued. The higher velocity is the maximum straight and level flight speed at the altitude under consideration and the lower solution is the nominal minimum straight and level flight speed (the stall speed will probably be a higher speed, representing the true minimum flight speed).

There are, of course, other ways to solve for the intersection of the thrust and drag curves. Sometimes it is convenient to solve the equations for the lift coefficients at the minimum and maximum speeds. To set up such a solution we first return to the basic straight and level flight equations $T = T_0 = D$ and $L = W$.

$$\frac{T_0}{W} = \frac{D}{L} = \frac{C_D}{C_L} = \frac{C_{DO} + KC_L^2}{C_L}$$

$$\frac{T}{W} C_L = C_{DO} + KC_L^2$$

or

$$C_L^2 - \frac{T_0}{W} \frac{C_L}{K} + \frac{C_{DO}}{K} = 0$$

solving for C_L

$$C_L = \frac{T_0}{2KW} \pm \frac{1}{2} \sqrt{\left(\frac{T_0}{KW}\right)^2 - \frac{4C_{DO}}{K}}$$

This solution will give two values of the lift coefficient. The larger of the two values represents the **minimum flight speed** for straight and level flight while the **smaller** C_L is for the maximum flight speed. The matching speed is found from the relation

$$V = \sqrt{\frac{2W}{\rho S C_L}}$$

4.14 Review for Constant Thrust

The figure below shows graphically the case discussed above. From the solution of the thrust equals drag relation we obtain two values of either lift coefficient or speed, one for the maximum straight and level flight speed at the chosen altitude and the other for the minimum flight speed. The stall speed will probably exceed the minimum straight and level flight speed found from the thrust equals drag solution, making it the true minimum flight speed.

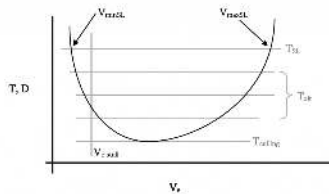

Figure 4.14: Graphical Solution for Constant Thrust at Each Altitude

As altitude increases T_0 will normally decrease and V_{MIN} and V_{MAX} will move together until at a ceiling altitude they merge to become a single point.

It is normally assumed that the thrust of a jet engine will vary with altitude in direct proportion to the variation in density. This assumption is supported by the thrust equations for a jet engine as they are derived from the momentum equations introduced in chapter two of this text. We can therefore write:

$$T_{ALT} = \sigma T_{SL} = \frac{\rho_{ALT}}{\rho_{SL}} T_{SL}$$

EXAMPLE 4.2

Earlier in this chapter we looked at a 3000 pound aircraft with a 175 square foot wing area, aspect ratio of seven and C_{DO} of 0.028 with $e = 0.95$. Let us say that the aircraft is fitted with a small jet engine which has a constant thrust at sea level of 400 pounds. Find the maximum and minimum straight and level flight speeds for this aircraft at sea level and at 10,000 feet assuming that thrust available varies proportionally to density.

If, as earlier suggested, the student, plotted the drag curves for this aircraft, a graphical solution is simple. One need only add a straight line representing 400 pounds to the sea level plot and the intersections of this line with the sea level drag curve give the answer. The same can be done with the 10,000 foot altitude data, using a constant thrust reduced in proportion to the density.

Given a standard atmosphere density of 0.001756 sl/ft^3 , the thrust at 10,000 feet will be 0.739 times the sea level thrust or 296 pounds. Using the two values of thrust available we can solve for the velocity limits at sea level and at 10,000 ft.

$$V_{SL}^2 = \frac{T_0}{C_{DO}\rho_{SL}S} \pm \sqrt{\left(\frac{T_0}{C_{DO}\rho_{SL}S}\right)^2 - \frac{4KW^2}{C_{DO}\rho_{SL}^2S^2}} = 34357 \pm \sqrt{8.2346 \times 10^8}$$

$$= 63053 \text{ or } 5661$$

$$V_{SL} = 251 \text{ ft/sec (max)}$$

$$\text{or } = 75 \text{ ft/sec (min)}$$

Thus the equation gives maximum and minimum straight and level flight speeds as 251 and 75 feet per second respectively.

It is suggested that the student do similar calculations for the 10,000 foot altitude case. Note that one cannot simply take the sea level velocity solutions above and convert them to velocities at altitude by using the square root of the density ratio. The equations must be solved again using the new thrust at altitude. The student should also compare the analytical solution results with the graphical results.

As mentioned earlier, the stall speed is usually the actual minimum flight speed. If the maximum lift coefficient has a value of 1.2, find the stall speeds at sea level and add them to your graphs.

4.15 Performance in Terms of Power

The engine output of all propeller powered aircraft is expressed in terms of power. Power is really energy per unit time. While the propeller output itself may be expressed as thrust if desired, it is common to also express it in terms of power.

While at first glance it may seem that power and thrust are very different parameters, they are related in a very simple manner through velocity. Power is thrust multiplied by velocity. The units for power are Newton-meters per second or **watts** in the SI system and **horsepower** in the English system. As before, we will use primarily the English system. The reason is rather obvious. The author challenges anyone to find any pilot, mechanic or even any automobile driver anywhere in the world who can state the power rating for their engine in watts! Watts are for light bulbs: horsepower is for engines!

Actually, our equations will result in English system power units of foot-pounds per second. The conversion is

$$\text{one HP} = 550 \text{ foot-pounds/second.}$$

We will speak of two types of power; **power available** and **power required**. **Power required** is the power needed to overcome the drag of the aircraft

$$P_{\text{req}} = D \times V$$

Power available is equal to the thrust multiplied by the velocity.

$$P_{\text{av}} = T \times V$$

It should be noted that we can start with power and find thrust by dividing by velocity, or we can multiply thrust by velocity to find power. There is no reason for not talking about the thrust of a propeller propulsion system or about the power of a jet engine. The use of power for propeller systems and thrust for jets merely follows convention and also recognizes that for a jet, thrust is relatively constant with speed and for a prop, power is relatively invariant with speed.

Power available is the power which can be obtained from the propeller. Recognizing that there are losses between the engine and propeller we will distinguish between **power available** and **shaft horsepower**. **Shaft horsepower** is the power transmitted through the crank or drive shaft to the propeller from the engine. The engine may be piston or turbine or even electric or steam. The propeller turns this shaft power (P_s) into propulsive power with a certain propulsive efficiency, η_p .

$$P_{\text{av}} = \eta_p P_s$$

The propulsive efficiency is a function of propeller speed, flight speed, propeller design and other factors.

It is obvious that both power available and power required are functions of speed, both because of the velocity term in the relation and from the variation of both drag and thrust with speed. For the ideal jet engine which we assume to have a constant thrust, the variation in power available is simply a linear increase with speed.

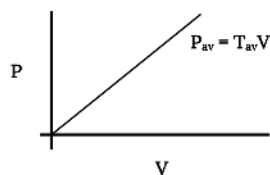

Figure 4.15: Power Available Varies Linearly With Velocity

It is interesting that if we are working with a jet where thrust is constant with respect to speed, the equations above give **zero power at zero speed**. This is not intuitive but is nonetheless true and will have interesting consequences when we later examine rates of climb.

Another consequence of this relationship between thrust and power is that if power is assumed constant with respect to speed (as we will do for prop aircraft) **thrust becomes infinite as speed approaches zero**. This means that a Cessna 152 when standing still with the engine running has infinitely more thrust than a Boeing 747 with engines running full blast. It also has more power! **What an ego boost for the private pilot!**

In using the concept of power to examine aircraft performance we will do much the same thing as we did using thrust. We will speak of the intersection of the power required and power available curves determining the maximum and minimum speeds. We will find the speed for minimum power required. We will look at the variation of these with altitude. The graphs we plot will look like that below.

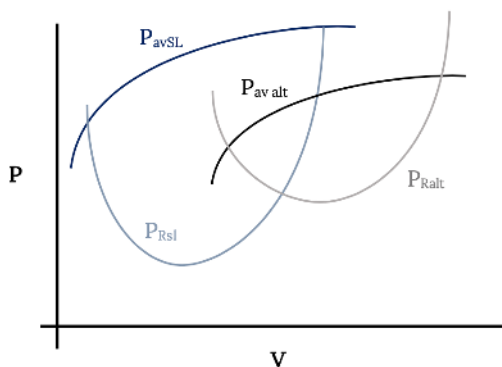

Figure 4.16: Power Required and Available Variation With Altitude

While the maximum and minimum straight and level flight speeds we determine from the power curves will be identical to those found from the thrust data, there will be some differences. One difference can be noted from the figure above. Unlike minimum drag, which was the same magnitude at every altitude, minimum power will be different at every altitude. This means it will be more complicated to collapse the data at all altitudes into a single curve.

4.16 Power Required

The power required plot will look very similar to that seen earlier for thrust required (drag). It is simply the drag multiplied by the velocity. If we continue to assume a parabolic drag polar with constant values of C_{D0} and K we have the following relationship for power required:

$$P = DV = C_D \left(\frac{1}{2} \rho V_\infty^3 S \right) = C_{D0} \frac{1}{2} \rho V_\infty^3 S + \frac{2KW^2}{\rho V_\infty S}$$

We can plot this for given values of C_{D0} , K , W and S (for a given aircraft) for various altitudes as shown in the following example.

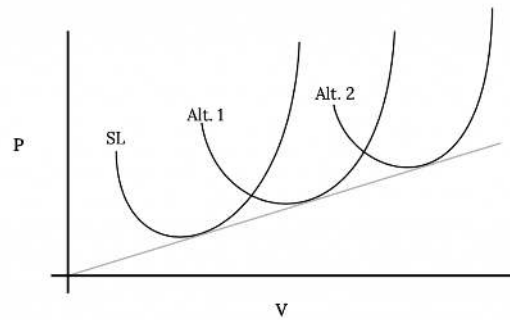

Figure 4.17: Power Required Variation With Altitude

We will note that the minimum values of power will not be the same at each altitude. Recalling that the minimum values of drag were the same at all altitudes and that power required is drag times velocity, it is logical that the minimum value of power increases linearly with velocity. We should be able to draw a straight line from the origin through the minimum power required points at each altitude.

The **minimum power required** in straight and level flight can, of course be taken from plots like the one above. We would also like to determine the values of lift and drag coefficient which result in minimum power required just as we did for minimum drag.

One might assume at first that minimum power for a given aircraft occurs at the same conditions as those for minimum drag. This is, of course, not true because of the added dependency of power on velocity. We can begin to understand the parameters which influence minimum required power by again returning to our simple force balance equations for straight and level flight:

$$D = D \frac{W}{L} = W \frac{C_D}{C_L}, \quad V = \sqrt{\frac{2W}{\rho S C_L}}$$

$$P_R = DV = W \frac{C_D}{C_L} V = W \frac{C_D}{C_L} \sqrt{\frac{2W}{\rho S C_L}}$$

$$P_R = \sqrt{\frac{2W^3}{\rho S}} \frac{C_D}{C_L^{3/2}}$$

Thus, for a given aircraft (weight and wing area) and altitude (density) the minimum required power for straight and level flight occurs when the drag coefficient divided by the lift coefficient to the two-thirds power is at a minimum.

$$P_{R_{\min}} \text{ when } \left(\frac{C_D}{C_L^{3/2}} \right)_{\min}$$

Assuming a parabolic drag polar, we can write an equation for the above ratio of coefficients and take its derivative with respect to the lift coefficient (since C_L is linear with angle of attack this is the same as looking for a maximum over the range of angle of attack) and set it equal to zero to find a maximum.

$$\frac{d}{dC_L} \left(\frac{C_D}{C_L^{3/2}} \right) = \frac{d}{dC_L} \left(\frac{C_{D0} + KC_L^2}{C_L^{3/2}} \right) = 0$$

$$C_L^{3/2} (2KC_L) - (C_{D0} + KC_L^2) \frac{3}{2} C_L^{1/2} = 0$$

$$3C_{D0} = KC_L^2$$

$$C_{L_{\min P}} = \sqrt{\frac{3C_{D0}}{K}}$$

Note that

$$C_{L_{MP}} = \sqrt{3} C_{L_{MD}}$$

The lift coefficient for minimum required power is higher (1.732 times) than that for minimum drag conditions.

Knowing the lift coefficient for minimum required power it is easy to find the speed at which this will occur.

$$V_{MP} = \sqrt{\frac{2W}{\rho S C_{L_{MP}}}} = \sqrt{\frac{2W}{\rho S}} \sqrt{\frac{K}{3C_{D0}}}$$

Note that the velocity for minimum required power is lower than that for minimum drag.

$$V_{MP} = \left(\frac{1}{3} \right)^{1/4} V_{MD} = 0.76 V_{MD}$$

The minimum power required and minimum drag velocities can both be found graphically from the power required plot. Minimum power is obviously at the bottom of the curve. Realizing that drag is power divided by velocity and that a line drawn from the origin to any point on the power curve is at an angle to the velocity axis whose tangent is power divided by velocity, then the line which touches the curve with the smallest angle must touch it at the minimum drag condition. From this we can graphically determine the power and velocity at minimum drag and then divide the former by the latter to get the minimum drag. Note that this graphical method works even for nonparabolic drag cases. Since we know that all altitudes give the same minimum drag, all power required curves for the various altitudes will be tangent to this same line with the point of tangency being the minimum drag point.

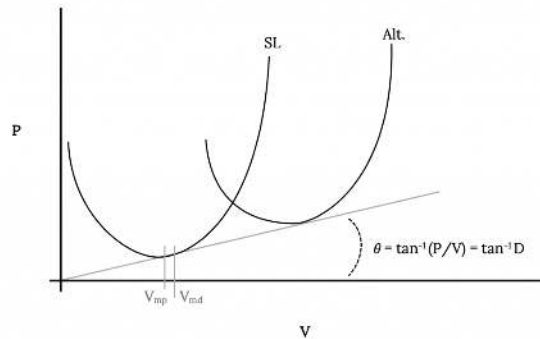

Figure 4.18: Graphical Determination of Minimum Drag and Minimum Power Speeds

One further item to consider in looking at the graphical representation of power required is the condition needed to collapse the data for all altitudes to a single curve. In the case of the thrust required or drag this was accomplished by merely plotting the drag in terms of sea level equivalent velocity. That will not work in this case since the power required curve for each altitude has a different minimum. Plotting all data in terms of V_e would compress the curves with respect to velocity but not with respect to power. The result would be a plot like the following:

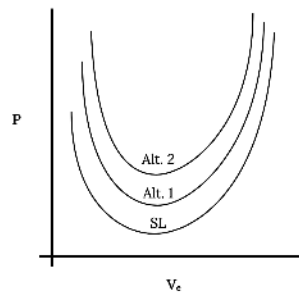

Figure 4.19: Plot of Power Required vs Sea Level Equivalent Speed

Knowing that power required is drag times velocity we can relate the power required at sea level to that at any altitude.

or

$$DV_e = DV \frac{V_e}{V} = DV \sqrt{\sigma}$$

$$P \sqrt{\sigma} = C_{DO} \frac{1}{2} \rho_{SL} S V_e^3 + \frac{2KW^2}{\rho_{SL} S V_e}$$

The result is that in order to collapse all power required data to a single curve we must plot power multiplied by the square root of sigma versus sea level equivalent velocity. This, therefore, will be our convention in plotting power data.

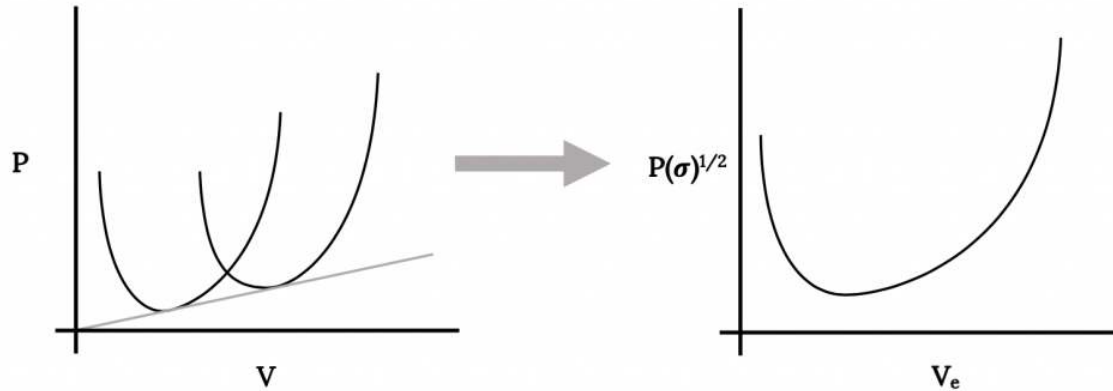

Figure 4.20: Compression of Power Data to a Single Curve

4.17 Review

In the preceding we found the following equations for the determination of minimum power required conditions:

$$P_{R_{\min}} \text{ when } \left(C_D / C_L^{3/2} \right)_{\min}, \text{ when } 3C_{DO} = KC_L^2$$

$$C_{L_{MP}} = \sqrt{\frac{3C_{DO}}{K}} = \sqrt{3}C_{L_{MD}}$$

$$V_{MP} = \sqrt{\frac{2W}{\rho S}} \sqrt{\frac{K}{3C_{DO}}} = 0.76V_{MD}$$

We can also write

$$C_{D_{MP}} = C_{DO} + KC_L^2 = 4C_{DO}$$

$$C_{D_{MP}} = 2C_{D_{MD}}$$

Thus, the drag coefficient for minimum power required conditions is twice that for minimum drag. We also can write

$$(L/D)_{MP} = \frac{C_{L_{MP}}}{C_{D_{MP}}} = \sqrt{\frac{3}{16KC_{DO}}} = 0.866(L/D)_{\max}$$

Since minimum power required conditions are important and will be used later to find other performance parameters it is suggested that the student write the above relationships on a special page in his or her notes for easy reference.

Later we will take a complete look at dealing with the power available. If we know the power available we can, of course, write an equation with power required equated to power available and solve for the maximum and minimum straight and level flight speeds much as we did with the thrust equations. The power equations are, however not as simple as the thrust equations because of their dependence on the cube of the velocity. Often the best solution is an iterative one.

If the power available from an engine is constant (as is usually assumed for a prop engine) the relation equating power available and power required is

$$P = CONST = \frac{1}{2}C_{DO}\rho V^3 S + \frac{2KW^2}{\rho VS}$$

For a jet engine where the thrust is modeled as a constant the equation reduces to that used in the earlier section on Thrust based performance calculations.

EXAMPLE 4.3

For the same 3000 lb airplane used in earlier examples calculate the velocity for minimum power.

$$V_{MP_{SL}} = \sqrt{\frac{2W}{\rho_{SL} S}} \sqrt{\frac{K}{3C_{DO}}} = \sqrt{14430} \sqrt{0.5714}$$

$$V_{MP_{SL}} = 104.44 \text{ ft/sec}$$

- It is suggested that the student make plots of the power required for straight and level flight at sea level and at 10,000 feet altitude and graphically verify the above calculated values.
- It is also suggested that from these plots the student find the speeds for minimum drag and compare them with those found earlier.

4.18 Summary

This chapter has looked at several elements of performance in *straight and level flight*. A simple model for drag variation with velocity was proposed (the parabolic drag polar) and this was used to develop equations for the calculations of minimum drag flight conditions and to find maximum and minimum flight speeds at various altitudes. Graphical methods were also stressed and it should be noted again that these graphical methods will work regardless of the drag model used.

It is strongly suggested that the student get into the habit of sketching a graph of the thrust and or power versus velocity curves as a visualization aid for every problem, even if the solution used is entirely analytical. Such sketches can be a valuable tool in developing a physical feel for the problem and its solution.

Homework 4

1. Use the momentum theorem to find the thrust for a jet engine where the following conditions are known:

inlet velocity	300 fps
inlet flow density	0.0023 sl/ft ³
inlet area	4 ft ²
exit flow velocity	1800 fps
exit flow density	unknown
exit area	2 ft ²
fuel flow rate	5lb _m /sec

Assume steady flow and that the inlet and exit pressures are atmospheric.

2. We found that the thrust from a propeller could be described by the equation $T = T_0 - aV^2$. Based on this equation, describe how you would set up a simple wind tunnel experiment to determine values for T_0 and a for a model airplane engine. Assume you have access to a wind tunnel, a pitot-static tube, a u-tube manometer, and a load cell which will measure thrust. Draw a sketch of your experiment.

References

Figure 4.1: Kindred Grey (2021). “Static Force Balance in Straight and Level Flight.” [CC BY 4.0](#). Adapted from James F. Marchman (2004). https://archive.org/details/4.1_20210804

Figure 4.2: Kindred Grey (2021). “Different Types of Stall.” [CC BY 4.0](#). Adapted from James F. Marchman (2004). https://archive.org/details/4.2_20210804

Figure 4.3: Kindred Grey (2021). “Part of Drag Increases With Velocity Squared.” [CC BY 4.0](#). Adapted from James F. Marchman (2004). https://archive.org/details/4.3_20210804

Figure 4.4: Kindred Grey (2021). “Part of Drag Decreases With Velocity Squared.” [CC BY 4.0](#). Adapted from James F. Marchman (2004). https://archive.org/details/4.4_20210804

Figure 4.5: Kindred Grey (2021). “Total Drag Variation With Velocity.” [CC BY 4.0](#). Adapted from James F. Marchman (2004). https://archive.org/details/4.5_20210804

Figure 4.6: Kindred Grey (2021). “Altitude Effect on Drag Variation.” [CC BY 4.0](#). Adapted from James F. Marchman (2004). https://archive.org/details/4.6_20210804

Figure 4.7: Kindred Grey (2021). “Drag Versus Sea Level Equivalent (Indicated) Velocity.” CC BY 4.0. Adapted from James F. Marchman (2004). CC BY 4.0. Available from https://archive.org/details/4.7_20210804

Figure 4.8: Kindred Grey (2021). “Graphical Method for Determining Minimum Drag Conditions.” CC BY 4.0. Adapted from James F. Marchman (2004). CC BY 4.0. Available from https://archive.org/details/4.8_20210805

Figure 4.9: Kindred Grey (2021). “Thrust and Drag Variation With Velocity.” CC BY 4.0. Adapted from James F. Marchman (2004). CC BY 4.0. Available from https://archive.org/details/4.9_20210805

Figure 4.10: Kindred Grey (2021). “Minimum and Maximum Speeds for Straight & Level Flight.” CC BY 4.0. Adapted from James F. Marchman (2004). CC BY 4.0. Available from https://archive.org/details/4.10_20210805

Figure 4.11: Kindred Grey (2021). “Thrust Variation With Altitude vs Sea Level Equivalent Speed.” CC BY 4.0. Adapted from James F. Marchman (2004). CC BY 4.0. Available from https://archive.org/details/4.11_20210805

Figure 4.12: Kindred Grey (2021). “Straight & Level Flight Speed Envelope With Altitude.” CC BY 4.0. Adapted from James F. Marchman (2004). CC BY 4.0. Available from https://archive.org/details/4.12_20210805

Figure 4.13: Kindred Grey (2021). “True Maximum Airspeed Versus Altitude .” CC BY 4.0. Adapted from James F. Marchman (2004). CC BY 4.0. Available from https://archive.org/details/4.13_20210805

Figure 4.14: Kindred Grey (2021). “Graphical Solution for Constant Thrust at Each Altitude .” CC BY 4.0. Adapted from James F. Marchman (2004). CC BY 4.0. Available from https://archive.org/details/4.14_20210805

Figure 4.15: Kindred Grey (2021). “Power Available Varies Linearly With Velocity.” CC BY 4.0. Adapted from James F. Marchman (2004). CC BY 4.0. Available from https://archive.org/details/4.15_20210805

Figure 4.16: Kindred Grey (2021). “Power Required and Available Variation With Altitude.” CC BY 4.0. Adapted from James F. Marchman (2004). CC BY 4.0. Available from https://archive.org/details/4.16_20210805

Figure 4.17: Kindred Grey (2021). “Power Required Variation With Altitude.” CC BY 4.0. Adapted from James F. Marchman (2004). CC BY 4.0. Available from https://archive.org/details/4.17_20210805

Figure 4.18: Kindred Grey (2021). “Graphical Determination of Minimum Drag and Minimum Power Speeds.” CC BY 4.0. Adapted from James F. Marchman (2004). CC BY 4.0. Available from https://archive.org/details/4.18_20210805

Figure 4.19: Kindred Grey (2021). “Plot of Power Required vs Sea Level Equivalent Speed.” CC BY 4.0. Adapted from James F. Marchman (2004). CC BY 4.0. Available from https://archive.org/details/4.19_20210805

Figure 4.20: Kindred Grey (2021). “Compression of Power Data to a Single Curve.” CC BY 4.0. Adapted from James F. Marchman (2004). CC BY 4.0. Available from https://archive.org/details/4.20_20210805

<!-- pb_fixme --><!-- pb_fixme -->

This page titled [4: Performance in Straight and Level Flight](#) is shared under a [CC BY 4.0](#) license and was authored, remixed, and/or curated by [James F. Marchman](#) ([Virginia Tech Libraries' Open Education Initiative](#)) via [source content](#) that was edited to the style and standards of the LibreTexts platform.

5: Altitude Change - Climb and Guide

Chapter 5. Altitude Change: Climb and Guide

Introduction

Through the basic power and thrust performance curves considered in the last chapter we have been able to investigate the straight and level flight performance of an aircraft. We must now add another dimension to our study of performance, that of changes in altitude. We know that from the straight and level data we can determine the theoretical maximum altitude, or ceiling, for a given aircraft. The question to be answered now is how do we get the aircraft from one altitude to the other? This discussion must include the investigation of possible rates of climb and descent, the distance over the ground needed to climb a given altitude and the range of the aircraft in a glide. How fast can I get from altitude A to altitude B? How far can I glide after my engine fails? If I take off 600 feet from the end of the runway, can I clear the trees ahead?

To look at altitude changes we need to think in terms of energy changes. In climb we are turning kinetic and internal (engine) energy into an increase in potential energy. In a glide we are converting potential energy into velocity (kinetic energy) which will give us needed lift for flight.

One of the questions above involved the rate of climb. In climbing, the aircraft is increasing its potential energy. Rate of climb then involves the change of potential energy in a given time. The engine provides the needed energy for climb and the engine energy output per unit time is power (work per unit time). We are aware that a certain amount of power is required for straight and level flight at a given speed. To climb at that same speed then requires extra power and the amount of that extra power will determine the rate at which climb will occur. The maximum rate of climb at a given speed will then depend on the difference between the power available from the engine at that speed and the power required for straight and level flight. This can be determined from the power performance information studied in the last chapter.

The concept of adding power to increase altitude (climb) is usually not intuitive. Most of us are conditioned by experience with cars, boats and bicycles to think of speed increase as a consequence of adding power. These, of course, are vehicles limited to the altitude of the road or water surface. If we think about a car going over a hill, however, the process is not hard to understand. If a car is traveling at, say, 55 mph (since none of us would think of driving at speeds over the limit!) and we start up a hill holding the accelerator (throttle) steady, the car will decelerate as it climbs the hill, trading kinetic energy for potential energy. To maintain our 55 mph (keeping kinetic energy constant) as we move up the hill we must add power. The same is true in an aircraft.

One of the most difficult things for a flight instructor to teach a new pilot is that the throttle controls the altitude and the control stick or yoke controls the speed. This is, of course, not entirely true since the two controls are used simultaneously; however, this is the analogy that will best serve the pilot in a difficult situation. For example, on an approach to landing the pilot is attempting to hold a steady descent toward the runway. If a sudden downdraft causes a loss of altitude the pilot must take immediate action to regain the lost altitude or run the risk of an unplanned encounter with the ground short of the runway! Pulling back on the control to bring the nose of the aircraft up is the most common instinctive response since the aircraft is descending with the nose down. This will, however, merely increase the angle of attack and result in a reduction in speed, possibly leading to stall and certainly leading to further loss of lift and altitude. The proper response, adding power, will result in a climb to recover from the altitude loss. The ultimate control of the aircraft in such a circumstance will require the coordinated use of both controls to regulate both speed and altitude during this most difficult phase of flight.

The pilot in the above situation is not going to stop think about her or his aircraft's power available or power required performance curves. This is the job of the engineer who designs the airplane to be able to meet the pilot's needs in such a situation. This is our job in the sections that follow. In this study we must add an angle to our previous illustration of the balance of forces on the airplane. This will be the angle of climb, θ , which will be considered positive in a climb and negative in a glide or descent.

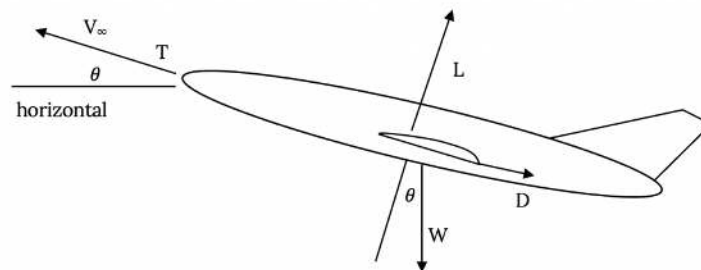

Figure 5.1: Forces in Climb

Summing the forces in the above figure along the thrust axis we find:

$$F = T - D - W \sin \theta = 0$$

But this equation is a static relationship which does not allow acceleration; i.e., does not allow a change in kinetic energy. To consider all the forces which may be involved in climb we must also consider acceleration, so the above equation becomes:

$$F = T - D - W \sin \theta = ma = m(dV/dt)$$

If we rearrange this equation and divide by weight (mg) we get:

$$(T - D)/W = \sin \theta + (1/g)(dV/dt)$$

Then, multiplying by velocity, we have:

$$(TV - DV)/W = V \sin \theta + (V/g)(dV/dt)$$

or

$$(P_{av} - P_{req})/W = V \sin \theta + (V/g)(dV/dt)$$

Now, $V \sin \theta$ turns out to be the vertical velocity or the rate of climb as shown in Figure 5.2.

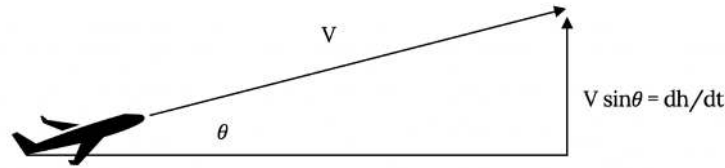

Figure 5.2: Velocity / Rate of Climb Angular Relationship

So we have $(P_{av} - P_{req}) / W = dh/dt + (V/g)(dV/dt)$.

And, we can rearrange this to give

$$dh/dt = (P_{av} - P_{req}) / W - (V/g)(dV/dt).$$

It is common to refer to the first term in parentheses on the right in this equation as the **excess power**. When the excess power is divided by the weight as in the above equation it becomes the **specific excess power, P_s** .

$$P_s = (P_{av} - P_{req}) / W.$$

Now, going back to an earlier form of the equation, we can write

$$P_s = dh/dt + (V/g)(dV/dt)$$

This is a very important relationship which tells us that we can use our excess power (the power over and above that needed for straight and level flight) to either climb (dh/dt) or to change our speed (accelerate or decelerate) or to do both at the same time. We can also convert speed to altitude or altitude into speed.

In real situations a pilot will initiate a climb by both increasing the throttle (adding engine power) and slowing down, meaning that both engine power and kinetic energy are being converted into rate of climb. In descent the pilot will often reduce the plane's power setting (throttle) so that not all of the decrease in potential energy goes into increasing the speed but some goes into the energy needed to maintain lifting flight.

In reality, how much gain can be realized by converting kinetic energy to potential energy without changing the engine power setting? We can find this fairly easily if we look directly at such an exchange

$$\Delta P E = \Delta K E$$

or

$$mg\Delta h = 1/2m(V_1^2 - V_2^2)$$

giving

$$\Delta h = (V_1^2 - V_2^2) / 2g$$

Using this we can find that for an aircraft flying 200 mph and slowing to 160 mph during an initial climb, the altitude gain from swapping kinetic energy for potential energy comes to 483 feet. This is pretty small if one is thinking of making a 5000 ft climb but it may be useful in terms of emergency avoidance maneuvers. On the other hand, the same equation will show that an airplane flying 500 mph can gain over 5000 feet in altitude by slowing to 300 mph and if one is looking at a supersonic speed aircraft this kinetic for potential energy swap becomes very significant in accounting for climb and descent capabilities. Note that the mass of the aircraft is not in the equation above.

In a later chapter we will return to the concepts of specific excess energy and of trading speed for altitude or visa-versa. For the present we will look at the simpler case of un-accelerated flight and assume that all climbs and descents are done at constant speed and that the rate of change of altitude is only a function of the use of excess power. This will essentially assume that the altitude to be gained or lost by changing our airspeed is negligible.

We will start our "static" look at altitude change by looking at gliding flight with zero power available.

5.1 Gliding Flight

The first case we will consider will be the simple case of non-powered descent, or glide. This is a very important performance situation for an aircraft since all aircraft are susceptible to engine failure. One of the first things a student pilot is taught to do is to properly handle an "engine-out" in his or her aircraft; how to set up the best speed to optimize the rate of descent in order to allow maximum time to call for help, restart the engine, prepare for an emergency landing, etc. For some aircraft of course, the unpowered glide is normal. Sailplanes and hang gliders come to mind immediately but one should also consider that the Space Shuttle is nothing but an airplane with an "engine-out" in its descent from orbit to landing!

In an unpowered glide there are only three forces acting on the aircraft, lift, drag and weight. These forces must reach an equilibrium state in the glide. It is up to the pilot to make sure that the equilibrium reached is optimum for survival and, in most aircraft, it is up to the aircraft designer to make the airplane so that it will seek a reasonable equilibrium position on its own. The airplane which stalls and goes into a spin upon loss of an engine will not be very popular with most pilots! We must now determine what those optimum conditions are.

Using Figure 5.1 and using a thrust of zero we can write the following two simple force balance relations in the lift and drag directions:

$$\begin{aligned} L - W \cos \theta &= 0 \\ -D - W \sin \theta &= 0 \end{aligned}$$

Dividing the second equation by the first gives

$$\tan \theta = -D/L = -1/(L/D)$$

There's that term again, **L/D!**

This tells us a very simple and very important fact: **the glide angle depends only on the lift-to-drag ratio.**

The glide angle is:

$$\theta_g = -\delta$$

and

$$\tan \theta_g = 1/(L/D).$$

Something seems wrong here. Does this mean that glide angle has nothing to do with the weight of the aircraft? It sure seems like a heavy airplane wouldn't glide like a light one. Will a Boeing 747 glide just like a Cessna 152? What about the Space Shuttle?

Yes, the equation doesn't contain the weight of the aircraft even though it was in the original force balance equations. The glide angle depends only on the lift-to-drag ratio and that ratio depends on parameters such as C_{D0} , K and e as discussed in the last chapter.

But doesn't the fact that there must be sufficient lift to support the weight (or at least most of it) mean that weight really is a factor? Not really, since drag is also seen to be a function of weight and in the ratio of lift-to-drag, the weight "divides out" of the relationship. A Boeing 747 can indeed glide as well as a Cessna 152.

So, what are our concerns in a glide? Essentially we want to know how far the aircraft can glide (range) and how long will it take to reach the ground (endurance).

5.1.1 Range in a Glide

We will look at the range assuming an absence of any natural wind. This is, of course, rarely the case in real life but is the easiest case for us to examine. We will also assume a steady glide, meaning that the pilot has set (or trimmed) the aircraft such that it will hold the selected indicated airspeed and angle of glide during the entire descent. The geometry of the situation is rather simple as shown below.

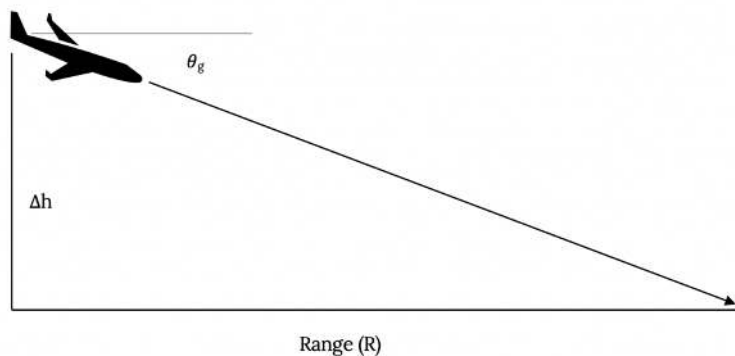

Figure 5.3: Range in a Glide

From the figure it is clear that the glide angle is the arc-tangent of the change in altitude divided by the range.

$$\tan \theta_g = \Delta h / R$$

This gives a range of:

$$R = \Delta h / \tan \theta_g$$

and since the tangent of the glide angle is simply the lift-to-drag ratio we have

$$R = \Delta h (L/D)$$

Maximum range in a glide occurs at the maximum-to-drag ratio; i.e., at minimum drag conditions! We already know how to find anything we may wish to know about minimum drag conditions so we know how to determine conditions for maximum range in an un-powered glide.

To the pilot this means that he or she must, upon loss of engine power, trim the aircraft to glide at the indicated (sea level equivalent) airspeed for minimum drag, a speed which the engineer has provided in the aircraft owner's handbook, **if maximum range is desired**. The pilot would then fly the aircraft to hold the desired speed in the glide.

Usually, *maximum range* is not the most desirable goal in an "engine-out" situation. The best solution is usually to optimize the time before "ground encounter" (hopefully a landing!). This means going for *minimum rate of descent* rather than maximum range. This is, again, one of those things which may not be intuitive to most people, even to pilots, and there are many cases where planes have crashed as pilots tried unsuccessfully to stretch their range after an engine fails. Wind, which wasn't included in the above calculations, can cut range to zero or can enhance it. Distances are hard to judge from the air. Student pilots are taught that in an "engine-out" situation it is *time* that should be optimized rather than *range*. The pilot needs to know the airspeed for minimum rate of descent rather than for maximum range in order to trim the aircraft for a descent which will allow the maximum time to try to restart the engine, to prepare for an emergency landing, to radio for help, etc. This means we are interested in the rate of descent.

Looking at rate of descent is a little more complicated than looking at range. We will consider two cases, the small glide angle case where we can make some simplifying assumptions and the general or large angle case. In looking at the small angle case we will use the usual mathematical assumption that the cosine of an angle is close enough to unity that we can approximate it as one. The usual limit of this assumption is about 5 degrees since a check on our calculator will show that $\cos 5^\circ = 0.99619$. However, our angle of interest is the glide angle which we already know is equal to the arc-tangent of D/L . We would also like to assume that the sine of that angle is approximately equal to its tangent. Because of this we will stretch the applicability of the small angle rationalization to include glide angles up to about 15 degrees.

(At fifteen degrees the cosine is 0.9659, so we are still within 5% of our goal of cosine = 1.0. This is usually pretty good in the real world. Also the tangent of fifteen degrees is 0.2679 while the sine is 0.2588, making our sine = tangent assumption good with less than 4% error.)

A useful result of the small angle assumption is that it will allow us to further assume that lift is approximately equal to weight. Since we had

$$L - W \cos \theta = 0$$

and if

$$\cos \theta \approx 1$$

then

$$L \approx W$$

This might be referred to as "quasi-level" flight. The main advantage of this assumption is that it allows us to continue to relate velocity to weight through

$$L \approx \sqrt{2W} / (\rho S C_L)$$

even though flight isn't really straight and level.

Now we want to begin to look at rate of change of altitude, dh/dt or h . **This is the rate of climb when defined in terms of a positive change of altitude as was shown in Figure 5.2.**

From Figure 5.2 we see that the rate of climb is equal to the plane's airspeed multiplied by the sine of the angle of climb. Referring to our earlier force balance equations for the glide case (no thrust) we can write

$$-D - W \sin \theta = 0$$

or

$$\sin \theta = -D/W$$

and using the small angle assumption that weight is approximately equal to lift gives

$$dh/dt = V \sin \theta = -VD/W \approx -VD/L$$

Changing to a form which uses the force coefficients

$$dh/dt = -V(C_D/C_L)$$

Now use the other small angle assumption for velocity

$$V \approx [2W/(\rho S C_L)]^{1/2}$$

we have

$$dh/dt \approx [2W/(\rho S C_L)]^{1/2} (C_D/C_L)$$

or finally

$$dh/dt \approx [2W/(\rho S)]^{1/2} [C_D/C_L^{3/2}]$$

Note that this is a negative rate of climb since we are looking at the case of glide or descent (we assumed no thrust).

From the above it is obvious that for the minimum rate of descent for a given aircraft and altitude will occur when $C_D/C_L^{3/2}$ is at a minimum. Looking back at our study of power in the previous chapter we find that this is the **same condition found for minimum power required**.

In review, we have found the conditions needed for flight in an un-powered glide for two optimum cases, minimum rate of descent and maximum range with no wind. These are found to occur when the descending aircraft is trimmed to hold an indicated airspeed for minimum power required conditions and for minimum drag, respectively. We know everything about both of these conditions from the previous chapter's discussion.

We have found that for any glide, the range with no wind is

$$R = (L/D)\Delta h = (C_L/C_D)\Delta h$$

and for glide angles of fifteen degrees or less the rate of descent is

$$dh/dt \approx [2W/(\rho S)]^{1/2} [C_D/C_L^{3/2}]$$

These can be used to find the range and rate of descent for any glide condition where we know the appropriate lift and drag coefficients (angle of attack) and are not limited to the optimum cases. In addition, we know that to *optimize range* we need to fly at minimum drag conditions while for a *minimum rate of descent*, we need to fly at the conditions for minimum power required.

Most aircraft in a glide will satisfy the fifteen degree small angle assumption used in the above. A few, such as the Space Shuttle, will not. It is therefore worthwhile to back up and briefly consider the case of steep glide angles. This is, of course, the general case without the small angle assumption. We must use the force balance equations as developed without the approximations. These become

$$L = W \cos \theta$$

and

$$D = -W \sin \theta$$

The velocity equation cannot assume straight and level flight and the first of the above two equations must be used to insert aircraft weight into the relationship.

$$V = \sqrt{2W/\rho S C_L} \cos \theta = L$$

or

$$V = [2W/\rho S C_L]^{1/2} [\cos \theta]^{1/2}$$

The glide angle definition is unchanged

$$\tan \theta = -D/L = -C_D/C_L$$

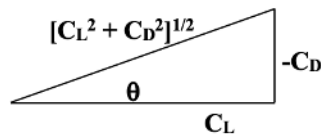

Figure 5.4 Decomposition of Lift and Drag Coefficients

and we can use this relation with some simple trigonometry to find a relationship between the cosine of the glide or climb angle and the lift and drag coefficients.

$$\sin \theta = -C_D/[C_L^2 + C_D^2]^{1/2}, \cos \theta = C_L/[C_L^2 + C_D^2]^{1/2}$$

The rate of climb (rate of descent) equation now becomes

$$dh/dt = V \sin \theta = [2W/(\rho S C_L)]^{1/2} [\cos \theta]^{1/2} \sin \theta$$

or

$$dh/dt = [2W/(\rho S C_L)]^{1/2} \{C_D/[C_L^2 + C_D^2]^{3/2}\}$$

This is a relation which will determine the rate of descent for any glide angle. It is noted that this equation is not really any more complicated mathematically than that found using the small glide angle approximation. The difference is that there is now no correlation between the minimum rate of descent and the condition for minimum power required.

5.2 Time to Descend

Using the rate of descent and the altitude change

$$dh/dt \text{ or } h'$$

it is possible to determine the time required for that descent.

$$dt = dh / (dh/dt)$$

If the rate of descent is constant this can become

$$t = \Delta h / (dh/dt)$$

In reality we have already shown that for both the general and the small angle cases the rate of descent is not constant but depends on altitude since it is a function of density. The complete equation would therefore be

$$t = - \int_{h_1}^{h_2} \frac{dh}{\sqrt{\frac{2W}{\rho S} \left[\frac{C_D}{(C_L^2 + C_D^2)^{3/4}} \right]}}$$

and by using the equations for density variation in the standard atmosphere one could insert density as a function of **h** to give a general equation for time of descent. However, to get a simpler picture of the time to descend problem we will assume that an incremental approach can be used where the density, and thus rate of descent, can be assumed constant over reasonably small increments of altitude during descent. For example, over an increment of altitude of 1000 feet we can base our calculations on the density (rate of descent) half-way between the upper and lower altitude without introducing much error. This can be repeated incrementally to find the time of descent over larger altitude changes. A few simple examples might help illustrate this process.

EXAMPLE 5.1

A sailplane weighs one-thousand pounds and has a wing loading (W/S) of 12.5 pounds per square foot with a drag polar given by

$$C_D = 0.010 + 0.022C_L^2$$

Find the time to glide from 1000 feet to sea level at minimum rate of descent (minimum sink rate).

Solution: Minimum sink rate occurs at conditions for minimum power required

$$C_{L_{opt}} = \sqrt{\frac{3C_{D0}}{K}} = 1.17, C_{D_{opt}} = 4C_{L_{opt}} = 0.04$$

We can check the resulting lift-to-drag ratio to determine if the small angle approximations are valid

$$(L/D)_{opt} = \frac{1.17}{0.04} = 29.2, \theta = \tan^{-1} \left(\frac{1}{L/D} \right) = 1.96^\circ$$

Thus we can find the velocity from the “quasi-level” equation

$$V_{opt} = \sqrt{\frac{2W}{\rho S C_L}}$$

and using the density for a 500 foot altitude we have

$$\rho_{500} = 0.002343 \text{ sl/ft}^3, V_{opt} = 95.5 \text{ fps}$$

and the rate of descent becomes

$$h^{\cdot} = dh/dt = V \sin \theta = -3.27 \text{ fps}$$

giving a time to descend the 1000 feet

$$t = \Delta h / dh/dt = 306 \text{ sec}$$

EXAMPLE 5.2

Consider descent of the same sailplane from a much higher altitude. We can use a descent from 20,000 feet to investigate the inaccuracies of using the incremental approach to the time to descend problem. Suppose that in order to get a first guess for the time to descend we assumed a single increment using the density at 10,000 feet. We will first find an airspeed

$$V_{10k} = \sqrt{\frac{2W}{\rho S C_L}} = 110.27 \text{ fps}$$

then a rate of descent

$$h^{\cdot} = dh/dt = V \sin \theta = -3.771 \text{ fps}$$

giving a time for descent of

$$t = \frac{-20,000 \text{ ft}}{-3.771 \text{ fps}} = 5303 \text{ sec} = 88.4 \text{ min}$$

We should expect improved accuracy if we use four increments of 5000 feet each, calculating velocities and rates of descent at 17,500; 12,500; 7,500; and 2,500 foot altitudes as shown in the following table.

Table 5.1: Example 2

h(ft)	h(mean)(ft)	σ	V(fps)	dh/dt= $V \sin \theta$ (fps)
20,000-15,000	17,500	0.5793	124.49	4.258
15,000-10,000	12,500	0.6820	114.74	3.924
10,000-5,000	7,500	0.7982	106.05	33.627
5,000-SEA LEVEL	2,500	0.9288	98.32	3.363

$$V_{SL} = 94.752 \text{ f}$$

The total time to descend is found by summing the incremental times from each of the 5000 foot descents.

$$t = \left(\frac{\Delta h}{h^{\cdot}} \right)_{20-15} + \left(\frac{\Delta h}{h^{\cdot}} \right)_{15-10} + \left(\frac{\Delta h}{h^{\cdot}} \right)_{10-5} + \left(\frac{\Delta h}{h^{\cdot}} \right)_{5-0}$$

giving $t = 5313.8 \text{ sec} = 88.6 \text{ min}$

This gives a time to descend from 20,000 feet of 88.6 minutes, a difference of only 0.2 minutes or 10.8 seconds from the gross, single increment solution.

Does the above show that there is little point in breaking the glide into increments to find the time of descent or simply that the increments chosen were too large to make much difference? A solution of the “exact” integral equation for the 20,000 foot descent will result in a time of descent of 5426.5 seconds or 90.4 minutes. There is only a two minute difference between the “exact” solution and the worst possible approximation; a 2% error!

5.3 Climbing Flight

As discussed earlier, the addition of power above that required for straight and level flight at a given speed will make possible either an increase in altitude or a change in speed or both. If speed is held constant while power (or thrust) is added the result will be a climb. Since climb is best thought of as an increase in potential energy we can best analyse it on an energy usage basis as reflected in power or energy addition per unit time. To begin our look at climb we can return to the figure used earlier and again write force balance equations in the lift and drag directions, this time adding the thrust vector.

$$L - W \cos \theta = 0$$

$$T - D - W \sin \theta = 0$$

It should be emphasized that we are assuming that climb occurs at constant speed. This means physically that climb is a straight exchange of energy from the engine for a gain in potential energy. It also means that our force balance equations sum to zero; ie, are static equations with no acceleration. We will not, however, restrict ourselves too much. As every good engineer should we will fudge a little by saying that we are flying at "quasi-steady" conditions and tolerate very small accelerations which are inevitable in real flight.

The rate of climb relation is still

$$h' = dh/dt = V \sin \theta$$

From the Thrust/Drag force balance above we can write the angle of climb

$$\sin \theta = (T - D)/W$$

The rate of climb is then

$$h' = \left(\frac{T - D}{W} \right) V = \frac{P_{av} - P_{req}}{W}$$

Note from the above that the angle of climb depends on the amount of excess thrust while the rate of climb depends on the amount of excess power. Not surprisingly, this is the same kind of dependence we found in the gliding case except there we spoke of drag instead of thrust.

Since the angle of climb and rate of climb both can be directly related to previously discussed performance curves for an aircraft, we can take a look at these parameters as they relate to these graphs. A typical plot of thrust and drag (thrust required) is shown below. At any given velocity the difference between the thrust and drag curves can be divided by the aircraft weight to determine the maximum possible angle of climb at that speed using the relationship defined earlier. Of course, at any given speed, not all of the excess available thrust need be used for climb if a lower angle of climb is desired. As the thrust and drag curves move together to the left and right, the possible angle of climb narrows toward zero at the velocities where thrust equals drag.

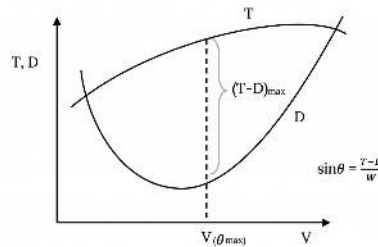

Figure 5.5: Thrust and Drag Influence on Climb

The velocity where the maximum possible angle of climb occurs is that for which the vertical distance between the thrust and drag curves is maximum. This could be found from an actual data plot by simply using a ruler or a pair of dividers to find this maximum. It could also be found analytically if functional relationships are known for the thrust and drag curves by taking the derivative of the difference in thrust and drag with respect to the velocity and setting that equal to zero to determine the maximum.

5.3.1 Case when Thrust is Constant

A simple case occurs when it can be assumed that the thrust available from an engine is constant, an assumption often made for jet engines. If the thrust is constant the maximum difference between thrust and drag and, hence, the maximum angle of climb, must occur when the drag is minimum. Once again minimum drag conditions become the optimum for a performance parameter. It should also be obvious that when thrust is not a constant, minimum drag is probably not the condition needed for maximum angle of climb.

The reader should note that no reference has been made in the above to a parabolic drag polar and the conclusions reached are not restricted to such a case. In the case of the parabolic drag polar we know how to determine the lift and drag coefficients and the speed for minimum drag from our previous study.

A typical plot of power versus velocity is shown below. We know from above that the rate of climb is equal to the difference in the power available and that required, at a given speed, divided by the aircraft weight. Thus the power available / power required graph can be used to graphically determine the rate of climb at any speed in the same manner as the thrust curves were used above. In cases where the power available is assumed constant, as is often the case in a simple representation of a propeller powered aircraft, the maximum rate of climb will occur at the speed where power required is a minimum. We know from the previous chapter how to determine the conditions for minimum power required. If power available is not constant, maximum rate of climb will not necessarily occur at the speed for minimum power required.

Note that the graph shown below plots P/σ versus V_e since this allows the power required data at all altitudes to collapse to a single curve as derived in Chapter 4.

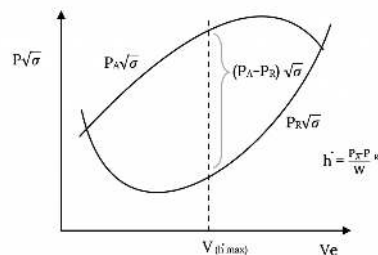

Figure 5.6: Climb Capability on Power Graphs

It should also be noted that maximum rate of climb and maximum angle of climb do not occur at the same speed.

It is interesting to compare the power performance curves, and hence the rate of climb, for the two simple models we have chosen for jet and prop aircraft. In the plot which follows, the prop aircraft is assumed to have constant power available and the jet to have constant thrust. Since power available equals thrust multiplied by velocity, the jet power available data lies in a diagonal line starting at the origin. The power required curve assumes a common aircraft. In other words this is a comparison of the same airplane with two different types of engine. It is obvious that at lower speeds the

rate of climb for the prop exceeds that for the jet while at higher speeds the jet can outclimb the prop. This comparison, while fictional, is typical of the differences between similar jet and prop aircraft. It shows one reason why one would not design a jet powered crop duster since such an aircraft needs a high rate of climb at very low speeds.

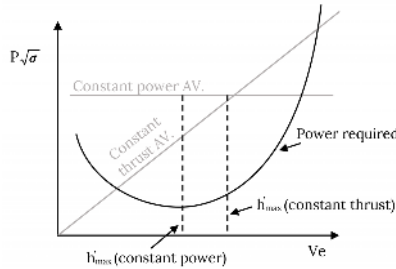

Figure 5.7: Comparison of Constant Power and Constant Thrust Available Cases

5.3.1.1 Special Case: Constant Thrust

In the case mentioned above as a simple model for a jet aircraft, finding the maximum angle of climb is easy since it must occur at the speed for minimum drag or maximum lift-to-drag ratio. The conditions for maximum rate of climb are not as simple. Looking at rate of climb again we recall

$$h^{\circ} = V \sin \theta$$

and assuming quasi-level flight we can write

$$V = \sqrt{\frac{2W}{\rho S C_L}}$$

Thus, we have a relationship which has the lift coefficient as the variable.

$$dh/dt = \left(\frac{2W}{\rho S C_L}\right)^{1/2} \left(\frac{T-D}{W}\right) = C_L^{-1/2} \left(\frac{2W}{\rho S}\right)^{1/2} \left(\frac{T-D}{W}\right)$$

Again rising the quasi-level assumption which assumes that lift is essentially equal to weight

$$D/W = D/L = C_D/C_L$$

We now have a relation which includes both lift and drag coefficients as variables.

However, we know that drag coefficient depends on the lift coefficient in the drag polar.

This gives

$$dh/dt = (2W/\rho S)^{1/2} \left\{ \left(TC_L^{-1/2}/W \right) - \left(C_D/C_L^{3/2} \right) \right\}$$

or

$$dh/dt = (2W/\rho S)^{1/2} \left\{ \left(TC_L^{-1/2}/W \right) - \left(C_{D0} + KC_L^2 \right) / C_L^{3/2} \right\}$$

The above equation is for the constant thrust case and shows the rate of climb as a function of only one variable, the lift coefficient. To determine the optimum rate of climb it is then necessary to take the derivative of this equation with respect to the lift coefficient. Only the terms in the brackets need be included in the derivative since it will be set equal to zero.

$$\frac{d}{dC_L} \left[\frac{T}{W} C_L^{-1/2} - \frac{C_{D0} + KC_L^2}{C_L^{3/2}} \right] = 0$$

This gives

$$KC_L^2 + \frac{T}{W} C_L - 3C_{D0} = 0$$

which can be solved via the quadratic equation to find the value of the lift coefficient which will give the highest rate of climb for this special case of constant thrust.

$$C_{L_{max}} = \frac{-\frac{T}{W} \pm \sqrt{\left(\frac{T}{W}\right)^2 + 12C_{D0}K}}{2K}, \quad T = \text{CONST}$$

EXAMPLE 5.3

A given aircraft has $C_{D0}=0.013$, $K = 0.157$, $W = 35,000$ lb, $S = 530$ sqft, $T/W = 0.429$ and thrust is constant with speed. Find the best rate of climb and the associated angle of climb.

Before starting our solution we should make sure we understand what is being asked. Note that the best angle of climb was not requested. The angle of climb sought was that for the best rate of climb case. Students sometimes assume that the answer sought is always for some optimum case.

To find the maximum rate of climb we use the relation found above to solve for the lift coefficient.

$$C_L = \frac{-0.429 \pm \sqrt{(0.429)^2 + 12(0.013)(0.157)}}{2(0.157)} = 0.088$$

This can then be used to find the associated speed of flight for maximum rate of climb.

$$V_c = \sqrt{\frac{2W}{\rho S C_L}} = 794.1 \text{fps}$$

The angle of climb for maximum rate of climb (not maximum angle of climb) can then be found as follows:

$$\begin{aligned} \sin \theta &= \frac{T-D}{W} = \frac{T}{W} - C_D/C_L \\ &= 0.429 - \frac{0.013 + 0.157(0.088)^2}{0.088} = 0.267 \end{aligned}$$

$$\theta = 15.51^\circ$$

Finally, these are used together to find the rate of climb itself.

$$h^{\circ} = 794.1 \text{fps}(0.267) = 212.4 \text{fps} = 12,743 \text{ft/min}$$

Note: units of feet per minute are traditional.

Now let's look at the other optimum, that of maximum angle of climb for this same aircraft. Maximum angle of climb occurs at conditions for minimum drag or maximum L/D.

$$(\sin \theta)_{max} = \left(\frac{T}{W} - \frac{C_D}{C_L} \right)_{min} = \frac{T}{W} - \frac{1}{0.101_{max}}$$

$$(L/D)_{max} = \frac{1}{\sum_{i=1}^n k C_{Di}^2} = 11.067$$

$$(\sin \theta)_{max} = 0.429 - \frac{1}{11.067} = 0.3386$$

$$\theta_{max} = 19.79^\circ$$

We can then find the lift coefficient associated with maximum angle of climb and the airspeed at which that occurs.

$$C_{L_{max}} = \sqrt{\frac{C_{D_{max}}}{k}} = 0.288$$

$$V_a = \sqrt{\frac{2W}{\rho S C_{L_{max}}}} = 438.96 \text{ fps}$$

Finally, the rate of climb for the maximum angle of climb

$$h' = V \sin \theta = 148.64 \text{ fps} = 8918 \text{ ft/min}$$

Lets look at the answers above and make sure they are logical.

- The maximum rate of climb should be higher than the rate of climb for maximum angle of climb. Is that true?
- The climb angle for the maximum rate of climb case should be less than the maximum angle of climb. Is that true?
- Maximum angle of climb should occur at a lower airspeed than that for maximum rate of climb. Is that the case?

In all cases the above questions are satisfied. These are some of the questions that the student should ask in reviewing the solutions to a problem. Often asking questions such as these can catch errors which might otherwise be ignored.

One situation in which all pilots are interested in both rate of climb and angle of climb is on takeoff. In a normal takeoff the pilot wants to initially climb at the speed which will give the maximum rate of climb. This will allow the aircraft to gain altitude in as short a time as possible, an important goal as a precaution against engine or other problems in takeoff. Should an engine fail on takeoff, maximum altitude is desired to allow time to recover and make an emergency landing. There are, however, some situations in which it is in the pilot's best interest to forgo best rate of climb and go for best angle of climb. An obvious case is when the aircraft must clear an obstacle at the end of the runway such as a tree or tower. The figure below illustrates both cases.

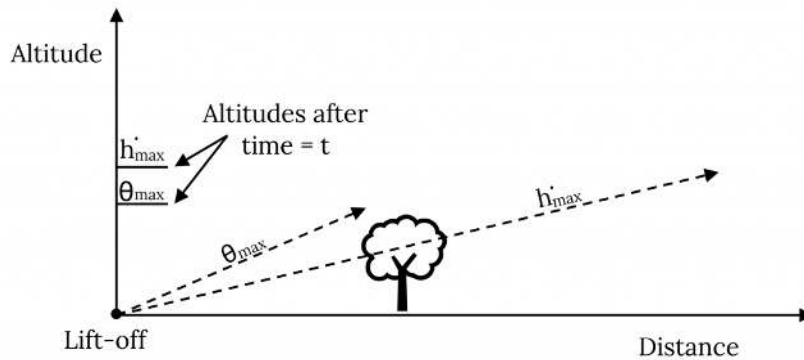

Figure 5.8: Climb Maxima on Take-Off

The airplane which flew at maximum rate of climb would have reached the desired altitude faster than the plane which flew at maximum angle of climb if that darn tree hadn't been in the way!

5.4 Time to Climb

To find the time to climb from one altitude to another we must integrate over the time differential

$$\int_{t_1}^{t_2} dt = \int_{h_1}^{h_2} \frac{dh}{h'} = \int_{h_1}^{h_2} \frac{dh}{V \sin \theta}$$

To integrate this expression we must know how $V \sin \theta$ varies as a function of altitude. We are usually going to be interested in the minimum time to climb as a limiting case. This will, of course, occur at the speed for maximum rate of climb. This speed will be a function of altitude.

If we can find the rate of climb at each altitude we can plot rate of climb versus altitude as shown below. The area under the curve between the two desired altitudes represents the time to climb between those two altitudes.

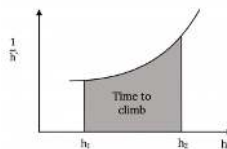

Figure 5.9: Integrating to get Time to Climb

Either of the above methods can be used to find the time to climb. In reality they are the same. The analytical method may not be as simple as it appears at first since the equations must account for the velocity and climb angle variation with altitude, necessitating the incorporation of the standard altitude density equations into the integral. The equations could be simplified by the assumption of a constant velocity climb or a constant angle climb.

5.5 Power Variation with Altitude

We dealt earlier with the variation of **power required** (to overcome drag) with altitude and how the power required curves could be merged into one by plotting power multiplied by the square root of the density ratio. The **power available** must also be multiplied by the square root of the density ratio to be included on the same performance plot. In addition to this we must be aware of how the power available actually varies with altitude.

For both jet engines (turbojet, fan-jet and turbo-prop) and piston engines the power produced by the engine drops in proportion to the decrease in density with increased altitude.

$$P_{av} \propto \rho, \quad P_{alt} = P_{SL} (\rho_{alt} / \rho_{SL})$$

For a **turbocharged** piston engine the turbocharger is designed to maintain sea level intake conditions up to some design altitude. A simple model of power variation with altitude for a turbocharged engine will have **power constant at its sea level value up to about 20,000 feet** and dropping in direct proportion to decreasing density at higher altitudes.

$$P_{AV} = [CONST]_{SL}^{20,000} P_{A>20K} = P_{20K} \frac{\rho_{ALT}}{\rho_{20K}} \quad P_{20K} = P_{20K} \rho_{ALT} / \rho_{20K}$$

More complicated situations are possible with multiple stages of turbocharging.

It must be remembered that in plotting power data versus the sea level equivalent velocity we must **both** account for the real variation in power available as just discussed **and** multiply that result by the square root of the density ratio to make the power available curves compatible with the power required curves. This is not redundant. The first change is made to account for the real altitude effects and the second for a plotting scheme needed to collapse all power required data to a single curve.

5.6 Ceiling Altitudes

In earlier discussion we spoke of the ceiling altitude as that at which climb was no longer possible. This would be the altitude where the power available curve just touches the power required curve, indicating that the aircraft can fly straight and level at only one speed at that altitude. Here the maximum rate of climb is zero. We define this altitude as the **absolute ceiling**. This definition is, however, somewhat misleading.

Theoretically, based on our previous study, it would take an infinite amount of time to reach the ceiling altitude. One could look at the rate of climb possible for an aircraft which is, say, 500 feet below its absolute ceiling. A very low rate of climb would be found, resulting in a very large amount of time required to climb that last 500 feet to reach the absolute ceiling. Because of this we define a more practical ceiling called the **service ceiling**. The definition of the service ceiling is based on the rate of climb; ie, at what altitude is the maximum rate of climb so low as to make further climb impractical. This is different for jet and piston powered aircraft. For the **piston** aircraft, the **service ceiling** is the altitude at which the rate of climb is 100 feet per minute (or 0.5 meters per second). For the **jet** aircraft, the **service ceiling** is the altitude at which the rate of climb is 500 feet per minute (or 2.5 meters per second).

It should be noted that many fighter and high performance aircraft may, in reality, be able to exceed even their absolute ceiling through the use of energy management approaches. An aircraft may climb to its service ceiling, for example, and then go into a dive, building up excess kinetic energy, and then resume a climb, using both the excess power and the excess kinetic energy to climb to altitudes higher than that found as "absolute". Also, at very high altitude it may be necessary to include orbital dynamics in the consideration for climb and ceiling capabilities.

Homework 5

1. An aircraft weighs 3000 lb and has a 175 ft² wing area, an aspect ratio of 7, and an Oswald Efficiency Factor, e, of 0.95. If C_{D0} is 0.028, plot drag versus velocity for sea level and 10,000 feet altitudes, plotting drag in 20 fps intervals. Also calculate the values of minimum drag and the velocity for minimum drag at both altitudes and compare them with the results on your graph. Use the graph paper provided; do not plot by computer.

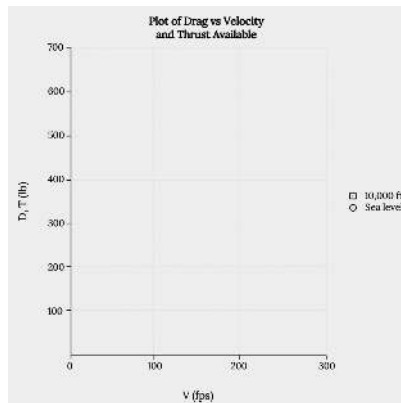

Figure 5.10: Plot of Drag vs Velocity and Thrust Available

2. Using a sea level value of thrust of 400 lb and assuming that thrust is constant with velocity but varies with density (altitude), calculate the maximum and minimum true airspeeds at sea level and at 10,000 ft altitudes and confirm these answers graphically.

References

Figure 5.1: Kindred Grey (2021). "Forces in Climb." [CC BY 4.0](https://archive.org/details/5.1_20210805). Adapted from James F. Marchman (2004). [CC BY 4.0](https://archive.org/details/5.1_20210805). Available from https://archive.org/details/5.1_20210805

Figure 5.2: Kindred Grey (2021). "Velocity/Rate of Climb Angular Relationship." [CC BY 4.0](https://archive.org/details/5.2_20210805). Plane by Bayu Ardhy from the Noun Project. Public domain. Adapted from James F. Marchman (2004). [CC BY 4.0](https://archive.org/details/5.2_20210805). Available from https://archive.org/details/5.2_20210805

Figure 5.3: Kindred Grey (2021). "Range in a Glide." [CC BY 4.0](https://archive.org/details/5.3_20210805). Plane by Bayu Ardhy from the Noun Project. Public domain. Adapted from James F. Marchman (2004). [CC BY 4.0](https://archive.org/details/5.3_20210805). Available from https://archive.org/details/5.3_20210805

Figure 5.4: James F. Marchman (2004). "Decomposition of Lift and Drag Coefficients." [CC BY 4.0](https://archive.org/details/5.4_20210805).

Figure 5.5: Kindred Grey (2021). "Thrust and Drag Influence on Climb." [CC BY 4.0](https://archive.org/details/5.5-new). Adapted from James F. Marchman (2004). [CC BY 4.0](https://archive.org/details/5.5-new). Available from <https://archive.org/details/5.5-new>

Figure 5.6: Kindred Grey (2021). "Climb Capability on Power Graphs." [CC BY 4.0](https://archive.org/details/5.6-new). Adapted from James F. Marchman (2004). [CC BY 4.0](https://archive.org/details/5.6-new). Available from <https://archive.org/details/5.6-new>

Figure 5.7: Kindred Grey (2021). "Comparison of Constant Power and Constant Thrust Available Cases." [CC BY 4.0](https://archive.org/details/5.7_20210805). Adapted from James F. Marchman (2004). [CC BY 4.0](https://archive.org/details/5.7_20210805). Available from https://archive.org/details/5.7_20210805

Figure 5.8: Kindred Grey (2021). "Climb Maxima on Take-Off." [CC BY 4.0](https://archive.org/details/5.8_20210805). Tree by Richard from the Noun Project. Public domain. Adapted from James F. Marchman (2004). [CC BY 4.0](https://archive.org/details/5.8_20210805). Available from https://archive.org/details/5.8_20210805

Figure 5.9: Kindred Grey (2021). "Integrating to Get Time to Climb." [CC BY 4.0](https://archive.org/details/5.9_20210805). Adapted from James F. Marchman (2004). [CC BY 4.0](https://archive.org/details/5.9_20210805). Available from https://archive.org/details/5.9_20210805

Figure 5.10: Kindred Grey (2021). "Plot of Drag vs Velocity and Thrust Available." [CC BY 4.0](https://archive.org/details/hw-5_20210805). Adapted from James F. Marchman (2004). [CC BY 4.0](https://archive.org/details/hw-5_20210805). Available from https://archive.org/details/hw-5_20210805

<!-- pb_fixme --><!-- pb_fixme -->

This page titled [5: Altitude Change - Climb and Guide](#) is shared under a [CC BY 4.0](#) license and was authored, remixed, and/or curated by [James F. Marchman \(Virginia Tech Libraries' Open Education Initiative\)](#) via [source content](#) that was edited to the style and standards of the LibreTexts platform.

6: Range and Endurance

Introduction

A Little Background

In the earliest days of powered flight the primary concern was getting the aircraft into the air and back down safely (with safely meaning the ability to limp away after the “landing”). The Wright’s famous first flight was shorter than a football field and even for a couple of years after December of 1903 they were content to circle around the family farm. The Wright’s home built engines couldn’t run for long periods of time and they simply didn’t envision the need or desire for flights over distances of over a few miles. In 1908, however, Scientific American magazine challenged aviation experimenters to produce an aircraft or “aero-plane”^[1] which could fly, in public view, over a distance of one mile! While the Wright’s claimed to be able to make such a flight, their obsession with secrecy as they sought military sales and their egotistical belief that no one else could approach their expertise in aviation led them to ignore the prize offered by Scientific American for the one mile public flight.

It was Glenn Curtiss, a builder of motorcycle engines and holder of numerous world speed records in motorcycle racing, who, in July of 1908, made the first public one-mile flight. Curtiss, who had worked with Alexander Bell and others to develop their own airplanes, made the flight with newspaper reporters watching and with movie cameras recording the flight. Curtiss became the top aviator in America and the Wrights were furious, leading to numerous legal suits as Wilbur and Orville sought to prove in the courts that Curtiss and Bell had infringed on their patents. Curtiss went on to outperform the Wrights and others in aviation meets in America and Europe. The Wright’s subsequent patent suits aimed at reserving for themselves the sole rights to design and build airplanes in the United States stagnated aircraft development in America and shifted the scene of aeronautical progress to Europe where it remained until after World War I.

As aircraft and aviation continued to develop, range and endurance became the primary objective in aircraft design. In war, bombers needed long ranges to reach enemy targets beyond the front lines and by the end of World War I huge bombers had been developed in several countries. After the war, European governments subsidized the conversion of these giants into passenger aircraft. Some larger planes had even been built as passenger carrying vehicles before the conflict. Sikorski’s early designs are good examples. In the United States, however, with little government interest in promoting air travel for the public until the late 1920’s, long range aircraft development was more fantasy than fact. In 1927 Lindberg’s trans-Atlantic flight captured the public’s imagination and interest in long range flight increased. Lindberg’s flight, like that of Curtiss, was prompted by a prize from the printed media, illustrating the role of newspapers and magazines in spurring technological progress.

By the late 1930’s the public began to see flight as a way to travel long distances in short times, national and international airline routes had developed, and planes like the “China Clipper” set standards for range and endurance. World War II forced people and governments to think in global terms leading to wartime development of bombers capable of non-stop flight over thousands of miles and to post-war trans-continental and trans-ocean aircraft. Since 1903 we have seen aircraft ranges go from feet to non-stop circling the globe and durances go from minutes to days!

6.1 Fuel Usage and Weight

In studying range and endurance we must, for the first time in this course, consider fuel usage. In the aircraft of Curtiss and the Wrights, it was not uncommon for the engine to quit from mechanical problems or overheating before the fuel ran out. In today’s aircraft, range and endurance depend on the amount of fuel on board. When the last drop of fuel is gone the plane has reached its limit for range and endurance. One could, of course, include the glide range and endurance after the aircraft runs out of fuel, but an airline that operated that way would attract few passengers!

Fuel usage depends on engine design, throttle settings, altitude and a number of other factors. It is, however, not the purpose of this text to study engine fuel efficiency or the pilot’s use of the throttle. We will assume that we are given an engine with certain specifications for efficiency and fuel use and that the throttle setting is that specified in the aircraft handbook or manual for optimum range or endurance at the chosen altitude. It is assumed that the student will take a separate course on propulsion to study the origins of the figures used here for these parameters.

Our primary concern in fuel usage will be the change in the weight of the aircraft with time. Many of our performance equations used in previous chapters include the aircraft weight. In those chapters we treated weight as a constant. Weight is, in reality,

constant only for the glider or sailplane. For other aircraft the weight is always changing, always decreasing as the fuel is burned. This means that the aerodynamic performance of the airplane changes during the flight. This does not, however, negate the value of the methods used earlier to study cruise and climb. Those calculations will normally be done using the maximum gross weight of the airplane which will lead to a conservative or “worst case” analysis of those performance parameters. We can also use the methods developed earlier to look at the “instantaneous” capabilities of the aircraft at a given weight, realizing that at a later time in flight and at a lower weight, the performance may be different.

In considering range and endurance it is imperative that we consider weight as a variable, changing from maximum gross weight at take-off to an empty fuel tank weight at the end of the flight. To do this we will deal with fuel usage in terms of the weight of the fuel (as opposed to fuel volume, in gallons, which we normally use for automobiles). When our concern is **endurance** we are interested in the change in weight of the fuel per unit time

$$\frac{dW_f}{dt} \quad (6.1)$$

and, when range is the concern we want to know how the weight of fuel decreases with distance traveled.

$$\frac{dW_f}{dS} \quad (6.2)$$

Aircraft engine manufacturers like to specify engine fuel usage in terms of **specific fuel consumption**. For jet engines this becomes a *thrust specific fuel consumption* and for prop aircraft, a *power specific fuel consumption*. Since thrust and power bring different units into the equations we must consider the two cases separately.

6.2 Range and Endurance: Jet

We speak of the engine output of a jet engine in terms of thrust; therefore, we speak of the fuel usage of the jet engine in terms of a **thrust specific fuel consumption, C_t** . C_t is the **mass of fuel consumed per unit time per unit thrust**. The unit of time should be seconds and the unit for thrust should be in pounds or Newtons of thrust.

$$[C_t] = (\text{sl/sec})/\text{lb}_{\text{thrust}}, \text{ or } = (\text{kg/sec})/\text{N}_{\text{thrust}}$$

The above is the proper definition of thrust specific fuel consumption, however, it is not really exactly what we need for our calculations. We would prefer a definition based on **weight** of fuel consumed instead of the **mass**. We will thus define a **weight specific fuel consumption, γ_t** , as the weight of fuel used per unit time per unit thrust. This gives units of $(\text{time})^{-1}$.

$$[\gamma_t = gC_t] = (\text{lb}_{\text{fuel}}/\text{sec})/\text{lb}_{\text{thrust}}, \text{ or } = (\text{N}_{\text{fuel}}/\text{sec})/\text{N}_{\text{thrust}} = (\text{sec})^{-1} \quad (6.3)$$

The reader should be aware that many aircraft performance texts and propulsion texts are very vague regarding the units of specific fuel consumption. Some even define it in terms of mass and give it units of $1/\text{sec}$., making it dimensionally incorrect. Part of the confusion, particularly in older American propulsion texts, lies in the use of the pound-mass as the unit of mass. This gives a combination of pounds-mass divided by pounds-force, which, in reality gives sec^2/ft . The situation is then further complicated by the author seemingly throwing in a term called g_c which is supposed to resolve the lb_m/lb_f issue. At any rate it is very important that the engineer using specific fuel consumption carefully consider the units involved before beginning the solution of a range or endurance problem. A correctly specified **weight specific fuel consumption** will have units of sec^{-1} and will do so without the use of anything called g_c .

It should be added that one might also encounter specific fuel consumption which has been calculated using mass of fuel (kg) and thrust in kilograms, a non-SI unit which is used in much of the world (virtually no one in the world knows what a Newton is or how to use it). If this is done the numerical value should be the same as obtained using the weight specific fuel consumption definition above.

Some sources of specific fuel consumption data use units of $(\text{hours})^{-1}$ since the hour is a more convenient unit of time. The use of seconds is, however, correct in any standard unit system and the student may be well advised to convert hours to seconds before beginning calculation even though this will ultimately result in the calculation of endurance in seconds, giving rather large numbers for answers.

To find endurance we want the rate of fuel weight (W_f) change per unit time which can be written in terms of the thrust specific fuel consumption

$$dW_f/dt = \gamma_t T \quad (6.4)$$

And, in straight and level flight where thrust equals drag

$$dW_f/dt = \gamma_t D \quad (6.5)$$

For maximum endurance we want to minimize the above term. This clearly shows that for **maximum endurance** the **jet** plane must be flown at **minimum drag conditions**. We will look at how to find that endurance after taking a brief look at range.

To find the flight range we must look at the rate of change of fuel weight with distance of flight. We might pause a little at this point to realize that this may be more complicated than endurance because range will depend on more than simply the aerodynamic performance of the airplane. It will also require consideration of the wind speed. An airplane can fly forever at a speed of 100 mph into a 100 mph head-wind and still have a range of zero! For now, however, we will put those worries aside and look at the simple mathematics with which we begin consideration of the problem. We looked above at the rate of weight change with time. We can combine this with the change of distance with time (speed) to get the rate of change of weight with distance.

$$dW_f/dS = (dW_f/dt) / (dS/dt) = \gamma_t (T/V) = \gamma_t (D/V) \quad (6.6)$$

Note that we still assume $D = T$ or straight and level flight.

From the above it is obvious that maximum range will occur when the drag divided by velocity (D/V) is a minimum. This is not a condition which we have studied earlier but we can get some idea of where this occurs by looking at the plot of drag versus velocity for an aircraft.

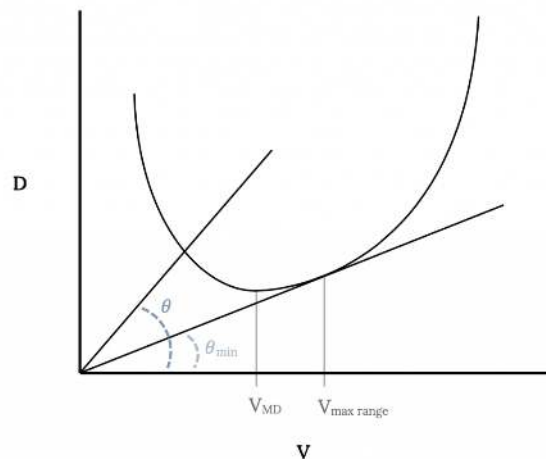

Figure 6.1: Finding Velocity for Maximum Range

On this plot a line drawn from the origin to intersect the drag curve at any point has a tangent equal to the drag at the point of intersection divided by the velocity at that point. The minimum possible value of D/V for the aircraft represented by the drag curve must then be found when the line is just tangent to the drag curve. This point will give the velocity for maximum range. Note that it is a higher speed than that for minimum drag (which, in turn was higher than the speed for minimum power).

In the above we have found the conditions needed to achieve **maximum range and endurance** for a jet aircraft. We have not yet found equations for the actual range or endurance. To find these we need to return to the time and distance differentials and integrate them. For time we have

$$dt = dW_{fuel} / (\gamma_t T)$$

We now wish to put the equations in a form which includes the weight of the aircraft instead of the weight of the fuel. Since the change in weight of the aircraft in flight is equal and opposite the weight of fuel consumed

$$dW = -dW_{fuel}$$

we have

$$dt = -dW / (\gamma_T T)$$

Finally, integrating over time to find the endurance gives

$$E = - \int_{W_1}^{W_2} \frac{dW}{\gamma_T T}$$

In a similar manner the range is found from the distance differential

$$dS = -VdW / (\gamma_T T)$$

or

$$R = - \int_{W_1}^{W_2} \frac{VdW}{\gamma_T T}$$

In the above equations we must know how the aircraft velocity, thrust and specific fuel consumption vary with aircraft weight. At this point we need to make some assumptions about the way the flight is to be conducted. This is sometimes called the “flight schedule”.

6.3 Approximate Solutions for Range and Endurance for a Jet

The first assumption to be made in finding range and endurance equations is that the flight will be essentially straight and level. In order to give ourselves some leeway we will call this “quasi-level” flight, our desire being merely to use the $L = W$. $T = D$ relations.

$$T = D = W(D/L) = W(C_D/C_L),$$

and we can also use

$$V = \sqrt{\frac{2W}{\rho S C_L}}$$

Substituting these into the range and endurance relationships above give

$$E = - \int_{W_1}^{W_2} \frac{dW}{\gamma_T D} = - \int_{W_1}^{W_2} \frac{1}{\gamma_T} \frac{C_L}{C_D} \frac{dW}{W}, R = - \int_{W_1}^{W_2} \frac{1}{\gamma_T} \left(\frac{2}{\rho S}\right)^{1/2} \frac{C_L^{1/2}}{C_D} \frac{dW}{W^{1/2}}$$

At this point we need to make some further assumptions about the flight schedule in order to simplify the integration of these equations. For example, in the endurance equation, if we assume that the flight is made at constant angle of attack, we are assuming that the lift and drag coefficients are constant for the entire flight. If we also assume that the specific fuel consumption is constant for the flight the only variable left in the integral is weight itself and the integral becomes:

$$E = - \frac{1}{\gamma_T} \frac{C_L}{C_D} \int_{W_1}^{W_2} \frac{dW}{W} = \frac{1}{\gamma_T} \frac{C_L}{C_D} \ln \left(\frac{W_1}{W_2} \right)_{(\text{const } \alpha)}$$

The range integral contains an additional variable, the density of the atmosphere. It is still possible to make a couple of combinations of assumptions which will result in simple integration and realistic flight conditions. The first case will be to assume cruise at both constant altitude and constant angle of attack giving both density and the lift and drag coefficients as constants in the integration.

$$R = \frac{2 \cdot \sqrt{2}}{\gamma_T \cdot \sqrt{\rho S}} \frac{C_L^{1/2}}{C_D} (\sqrt{W_1} - \sqrt{W_2})_{(\text{const } \alpha, \text{ const } V)}$$

A second simple case combines the assumptions of constant angle of attack and constant speed, which can be used with the earlier form of the range equation.

$$R = - \int_{W_1}^{W_2} \frac{VdW}{\gamma_T T} = - \int_{W_1}^{W_2} \frac{V}{\gamma_T} \frac{C_L}{C_D} \frac{dW}{W}$$

giving

$$R = \frac{V}{\gamma_T} \frac{C_L}{C_D} \ln \left(\frac{W_1}{W_2} \right) \quad \left(\begin{array}{l} \text{const } \alpha \\ \text{const } V \end{array} \right)$$

Note that the last equation above is simply the endurance equation multiplied by the velocity. This should not be surprising since this is the case where velocity is constant.

In the final equations above for range and endurance we should note that if standard units are used with specific fuel consumptions in sec^{-1} , range will be given in feet or meters and endurance in seconds. We may find it easier to ascertain the degree to which our answers are realistic if we convert these answers to miles or kilometers and hours.

In finding the above equations for range and endurance we have looked only at **special cases** which would result in simple integrations. If we know more complicated flight schedules we can determine the functional relationships between the lift and drag coefficients, velocity, density, etc. and weight loss during flight and insert them into the original integrals to solve for range and endurance. The above cases are, however, very close to actual operational cruise conditions for long range aircraft and will probably suffice for an introductory study of aircraft performance. Let's take a look at those simple cases.

Both range cases included our endurance assumption of constant angle of attack and specific fuel consumption. The first case combined these assumptions with specification of constant altitude. This appears to be the simplest case to actually fly but to see what it actually means we need to go back to the straight and level flight velocity relation

$$V = [2W/(\rho S C_L)]^{1/2}$$

or $V \propto W^{1/2}$, when ρ and C_L are both constant.

If altitude (density) and angle of attack (lift coefficient) are both constant it is obvious that the velocity must change as the weight changes. In other words, *for this flight schedule as fuel is burned and the weight of the aircraft decreases, the flight speed must decrease in proportion to the square root of the weight.*

The other case, constant speed combined with constant angle of attack, is seen from the velocity relation above to require that density decrease in proportion to the weight.

$W/\rho = \text{const. when } V \text{ and } C_L \text{ are constant.}$

This means that *as the aircraft burns off fuel, the aircraft will slowly move to higher altitudes where the density is lower.* This is commonly known as the **drift-up** flight schedule. This is actually very similar to the way that commercial airliners fly long distance routes. Those of you who have been on such flights will recall the pilot announcing that "we are now cruising at 35,000 feet and will climb to 39,000 feet after crossing the Mississippi" or some such plan. While the FAA will not allow aircraft to simply "drift-up" as they fly from coast-to-coast, they will allow schedules which incrementally approximate the drift-up technique.

It must be noted that the two range equations above will give two different answers for the same amount of fuel. Also note that the equations are based on only the cruise portion of the flight. An actual flight will include take-off, climb to cruise altitude, descent and landing in addition to cruise. Allowance also must be made for reserve fuel to handle emergency situations and "holds" imposed by air traffic controllers.

The biggest assumption used in all the integrations above is that of constant angle of attack. While this fits our conditions for optimum cases such as maximum endurance

occurring at maximum lift-to drag ratio (minimum drag), it may not fit real flight very well. While the pilot can easily monitor his or her airspeed and altitude, the airplane's angle of attack is not as easily monitored and directly controlled.

The equations above for range and endurance are valid for any flight condition which falls within the assumptions made in their derivation. If we have a Boeing 747 flying at an angle of attack of eight degrees and a speed of 250 miles per hour these equations can be used to find the range and endurance even though this is obviously not an optimum speed and angle of attack. **Should we wish to determine the optimum range or endurance we must use the values of lift and drag coefficient and the velocity which we found earlier to be needed for these optimums.**

Earlier we found that for maximum endurance the aircraft needs to fly at minimum drag conditions. Our actual endurance equation confirms this, showing endurance as a function of the lift-to-drag coefficient ratio which will be a maximum if drag is a minimum.

We also found that range would be optimum if the drag divided by velocity was a minimum. The correlation between this condition and the range equations derived is not as obvious as that of minimum drag with the endurance equation. Using the straight and level flight force relations which can be manipulated to show

$$D = W[D/L] = W[C_D/C_L]$$

the quantity V/D can be written

$$V/D = [V/W][C_L/C_D] .$$

Now using the velocity relation for straight and level flight

$$v = [2W/(\rho S C_L)]^{1/2}$$

we find

$$V/D = [2W/\rho S]^{1/2} (1/W) (C_L^{1/2}/C_D)$$

Therefore, we find that the maximum range occurs when, for a given weight and altitude

$$C_L^{1/2}/C_D \text{ is a maximum.}$$

If we assume a parabolic drag polar with constant C_{D0} and K we can write

$$C_L^{1/2}/C_D = C_L^{1/2} / [C_{D0} + KC_L^2]$$

To find when this combination of terms is at a maximum we can take its derivative with respect to its variable (C_L) and set it equal to zero.

$$\frac{d}{dC_L} \left(\frac{C_L^{1/2}}{C_D} \right) = \frac{(C_{D0} + KC_L^2)^{-1/2} C_L^{-1/2} - C_L^{1/2} (2KC_L)}{C_D^2} = 0$$

Solving this gives

$$\frac{1}{2}(C_{D0} + KC_L^2)C_L^{-1/2} - (2KC_L^2) / C_L^{1/2} = 0$$

or

$$C_{D0} + KC_L^2 - 4KC_L^2 = 0$$

then

$$C_{D0} = 3KC_L^2$$

and, finally

$$C_L = [C_{D0} / 3K]^{1/2} .$$

Thus, for maximum range

$$C_{L_{\text{MAXR}}} = \sqrt{\frac{C_{D0}}{3K}} .$$

Using this in the drag polar gives the value of drag coefficient for maximum range

$$C_{D_{\text{MAXR}}} = C_{D0} + KC_{L_{\text{MAXR}}}^2 = C_{D0} + KC_{D0}/(3K) = (4/3)C_{D0} .$$

These are referred to as the conditions for “**instantaneous**” maximum range. The term instantaneous is used because the calculations are for a given weight and we know that weight is changing during the flight. In other words, *at any point during the flight, at the weight and altitude at that point, the lift and drag coefficients found above will give the best range.*

6.4 Range and Endurance: Prop

We will now look at range and endurance for propeller driven aircraft in which the engine performance is normally expressed in terms of power instead of thrust. An examination of range and endurance for aircraft which have performance measured in terms of **power** (propeller aircraft) is made by defining a **power specific fuel consumption** similar to the thrust specific fuel consumption

used for jets. The power specific fuel consumption is defined as the **mass of fuel consumed per unit time per unit shaft power**. The units are **slugs per unit power per second in the English system** or **kilogram per unit power per second in SI units**.

$$[C_p] = \text{sl}/(\text{power-sec}) \text{ or } \text{kg}/(\text{power-sec})$$

The power units used are **horsepower** in the English system and **watts** in SI units.

Just as we did in the jet (thrust) case, we will often find an alternate definition of specific fuel consumption given in terms of the weight of fuel consumed instead of the mass.

$$\gamma_p = gC_p \quad [\text{lb}_{\text{fuel}}/\text{hp sec. or } \text{N}_{\text{fuel}}/\text{watt sec.}]$$

While the proper time unit is seconds we will often find such data given for an engine in terms of hours. We will develop our equations in terms of the fundamental units (seconds for time) and, as in the jet case, assume “quasi-level” flight which has

$$P_{\text{avail}} = P_{\text{req}} = DV$$

In dealing with prop engines we must consider the propulsive efficiency, η_p , which relates the **shaft power, P_s** , coming from the engine itself to the power effectively used by the prop to transfer momentum to the air.

$$P_{\text{avail}} = DV = \eta_p P_s$$

As for the jet, to find endurance we must consider

$$dW_f/dt = \gamma_p P_s = \gamma_p DV/\eta_p$$

and for range are interested in

$$dW_f/dS = (dW_f/dt)/(dS/dt) = \gamma_p D/\eta_p$$

From the above equations it is obvious that, for a given specific fuel consumption and efficiency, the rate of fuel use is a minimum (instantaneous endurance is a maximum) when the power required (DV) is a minimum. It is also obvious that the fuel use per amount of distance traveled is a minimum (instantaneous range is a maximum) when the drag is a minimum.

So we again run into our old friends **minimum power required** and **minimum drag** as conditions needed for optimum flight. We already know how to find these graphically from power versus velocity plots as shown below. This graphical determination of minimum power and minimum drag speeds is valid for any drag polar, even if not parabolic.

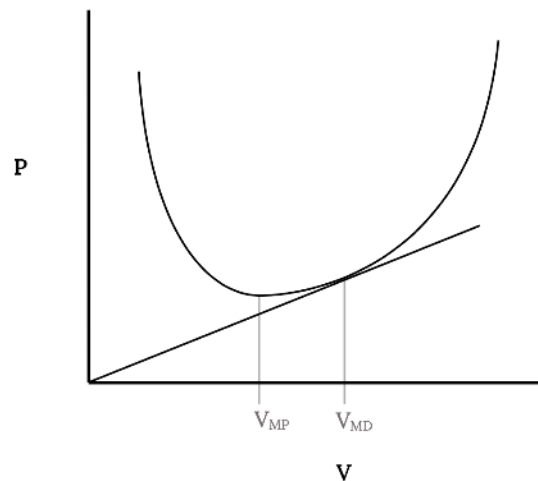

Figure 6.2: Velocities for Minimum Power and Drag

At this point we should pause and say: **“Hey, wait just a minute! It was only a couple of pages back that you said that maximum endurance occurred at minimum drag conditions. Now you say it’s maximum range that I get at minimum drag conditions. Make up your mind, for Pete’s sake!”**

The problem is that in one case we are talking about jets and the other, prop aircraft. **This means that we must be very careful to see which type of plane we are dealing with before starting any calculations.** It is very easy to get into a big rush and get the

two cases mixed up (especially in the heat of battle on a test or exam!).

Now, as we did for the jet, we can develop integrals to determine the range or endurance for any flight situation. For endurance we have

$$E = \int_{t_1}^{t_2} dt = - \int_{W_1}^{W_2} \frac{\eta_p dW}{\gamma_P DV}$$

and for range

$$R = \int_{s_1}^{s_2} dS = - \int_{W_1}^{W_2} \frac{\eta_p dW}{\gamma_P D}$$

6.5 Approximate Solutions for Range and Endurance for a Prop Aircraft

Once more we will assume “quasi-level” flight and manipulate the terms in our force balance relations to give

$$D = W \left[\frac{D}{L} \right] = W \left[\frac{C_D}{C_L} \right] \quad (6.7)$$

This makes the endurance integral

$$E = - \int_{W_1}^{W_2} \frac{\eta_p}{\gamma_P} \frac{1}{V} \frac{C_L}{C_D} \frac{dW}{W} \quad (6.8)$$

Using the straight and level velocity relation

$$V = [2 W / (\rho S C_L)]^{1/2} \quad (6.9)$$

we get

$$E = - \int_{W_1}^{W_2} \frac{\eta_p}{\gamma_P} [\rho S / 2]^{1/2} \frac{C_L^{3/2}}{C_D} \frac{dW}{W^{3/2}} \quad (6.10)$$

The range integral can be written in a similar fashion as

$$R = - \int_{W_1}^{W_2} \frac{\eta_P}{\gamma_P} \frac{C_L}{C_D} \frac{dW}{W} \quad (6.11)$$

Now we need to consider the same flight schedules examined in the jet case. Constant angle of attack flight will give constant lift and drag coefficients and constant altitude will give constant density. We will also assume constant specific fuel consumption.

For range we need only to use the constant angle of attack assumption to give a simple integral. The resulting range is

$$R = \frac{\eta_P}{\gamma_P} \frac{C_L}{C_D} \ln \left(\frac{W_1}{W_2} \right), \quad (\text{const } \alpha) \quad (6.12)$$

For endurance we will consider two cases. The first holds both altitude and angle of attack constant, giving

$$E = - \frac{\eta_P}{\gamma_P} \sqrt{\frac{\rho S}{2}} \frac{C_L^{3/2}}{C_D} \int_{W_1}^{W_2} \frac{dW}{W^{3/2}} \quad (6.13)$$

which integrates to

$$E = \frac{\eta_P}{\gamma_P} \sqrt{2\rho S} \frac{C_L^{3/2}}{C_D} \left(\frac{1}{\sqrt{W_2}} - \frac{1}{\sqrt{W_1}} \right), \quad \left(\begin{array}{l} \text{const } \alpha \\ \text{const } \rho \end{array} \right) \quad (6.14)$$

The second case has angle of attack and velocity constant

$$E = - \frac{\eta_P}{\gamma_P} \frac{1}{V} \frac{C_L}{C_D} \int_{W_1}^{W_2} \frac{dW}{W} \quad (6.15)$$

or

$$E = \frac{\eta_P}{\gamma_P} \frac{1}{V} \frac{C_L}{C_D} \ln \left(\frac{W_1}{W_2} \right), \quad \left(\begin{array}{l} \text{const } \alpha \\ \text{const } V \end{array} \right) \quad (6.16)$$

This is the “drift up” flight schedule.

6.6 Wind Effects

The above range and endurance equations for both jet or prop aircraft were derived assuming no atmospheric winds. The speeds in the equations are the airspeeds, not speeds over the ground. If there is a wind the airspeed is, of course, not equal to the speed over the ground.

Endurance calculations are not altered by the presence of an atmospheric wind. If our concern is how long the aircraft can stay in the air at a given airspeed and altitude and we don’t particularly care if it is making progress over the ground we need not worry about winds. We are doing endurance calculations based only on the aerodynamic behavior of the airplane at a given speed and altitude in a mass of air.

Range is related to speed across the ground rather than the airspeed; thus, if there is a wind our range equation results need to be re-evaluated to account for the wind. The logic of this is simple: a headwind will slow progress over the ground and reduce range while a tailwind will increase range. What is not so obvious is how to correct the calculations to account for this wind. Since our usual concern is to find the **maximum range**, we will examine the correction for wind effects only for this optimum situation.

Maximum range for a jet was found to occur when D/V was a minimum while, for a prop, maximum range occurred at minimum drag conditions. The velocities for both cases can be determined graphically by finding the point of tangency for a line drawn from the zero velocity origin on either the drag versus velocity curve in the jet case or the power required versus velocity curve for the prop plane. We can use an extension of this graphical approach to find the speed for best range with either a head wind or a tail wind.

The important first step in determining optimum range in the presence of an atmospheric wind is to **find a new airspeed for best range with a wind**. This new speed will then be used to calculate a new value of the optimum range. The new value of best range airspeed is found as illustrated in the figures below. The first task is to draw a conventional drag versus velocity (for a jet) or power required versus velocity (for a prop) plot. To this plot is added a **new origin, displaced to the left by the value of a tailwind or to the right by the magnitude of the tailwind**. A line is then drawn from the displaced origin, tangent to the drag or power curve and the point of tangency locates the new velocity for optimum range with a wind. **The magnitude of this new optimum range velocity is read with respect to the original origin** (not the displaced origin). This speed is an airspeed, not a ground speed.

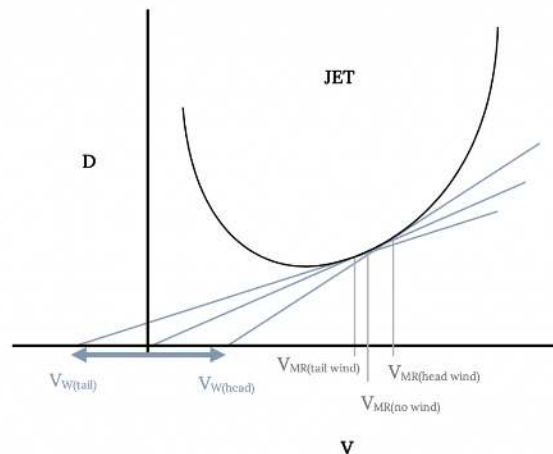

Figure 6.3: Speed for Best Range with Wind (Jet)

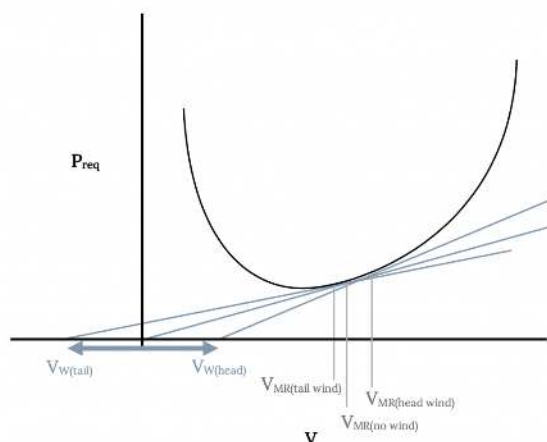

Figure 6.4: Speed for Best Range with Wind (Prop)

This new optimum range velocity is then used to find a new range value from the same equations developed previously. Using the new velocity, new values of lift and drag coefficients are first calculated and these new coefficients and velocity are used to find the optimum range with the wind. To this new range must be added another range which results purely from the aircraft's time of exposure (endurance) to the wind. This endurance is also found using the newly found optimum range velocity and associated coefficients. **The final corrected range for maximum range in a wind is**

$$R_{\text{with wind}} = R_{\text{Corrected}} + V_w E_{\text{Corrected}} \text{ for a tailwind}$$

or

$$R_{\text{with wind}} = R_{\text{Corrected}} - V_w E_{\text{Corrected}} \text{ for a headwind}$$

6.7 Let the Buyer Beware

Airplane manufacturers, like those of automobiles and other products, like to do anything they can to make their product look good and sometimes they hope that the buyer doesn't look too closely at the contradictions in their specifications and advertising. A car may be advertised as having seating for five, an EPA fuel economy rating of 38 mpg, the ability to go 542 miles on a single tank of gas and a top speed of 120 miles per hour. Most of us, however, know not to expect that car to go 542 miles on a single tank of gas while carrying 5 people at a speed of 120 mph! Those who believe it will would also probably be dumb enough to pay sticker price.

What about airplanes? Is this product of an industry which is regulated at every step by the FAA just as subject to contradiction in specifications as a car?

Let's look at a few simple examples taken from a general aviation Aircraft Fleet Directory of a few years back. A Cessna 150, the most widely used two place aircraft in the country, quotes a range of 815 nautical miles on 32 gallons (210 pounds) of fuel. The plane has an empty weight (no pilot, passenger, baggage or fuel) of 1104 pounds and a maximum gross takeoff weight of 1600 pounds. This means that with the full fuel tanks needed for maximum range there is only a 286 pound allowance for both pilot and passenger, hardly enough for two adults and luggage! This is why one of the favorite questions of flight examiners who are preparing for a private pilot check-ride in a Cessna 150 involves weight and balance of the aircraft and why sometimes pilots may have to actually pump fuel out of an airplane before takeoff.

A Cessna 172, the most popular four place aircraft in the world, is a little better than the 150 cited above. It has an empty weight of 1387 pounds and to reach its advertised range of 742 miles it has a fuel tank which holds 288 pounds of gas. This gives a total weight for airplane and fuel of 1675 pounds. The maximum gross takeoff weight of the 172 is 2300 pounds, leaving 625 pounds allowance for four passengers and their stuff; an average of 156 pounds each! It is beginning to look like airplanes are designed like those "four-place" cars which have a rear seat about large enough to seat two small poodles!

With another Cessna product, the all around best of their 4 seat line, the Skylane, things are a little better. Its listed empty weight of 1707 pounds, range of 979 nautical miles on 474 pounds of fuel and max gross weight of 2950 pounds leave 769 pounds for pilot, passengers and accessories (192 pounds each). Finally an airplane for real people!

Lest the naive get the idea that this is only a problem for small single engine airplanes, let's look at one more example, the eight place Learjet 25C. It claims a range of 2472 miles, just the ticket for the rich young business tycoon to fill with seven of her closest friends for a transcontinental weekend jaunt. The listed fuel capacity of 7393 pounds, adds to the quoted "zero fuel" weight of 11,400 pounds to give a 18,793 pound airplane. So how much is left for those 8 passengers? **The listed max gross weight of the Learjet 25C is 15,000 pounds! With a full tank of gas the airplane is over its maximum allowable takeoff weight!** With a 160 pound pilot and no other passengers or payload this airplane can carry enough fuel for a real range of about 1150 miles, less than half that advertised. Why claim a range of almost 2500 miles? Well, the fuel tanks are big enough to carry the needed fuel. If only the airplane could get off the ground!

Homework 6

1. An aircraft weighs 56,000 pounds and has 900ft^2 wing area. Its drag polar equation is given by $C_D = 0.016 + 0.04C_L^2$. The plane has a turbojet engine with constant thrust at any given altitude as shown below:

Table 6.1: Question 1

altitude (ft)	0	5000	10,000	15,000	20,000	25,000	30,000
thrust (lb)	6420	5810	5200	4590	4000	3360	2700

- Find the minimum thrust required for straight and level flight and the corresponding true airspeeds at sea level and at 30,000 ft.
 - Find the minimum power required and the corresponding true airspeeds at sea level and 30,000 ft.
2. For the aircraft above:
- plot thrust and drag vs V_e for straight and level flight.

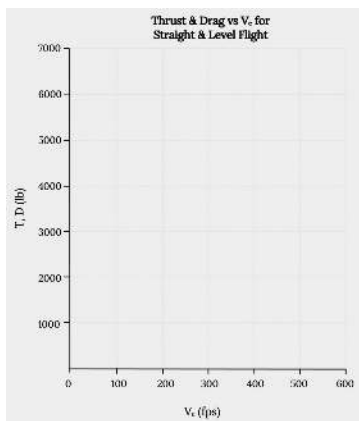

Figure 6.5: Thrust and Drag Versus V_e For Straight and Level Flight

- plot altitude vs $V_{e\max}$ and V_{\max} for straight and level flight.

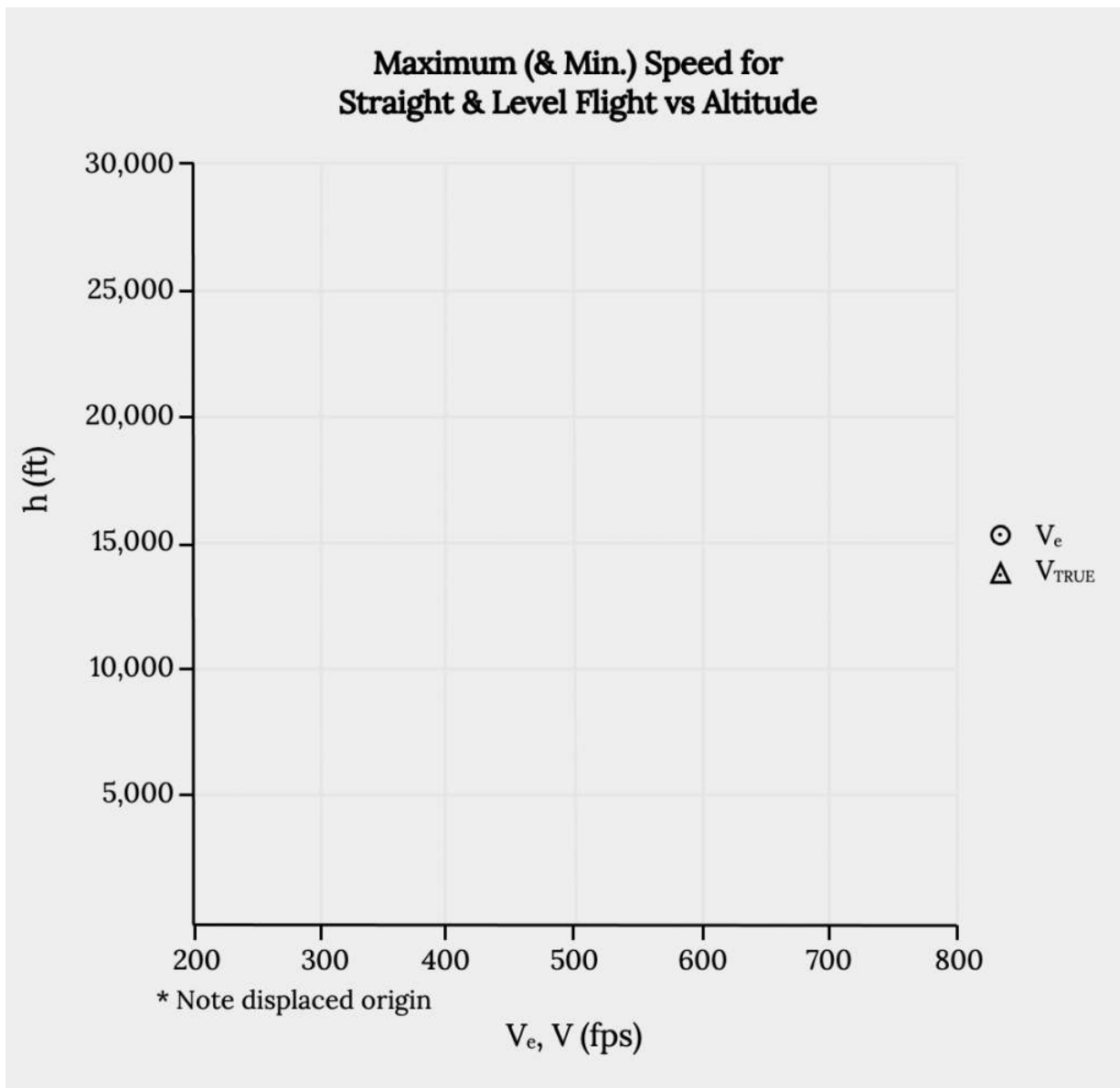

Figure 6.6: Maximum (& Min) Speed for Straight and Level Flight Versus Altitude

- c. find the altitude for maximum true airspeed.
- d. find the maximum obtainable altitude.
- e. compare V at minimum drag from the plot and the calculation.
- f. calculate $(L/D)_{max}$.

References

Figure 6.1: Kindred Grey (2021). "Finding Velocity for Maximum Range ." [CC BY 4.0](#). Adapted from James F. Marchman (2004). [CC BY 4.0](#). Available from <https://archive.org/details/6.1-updated>

Figure 6.2: Kindred Grey (2021). "Velocities for Minimum Power and Drag." [CC BY 4.0](#). Adapted from James F. Marchman (2004). [CC BY 4.0](#). Available from <https://archive.org/details/6.2-updated>

Figure 6.3: Kindred Grey (2021). "Speed for Best Range with Wind (Jet)." [CC BY 4.0](#). Adapted from James F. Marchman (2004). [CC BY 4.0](#). Available from <https://archive.org/details/6.3-updated>

Figure 6.4: Kindred Grey (2021). “Speed for Best Range with Wind (Prop).” [CC BY 4.0](#). Adapted from James F. Marchman (2004). [CC BY 4.0](#). Available from <https://archive.org/details/6.4-updated>

Figure 6.5: Kindred Grey (2021). “Thrust and Drag Versus V_e For Straight and Level Flight.” [CC BY 4.0](#). Adapted from James F. Marchman (2004). [CC BY 4.0](#). Available from <https://archive.org/details/hw-6-part-1>

Figure 6.6: Kindred Grey (2021). “Maximum (& Min) Speed for Straight and Level Flight Versus Altitude.” [CC BY 4.0](#). Adapted from James F. Marchman (2004). [CC BY 4.0](#). Available from <https://archive.org/details/hw-6-part-2>

-
1. The term “aero-plane” originally referred to a wing, a geometrically planar surface meant to support a vehicle in flight through the air. By 1903 the term had become associated with the entire flying vehicle. By the 1920s the American press and magazines had changed the word to “airplanes”; however, it is still common in Britain to see “aeroplane” used in books and papers. ↵

<!-- pb_fixme --><!-- pb_fixme -->

This page titled [6: Range and Endurance](#) is shared under a [CC BY 4.0](#) license and was authored, remixed, and/or curated by [James F. Marchman](#) ([Virginia Tech Libraries' Open Education Initiative](#)) via [source content](#) that was edited to the style and standards of the LibreTexts platform.

7: Accelerated Performance - Takeoff and Landing

Chapter 7. Accelerated Performance: Takeoff and Landing

Introduction

To this point, all of our discussion has related to static or unaccelerated flight where $F = ma = 0$. Even in climb and descent we assumed “quasi-level” conditions where the forces on the aircraft summed to zero. If we are to look at the performance of an airplane during take-off and landing we must, for the first time, consider acceleration (during takeoff) and deceleration (during landing). We will also have a couple of new forces to consider in the ground reaction force and ground friction.

In take-off, the airplane accelerates from zero groundspeed (but not necessarily zero airspeed!) to a speed at which it can lift itself from the ground. The thrust must exceed drag for acceleration to take place and the lift won't equal weight until the moment of lift-off. The plane may accelerate along the ground at a given angle of attack (or lift coefficient) until the speed reaches the point where the dynamic pressure combines with the lift coefficient to give lift equal to the weight or it may accelerate at some angle of attack determined by its landing gear height until it reaches a speed which will give lift equals to weight when the aircraft is then rotated (tail down, nose up) to a higher angle of attack and lift coefficient.

Any pilot will tell you that take-off and landing are what flight is all about. The thrill of full throttle and maximum acceleration as the plane roars down the runway, followed by the freeing of the soul which comes from cheating gravity and breaking the bond with the earth is incomparable. Of course the pilot hopes this occurs before the end of the runway is reached and in such a way as to allow clearance of the water tower at the end of the strip!

In landing, deceleration must be provided through braking, aerodynamic drag, ground friction and possibly reverse thrust to slow the plane to zero speed; hopefully before it reaches the end of the runway!

Landing is the ultimate challenge of person against nature as the pilot once again attempts to remain in control of a planned encounter with the ground in a vehicle moving at speeds which can result in instant mutilation and death if there is the slightest miscalculation of crosswind or downdraft. Of course, all of this must be done in such a manner as to assure the passenger that every move is as safe and natural and controlled as a Sunday afternoon drive to the golf course.

Wind will be a factor in take-off and landing and one would think it would be obvious that the pilot should position the aircraft at the end of the runway which will result in operation into the wind. This will result in a reduction in the length of the ground roll in either take-off or landing. To some, however this may not be obvious.

The author once sat on a graduate committee of a student in Transportation Engineering who had taken several courses in airport design. When asked what role the prevailing winds played in the design of airports the student appeared puzzled. Given a hint that it had something to do with the way the runways were aligned, he still drew a blank. Finally, when asked to draw a runway and show an airplane getting ready to take-off at one end and to explain which way the wind would be blowing, the student's eyes lit up in an apparent revelation of truth. He drew the runway horizontal across the center of the blackboard with the airplane at the right end, ready to begin a take-off roll toward the left. Then he triumphantly drew an arrow to indicate a wind moving from right-to-left, the same direction as the motion of the aircraft!

As despair and gloom settled over the faculty in the room I, rather reluctantly, asked him why the airplane would take-off in the same direction as the wind blew. He replied that the answer was obvious, **“So the wind will carry the pollution away with the airplane!”** Watch out for environmentalists who design airports!

To study aircraft performance in take-off and landing we must make sure we have proper definitions of what these phases of flight entail. Then we must consider the forces acting on the airplane. We will begin this study by looking at take-off.

7.1 Takeoff Performance

The definition used by the Federal Aviation Administration for take-off includes the ground run from zero ground speed to the point where the wheels leave the ground, plus the distance required to clear a 50 foot obstacle. The distance over the ground for all of the above is computed at maximum gross weight at sea level standard conditions. The “worst case” condition is often also calculated for a hot day at high altitude (100°F in Denver).

We will concern ourselves only with the ground run portion of the take-off run, knowing that we can find the distance to clear a 50 foot obstacle from our climb equations. That climb would be calculated for maximum angle of climb conditions.

The first step in the calculation of the ground run needed for take-off is an examination of the forces on the aircraft. In addition to the lift, drag, thrust and weight, we must now consider the ground friction and the “Resultant” force of the ground in supporting all or part of the weight of the aircraft. These are shown in the figure below. The coefficient of friction will depend on the ground surface and braking friction.

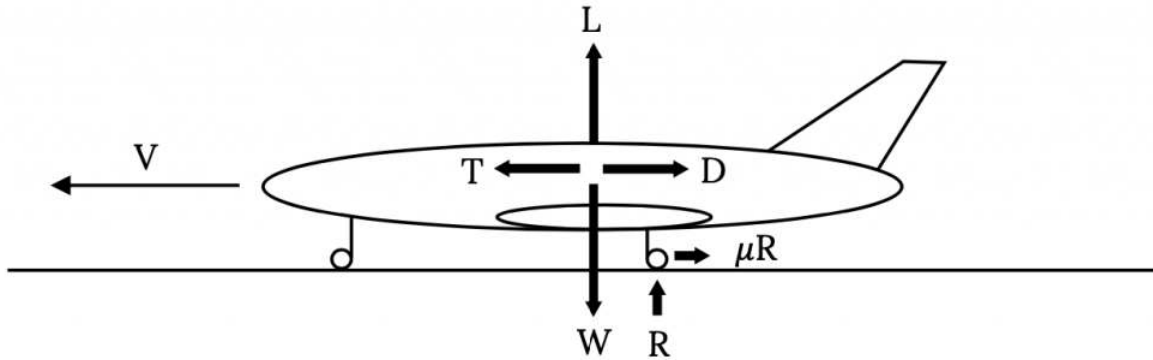

Figure 7.1: Forces on an Aircraft in Take-off or Landing

A summation of the vertical forces in Figure 7.1 gives

$$\mathbf{L} + \mathbf{R} - \mathbf{W} = \mathbf{0}$$

or

$$\mathbf{R} = \mathbf{W} - \mathbf{L}$$

Summing the horizontal forces gives

$$\mathbf{T} - \mathbf{D} - \mu\mathbf{R} = m\mathbf{dV}/\mathbf{dt}$$

Note that in the above relation we have, for the first time, an acceleration. These forces change as the aircraft accelerates from rest to take-off speed.

Combining the two equations above we have a single relation

$$\mathbf{T} - \mathbf{D} - \mu(\mathbf{W} - \mathbf{L}) = [\mathbf{W}/\mathbf{g}][\mathbf{dV}/\mathbf{dt}]$$

which can be rearranged to give

$$\mathbf{g}[(\mathbf{T}/\mathbf{W}) - \mu] - (\mathbf{g}/\mathbf{W})[\mathbf{D} - \mu\mathbf{L}] = \mathbf{dV}/\mathbf{dt}$$

Our desire is to integrate this or a related equation to get the time and distance needed for the take-off ground run. To do this we must first account for the dependence of both lift and drag on velocity. This gives

$$\mathbf{dV}/\mathbf{dt} = \mathbf{g}[(\mathbf{T}/\mathbf{W}) - \mu] - (\mathbf{g}/\mathbf{W})(1/2)\rho\mathbf{V}^2\mathbf{S}[\mathbf{C}_D - \mu\mathbf{C}_{Lg}],$$

where \mathbf{C}_{Lg} denotes the lift coefficient during the takeoff or landing ground run and not that in flight or at the point of takeoff or touchdown itself.

The above equation still contains thrust and weight, both of which may well change during the take-off ground run. Thrust is known to be a function of velocity, however, weight will be a function of the rate of fuel use (specific fuel consumption) and will be a function of time rather than speed. In order to keep our analysis relatively simple we will consider the weight change during the take-off roll to be negligible and treat weight as a constant in the equation. We will use the thrust model which we derived from the Momentum Equation in Chapter 2,

$$\mathbf{T} = \mathbf{T}_0 - \mathbf{aV}^2$$

In this equation T_0 is the thrust at zero velocity or the “static thrust”, a is a constant (which could be zero) and T is the thrust at any speed. Substituting this model for thrust into our acceleration equation gives:

$$dV/dt = g \{ (T_0/W) - \mu \} - (g/W) \{ (1/2)\rho S [C_D - \mu C_{Lg}] + a \} V^2$$

It should be noted that the velocity in this equation is the airspeed and not the speed relative to the ground. When we look at the take-off distance we will have to be concerned with both the ground speed and the airspeed. The simplest case will be when there is no ground wind; ie, when the airspeed and ground speed are equal.

In the above relation all of the terms in brackets and parentheses are essentially constant for a given aircraft at a given runway altitude and for a given runway surface. The lift coefficient is given the special designation of C_{Lg} to denote that it is the value for the ground run only. In a normal take-off roll the airplane accelerates to a pre-determined speed and then “rotates” to a higher angle of attack which will produce enough lift to result in lift-off at that speed. Hence, the ground run lift coefficient will probably not be the same as the take-off lift coefficient. The drag coefficient could be similarly subscripted; however, since C_D is a function of C_L and will subsequently be written in that manner, this will not be done at this point.

Since most of the terms in the equation can be treated as constants the equation can be simplified as follows:

$$dV/dt = A - BV^2,$$

where

$$A = g \{ (T_0/W) - \mu \}$$

and

$$B = (g/W) \{ (1/2)\rho S [C_D - \mu C_{Lg}] + a \}$$

This acceleration relationship can be integrated to obtain the time for the ground run of take-off.

$$\int_{t_1}^{t_2} dt = \int_1^{v_2} \frac{dV}{A - BV^2}$$

Assuming that the airplane starts the take-off run from rest and that there is no ground wind and that the upper limit is the take-off velocity V_{TO} , we have

$$t = \frac{1}{\sqrt{AB}} \tan^{-1} \left(V_{TO} \sqrt{\frac{B}{A}} \right) = \text{time for take-off.}$$

NOTE: This may be the first time that the reader has ever seen an **inverse hyperbolic tangent**. What should follow is a frantic search of your calculator to see if there is any such key or combination of keys along with an equally harried check of the indices of high school and college trig and calculus texts to see just what the heck this thing is. Waiting to figure this out during a test could result in considerable embarrassment.

A question which should be considered here is “What is a good value for the take-off speed?”

The very lowest speed at which the airplane can possibly lift off of the ground is the stall speed for straight and level flight at the runway altitude. It is, however, not safe to attempt takeoff at this minimum speed with the airplane right on the verge of stall. A somewhat higher than stall speed will give a margin of safety which will allow take-off at a fairly low speed without risk of stall due to unexpected gusts or similar problems. Commonly used values for take-off speed range from 10 to 20 percent higher than straight and level stall speed.

$$1.1 V_{\text{stall}} < V_{TO} < 1.2 V_{\text{stall}}$$

We will assume the higher value,

$$V_{TO} = 1.2 V_{\text{stall}},$$

unless told otherwise.

Far more important than the time required for the take-off ground run is the distance required. It is always nice to know that the pilot can get the airplane into the air before it reaches the end of the runway! To find the take-off distance we must integrate over distance instead of time.

$$dV/dS = (dV/dt)/dS/dt = (A - BV^2) / V$$

Rearranging this gives

$$V_{\text{stall}} = \sqrt{\frac{2W}{\rho S C_{L\text{MAX}}}} = 123.6 \text{ fps}$$

which is integrated to get

$$\frac{dV_G}{dt} = \frac{dV_A}{dt} = A - BV_A^2$$

Finally

$$S_2 - S_1 = \frac{1}{2B} \ln \left(\frac{A - BV_1^2}{A - BV_2^2} \right)$$

Now, assuming that the airplane starts from rest, no wind and lift off at V_{TO} we have

$$S_{TO} = \frac{1}{2B} \ln \left(\frac{A}{A - BV_{TO}^2} \right)$$

We will later investigate the case of take-off in a wind.

Before going further with an analytical analysis of the takeoff ground run it is worthwhile to pause and examine the physical aspects of the problem. These are too often lost in the equations, especially when we have hidden a lot of terms behind convenient terms like A and B. Let's first write the last equation for take-off distance in its full glory.

$$S_{TO} = \left(\frac{W}{g[\rho S (C_D - \mu C_{Lg}) + a]} \right) \ln \left(\frac{[(T_0/W) - \mu]}{[(T_0/W) - \mu] - (1/W)[(1/2)\rho S (C_D - \mu C_{Lg}) + a] V^2} \right)$$

It is obvious from the above equation that many factors influence the take-off distance.

It is, for example, intuitive that the ground friction will retard take-off. The retarding force due to friction will decrease as the lift increases during the take-off run. So, it appears that it might be to our advantage to move down the runway at a high angle of attack such that high lift is generated which will result in a reduction in the friction force and enhance the airplane's acceleration to take-off speed. On the other hand, a high angle of attack will also give a high drag coefficient, retarding acceleration. At some point in the take-off run the drag force will exceed the friction force. Does this mean the pilot should begin the take-off run at a high angle of attack and then lower it to reduce drag so as to hold some friction/drag ratio at an optimal value?

What about the value of the friction coefficient? Do we use one type of ground run on a concrete runway and another on a grass strip? What about soft dirt? Typical values of friction coefficient are:

Table 7.1: Typical Values of Friction Coefficients

Concrete, asphalt	0.02 - 0.05
Hard Turf	0.04 - 0.05
Normal turf, short grass	0.05
Normal turf, long grass	0.07 - 0.10
Soft ground	0.10 - 0.30

One should probably use the lower of the above values for a particular surface unless instructed to do otherwise.

For a "soft field" take-off such as on long grass or soft ground, pilots are taught to do several things to reduce the role of ground friction on the take-off roll. Usually, the use of flaps is recommended to increase the lift coefficient and, if the airplane has a tricycle type of landing gear (nose wheel and two main wheels), the pilot is taught to keep the nose up, which will both reduce the friction on that wheel and give a higher angle of attack and lift coefficient. One reason for the popularity of the "tail dragger" style of aircraft in the early days of aviation was its natural superiority in soft field takeoffs, which were common at the airfields of the day.

7.2 Minimum take-off ground run:

In a normal take-off, as mentioned earlier, the aircraft accelerates along the runway at a fairly constant angle of attack until the desired take-off speed is reached. The plane is then rotated to give an increased angle of attack and lift coefficient such that lift equals or exceeds the weight, allowing lift-off. The angle of attack during that ground roll and, hence the lift and drag coefficients, is largely determined by the relative lengths of the landing gear and the angle at which the wing is attached to the fuselage.

Many factors influence the size and placement of the landing gear. It is nice if the gear struts are long enough to keep the propeller from hitting the runway (this can be a real problem with a tail mounted prop) and it is also good if the center of gravity of the aircraft is between the main and auxiliary gear. The main gear should be close to the CG to allow ease of rotation but far enough away to prevent inadvertent rotation. There is also the question of where the gear are stored in a retractable system

The wing angle of placement on the fuselage will primarily be a function of optimal cruise considerations such that things like the fuselage drag is minimized and pilot visibility is satisfactory when the wing is at the best combination of lift and drag coefficient for cruise as determined by using relations of previous chapters. It is also nice if, in cruise conditions, the aisle in a commercial aircraft is relatively level.

An important task for the designer is to find the wing angle of attack which will minimize the take-off ground run and then to design the landing gear such that under normal conditions the plane sits on its gear with the wing at that angle. Let's try to find that angle or, more precisely, the lift and drag coefficients at that angle of attack.

We first return to the equation for acceleration in the ground run.

$$\frac{dV}{dt} = g \left(\frac{T_0}{W} - \mu \right) - \frac{g}{W} \left[\frac{1}{2} \rho S (C_D - \mu C_{Lg}) + a \right] V^2$$

Our desire is to maximize this acceleration at all times during the run. Assuming that the only variable we have is angle of attack, i.e., C_L and C_D , assuming that we have a parabolic drag polar, and further assuming that the take-off speed V_{TO} is independent of C_{Lg} , we can find the maximum acceleration by taking the derivative with respect to C_{Lg} and equating the result to zero. The assumption that V_{TO} is independent of C_{Lg} means that the plane will be rotated at V_{TO} to achieve lift off rather than allowed to continue to accelerate until lift off occurs at C_{Lg} .

$$\frac{d}{dC_L} \left(\frac{dV}{dt} \right) = \frac{d}{dC_L} (C_D - \mu C_{Lg}) = \frac{d}{dC_L} (C_{D0} + K C_{Lg}^2 - \mu C_{Lg}) = 0$$

or

$$2K C_{Lg} - \mu = 0$$

This gives the best value of the ground run lift coefficient for minimum ground run length.

$$C_{Lg} = \mu / 2K$$

7.2.1 Airplane design note

This tells us that if we want to take-off in the shortest possible ground run distance we will design the airplane so that with a normal load distribution on the runway its wing will be at the angle of attack which will give the above value of lift coefficient. We may be able to do this by making the wheel struts or supports the right length. In other words, a well designed airplane will have its wing attached to the fuselage at an angle so the fuselage is level at cruise conditions and will have its landing gear height set to put the wing at the optimum take-off angle of attack at maximum gross weight conditions when sitting on the ground.

It might be interesting to see just how much difference having the optimum ground run lift coefficient makes by finding the best C_{Lg} for takeoff and then calculating the resulting takeoff distance as well as the distance at somewhat higher and lower values of C_L .

7.2.2 Power based engine performance

A factor not previously noted in this discussion is that we have accounted for the output of the aircraft's propulsion system in terms of thrust and not power. This was natural because we were dealing with force equations. What do we do when we have an aircraft which has a power based propulsion system (propeller)? We know that thrust is equal to power divided by velocity but how do we use that in the equations? Perhaps an example will provide an answer:

EXAMPLE 7.1

For an aircraft with the following properties find the minimum ground run distance at sea level standard conditions.

$$W = 56,000 \text{ lb}$$

$$V_{TO} = 1.15 V_{stall}$$

$$\eta_p = 0.75$$

$$S = 1000 \text{ sq. ft.}$$

$$C_D = 0.024 + 0.04C_L^2$$

$$T_0 = 13000 \text{ lb}$$

$$C_{Lmax} = 2.2$$

$$\mu = 0.025$$

$$P_s = 4800 \text{ hp}$$

Let's first find the stall speed and then the take-off speed.

$$V_{stall} = [(2W)/(\rho S C_{Lmax})]^{1/2} = 146 \text{ fps}$$

$$V_{TO} = 1.15 V_{stall} = 168 \text{ fps.}$$

Now we must face the problem of having **power** information and equations that demand **thrust** data. We have been given the **static thrust** and we can assume that the power available which was given will be the **power in use at the moment of take-off**. We then have to determine how thrust varies and how to fit it to our assumed thrust versus velocity relation used in the take-off acceleration equation.

At take-off speed

$$P_{avail} = \eta_p P_s = 0.75(4800\text{hp}) = 3600\text{hp}$$

so, the thrust at take off is

$$T_{TO} = P_{av}/V_{TO} = 3600 \text{ hp} / 168 \text{ fps} = (1980000 \text{ ft-lb/sec}) / 168 \text{ fps} = 11786 \text{ lb}$$

Our thrust versus velocity relationship is

$$T = T_0 - aV^2.$$

Substituting the takeoff speed and thrust and the static thrust we can find the value for a.

$$\begin{aligned} 11786 \text{ lb} &= 13000 \text{ lb} - a (168 \text{ fps})^2 \\ a &= 0.0430 \text{ lb-sec}^2/\text{ft}^2 \end{aligned}$$

Our thrust relationship to be used in the take-off equations is then

$$T = 1300 - 0.0430 V^2.$$

Now we need to determine the lift coefficient for minimum ground run.

$$C_{Lg} = \mu/2K = 0.025/0.080 = 0.3125$$

The drag coefficient at the minimum ground run lift coefficient is:

$$C_D = C_{D0} + K C_L^2 = 0.024 + 0.04(0.3125)^2 = 0.0279$$

Finally we can use all of the above to determine the take-off ground run.

$$S = \frac{1}{2B} \ln \left(\frac{A}{A - B V_{TO}^2} \right) \quad A = g \left(\frac{T_0}{W} - \mu \right) = 32.2 \text{ ft/sec}^2 \left(\frac{13000}{56000} - 0.025 \right) = 6.65 \text{ ft/sec}^2 \quad B = \frac{g}{W} \left[\frac{1}{2} \rho S (C_D - \mu C_{Lg}) + a \right] = 3.80 \times 10^{-5} \text{ ft}^{-1}$$

$$S = \frac{1}{2(3.8 \times 10^{-5})} \text{ ft} \times \ln \frac{6.65}{6.65 - (3.8 \times 10^{-5})(168)^2}$$

$$S = 2314 \text{ ft.}$$

7.3 Takeoff Without Rotation

As described previously, a conventional take-off run would be made at the angle of attack dictated by the airplane configuration and the landing gear geometry, all of which has probably been designed to give near optimal ground run acceleration. When a predetermined take-off speed is reached the pilot raises the nose of the aircraft to increase the angle of attack and give the lift needed for lift-off. But, what would happen if, instead of rotating, the airplane was allowed to simply continue to accelerate until it gained enough speed to lift off without rotation?

Continued ground run acceleration to take-off without rotation is not an optimum way to achieve flight. It will always require more runway than a conventional take-off. There are, however, a limited number of aircraft which are designed for this type of lift-off. One well known example is the B-52 bomber. This aircraft has what might be described as “bicycle” type landing gear with the gear located entirely in the long fuselage and placed well fore and aft the center of gravity. This placement and the long, low fuselage make rotation virtually impossible. The result is the need for very long runways and very long, shallow approaches to landing.

Optimizing the takeoff run for an aircraft like the B-52 is different from the maximum acceleration optimum for a conventional take-off. Since the plane cannot rotate, the gear design and wing placement on the fuselage must be arranged such that the wing angle of attack is that desired for a safe and efficient lift-off. Too high an angle of attack might result in take-off at conditions too near stall and too low an angle might require too much runway. In the following example we look at such an aircraft where the design is such that the ground run angle of attack of the wing is set to give take-off at a speed 20% above stall speed.

EXAMPLE 7.2

The aircraft defined below is designed for take-off with no rotation, thus the ground run angle of attack (and, therefore, C_L and C_D) is the same as that at take-off. Find the take-off distance at sea level standard conditions.

$$\begin{aligned} W &= 75,000 \text{ lb} \\ C_D &= 0.02 + 0.05C_L^2 \\ \mu &= 0.02 \\ S &= 2500 \text{ sq. ft.} \\ C_{L_{\max}} &= 1.5 \\ T = T_0 &= 12,000 \text{ lb} \\ V_{TO} &= 1.2 V_{\text{STALL}} \end{aligned}$$

We must first find the stall speed, the take-off speed, and the related take-off (and, thus, ground run) lift coefficient.

$$V_{\text{stall}} = [(2W)/(\rho S C_{L_{\max}})]^{1/2} = 129.7 \text{ fps}$$

$$V_{TO} = 1.2 V_{\text{stall}} = 155.7 \text{ fps.}$$

We can then find the lift coefficient for this take-off speed.

$$C_{Lg} = C_{LTO} = W / (1/2 \rho V_{TO}^2 S) = 1.042$$

Actually we could have skipped some of the above as we realized the following.:

$$C_{Lg} = C_{LTO} = [V_{\text{stall}}/V_{TO}]^2 C_{L_{\max}} = [1/1.2]^2 (1.5) = 1.042$$

Using the above lift coefficient we find the drag coefficient.

$$C_D = C_{D0} + K C_L^2 = 0.02 + 0.05(1.042)^2 = 0.0742$$

We are now ready to find the takeoff distance.

$$S = \frac{1}{2B} \ln \left(\frac{A}{A - B V_{TO}^2} \right) \quad A = g \left(\frac{T_0}{W} - \mu \right) = 4.54 \text{ ft/sec}^2 \quad B = \frac{g}{W} \left[\frac{1}{2} \rho S (C_D - \mu C_{Lg}) + a \right] = 6.85 \times 10^{-5} \text{ ft}^{-1} \quad S = \frac{10}{2(6.85)} \ln \left(\frac{4.54}{4.54 - (6.85 \times 10^{-5}) (155.7)^2} \right)$$

$$S = 3324 \text{ ft.}$$

7.4 Thrust Augmented Take-off

Although not commonly seen today, a technique once regularly used by military cargo aircraft and bombers like the B-52 to reduce the take-off distance involved the augmentation of ground run thrust through the use of strap-on or built in solid rockets. This system was often referred to as JATO for jet assisted take-off even though it used rockets and not jets. Calculation of ground runs for this type of take-off require breaking the ground run distance integral into two parts to account for the two different levels of thrust used in the run. The resulting equation is as follows:

$$S_{TO} = \frac{1}{2B} \ln \left[\frac{A}{A - B \left(\frac{V_{TO}}{2} \right)^2} \right] + \frac{1}{2B} \ln \left[\frac{A_1 - B \left(\frac{V_{TO}}{2} \right)^2}{A_1 - BV_{TO}^2} \right]$$

$$A_1 = g \left(\frac{T_0 + T_R}{W} - \mu \right).$$

Let us return to the last example and see what happens if we try to shorten the ground run of this airplane by the use of 15,000 pounds of extra thrust obtained from JATO units which are fired for the first ten seconds of the ground run to boost the plane's initial acceleration.

The total thrust during the first ten seconds of the ground run will be 27,000 pounds. Thus, for that portion of the run the A term in the ground run distance equation will be

$$A = g \left(\frac{T_0 + T_R}{W} - \mu \right) = 32.2 \left(\frac{27000}{7500} - 0.02 \right) = 11.0 \text{ft/sec}^2$$

The B term will not be changed.

Now we must determine the velocity of the aircraft at the end of this first ten seconds of acceleration since the limits on the distance equation are velocities. To find this we go to the relationship for take-off ground run time

$$t_1 - t_0 = \frac{1}{\sqrt{AB}} \left[\tan^{-1} \left(V_1 \sqrt{\frac{B}{A}} \right) - \tan^{-1} \left(V_0 \sqrt{\frac{B}{A}} \right) \right]$$

Since the initial velocity is zero and $t_1 - t_2 = 10$ sec we have

$$10 \cdot \sqrt{AB} \text{sec} = \tan^{-1} \left(V_1 \sqrt{\frac{B}{A}} \right)$$

Solving gives the speed at the end of the augmented thrust portion of the take-off run.

$$V_1 = 107 \text{ fps.}$$

At this point it wouldn't hurt to check the units in the equations above and make sure that we really did end up with units of feet per second.

The entire distance for take-off can now be found as follows:

$$S_1 - S_0 = \frac{1}{2B} \ln \left(\frac{A}{A - BV_1^2} \right) = 540 \text{ft} \quad S_2 - S_1 = \frac{1}{2B} \ln \left(\frac{A - BV_1^2}{A - BV_2^2} \right) = 1939 \text{ft}$$

$$S_{\text{TOTAL}} = 2480 \text{ ft.}$$

The JATO boost in this example gave a 25% reduction in the ground run needed for takeoff. This could be important for such an aircraft if it is operating out of short, remote airfields often found in "third world" countries or in military operations.

7.5 Ground Wind Effects

Earlier we mentioned the importance of ground wind in the take-off of aircraft. It is rare that a ground wind does not exist, thus, our "no-wind" equations are, hopefully, worst case predictions since taking off into the wind will reduce the distance for the ground run. Finding the distance required for take-off into a ground wind (assuming the pilot has the good sense to fly into the wind and not attempt a "downwind" take-off) requires another look at the equations. *Note: There are sometimes conditions such as "downhill" runways or end-of-runway obstacles which may at times necessitate a downwind takeoff.*

In the take-off equations it is important to realize that, as noted when first presented, the distance and acceleration are measured relative to the ground; however, the aerodynamic forces in the equations are obviously dependent on airspeed and not ground

speed. We must consider this in our equations. In doing so we will use the following designations for different speeds:

$V_G = \text{GROUND SPEED}$

$V_A = \text{AIRSPEED}$

$V_W = \text{WIND SPEED (PARALLEL TO RUNWAY)}$

This gives

$$V_A = V_G \pm V_W \text{ (+ if a head wind, - if a tail wind).}$$

Returning to the basic equation of motion we have

$$dV_G/dt = A - BV_A^2$$

However,

$$V_G = V_A \pm V_W$$

Thus

$$dV_G/dt = dV_A/dt = A - BV_A^2.$$

So, to determine the time for take-off we use

$$dt = dV_A / (A - BV_A^2).$$

To find take-off distance we use

$$\frac{dV_G}{dS} = \frac{dV_G/dt}{dS/dt} = \frac{dV_A/dt}{dS/dt} = \frac{1}{V_G} \frac{dV_A}{dt}$$

or

$$V_G \frac{dV_G}{dS} = \frac{dV_A}{dt} = V_G \frac{dV_A}{dS}$$

This becomes

$$(V_A \pm V_W) \frac{dV_A}{dS} = \frac{dV_A}{dt} = A - BV_A^2$$

Finally we have a differential which includes wind effects. We will write it only for the case of the headwind since this would be the normal situation.

$$dS = \frac{V_A dV_A}{A - BV_A^2} - V_W \frac{dV_A}{A - BV_A^2}$$

Now, we must also note that the take-off speed of the aircraft is **airspeed** and not ground speed. The time and distance equations above may be integrated above to give

$$t_2 - t_1 = \frac{1}{\sqrt{AB}} \left[\tan^{-1} \left(V_{A_2} \sqrt{\frac{B}{A}} \right) - \tan^{-1} \left(V_{A_1} \sqrt{\frac{B}{A}} \right) \right]$$

$$S_2 - S_1 = \frac{1}{2B} \ln \left(\frac{A - BV_{A_1}^2}{A - BV_{A_2}^2} \right) - V_W (t_2 - t_1)$$

Finally, realizing that take-off usually starts from rest at zero ground speed (at $t = 0$), we obtain

$$t = \frac{1}{\sqrt{AB}} \left[\tan^{-1} \left(V_{A_{TO}} \sqrt{\frac{B}{A}} \right) - \tan^{-1} \left(V_W \sqrt{\frac{B}{A}} \right) \right]$$

$$S = \frac{1}{2B} \ln \left(\frac{A - BV_W^2}{A - BV_{A_{TO}}^2} \right) - V_W t$$

Note that the take-off speed in these equations is the **airspeed** for takeoff and not the ground speed.

7.6 Landing

Landing, like take-off, is properly defined as having at least two parts; an “approach” over a 50 foot obstacle to touchdown and the landing ground run. These, in turn, might be divided into several other segments. The approach will usually not be a non-powered glide as studied earlier. The normal approach to landing for most aircraft is a powered descent. The FAA definition of the landing terminal glide over an obstacle is, however based on an unpowered glide as the limiting case. We have already considered gliding

flight and should be able to deal with this portion of flight. A real descent can be the most interesting portion of the flight for a pilot as he or she corrects for side-winds, updrafts, and downdrafts while aiming for a hoped-for touchdown point on the runway. All of this is done at a descent rate of about 500 feet per minute (about 8 mph).

Here we will concern ourselves with only the touchdown through full stop portion of the landing. Again our primary concern will be ground run distance with the hope that full stop occurs before the end of the runway.

The equations of motion for the landing ground run are identical to those for takeoff, however, the terms in the equations can assume very different magnitudes from those in take-off. To slow the aircraft in its landing ground run high drag is desirable, negative or “reverse” thrust may be used, and brakes will be used during much of the run to greatly increase the friction term. The boundary conditions on the integrals are essentially reversed with the initial speed being the touchdown or “contact” speed and the final ground speed being zero; however the solution may need to be broken into several segments to account for a sequence of events as part of the landing ground roll.

Before we look at the equations let’s look at a typical landing as seen by a small plane, general aviation pilot. The approach-to-landing descent will probably be made using full flaps, at least in its final “glide” (this will be true for almost any aircraft). This will lower the stall speed and allow approach and touchdown at a lower flight speed. It will also steepen the approach glide and, on the ground, add to the drag to help slow the aircraft.

As soon as the pilot feels that the aircraft is under full control after touchdown he or she may raise the flaps. While this reduces the drag and contributes to a longer ground roll, it also reduces the lift, increasing ground friction forces and allowing better directional control of the aircraft in a crosswind. After this is done the brakes will be applied to further slow the aircraft to a stop. Larger, jet aircraft may apply reverse thrust very soon after touchdown and before use of brakes to improve deceleration.

Now, let’s look again at the equations of motion for an aircraft on the ground. We can still use

$$dS = VdV / (A - BV^2) .$$

We define V_C as the speed of initial ground contact on landing at some point defined as S_1 and conditions at the next point in the ground roll sequence as S_2 and V_2 , giving the following integrated equation:

$$\Delta S = S_2 - S_1 = [1/(2B)] [\ln(A - BV_2^2) - \ln(A - BV_C^2)]$$

or

$$\Delta S = S_2 - S_1 = [1/(2B)] \ln[(A - BV_C^2) / (A - BV_2^2)]$$

In the rare case where none of the parameters in the equation (T , μ , C_{Lg} , etc.) change during the ground run; i.e., where the airplane simply touches down and coasts to a stop, our final speed $V_2 = 0$, giving

$$S = \frac{1}{2B} \ln\left(1 - \frac{B}{A} V_C^2\right)$$

For a first estimate of a minimum landing ground run one could assume that the pilot is able to apply the brakes almost instantly after touchdown and that thrust is simply zero during the entire roll and, thus, use the above equation to calculate a landing ground roll distance. In reality, as mentioned previously, the ground roll would have to be determined by adding a series of the previous ΔS equations, each with its appropriate starting and ending speeds and values for thrust and friction and the like.

$$S_{ldg} = \Delta S_1 + \Delta S_2 + \Delta S_3, \text{ etc.}$$

The time for the landing ground roll is found from

$$dV/dt = A - BV^2$$

or

$$t_2 - t_1 = \int dt = \int_{V_1}^{V_2} \frac{dV}{A - BV^2}$$

Integration of this equation can take several different forms depending on the relative magnitudes and signs of A and B. Looking again at these terms

$$A = g \left(\frac{T_0}{W} - \mu \right) \quad B = \frac{g}{W} \left[\frac{1}{2} \rho S (C_D - \mu C_{Lg}) + a \right]$$

note that A will almost always be negative since thrust will always be zero or negative, if not at touchdown, then very quickly thereafter. Braking forces could also be large enough to make B negative, depending on the relative magnitudes of the lift and drag coefficients. In various landing situations it may be possible to have any combination of negative or positive terms and this affects the form of the integral. The difficulty arises in the fact that integration gives a square root of the product of A and B as well as other terms with square roots of A and B individually or ratios of A and B. **The result can be an imaginary answer if the correct solution is not chosen.**

The time of landing ground roll solution is given for the four possible combinations of A and B below.

$$1. A > 0, B > 0 : t_2 - t_1 = \frac{1}{2 \cdot \sqrt{AB}} \ln \left[\frac{\sqrt{A} + V \cdot \sqrt{B}}{\sqrt{A} - V \cdot \sqrt{B}} \right] \quad 0, B > 0 : t_2 - t_1 = 12 \cdot AB \ln A + V \cdot BA - VB$$

$$2. A > 0, B < 0 : t_2 - t_1 = \frac{1}{\sqrt{-AB}} \tan^{-1} \left(V \sqrt{\frac{-B}{A}} \right) \quad 0, B < 0 : t_2 - t_1 = 1 - AB \tan^{-1}(V - BA)$$

$$3. A < 0, B > 0 : t_2 - t_1 = \frac{1}{\sqrt{-AB}} \tan^{-1} \left(V \sqrt{\frac{B}{-A}} \right) \quad 0 : t_2 - t_1 = 1 - AB \tan^{-1}(VB - A)$$

$$4. A < 0, B < 0 : t_2 - t_1 = 12AB \ln[V - B - AV - B + A]$$

7.7 Effect of Wind on Landing Ground Roll

As in the case of taking off, all landings should be made into the wind (with the same exceptions noted for take-off). The equations must then be written to account for the different velocity terms. This is done exactly as it was for the take-off case.

$$dV_g/dS = (dV_g/dt)/(dS/dt) = [A - BV_A^2] / V_g$$

or

$$V_g(dV_g/dS) = A - BV_A^2 = V_g(dV_g/dS)$$

For the headwind case this gives:

$$(V_A - V_w)(dV_A/dS) = A - BV_A^2$$

and

$$dS = \frac{V_A dV_A}{A - BV_A^2} - V_w \frac{dV_A}{A - BV_A^2}$$

Integrating and noting that when the aircraft has come to rest on the ground the velocity will equal that of the wind component along the runway V_w ,

$$S = \frac{1}{2B} \ln \left(\frac{A - BV_C^2}{A - BV_w^2} \right) - V_w (t_2 - t_1)$$

The last term is evaluated using the time equation already discussed.

EXAMPLE 7.3

The following aircraft touches down in landing at a speed 30% above its stall speed. The pilot applies the brakes when the plane has slowed to 80% of its touchdown speed. If there is no wind, find the distance required for the aircraft to come to a complete stop on the runway.

$$\begin{aligned} W &= 30,000 \text{ lb} \\ \mu_B &= 0.5 \\ \mu &= 0.02 \\ S &= 750 \text{ sq.ft} \\ C_{L_{\max}} &= 2.2 \text{ (with flaps)} \end{aligned}$$

Assume that the **lift-to drag ratio at 1.3 times the stall speed has a value of eight** and is constant throughout the ground roll and that thrust is zero at touchdown and throughout the ground roll.

Since everything is related to the stall speed we will first find its value.

$$V_{\text{stall}} = [2W / (\rho S C_{L_i})]^{1/2} = 123.6 \text{ fps}$$

giving a touchdown speed of

$$V_c = 1.3V_{\text{stall}} = 160.7 \text{ fps}$$

This speed gives a lift coefficient of

$$C_{L_g} = C_{L_{vc}} = 2W / (\rho S C_L^2) = 1.30$$

We will assume this lift coefficient is constant through the ground run.

We were not given a drag polar equation or its constants but we do know the lift-to-drag ratio and can find the drag and drag coefficient as follows:

$$D_{VC} = W/(L/D) = 3750 \text{ lb}, C_{Dg} = D/[1/2\rho V_C^2 S] = 0.1627 .$$

Now we can find the A and B terms for the distance solution. We must solve for the distance in two parts, the distance between touchdown and application of the brakes and the remaining distance to full stop.

Before braking

$$(\mu = 0.02) \quad A_1 = g \left(\frac{T}{W} - \mu \right) = -0.6434 \text{ ft/sec}^2 \quad B_1 = \frac{g}{W} \left[\frac{1}{2} \rho S (C_D - \mu C_{L_g}) + a \right] = 1.3085 \times 10^{-4} \text{ ft}^{-1}$$

giving a distance of

$$S_1 = \frac{1}{2B_1} \ln \left[\frac{A_1 - B_1 V_C^1}{A_1 - B_1 V_B^2} \right] = 1376 \text{ ft}$$

After braking

$$(\mu = 0.5)$$

$$A_2 = g \left(\frac{T}{W} - \mu_B \right) = -16.085 \text{ ft/sec}^2$$

$$B_2 = \frac{g}{W} \left[\frac{1}{2} \rho S (C_D - \mu_B C_{L_g}) \right] = 4.663 \times 10^{-4} \text{ ft}^{-1}$$

giving the rest of the ground roll distance as:

$$S_2 = \frac{1}{2B_2} \ln \left(\frac{A_2 - B_2 V_B^2}{A_2} \right) = 699.4 \text{ ft}$$

The total ground roll in landing is the sum of the two distances above:

$$S_{\text{TOT}} = S_1 + S_2 = 2075.4 \text{ ft.}$$

7.8 FAA AND OTHER DEFINITIONS OF TAKEOFF AND LANDING PARAMETERS

7.8.1 Takeoff

As discussed earlier, there are many components which may be included in the calculations of takeoff and landing distances. In the previous calculations only the actual ground run distances were considered and these, especially during landing, may be composed of multiple segments where different values of friction coefficient and thrust apply. A complete look at takeoff must also include the distance between the initiation of rotation and the establishment of a constant rate of climb and the distance needed to clear a defined obstacle height as shown in the figure below.

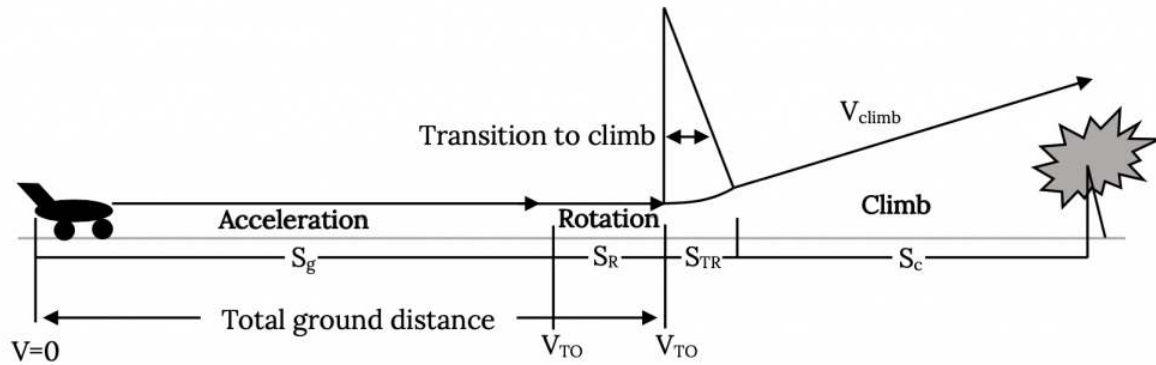

Figure 7.2: Takeoff Segments

Several different terms may be used in a complete discussion of takeoff. These include the following:

Ground Roll: The distance from the start of the ground run or release of brakes until the point where the wheels leave the ground. This includes the distance needed to achieve the needed lift to equal the weight during rotation. The takeoff velocity must be at least 1.1 times the stall speed and is normally specified as between 1.1 and 1.2 times that speed.

Obstacle Clearance Distance: The distance between the point of brake release and that where a specified altitude is reached. This altitude is usually defined as 50 feet for military or smaller civil aviation aircraft and 35 feet for commercial aircraft.

Balanced Field Length: The length of the field required for safe completion of takeoff should one engine on a multi-engine aircraft fail at the worst possible time during takeoff ground run. This distance includes the obstacle clearance distance. The balanced field length is sometimes also called the **FAR Takeoff Field Length** because it is a requirement for FAA certification in FAR 25 for commercial aircraft and includes the 35 foot obstacle clearance minimum. In the early part of the takeoff ground run the loss of one engine would usually lead to a decision to abort the takeoff, apply brakes and come to a stop. The “worst possible time” for engine failure would be when it is no longer possible to stop the aircraft before reaching the end of the runway and the decision must be made to continue the takeoff with one engine out.

Decision Speed (V_1): The speed at which the distance to stop after the failure of one engine exactly equals the distance to continue takeoff on the remaining engines and to clear the FAA defined obstacles. In calculating this speed one cannot assume the possibility of using reverse thrust as part of the braking process.

7.8.2 Landing

As in takeoff, landing includes several possible segments as shown in Figure 7.3. Our previous calculations included only the actual ground roll distance but a complete definition may also include the portion of the approach needed to clear a defined obstacle and that needed to transition from a steady approach glide to touchdown (the “flare distance”). Note that the landing ground run could also include portions with reversed thrust used alone or with the brakes.

The weight of the aircraft at landing is normally less than that at takeoff due to the use of fuel during the flight, however it is common to calculate the landing distance of trainer aircraft and of most propeller driven aircraft at takeoff weight. For non-trainer jets, landing weight is normally assumed to be 85% of the takeoff weight. Military requirements usually assume landing with a full payload and about half of the fuel.

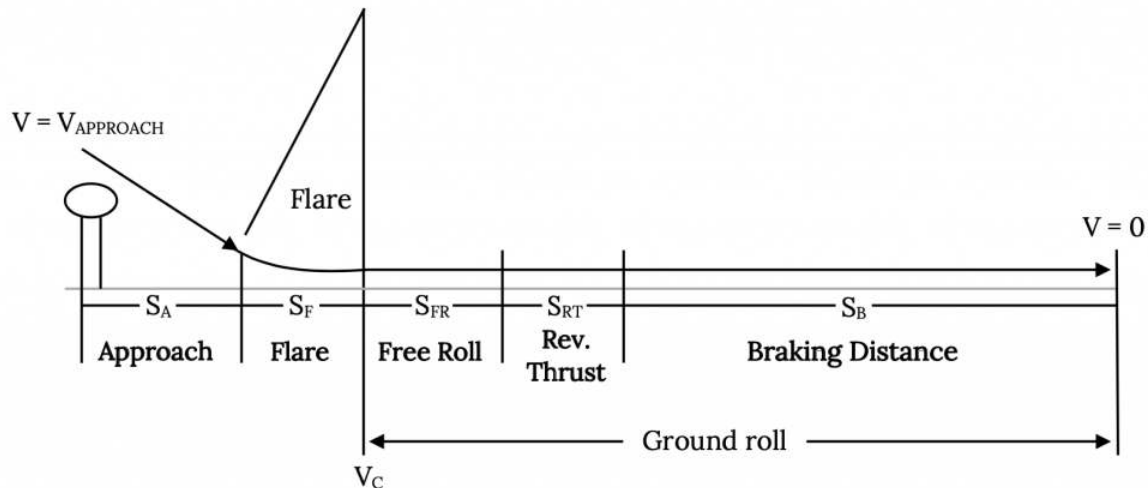

Figure 7.3: Landing Segments

As in takeoff, there are several definitions associated with landing which should be familiar to the performance engineer:

FAR 23 Landing Field Length: This distance includes that needed to clear a 50 foot obstacle at approach speed flying down a defined approach glidepath (normally about 3 degrees). Touchdown is usually at about 1.15 times the stall speed. This total distance is usually about twice that of the calculated ground roll distance. This distance is normally about the same as that specified in requests for proposals for military aircraft.

FAR25 Landing Field Length: This distance adds to that of FAR 23 above an arbitrary two-thirds as a safety margin.

Homework 7

1. An aircraft has the following specifications:

$$W = 24,000 \text{ lb}$$

$$S = 600 \text{ ft}^2$$

$$C_{D0} = 0.02$$

$$K = 0.056$$

This aircraft has run out of fuel at an altitude of 30,000 ft. Find the *initial* and *final* values of its airspeed for *best range*, the glide angle for best range, its rate of descent at this speed, and the time taken to descend to sea level at this speed.

2. For the aircraft above, assume a sea level thrust of 6,000 pounds and assume that thrust at altitude is equal to the sea level thrust times the density ratio (σ). Find the *true* airspeeds for best rate of climb at sea level, at 20,000 ft, 30,000 ft and 40,000 ft. Also find the ceiling altitude.

3. For an aircraft where:

$$W = 10,000 \text{ lb}$$

$$W/S = 50 \text{ psf}$$

$$C_{D0} = 0.015$$

$$K = 0.02$$

Find the best rate of climb and the velocity for best rate of climb at sea level where $T = \text{constant} = 4,000 \text{ lb}$ and at an altitude of 40,000 ft where $T = 2,000 \text{ lb}$.

References

Figure 7.1: Kindred Grey (2021). “Forces on an Aircraft in Take-off or Landing.” [CC BY 4.0](#). Adapted from James F. Marchman (2004). [CC BY 4.0](#). Available from <https://archive.org/details/7.1-updated>

Figure 7.2: Kindred Grey (2021). “Takeoff Segments.” [CC BY 4.0](#). Adapted from James F. Marchman (2004). [CC BY 4.0](#). Available from <https://archive.org/details/7.2-updated>

Figure 7.3: Kindred Grey (2021). “Landing Segments.” [CC BY 4.0](#). Adapted from James F. Marchman (2004). [CC BY 4.0](#). Available from <https://archive.org/details/7.3-updated>

<!-- pb_fixme --><!-- pb_fixme -->

This page titled [7: Accelerated Performance - Takeoff and Landing](#) is shared under a [CC BY 4.0](#) license and was authored, remixed, and/or curated by [James F. Marchman](#) (Virginia Tech Libraries' Open Education Initiative) via [source content](#) that was edited to the style and standards of the LibreTexts platform.

8: Accelerated Performance - Turns

Introduction

Historical Introduction

Thus far all of our performance study has involved straight line flight. Unfortunately, unless our airplane is flying from a runway that is exactly in line with our destination runway and there is no wind on the route, straight line flight isn't very practical! We need to be able to turn.

While the need to be able to turn is fairly obvious to us, a look at early aviation will show that it often was the last thing on the mind of many aviation pioneers. The uniqueness of the Wright Flyer was not its ability to fly a few feet in a straight line over the sand at Kitty Hawk. It was unique in its ability to turn and maneuver. There are claims that earlier experimenters in England, France, Russia, and the United States may indeed have made short, uncontrolled "hops" or even legitimate straight line "flights" in powered vehicles before December 17, 1903 but there are no claims for "controlled" flight of a powered, heavier than air, man (or woman) carrying vehicle prior to this date.

There are several ways to turn a vehicle in flight. Early experimenters such as Otto Lilienthal in Germany and Octave Chanute in this country knew that shifting the weight of the "pilot" suspended beneath their early "hang gliders" would tilt or "bank the wings to allow turns. Others such as Samuel P. Langley, the turn of the century director of the Smithsonian who had government funding to build and fly the first airplane, designed their craft to be steered with a rudder like a ship. Neither method of turning was very efficient. Langley's heavier than air powered models, for example, flew very well but couldn't adjust for winds and flew in long circles instead of a straight line as they had been designed to do.

Banking the wings (called the "aero-planes" in the 1890's) tilts the lift force to the side and the sideward component of the lift results in a turn, but since part of the lift is now being used to turn the vehicle the remaining lift may not be enough to oppose the weight unless additional power is added. Using a rudder alone results in a side force on the fuselage of the aircraft and, hence, a turning force. The resulting turn, by causing one wing to move forward faster than the other, usually leads to a bank. Neither method, employed alone, provides a very satisfactory means of turning and the result is usually a very large radius turn. Many early experimenters, in fact, appeared to want to turn without banking since they were "flying" very close to the ground and a banked wing might touch the ground and cause a crash.

The Wright brothers designed a complex mechanism involving coordinated rudders and twisting of wings to combine both roll and yaw in a "coordinated", efficient turn. Their original purpose may have actually been to try to bank the airplane opposite the turn to prevent ground contact by the wing but they found that a properly coordinated turn could make their vehicle quite maneuverable. When the Wrights took their aircraft to Europe in 1908 they amazed European aviators with their craft's ability to turn and maneuver. French airplanes, which were the most sophisticated in Europe, used only rudders to turn. The Wright Flyer, with its "wing warping" system and coordinated rudder, was literally able to fly circles around the French aircraft.

The Wrights had made this system of ropes and pulleys which connected rudder to twisting wing tips to a cradle under the pilot's body, the central focus of their patent on the airplane. When world motorcycle high speed record holder and engine designer Glenn Curtiss, with funding from Alexander Graham Bell and others, built and flew an airplane with performance as good as or better than the Wright Flyer, the Wrights sued for patent violation. The Curtiss planes, which used either small, separate wings near the wing tips or wingtip mounted triangular flaps (later to be called ailerons) and which relied on pilot operation of separate controls like today's stick and rudder system, were able to achieve the same turning performance as the Wrights Flyer. Curtiss, a much more flamboyant and public figure than either of the Wrights, quickly captured the attention and imagination of the American public, infuriating the Wrights who had shunned public attention while convincing themselves that no one else was capable of duplicating their aerial feats.

The decade long court battle between Curtiss and the Wright family over patent rights to devices capable of efficiently turning an airplane is credited by most historians as allowing European aviators and designers to forge far ahead of Americans. The Wrights were so absorbed with protecting their patent that they made no further efforts to improve the airplane and the threat of a Wright lawsuit kept all American airplane designers but Curtiss out of the business. Curtiss, whose lack of respect for caution had earlier enabled him to set the world motorized speed record on a motorcycle with a V-8 engine, with moral and financial support from Bell and Henry Ford and others, kept the patent suit in court through appeal after appeal and continued to build and sell airplanes. To get around the Wright patent, Curtiss, at one time built his aircraft without ailerons or other roll controls and then shipped them to nearby Canada where one of Bell's companies added the ailerons before the planes were shipped to customers in Europe! Meanwhile, Curtiss continued to experiment and innovate and it is no accident that when the first World War drew American participation it was Curtiss and not Wright aircraft that went to war. After the war it was the famed Curtiss "Jenny" that brought the "barnstorming" age of aviation to all America.

I hope the reader will pardon the above slip into historical fascination. By now some of you are asking what the heck all of this has to do with aircraft performance in turns? The facts are, however, that the first ten to fifteen years of American flight really were dominated by the airplane's ability to turn.

8.1 The Mechanics of a Turn

To keep the physics of our discussion as simple as possible, let's consider only turns at **constant radius in a horizontal plane**. This is the ideal turn with no loss or gain of altitude which every student pilot practices by flying in circles around some farmer's silo or other prominent landmark.

Our objectives in looking at turning performance will be to find things like the maximum rate of turn and the minimum turning radius and to determine the power or thrust needed to maintain such turns. We will begin by looking at two types of turns.

Today's airplanes, in general, make turns using the same techniques pioneered by the Wrights and improved by Curtiss; coordinated turns using rudder and aileron controls to combine roll and yaw. The primary exception would be found in some evasive turning maneuvers made by military aircraft and in the everyday turns of most student pilots!

Non-winged vehicles such as missiles, airships, and submarines still make turns like those of early French aviators and of Langley's "Aerodrome", using rudder and body or fuselage sideforce to generate a "skidding" turn. We will examine this technique before looking at the more sophisticated coordinated turn.

The acceleration in **any** turn of radius R is given by the following relation:

$$a_r = \frac{V^2}{R}.$$

This acceleration is directed radially inward toward the center of the circle and is properly termed the **centripetal acceleration**.

We can also consider the acceleration from the perspective of the rate of change of the “heading angle”, ψ , as shown in the figure below.

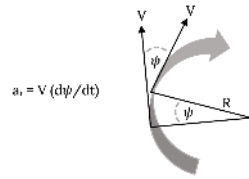

Figure 8.1: Angle of Turn

The “skid to turn” technique is illustrated below for a constant radius, horizontal turn. A rudder (or even vectored thrust) is used to angle the vehicle and the sideforce created by the flow over the yawed body creates the desired acceleration.

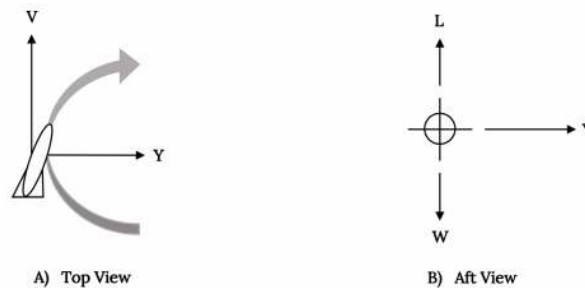

Figure 8.2: “Skid to Turn” Using Side Force

The equations of motion become

$$L - W = 0$$

$$Y = mV(d\psi/dt) = m(V^2/R)$$

For the skid turn examined above, the turning rate and radius depend on the amount of side force which can be generated on the body of the vehicle. Note that the lift (or buoyancy in the cases of submarines and airships) does not enter into the problem.

$$R = (WV^2)/(gY) , d\psi/dt = (gY)/(WV)$$

With the above relationships one can determine the radius and rate for a horizontal turn where body force, not wing lift, carries the vehicle through a turn. This is how non-winged rockets and missiles turn. Airplanes use a much more powerful force, the lift, to turn. By using the lift to provide the needed sideforce and to counteract the weight in a coordinated fashion an airplane can make a much more efficient turn than missiles or dirigibles.

Let’s look at the **coordinated turn**. In the ideal coordinated turn as illustrated in Figure 8.3, the aerodynamic lift is used to balance the weight such that horizontal flight is maintained and to provide a side force which produces the desired turning acceleration. No actual side force is generated on the fuselage of the aircraft. This type of turn requires the pilot to use the rudder and the ailerons and the throttle to give the ideal balance of bank angle and forces which will create a constant radius turn and maintain altitude.

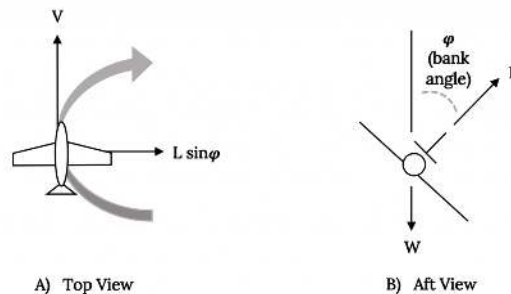

Figure 8.3: Coordinated Turn. Left: Top view. Right: Aft view.

If this turn is properly coordinated the resulting combined acceleration and gravitational force felt by both airplane and pilot will be directed “down” along the vertical axis of the aircraft and will be felt by the pilot as an increased force into the seat. The improperly coordinated will be felt as including a side force pushing the pilot left or right in the seat. These same forces act on the “ball” in the aircraft’s “turn-slip” indicator, moving the ball off center in an uncoordinated turn. We will look at the turn-slip indicator later.

If a turn is not coordinated several results may occur. The turning radius will not be constant and the airplane will either “skid” outward to a larger radius turn or “slip” inward to a smaller radius. There could also be a gain or loss of altitude.

In the coordinated turn, part of the lift produced by the wing is used to create the turning acceleration. The remainder of the lift must still counteract the weight to maintain horizontal flight.

We now find ourselves looking for the first time at a situation where lift is not equal to weight. In a coordinated turn the lift must be greater than the weight and we define a “load factor”, n , to account for this inequality.

$$L = nW \quad (8.1)$$

This load factor can then be related to the bank angle used in the turn, to the turn radius, and to the rate of turn. Returning to the vertical force balance equation we have

$$L \cos \varphi - W = nW \cos \varphi - W = 0 \quad (8.2)$$

which gives:

$$\cos \varphi = 1/n \quad (8.3)$$

Using the other equation of motion we can find the turn radius

$$R = (mV^2)/(L \sin \varphi) = (mV^2)/(nW \sin \varphi) = (V^2/ng)(1/\sin \varphi) \quad (8.4)$$

Knowing that the cosine of the bank angle is equal to $1/n$ we can find the value of the sine of the bank angle by constructing a right triangle

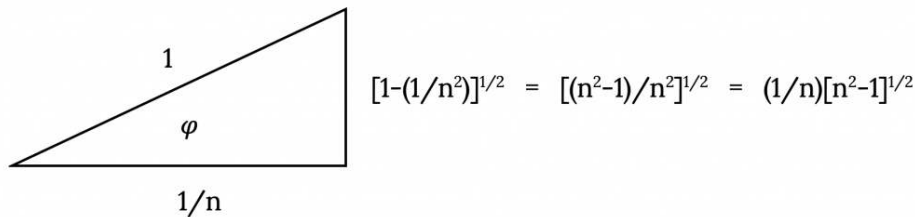

Figure 8.4: Trigonometric Relationship Between Turn Angle phi and Load Factor n

hence,

$$\sin \varphi = [(n^2 - 1) / n^2]^{1/2} \quad \text{and} \quad \tan \varphi = [n^2 - 1]^{1/2}$$

and the turning radius becomes

$$R = (V^2/g)\{1 / [n^2 - 1]^{1/2}\}.$$

In dealing with turns we must remember that lift is no longer equal to weight. The lift coefficient is then

$$C_L = L / (1/2\rho V^2 S) = (2nW) / (\rho V^2 S)$$

therefore

$$V^2 = (2nW) / (\rho S C_L)$$

The above allows us to write the turning radius in another manner,

$$R = [2W / (\rho g S C_L)] [n / (n^2 - 1)^{1/2}]$$

It should be noted here that if a small turning radius is desired a high load factor and lift coefficient are needed and low altitude will help. High wing loading (W/S) will also allow a tighter turn.

The rate of turn in a coordinated turn is

$$d\psi/dt = (L \sin \varphi) / (mV) = \{(nmg) / (mV)\} \sin \varphi = [ng/V] [(n^2 - 1)^{1/2} / n]$$

or

$$d\psi/dt = (g/V)[n^2 - 1]^{1/2}$$

Alternatively,

$$d\psi/dt = g \{[(\rho S C_L) / (2W)]^{1/2} [(n^2 - 1) / n]^{1/2}\}$$

The same factors which contribute to small turning radii give high rates of turn.

8.2 Load factor (n)

From the above equations it is obvious that the load factor plays an important role in turns. In straight and level flight the load factor, n , is 1. In maneuvers of any kind the load factor will be different than 1. In a turn such as those described it is obvious that n will exceed 1. The same is true in maneuvers such as “pull ups”.

The load factor is simply a function of the amount of lift needed to perform a given maneuver. If the required bank angle for a coordinated turn is 60° the load factor must equal 2. This means that the lift is equal to twice the weight of the aircraft and that the structure of the aircraft must be sufficient to carry that load. It also means that the pilot and passengers must be able to tolerate the loading imposed on them by this turn, a load which is forcing their body into their seat with an effect twice that of normal gravity. This “2g” load or acceleration is also forcing their blood from their heads to their feet and having other interesting effects on the human body.

If we look at the lift relation

$$L = n_{\max} W = C_{L\max} [1/2 \rho V^2 S]$$

we see that the maximum lift and therefore the maximum load factor that may be generated aerodynamically is a function of the maximum lift coefficient (stall conditions).

One must realize that the aircraft, or, more precisely, its wings, may be capable of generating far higher load factors than either the pilot and passengers or the aircraft structure may be able to tolerate. It is not hard to design aircraft which can tolerate far higher “g-loads” than the human body, even when the body is in a prone position in

a specially designed seat and uniform. Engineers in the industry will tell you that they could design far more agile fighters at much lower cost if the military didn't insist on having pilots in the cockpit!

All aircraft, from a Cessna 152 to the X-31, are designed to tolerate certain load factors. The aerobatic version of the Cessna 152 is certified to tolerate a higher load factor than the "commuter" version of that aircraft. An aerobatic aircraft must be designed for a load factor of 6.

The FAA also imposes certain flight restrictions on commercial aircraft based on passenger comfort. It is possible to do aerobatics in a Boeing 777 but most of the passengers wouldn't like it. Passenger carrying commercial flight is therefore normally restricted to "g-loads" of 1.5 or less even though the aircraft themselves are capable of much more.

8.3 The two-minute turn

General aviation pilots are usually familiar with the "standard rate" or "two-minute" turn. This turn, at a rate of three-degrees per second (0.05236 rad/sec), is used in maneuvers under controlled instrument flight conditions. To make such a turn the pilot uses an instrument called a "turn-slip" indicator. This instrument, illustrated below, consists of a gyroscope which is partially restrained and attached to a needle indicator, and a curved tube containing a ball in white kerosene. As the airplane turns, the gyroscope deflects the indicator needle as it attempts to remain fixed in orientation. The "precession" force of the gyroscope and the resulting needle displacement is proportional to the turn rate. The accuracy of this indication is not dependent on the degree to which the turn is coordinated. The ball in the curved tube will stay centered if the turn is coordinated while it will move to the side (right or left) if it is not coordinated. One of the sets of markings on the face of the instrument indicates a two minute turn.

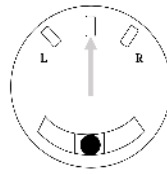

Figure 8.5: Turn-Slip Indicator

8.4 The Turn-Slip Indicator

To make a two-minute turn the pilot need only place the aircraft in a turn such that the needle is at the standard turn indication in the desired direction. To turn 90° the turn rate is maintained for 30 seconds, one minute for 180°, etc. The vertical speed indicator (rate of climb) is used to maintain altitude and the ball is kept centered to coordinate the turn.

Many pilots are taught, incorrectly, that the two-minute turn mark on the turn-slip indicator is an indication of a 15 degree bank angle, with the next mark being 30° and so on. Some pilots even refer to the turn-slip indicator as the "turn-bank" indicator when the instrument has absolutely no way to detect bank. It is possible, using a "cross control" technique, to turn the aircraft via yaw with no bank (much like a missile turns) and see that the instrument indicates the correct rate of turn even though there is no bank and, similarly, the aircraft may be placed in roll without turning and the indicator will remain centered.

Why would this error in flight instruction occur? The answer lies partly in the difficulty in eradicating longstanding lore and partly in the fact that, for a small general aviation trainer airplane, a coordinated two-minute turn does occur at about a 15 degree bank angle. Let's look at the numbers.

From our previous equations we have

$$\tan \phi = (V/g)d\psi/dt$$

Inserting fifteen degrees as the bank angle and a two minute turn rate (0.05236 rad/sec) gives a velocity of 165 ft/sec or 112 mph. This is indeed close to the speed at which such an airplane would fly in a turn. If we, however, look at a faster aircraft, lets say one that is operating at 350 miles per hour, and use the two-minute rate of turn we get a very different bank angle of 30 degrees!

Suppose you are a passenger in a Boeing 737 traveling at 600 mph and the pilot set up a two minute turn. This would give a bank angle of 55 degrees. It would also give a load factor of 1.75! This is higher than the FAA allows for airline operations. For this reason airliners use turn rates slower than the two minute turn in flight and only make two minute turns at low speeds, perhaps when operating in the "pattern" around airports.

8.5 Instantaneous versus sustained turn conditions

The previously derived relations will give the **instantaneous** turn rate and radius for a given set of flight conditions. In other words, for a given set of initial flight conditions we can determine the turn rate and radius, etc. Another question which must be asked is "Can the airplane sustain that turn rate?" The pilot may be able to, for example, place the plane in a 60 degree bank at 250 mph but may find that there is not enough engine thrust to hold that speed and bank angle while maintaining altitude.

✓ Example 8.1

For the airplane with the specifications below find the maximum turn rate and minimum radius of turn and the speeds at which they occur. Also determine if this turn can be sustained at sea level standard conditions.

$$W/S = 59.88 \text{ lb/ft}^2$$

$$S = 167 \text{ ft}^2$$

$$C_{L\max} = 1.5$$

$$n_{\max} = 6$$

$$C_{D0} = 0.018$$

$$K = 0.064$$

$$T_{\max} = 5000 \text{ lb}$$

The maximum turning rate is

$$d\psi/dt = g \left\{ (\rho S C_{L_{max}}) / (2W) \right\}^{1/2} \left[(n_{max}^2 - 1) / n_{max} \right]^{1/2}$$

$$= 0.424 \text{ rad/sec} = 24.29^\circ/\text{sec} .$$

The velocity for this turn rate is

$$V = [(2nW) / (\rho S C_{L_{max}})]^{1/2} = 448.6 \text{ ft/sec}$$

The minimum turning radius is

$$R_{min} = [2W / (\rho g S C_{L_{max}})] \left[n / (n^2 - 1)^{1/2} \right] = 1058 \text{ ft} = V / (d\psi/dt)$$

Now we must see if the plane has enough thrust to operate at these conditions. The drag coefficient at maximum lift coefficient is

$$C_D = 0.018 + 0.064 C_{L_{max}}^2 = 0.162 .$$

At the speed found above the drag is then

$$D = C_D (1/2 \rho V^2 S) = 6479 \text{ lb}$$

This drag exceeds the thrust available from the aircraft engine!

If the above aircraft enters a coordinated turn at the maximum turn rate it will quickly slow to a lower speed and turning rate with a larger turn radius or it will lose altitude.

8.6 The V-n or V-g Diagram

A plot which is sometimes used to examine the combination of aircraft structural and aerodynamic limitations related to load factor is the V-n or V-g diagram. This is a plot of load factor n versus velocity.

We know that when lift exceeds weight

$$L = nW = C_L (1/2 \rho V^2 S)$$

We know that one limit is imposed by stall

$$L = nW = C_{L_{max}} (1/2 \rho V^2 S)$$

Rearranging this we can write

$$n = 1/2 \rho V^2 C_{L_{max}} / (W/S)$$

and we can rearrange this as

$$V = [2nW / (\rho S C_{L_{max}})]^{1/2}$$

Plotting n versus V will then give a curve like that shown below.

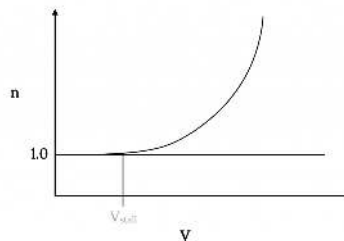

Figure 8.6: Stall Portion of a V-n Diagram (positive alpha only)

We can also consider negative load factors which will relate to “inverted” stall; ie, stall at negative angle of attack. At negative angle of attack, unless the wing is untwisted and constructed of symmetrical airfoil sections, $C_{L_{max}}$ will be different from that at positive angle of attack. This will give a different but similar curve below the axis. Combining this with the plot above gives the following plot.

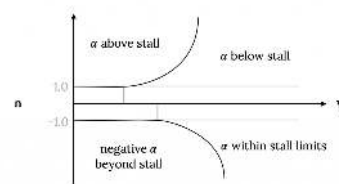

Figure 8.7: Complete Stall Portion of V-n Diagram

To the left of this curve is the post-stall flight region which, with the exception of high performance military aircraft, represents a out-of-bounds area for flight.

Other limits must also be considered. There will obviously be an upper speed limit such as that found earlier for straight and level flight. There will also be limits imposed by the structural design of the aircraft. Depending on the aircraft’s structural category (utility, aerobatic, etc.) it will be designed to structurally absorb load factors up to a given limit at positive angle of attack and another limit at negative angle of attack. Once these are defined, the complete V-n diagram denotes an operating envelope in terms of load factor limits.

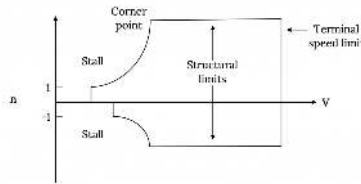

Figure 8.8: Complete V-n Diagram

The point where the structural limit line and the stall limit intersect is termed a “corner point”. The velocity at this point is limited by both maximum structural load factor and C_{Lmax} . The velocity at that point is

$$V_{corner} = [(2n_{max}W) / (\rho C_{Lmax} S)]^{1/2}$$

At speeds below the “corner velocity” it is impossible to structurally damage the airplane aerodynamically because the plane will stall before damage can occur. At speeds above this value it is possible to place the aircraft in a maneuver which will result in structural damage, provided the plane has sufficient thrust to reach that speed and load.

It is possible for a wind “gust” to cause loads which exceed the above limits. Such gusts may be part of what is referred to as wind shear and are common around thunderstorms or mountain ridges. Gusts can be in either the vertical or horizontal direction. The primary effect of a horizontal gust is to increase or decrease the likelihood of stall due to the change in speed relative to the wing. This is often the cause of wind shear accidents around airports where the aircraft is operating at near-stall conditions.

If a gust is vertical, we can look at its effect in terms of change of angle of attack. Suppose we have a vertical gust of magnitude w_g . Its effect on the angle of attack and C_L is seen below.

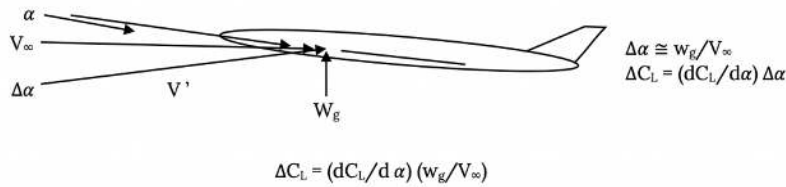

Figure 8.9: Effect of Gust Load on Lift Coefficient

so the change in lift is

$$\Delta L = \Delta C_L (1/2 \rho V_\infty^2 S) \cong 1/2 (dC_L/d\alpha) \rho S V_\infty w_g$$

Thus

$$\Delta n = \Delta L/W = (1/W) \frac{1}{2} (dC_L/d\alpha) \rho S V_\infty w_g$$

If, for example, an aircraft in straight and level flight encounters a vertical gust of magnitude w_g the new load factor is

$$n' = n + \Delta n = 1 + (1/W) \frac{1}{2} (dC_L/d\alpha) \rho S V_\infty w_g$$

(for straight and level flight $n = 1$)

The effect of the gust on the load factor is therefore amplified by the flight speed V . This effect can be plotted on the V-n diagram to see if it results in stall or structural failure.

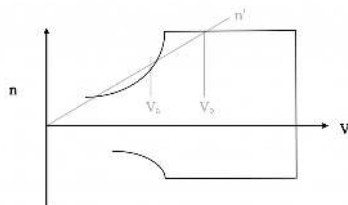

Figure 8.10: Gust Loading on V-n Diagram

For the case illustrated above, the gust will cause stall if it occurs at a flight speed below V_a and can cause structural failure if it occurs at speeds above V_b .

Homework 8

We wish to compare the performance of two different types of “General Aviation” aircraft; the popular Cessna Citation III business jet and the best all-around, four place, single engine, piston plane in the business, the Cessna 182. Approximate aerodynamic and performance characteristics are given in the table below:

Table 8.1: Aerodynamic and Performance Characteristics

	CITATION III	CESSNA 182
Wingspan	53.3 ft	35.8ft
Wing area	318 ft ²	174 ft ²
Normal gross weight	19,815 lb	2,950 lb
Total thrust at sea level	7300 lb	-----
Usable power at sea level	-----	230 hp
C _{D0}	0.02	0.025
Oswald Efficiency Factor (e)	0.81	0.80

1. Calculate and tabulate the thrust required (drag) versus V_e data for both aircraft and plot the results on the same graph [Figure 8.11]. Plot the sea level thrust available curves for both aircraft on the same graph [Figure 8.11].
2. Calculate the maximum velocity at sea level for both aircraft and compare with that indicated on the graph [Figure 8.11].

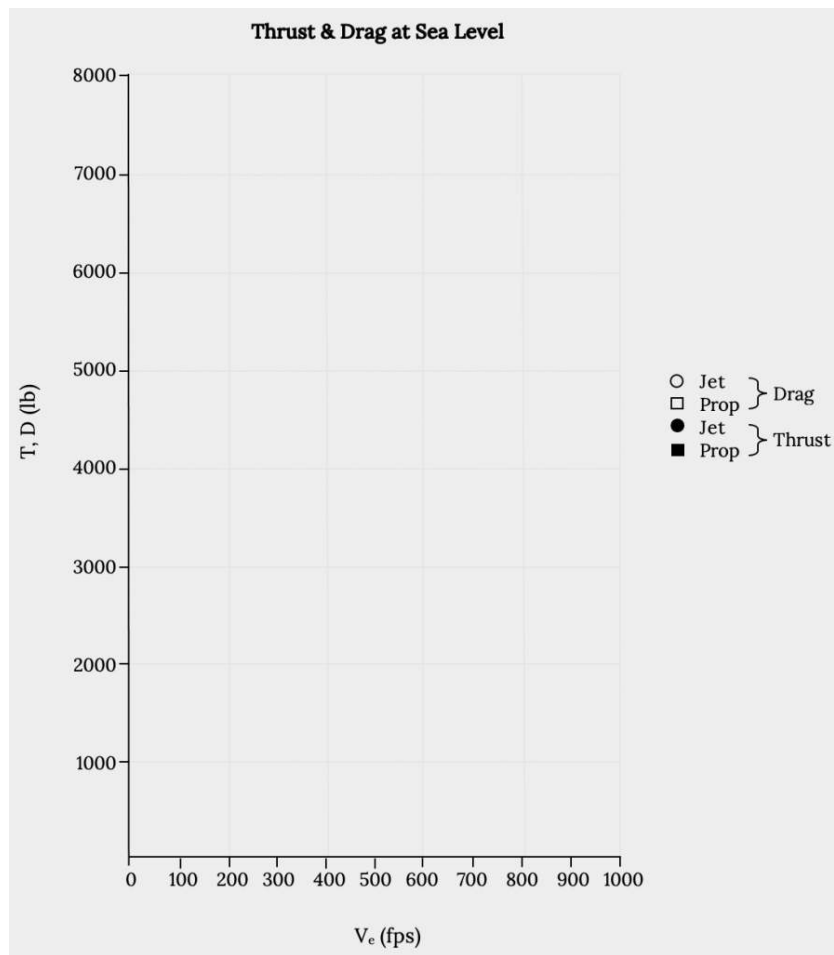

Figure 8.11: Thrust & Drag at Sea-Level

3. Calculate and tabulate the power required versus V_e data for both aircraft and plot each on a separate graph [Figures 8.12 and 8.13]. Plot the sea level power available on the same graphs.

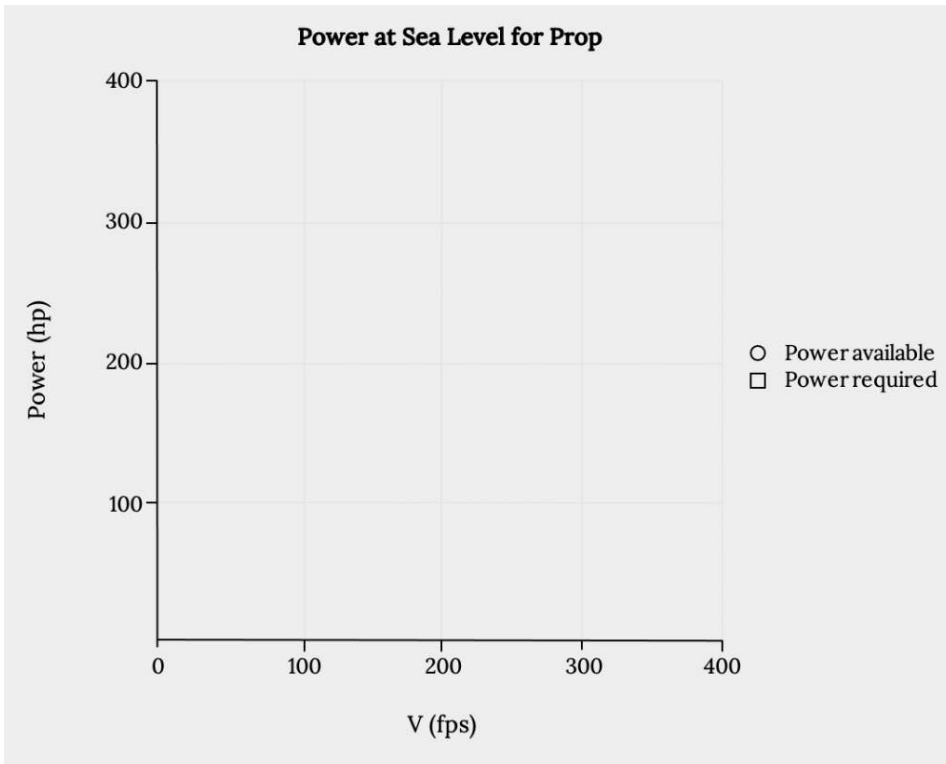
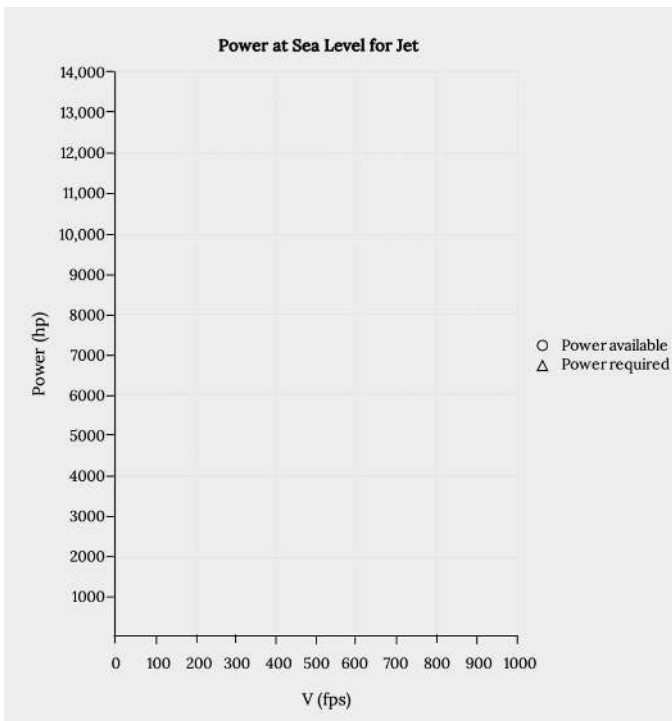
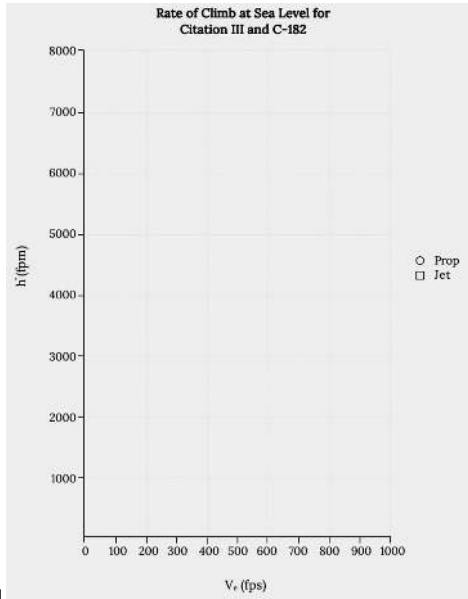

Figure 8.12: Power at Sea Level For Prop



8.13 Power at Sea Level for Jet

4. Calculate and tabulate the rate of climb (in ft/min) versus velocity data at sea level for both aircraft for normal gross weight and plot the data on the same graph [Figure



8.14].

Figure 8.14: Rate of Climb at Sea Level for Citation III and C-182

5. Calculate and tabulate the maximum rate of climb versus altitude data for both aircraft and plot it on the same graph. [Figure 8.15]. Determine the absolute ceilings of both aircraft.

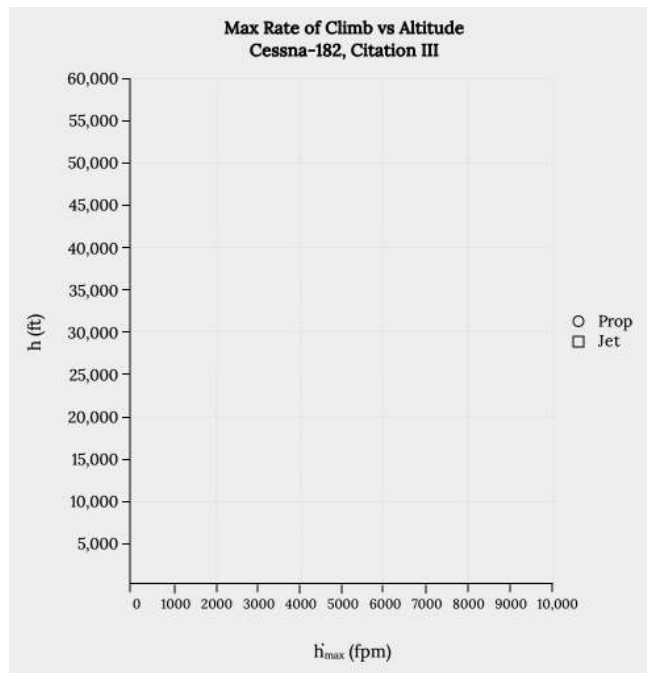

Figure 8.15: Max Rate of Climb vs Altitude Cessna-182, Citation III

6. Calculate the time required to climb from sea level to 20,000 ft for both aircraft. Assume that the curves (in 5) are close enough to linear to use a linear approximation for the calculation.

References

Figure 8.1: Kindred Grey (2021). "Angle of Turn." [CC BY 4.0](https://creativecommons.org/licenses/by/4.0/). Adapted from James F. Marchman (2004). [CC BY 4.0](https://creativecommons.org/licenses/by/4.0/). Available from <https://archive.org/details/8.1-updated>

Figure 8.2: Kindred Grey (2021). "'Skid to Turn" Using Side Force (a) Top View (b) Side View." [CC BY 4.0](https://creativecommons.org/licenses/by/4.0/). Adapted from James F. Marchman (2004). [CC BY 4.0](https://creativecommons.org/licenses/by/4.0/). Available from <https://archive.org/details/8.2-updated>

Figure 8.3: Kindred Grey (2021). "Coordinated Turn (a) Top View (b) Aft View." [CC BY 4.0](https://creativecommons.org/licenses/by/4.0/). Adapted from James F. Marchman (2004). [CC BY 4.0](https://creativecommons.org/licenses/by/4.0/). Available from <https://archive.org/details/8.3-updated>

Figure 8.4: Kindred Grey (2021). “Trigonometric Relationship Between Turn Angle ϕ and Load Factor n .” [CC BY 4.0](#). Adapted from James F. Marchman (2004). [CC BY 4.0](#). Available from https://archive.org/details/8.4_20210805

Figure 8.5: Kindred Grey (2021). “Turn-Slip Indicator.” [CC BY 4.0](#). Adapted from James F. Marchman (2004). [CC BY 4.0](#). Available from <https://archive.org/details/8.5-updated>

Figure 8.6: Kindred Grey (2021). “Stall Portion of a V-n Diagram (positive α only).” [CC BY 4.0](#). Adapted from James F. Marchman (2004). [CC BY 4.0](#). Available from <https://archive.org/details/8.6-updated>

Figure 8.7: Kindred Grey (2021). “Complete stall Portion of V-n Diagram.” [CC BY 4.0](#). Adapted from James F. Marchman (2004). [CC BY 4.0](#). Available from <https://archive.org/details/8.7-updated>

Figure 8.8: Kindred Grey (2021). “Complete V-n Diagram.” [CC BY 4.0](#). Adapted from James F. Marchman (2004). [CC BY 4.0](#). Available from <https://archive.org/details/8.8-updated>

Figure 8.9: Kindred Grey (2021). “Effect of Gust Load on Lift Coefficient.” [CC BY 4.0](#). Adapted from James F. Marchman (2004). [CC BY 4.0](#). Available from <https://archive.org/details/8.9-updated>

Figure 8.10: Kindred Grey (2021). “Gust Loading on V-n Diagram.” [CC BY 4.0](#). Adapted from James F. Marchman (2004). [CC BY 4.0](#). Available from <https://archive.org/details/8.10-new>

Figure 8.11: Kindred Grey (2021). “Thrust & Drag at Sea-Level.” [CC BY 4.0](#). Adapted from James F. Marchman (2004). [CC BY 4.0](#). Available from <https://archive.org/details/hw-8-part-1>

Figure 8.12: Kindred Grey (2021). “Power at Sea Level For Prop.” [CC BY 4.0](#). Adapted from James F. Marchman (2004). [CC BY 4.0](#). Available from <https://archive.org/details/hw-8-part-2>

Figure 8.13: Kindred Grey (2021). “Power at Sea Level For Jet.” [CC BY 4.0](#). Adapted from James F. Marchman (2004). [CC BY 4.0](#). Available from <https://archive.org/details/hw-8-part-3>

Figure 8.14: Kindred Grey (2021). “Rate of Climb at Sea Level for Citation III and C-182.” [CC BY 4.0](#). Adapted from James F. Marchman (2004). [CC BY 4.0](#). Available from <https://archive.org/details/hw-8-part-4>

Figure 8.15: Kindred Grey (2021). “Max Rate of Climb vs Altitude Cessna-182, Citation III.” [CC BY 4.0](#). Adapted from James F. Marchman (2004). [CC BY 4.0](#). Available from <https://archive.org/details/hw-8-part-5>

<!-- pb_fixme --><!-- pb_fixme -->

This page titled [8: Accelerated Performance - Turns](#) is shared under a [CC BY 4.0](#) license and was authored, remixed, and/or curated by [James F. Marchman](#) (Virginia Tech Libraries' Open Education Initiative) via [source content](#) that was edited to the style and standards of the LibreTexts platform.

9: The Role of Performance in Aircraft Design - Constraint Analysis

Chapter 9. The Role of Performance in Aircraft Design: Constraint Analysis

Introduction

In the proceeding chapters we have looked at many aspects of basic aircraft performance. These included takeoff and landing, turns, straight and level flight in cruise, and climb. If we were to look at the relationships we found for any of these we could see how we might design an airplane to best accomplish the task at hand. In other words, if we wanted to design an aircraft that could takeoff and land in a very short distance we can look at the takeoff and landing distance equations and identify the factors that would minimize these distances. To takeoff in a short distance we might want a high maximum lift coefficient to get a low takeoff speed, a large wing area to give a lot of lift at low speed, and a lot of thrust to accelerate to takeoff distance in as short a ground run as possible. To land in a short distance we might want to also design a plane with a large wing and high maximum lift coefficient but now the thrust isn't as important as the amount of braking friction available unless it is reverse thrust that we are talking about.

Of course there are limits to be considered. High thrust will minimize the takeoff ground run but once thrust becomes as high as the weight of the plane we might as well take off vertically! And a big wing area gives us high drag along with high lift. Nonetheless, we can see that three parameters; thrust, weight, and wing area, are important factors to consider in takeoff.

We would find, if we looked at the equations we derived for the other types of flight mentioned above that these same three parameters pop up everywhere. The only problem is that we would find that their relationships in cruise aren't necessarily the same as they are in takeoff and landing. And they may be different still in climb.

If we want an airplane that only does one thing well we need only look at that one thing. If, for example, we went all out to create a plane that could takeoff in a very short distance and then look at its performance in straight and level cruise we would probably find that it isn't very good. And its climbing performance may be even worse!

This isn't really much different from designing any other product that is capable of more than one task. A car can be designed to go really fast or to get really good gas mileage, but probably not both. Car tires can be designed to have high traction in mud and snow or to give great mileage at highway speeds but any attempt to design an "all weather touring" tire will result in a compromise with less traction than a mud and snow tire and poorer performance at high speeds than the high speed highway tire design.

The question with the design of an airplane as with a car or a tire, is how do we arrive at the best compromise that will result in a good all around design while still being better than average in one or two desired areas?

One way to approach this would be to go back to the equations in earlier chapters and iterate among them, trying to find wing areas, weights, and engine sizes that would accomplish our design objectives. We might start with cruise since a certain minimum range is often a design objective. We know that in cruise since lift must equal weight, we can select a design value of cruise lift coefficient (commonly around 0.2 to 0.3) and a desired cruise speed and altitude and solve for the needed wing area.

$$S = 2W/(\rho V^2 C_L)$$

If our desire is to look at an optimum range we might want to find the ratio of lift to drag that will maximize range (for example, for a propeller driven plane R_{\max} occurs with flight at $[L/D]_{\max}$ or at minimum drag conditions). Finding this value of drag would set the thrust we need for cruise. Within all this we could look at the effects of aspect ratio and Oswald's efficiency factor to find how wing planform shape will affect our results.

In this manner, we can find values of weight, wing area, and thrust that match our desired cruise capability. However, these may not represent the best combination of these parameters if another of our goals is to achieve a certain climb rate.

Another factor to consider would be the desired maximum speed at the cruise altitude. This can be put into the drag equation with the numbers found above to get the thrust or power needed to reach that maximum speed.

The cruise based calculations mentioned above would give us valuable design information for our airplane based on a desired cruise speed and altitude for a design weight and would tell us the wing area and thrust needed for that cruise condition and the thrust needed to cruise at a desired maximum speed. It would not, however tell us if this would result in a good ability to climb or the ability to takeoff and land in a reasonable distance. We would also need to look at these requirements and our design objectives.

To see if we can climb at the desired rate over a reasonable range of altitudes we would need to look at the climb relationship:

$$dh/dt = [P_{avail} - P_{req}] / W$$

This would give us another value of thrust needed to reach the target rate of climb for a given weight and, since the equation contains power required, which is drag times speed, the wing area would also be a factor.

Finally, we would need to look at the takeoff and landing relationships and at our target values for ground run or for the total takeoff or landing distance. These relationships also involve thrust, weight, and wing area.

The essence of all this is that if we even have only three primary design objectives; a cruise specification, a climb requirement, and a takeoff or landing constraint, we can end up with three different values for wing area and thrust required for a given aircraft weight. We would then have to decide which of these three requirements was most important and which was least important and then start varying design parameters in an iterative manner until we got all three objectives to result in the same weight, wing area, and engine thrust.

This process would become even more cumbersome as we added other design objectives such as a minimum turning radius or a minimum stall speed.

The question is; is there some way to analyze all of these at the same time and come to a decision about optimum or reasonable compromise values of weight, wing area, and engine thrust without having to go through iteration after iteration? Fortunately, the answer is yes. The method normally used is called “**constraint analysis**”.

9.1 Constraint Analysis

Constraint analysis is essentially a way to look at aircraft weight, wing area, and engine thrust for various phases of flight and come to a decision about meaningful starting values of all three parameters for a given set of design objectives. It does this by looking at two important ratios, the thrust-to-weight ratio (T/W), the wing loading or ratio of weight-to-planform area (W/S). Or in some cases the power-to-weight ratio (P/W) is used instead of T/W. These two ratios are both very reflective of the design philosophy and objectives of any particular airplane.

As one of my students once put it, the thrust-to-weight ratio (T/W) is a measure of how much of a rocket your plane is. The more efficient a plane is in things like cruise the lower its value of T/W. The limit is a sailplane with T/W = 0 and at the other extreme we have fighter aircraft where T/W approaches unity. If T/W = 1.0 or greater we need no wing. The vehicle can get into the air with no lift at all. The value of T/W will depend on the desired flight speed, the wing area, and the efficiency (L/D) of the wing. In cruise where lift = weight and thrust = drag, $T/W = 1 / [L/D]$, meaning that the high value of L/D that is needed for a large range goes hand in hand with a low thrust-to-weight ratio.

The other parameter, W/S, or wing loading, is also generally low for sailplanes and high for fighters. Wing loading for sailplanes is usually in the range of 5-8 pounds per square foot, around 17 lb/ft² for general aviation planes, and over 100 lb/ft² for fighters. This ratio is a measure of aerodynamic efficiency as well as a measure of the way the structure is designed.

These two ratios are tied together in aircraft performance through the same power relationship that we looked at when we first examined climb and glide.

9.2 Specific Excess Power

In an earlier chapter on climb and glide we looked at something called *specific excess power* and defined it as:

$$P_s = [P_{avail} - P_{req}] / W = [(T - D)V] / W$$

We may, hopefully, remember using this relationship to find the rate of climb but we may not recall that it was only the correct rate of climb in a special case, where speed (V) was constant; i.e., the *static rate of climb*:

$$[dh/dt]_{static} = [(T - D)V] / W$$

If we go back to that earlier chapter we will find that in a more general relationship we had:

$$P_s = [P_{avail} - P_{req}] / W = [(T - D)V] / W = [dh/dt] + (V/g)(dV/dt).$$

In other words, only when velocity (V) is constant is this relationship strictly equal to the rate of climb.

In reality, the specific excess power relationship tells us how the excess engine power, $P_{\text{avail}} - P_{\text{req}}$, can be used to increase the aircraft's potential energy (climb) or its kinetic energy (speed). In other words this equation is really an energy balance. Power required is the power needed to maintain straight and level flight, i.e., to overcome drag and to go fast enough to give enough lift to equal the weight. If the engine is capable of producing more power than the power required, that *excess* power can be used to make the plane accelerate to a faster speed (increasing kinetic energy) or to climb to a higher altitude (increasing potential energy), or to give some combination of both. It can tell us how much speed we can gain by descending to a lower altitude, converting potential energy to kinetic energy, or how we can perhaps climb above the static ceiling of the aircraft by converting excess speed (kinetic energy) into extra altitude (potential energy).

In essence this is a pretty powerful relationship and it can be used to analyze many flight situations and to determine an airplane's performance capabilities. Let's look at how the equation can be rearranged to help us examine the performance needs in various types of flight.

Rearranging the equation we have:

$$(T/W)V = (D/W)V + dh/dt + (V/g)(dV/dt)$$

Now we can expand the first term on the right hand side by realizing that

$$D = (C_{D0} + kC_L^2) \frac{1}{2} \rho V^2 S.$$

Substituting this for drag in the equation and dividing the entire equation by V we can get:

$$(T/W) = [(C_{D0} + kC_L^2) \frac{1}{2} \rho V^2 S] / W + (1/V)dh/dt + (1/g)(dV/dt)$$

Now, to simplify things a little we are going to use a common substitution for the dynamic pressure:

$$q = \frac{1}{2} \rho V^2 .$$

We will also define the lift coefficient in terms of lift and weight using the most general form where in a turn or other maneuver lift may be equal to the load factor n times the weight.

$$C_L = L / qS = nW / qS$$

Putting all of this together will give:

$$T/W = (qC_{D0})/(W/S) + (kn^2/q)(W/S) + (1/V)dh/dt + (1/g)dV/dt$$

In the equation above we have a very general performance equation that can deal with changes in both speed and altitude and we find that these changes are functions of the thrust-to-weight ratio, T/W , and the wing loading W/S . Note that just as the drag equation is a function of both V and $1/V$, this is a function of both W/S and $1/(W/S)$.

9.3 Straight and level flight

We can use the above relationship to make plots of the thrust-to-weight ratio versus the wing loading for various types of flight. If, for example, we want to look at conditions for straight and level flight we can simplify the equation knowing that:

Straight and level flight: $n = 1$, $dh/dt = 0$, $dV/dt = 0$, giving:

$$T/W = (qC_{D0})/(W/S) + (k/q)(W/S)$$

So for a given estimate of our design's profile drag coefficient, aspect ratio, and Oswald efficiency factor [$k = 1/(\pi A R e)$] we can plot T/W versus W/S for any selected altitude (density) and cruise speed.

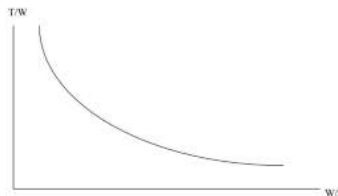

Figure 9.1: Inverse Relationship between Thrust to Weight Ratio and Weight to Surface Area Ratio

We could get a different curve for different cruise speeds and altitudes but at any given combination of these this will tell us all the combinations of thrust-to-weight values and wing loadings that will allow straight and level flight at that altitude and speed.

In understanding what this really tells us we perhaps need to step back and look at the same situation another way. In straight and level flight we know:

$$L = W = qSC_L$$

$$\text{and } T = D = qS(C_{D0} + kC_L^2)$$

And if we simply combine these two equations we will get the same relationship we plotted above.

$$T/W = (qC_{D0})/(W/S) + (k/q)(W/S)$$

Hence, what we have done through the specific excess power relationship is nothing but a different way to get a familiar result. We just end up writing that result in a different form, in terms of the thrust-to-weight ratio and the wing loading.

We need to note that to make the plot above we had to choose a cruise speed. We need to keep in mind that there are limits to that cruise speed. We can't fly straight and level at speeds below the stall speed or above the maximum speed where the drag equals the maximum thrust from the engine. We could put these limits on the same plot if we wish. For example, let's look at stall.

$$\text{At stall } V_{\text{stall}} = [2W/(\rho SC_{L\text{max}})]^{1/2}$$

$$\text{And this can be written } [W/S] = \frac{1}{2} \rho V_{\text{stall}}^2 C_{L\text{max}}$$

On the plot above this would be a vertical line, looking something like this

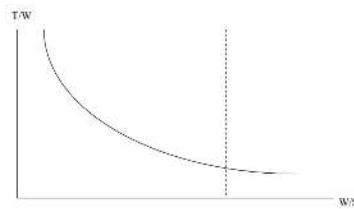

Figure 9.2: Stall Cutoff for Cap W over cap S values

Here we should note that the space to the right of the dashed line for stall is “out of bounds” since to fly here would require a higher maximum lift coefficient.

9.4 Climb

We could return to the reorganized excess power relationship

$$T/W = (qC_{D0})/(W/S) + (kn^2/q)(W/S) + (1/V)dh/dt + (1/g)dV/dt$$

and look at steady state climb. For climb at constant speed $dV/dt = 0$ and our equation becomes

$$T/W = (qC_{D0})/(W/S) + (kn^2/q)(W/S) + (1/V)dh/dt$$

and we can plot T/W versus W/S just as we did in the cruise case, this time specifying a desired rate of climb along with the flight speed and other parameters. Doing this will add another curve to our plot and it might look like the figure below.

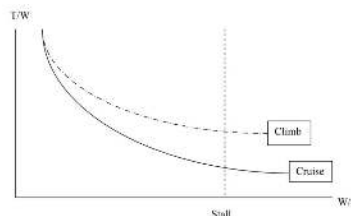

Figure 9.3: Effects of a Desired Climb Rate on Aircraft Design Space

This addition to the plot tells us the obvious in a way. It says that we need a higher thrust-to-weight ratio to climb than to fly straight and level.

Each plot of the specific power equation that we add to this gives us a better definition of our “design space”. It tells us that to make the airplane do what we want it to do we are restricted to certain combinations of T/W and W/S .

9.4.1 Caution

It should be noted that in plotting curves for cruise and climb a flight speed must be selected for each. It is, for example, a common mistake for students to look at the performance goals for an aircraft design and just plug in the numbers given without thinking about them. Design goals might include a maximum speed in cruise of 400 mph and a maximum range goal of 800 miles, however these do not occur at the same flight conditions. Just as a car cannot get its best gas mileage when the car is moving at top speed, an airplane isn't going to get maximum range at its top cruise speed. In fact, the equations used to find the maximum range for either a jet or a prop aircraft assume flight at very low speeds, speeds that one would never really use in cruise unless desperate to extend range in some emergency situation. When plotting the cruise curve in a constraint analysis plot it should be assumed that the aircraft is cruising at a desired “normal” cruise speed, which will be neither the top speed at that altitude nor the speed for maximum range. As an example, most piston engine aircraft will cruise at an engine power setting somewhere between 55% and 75% of maximum engine power. On the other hand, the climb curve should be plotted for optimum conditions; i.e., maximum rate of climb (minimum power required conditions for a prop aircraft) since that is the design target in climb.

9.5 Altitude effects

Obviously altitude is a factor in plotting these curves. The cruise curve will normally be plotted at the desired design cruise altitude. The climb curve would probably be plotted at sea level conditions since that is where the target maximum rate of climb is normally specified. This presents somewhat of a problem since we are plotting the relationships in terms of thrust and weight and thrust is a function of altitude while weight is undoubtedly less in cruise than at takeoff and initial climb-out. One way to resolve this issue is to write our equations in terms of ratios of thrust at altitude divided by thrust at sea level and weight at altitude divided by weight at takeoff.

$$T_{alt} / T_{sl} \text{ and } W_{alt} / W_{TO} .$$

Going back to our main equation:

$$T/W = (qC_{D0})/(W/S) + (kn^2/q)(W/S) + (1/V)dh/dt + (1/g)dV/dt ,$$

we rewrite this in terms of the ratios above to allow us to make our constraint analysis plots functions of T_{SL} and W_{TO} .

$$T_{SL} / W_{TO} = [(W_{alt}/W_{TO}) / (T_{alt}/T_{SL})] \{ [q/(W_{alt}/W_{SL})](C_{D0})/(W_{TO}/S) + (kn^2/q)(W_{TO}/S)(W_{alt}/W_{TO}) + (1/V)dh/dt + (1/g)dV/dt \} .$$

Some references give these ratios, which have been italicized above, symbols such as α and β to make the equation look simpler.

Note that the thrust ratio above is normally just the ratio of density since it is normally assumed that

$$T_{alt} / T_{sl} = \rho_{alt} / \rho_{SL} .$$

9.6 Other Design Objectives Including Take-off

What other design objectives can be added to the constraint analysis plot to further define our design space? One that is fairly easy to deal with is turning.

Often a set of design objectives will include a minimum turn radius or minimum turn rate. If we assume a coordinated turn we find that once again the last two terms in the constraint analysis relationship go to zero since a coordinated turn is made at constant altitude and airspeed. All we need to do is go to the turn equations and find the desired airspeed and load factor (n), put these into the equation and plot it. Normally we would look at turns at sea level conditions and at takeoff weight. This would give a curve that looks similar to the plots for cruise and climb.

The plot that will be different from all of these is that for takeoff. The takeoff equation seen in an earlier chapter is somewhat complex because takeoff ground distances depend on many things, from drag coefficients to ground friction.

$$S_{TO} = (1/2B) \ln [A / (A - BV_{TO}^2)]$$

where $A = g[(T_0/W) - \mu]$

and $B = (g/W) [\frac{1}{2} \rho S(C_D - \mu C_{Lg}) + a]$.

It should be recalled that C_{Lg} is the value of lift coefficient during the ground roll, not at takeoff, and its value is $\mu/2k$ for the theoretically minimum ground run. The last parameter in the “B” equation above is “a”, a term that appears in the thrust equation:

$$T = T_0 - aV^2,$$

a relationship that comes from the momentum equation where T_0 is the “static thrust” or the thrust when the airplane is standing still.

It can be noted that in the A and B terms respectively we have the thrust-to-weight ratio and the inverse of the wing loading (W/S); hence, for a given set of takeoff parameters and a desired ground run distance (S_{TO}) a plot can be made of T/W versus W/S. This relationship proves to be a little messy with both ratios buried in a natural log term and the wing loading in a separate term. An iterative solution may be necessary.

An alternative approach often proposed in books on aircraft design is based on statistical takeoff data collected on different types of aircraft. The figure below (Raymer, 1992) is based on a method commonly used in industry.

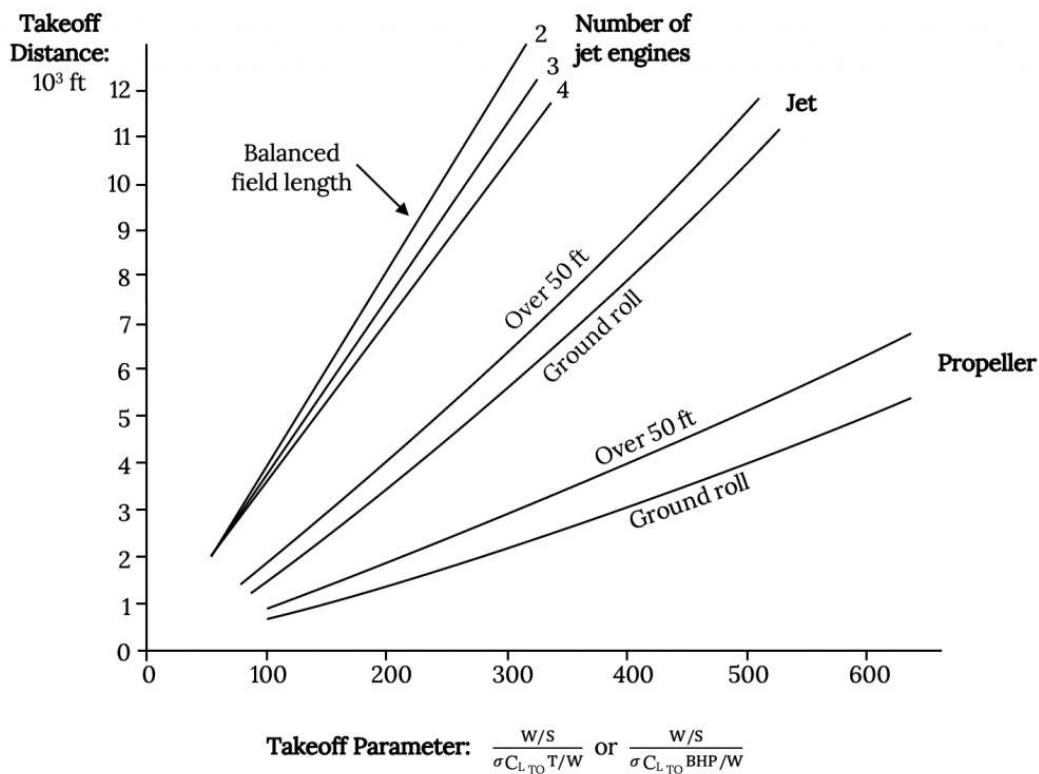

Figure 9.4: Effect of Aircraft Parameters on Takeoff Distance

In this approach a “Take-Off-Parameter”, TOP, is proposed to be a function of W/S, T/W, $C_{L_{TO}}$, and the density ratio sigma (σ) where:

$$W/S = (TOP)\sigma C_{L_{TO}}(T/W). [\sigma = \rho_{alt}/\rho_{SL}]$$

The value of “TOP” is found from the chart above. One finds the desired takeoff distance in feet on the vertical axis and projects over to the plot for the type of aircraft desired, then drops a vertical line to the TOP axis to find a value for that term. Once the value of TOP has been found the relationship above is plotted to give a straight line from the origin of the constraint analysis graph.

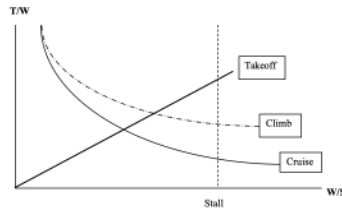

Figure 9.5: Effect of Desired Takeoff Characteristics on Aircraft Design Space

Two things should be noted at this point. First is that the figure from Raymer on the preceding page has two types of plots on it, one for ground run only and the other for ground run plus the distance required to clear a 50 ft obstacle. Either can be used depending on the performance parameter which is most important to meeting the design specifications. The second is that the takeoff parameter (TOP) defined for propeller aircraft is based on power requirements (specifically, horsepower requirements) rather than thrust. For the prop aircraft Raymer defines TOP as follows:

$$W/S = (TOP)\sigma C_{LTO}(hp/W).$$

It should be noted here that it is often common when conducting a constraint analysis for a propeller type aircraft to plot the power-to-weight ratio versus wing loading rather than using the thrust-to-weight ratio. This can be done fairly easily by going back to the constraint analysis equations and substituting P/V everywhere that a thrust term appears.

9.7 Landing

In reality, the landing distance is pretty much determined by the stall speed (the plane must touch down at a speed higher than stall speed, often about $1.2 V_{Stall}$) and the glide slope (where obstacle clearance is part of the defined target distance). Again it is common for aircraft design texts to propose approximate or semi-empirical relationships to describe this and those relationships show landing distance to depend only on the wing loading. This makes sense when one realizes that, unless reverse thrust is used in the landing ground run, thrust does not play a major role in landing. Raymer proposed the relationship below:

$$S_{\text{landing}} = 80(W/S)[1/(\sigma C_{Lmax})] + S_a$$

where

$S_a = 1000$ for an airliner with a 3 degree glideslope

600 for a general aviation type power off approach

450 for a STOL 7 degree glideslope

Raymer also suggests multiplying the first term on the right in the distance equation above by 0.66 if thrust reversers are to be used and by 1.67 when accounting for the safety margin required for commercial aircraft operating under FAR part 25.

Note here that the weight in the equation is the *landing weight* but that in calculating this landing distance for design purposes the takeoff weight is usually used for general aviation aircraft and trainers and is assumed to be 0.85 times the takeoff weight for jet transports.

The relationship above, since it does not depend on the thrust, will plot on our constraint analysis chart as a vertical line in much the same way the stall case did, but it will be just to the left of the stall line.

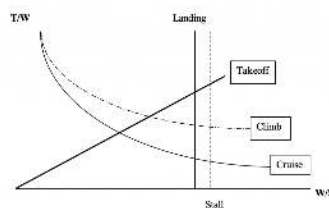

Figure 9.6: Effect of Desired Landing Characteristics on Aircraft Design Space

9.8 Optimum design points

In this final plot the space above the climb and takeoff curves and to the left of the landing line is our acceptable design space. Any combination of W/S and T/W within that space will meet our design goals. What we want, however, is the “best” combination of

these parameters for our design goals. The optimum will be found at the intersections of these curves. In the figure above this will be either where the takeoff and climb curves intersect or where the takeoff and landing curves intersect.

By “optimum” we mean that we are looking for the minimum thrust-to-weight ratio that will enable the airplane to meet its performance goals and we would like to have the highest possible wing loading. The desire for minimum thrust is obvious, based on the need to minimize fuel consumption and engine cost. The goal of maximum wing loading may not be as obvious to the novice designer but this means the wing area is kept to a minimum which gives lower drag. It also gives a better “ride” to the airplane passengers. As wing loading increases the effects of turbulence and gusts in flight are minimized, smoothing out the “bumps” in flight.

9.9 The design process

Constraint analysis is an important element in a larger process called aircraft design. There are many good textbooks available on aircraft design and the Raymer text referenced earlier is one of the best. Another good text that combines an examination of the design process with a look at several design case studies is *Aircraft Design Projects for Engineering Students*, by Jenkinson and Marchman, published by the AIAA.

The design process usually begins with a set of design objectives such as these we have examined, a desired range, payload weight, rate of climb, takeoff and landing distances, top speed, ceiling, etc. The first step in the process is usually to look for what are called “comparator” aircraft, existing or past aircraft that can meet most or all of our design objectives. This data can give us a place to start by suggesting starting values of things like takeoff weight, wing area, aspect ratio, etc. that can be used in the constraint analysis equations above. These are then plotted to find “optimum” values of wing loading and thrust-to-weight ratio.

The constraint analysis may be performed several times, looking at the effects of varying things like wing aspect ratio on the outcome. The analysis may suggest that some of the “constraints” (i.e., the performance targets) need to be relaxed. What can be gained by accepting a lower cruise speed or a longer takeoff distance. We might find, for example, that by accepting an additional 500 feet in our takeoff ground run we can get by with a significantly smaller engine.

Design is a process of compromise and no one design is ever best at everything. But through good use of things like constraint analysis methods we can turn those compromises into optimum solutions.

Acknowledgment: Thanks to Dustin Grissom for reviewing the above and developing examples to go with it.

Homework 9

Looking again at the aircraft in Homework 8 with some additional information:

Cessna 182	Cessna Citation III
$b = 35.8 \text{ ft}$	$b = 53.3 \text{ ft}$
$S = 174 \text{ ft}^2$	$S = 318 \text{ ft}^2$
$W_{\text{max}} = 2950 \text{ lb}$	$W_{\text{max}} = 19,815 \text{ lb}$
Fuel = 65 gal (@ 6 lb/gal)	Fuel = 1119 gal (@ 6.67 lb/gal)
Single engine 230 hp at SL	2 engines with 3650 lb thrust each at SL
$\eta_p = 0.8$	
$\gamma_p = 0.45 \text{ lb/hp-hr}$	$\gamma_T = 0.6 \text{ lb/lb_thrust-hr}$
$C_{D0} = 0.025$	$C_{D0} = 0.02$
$e = 0.8$	$e = 0.81$

1. Find the maximum range and the maximum endurance for both aircraft.
 - a. What altitude gives the best range for the C-182? Do you think this is a reasonable speed for flight?
 - b. What altitude gives the best endurance for the C-182? Is this a reasonable flight speed?

- c. Endurance for the C-182 can be found two ways (constant altitude or constant velocity). Which gives the best endurance?
2. Find the range for the C-182 assuming the flight starts at 150 mph and an altitude of 7500 feet and stays at constant angle of attack.
3. How sensitive is the maximum range for the Cessna 182 to aspect ratio and the Oswald efficiency factor, i.e. to the wing planform shape? To answer this, plot range versus aspect ratio using $e = 0.8$ and varying AR from 4 through 10, and plot range versus e for an aspect ratio of 7.366 with e varying from 0.6 through 1.0.

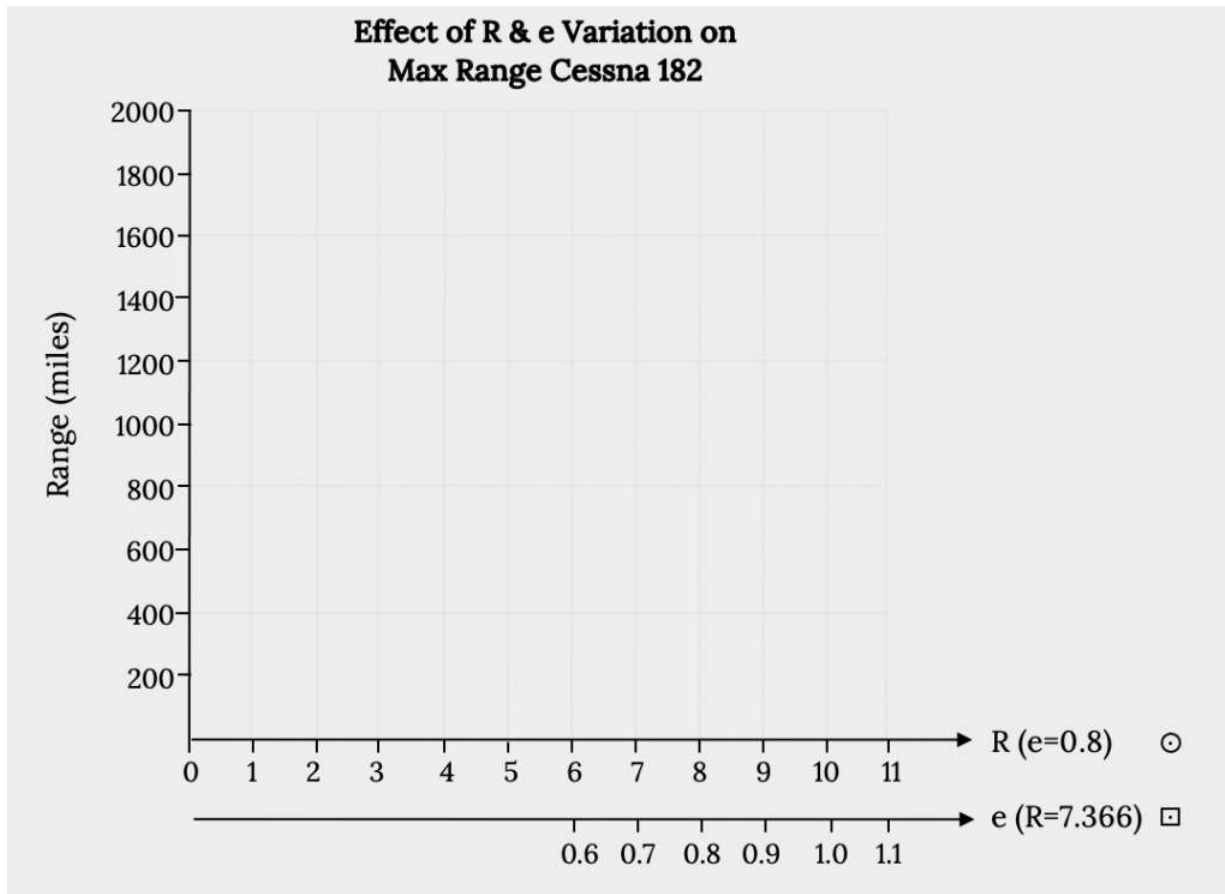

Figure 9.7: Effect of R & e Variation on max Range Cessna 182

References

Raymer, Daniel P. (1992). *Aircraft Design: A Conceptual Approach*, AIAA, Washington, DC.

Figure 9.1: James F. Marchman (2004). "Inverse Relationship between Thrust to Weight Ratio and Weight to Surface Area Ratio." [CC BY 4.0](#).

Figure 9.2: James F. Marchman (2004). "Stall Cutoff for cap W over cap S values." [CC BY 4.0](#).

Figure 9.3: James F. Marchman (2004). "Effects of a Desired Climb Rate on Aircraft Design Space." [CC BY 4.0](#).

Figure 9.4: Kindred Grey (2021). "Effect of Aircraft Parameters on Takeoff Distance." [CC BY 4.0](#). Adapted from Raymer, Daniel P. (1992). *Aircraft Design: A Conceptual Approach*, AIAA, Washington, DC. Available from https://archive.org/details/9.4_20210805

Figure 9.5: James F. Marchman (2004). "Effect of Desired Takeoff Characteristics on Aircraft Design Space." [CC BY 4.0](#).

Figure 9.6: James F. Marchman (2004). "Effect of Desired Landing Characteristics on Aircraft Design Space." [CC BY 4.0](#).

Figure 9.7: Kindred Grey (2021). "Effect of R & e Variation on max Range Cessna 182." [CC BY 4.0](#). Adapted from James F. Marchman (2004). [CC BY 4.0](#). Available from https://archive.org/details/hw-9_20210805

<!-- pb_fixme --><!-- pb_fixme -->

This page titled [9: The Role of Performance in Aircraft Design - Constraint Analysis](#) is shared under a [CC BY 4.0](#) license and was authored, remixed, and/or curated by [James F. Marchman](#) (Virginia Tech Libraries' Open Education Initiative) via [source content](#) that was edited to the style and standards of the LibreTexts platform.

10: Appendix - Airfoil Data

Appendix A: Airfoil Data

In Chapter 3 of this text we discussed many of the aspects of airfoil design as well as the NACA designations for several series of airfoils. Lift, drag, and pitching moment data for hundreds of such airfoil shapes was determined in wind tunnel tests by the National Advisory Committee for Aeronautics (NACA) and later by NASA, the National Aeronautics and Space Administration. This data is most conveniently presented in plots of lift coefficient versus angle of attack, pitching moment coefficient versus angle of attack, drag coefficient versus lift coefficient, and pitching moment coefficient versus lift coefficient and is found in literally hundreds of NACA and NASA Reports, Notes, and Memoranda published since the 1920s.

Many of the more important airfoil shapes have their test results summarized in the *Theory of Wing Sections*, a Dover paperback publication authored by Ira Abbott and Albert Von Doenhoff and first published in 1949. While the date of original publication might lead one to think this material must be out of date, that is simply not true and the *Theory of Wing Sections* is one of the most valuable references in any aerospace engineer's personal library.

In the following appendix material a selection of airfoil graphical data is presented which can be found in the *Theory of Wing Sections* and in the non-copyrighted NACA publications which are the source of the Dover publication's data. The airfoils presented represent a cross section of airfoil shapes selected to illustrate why one would select one airfoil over another for any given aircraft design or performance requirement.

Figure A-1 shows data for the NACA 0012 airfoil, a classic symmetrical shape that is used for everything from airplane stabilizers and canards to helicopter rotors to submarine "sails". Note that for the symmetrical shape the lift coefficient is zero at zero angle of attack. These graphs show test results for several different Reynolds numbers and for "standard roughness" on the surface. They also show what happens when a 20% chord flap is deflected 40 degrees. Note that the flap deflection shifts the lift curve far to the left giving a zero lift angle of attack of roughly minus 12 degrees while it increases the maximum lift coefficient ($Re = 6 \times 10^6$) from just under 1.6 to 2.4, a huge increase in lifting capability that can contribute to large decreases in takeoff and landing distances. Also note that the pitching moment coefficient at $c/4$ (in the left hand graph) is essentially zero from -12 degrees to +14 degrees angle of attack and then goes negative in stall at positive angle of attack. In the right hand graph the moment curve shown is for the moment at the "aerodynamic center" rather than the quarter chord but since it is also zero in this plot it confirms the theoretical prediction that for a symmetrical airfoil the center of pressure (where the moment is zero) coincides with the aerodynamic center.

Figure A-2 gives similar data for the NACA 2412 airfoil, another 12% thick shape but one with camber. Note that the lift coefficient at zero angle of attack is no longer zero but is approximately 0.25 and the zero lift angle of attack is now minus two degrees, showing the effects of adding 2% camber to a 12% thick airfoil. Also note that the moment coefficient at the quarter chord is no longer zero but is still relatively constant between the onset of positive and negative stall. The moment coefficient is negative over most of the range of angle of attack indicating a nose down pitching moment and positive stability. Adding 2% camber has also resulted in a slight increase in CL_{max} from about 1.6 to 1.7 when compared to the 0012 airfoil.

When Figure A-3 is compared with A-1 and A-2 one can see the effect of added thickness as the percent thickness increases from 12 to 15 percent. This shows up primarily as a slight increase in drag coefficient and a slight reduction in CL_{max} compared to the 12% thick equally cambered airfoil in A-2.

Figure A-4 returns to a 12% thick airfoil but one with 4% camber and a comparison with the previous figures will show how the increase in camber increases the lift at zero angle of attack, takes the zero lift angle of attack down to minus four degrees and increases the nose down pitching moment which is still constant between stall angles when measured at the quarter chord (aerodynamic center).

Figures A-5 and A-6 are for "6-series" airfoils, the so-called "laminar flow" airfoil series developed in the 1930s and used extensively in wing designs well into the late 1900s. Both figures show 12% thick airfoils. The distinguishing features of these graphs are the pronounced "drag buckets" in the right hand plots. Note that the first number to the right of the hyphen in the airfoil designation tells the location of the center of the drag bucket; i.e., the center of the bucket is at a CL of 0.1 for the 641-112 and at 0.4 for the 641-412. In this manner the airfoil designation in the "6-series" is a handy tool for the designer, allowing easy selection

of an airfoil that has its “drag bucket” centered at perhaps the cruise lift coefficient for a transport aircraft or at the lift coefficient which is best for climb or maneuver in a fighter. Also note that the difference in camber produces the same kind of shifts in the lift curve as noted in the 4 digit series airfoils in the earlier plots.

These 6 plots are just the tip of the iceberg when exploring the many airfoil shapes which have been investigated by the NACA, NASA, and others over the years but the general features noted above will hold true for almost any variations in airfoil shape.

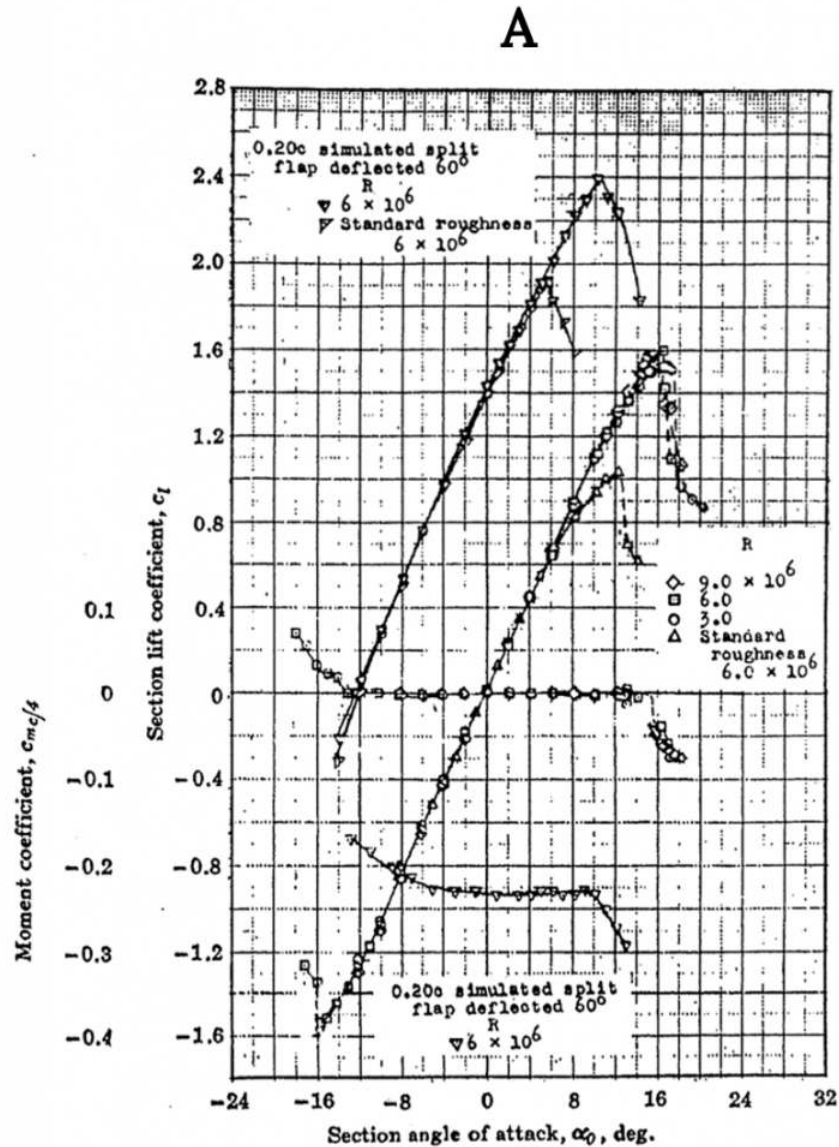

Figure A-1 (A): NACA 0012 Airfoil Data

B

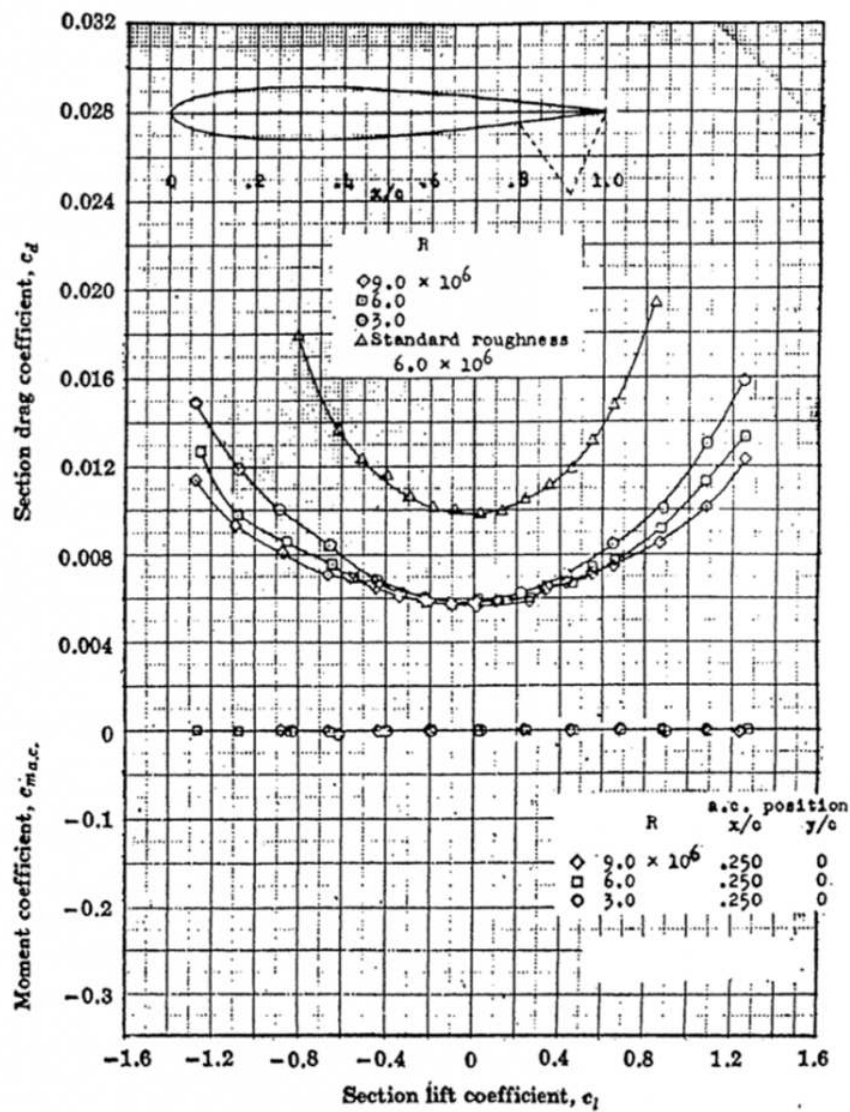

Figure A-1 (B): NACA 0012 Airfoil Data

A

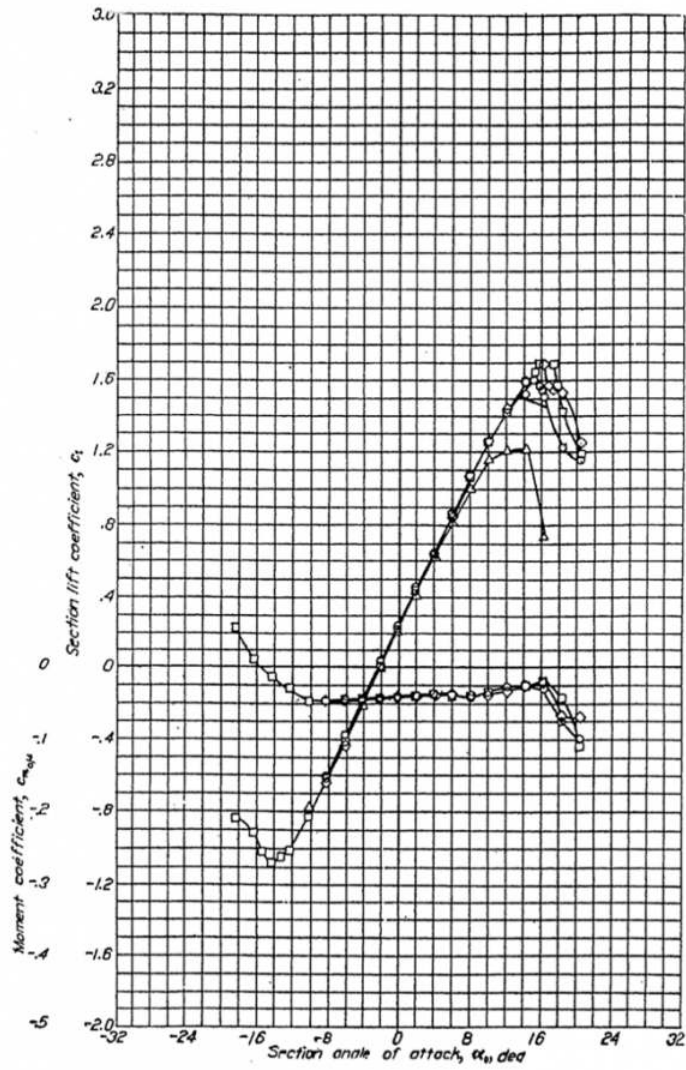

Figure A-2 (A): NACA 2412 Airfoil Data

B

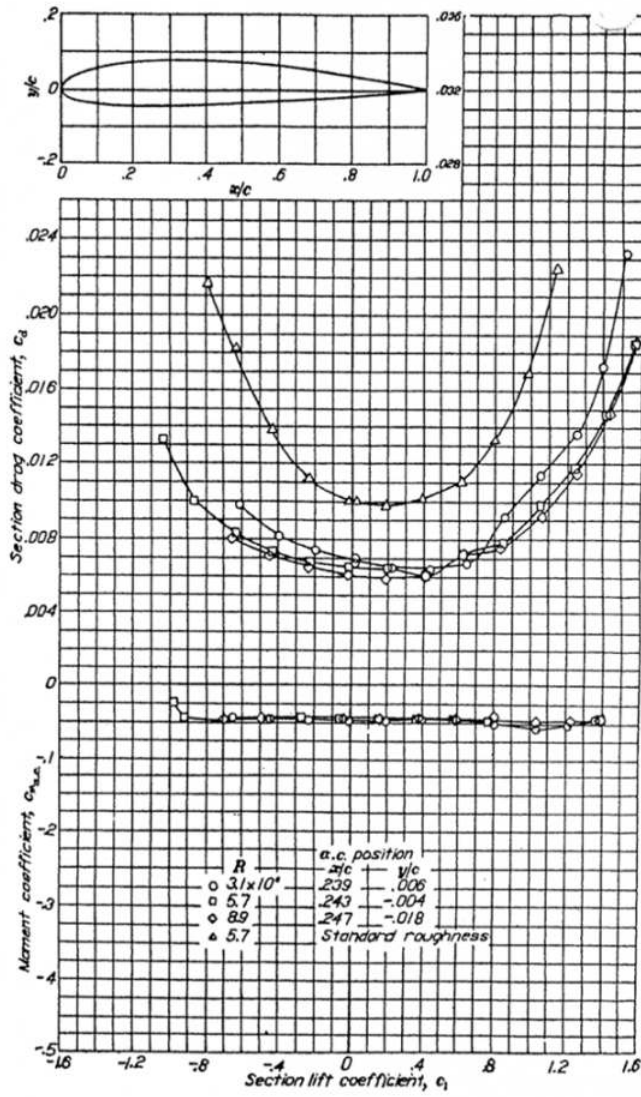

Figure A-2 (B): NACA 2412 Airfoil Data

A

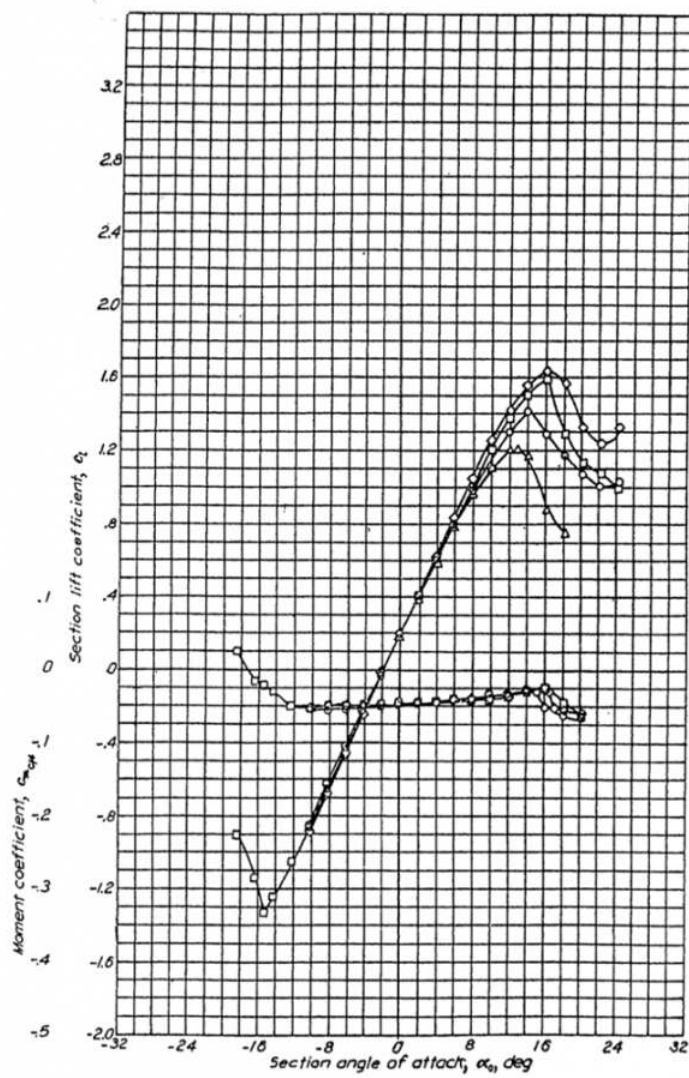

Figure A-3 (A): NACA 2415 Airfoil Data

B

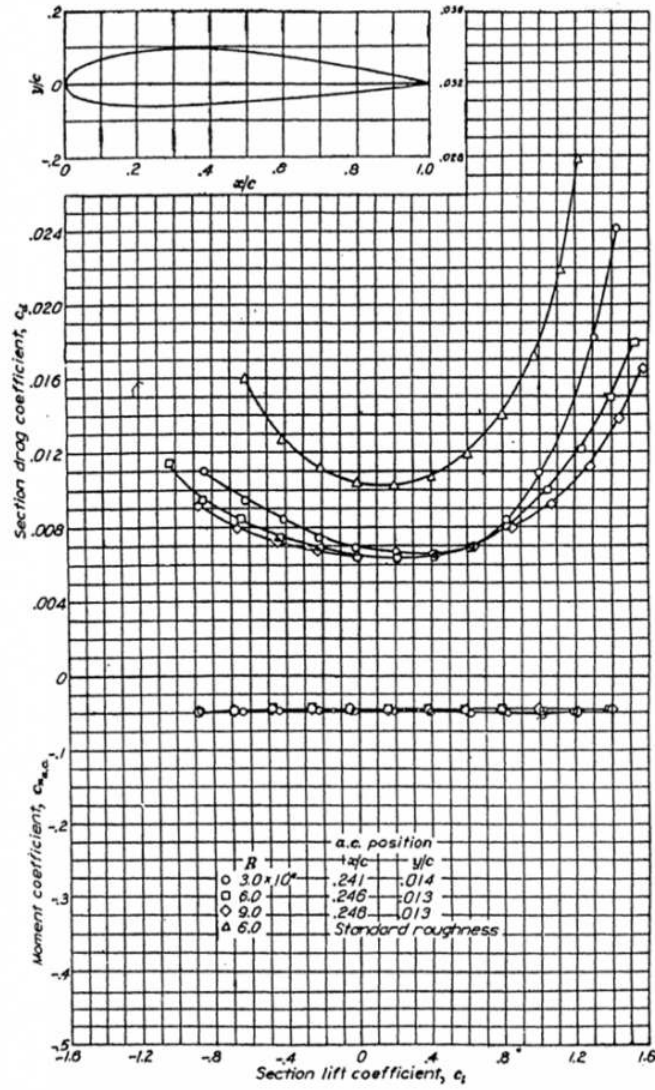

Figure A-3 (B): NACA 2415 Airfoil Data

A

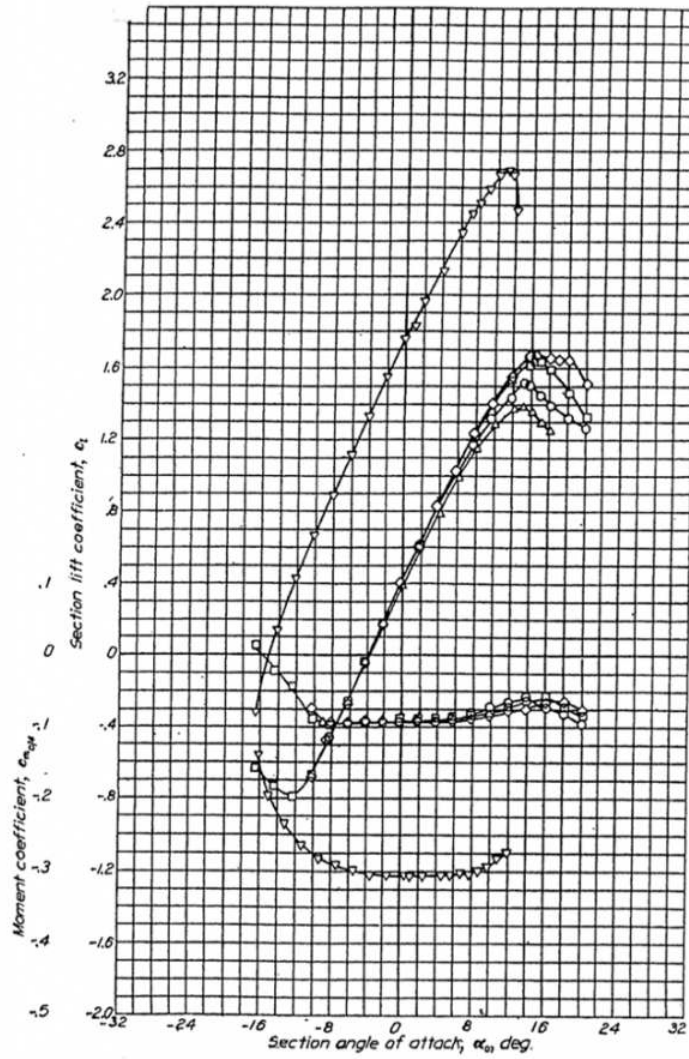

Figure A-4 (A): NACA 4412 Airfoil Data

B

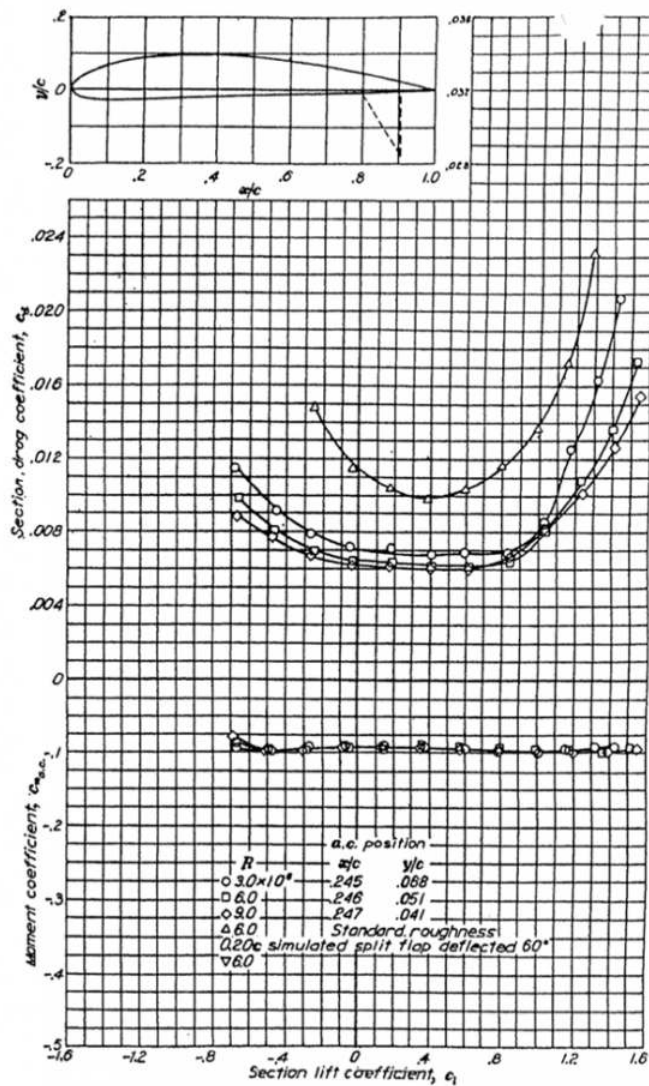

Figure A-4 (B): NACA 4412 Airfoil Data

A

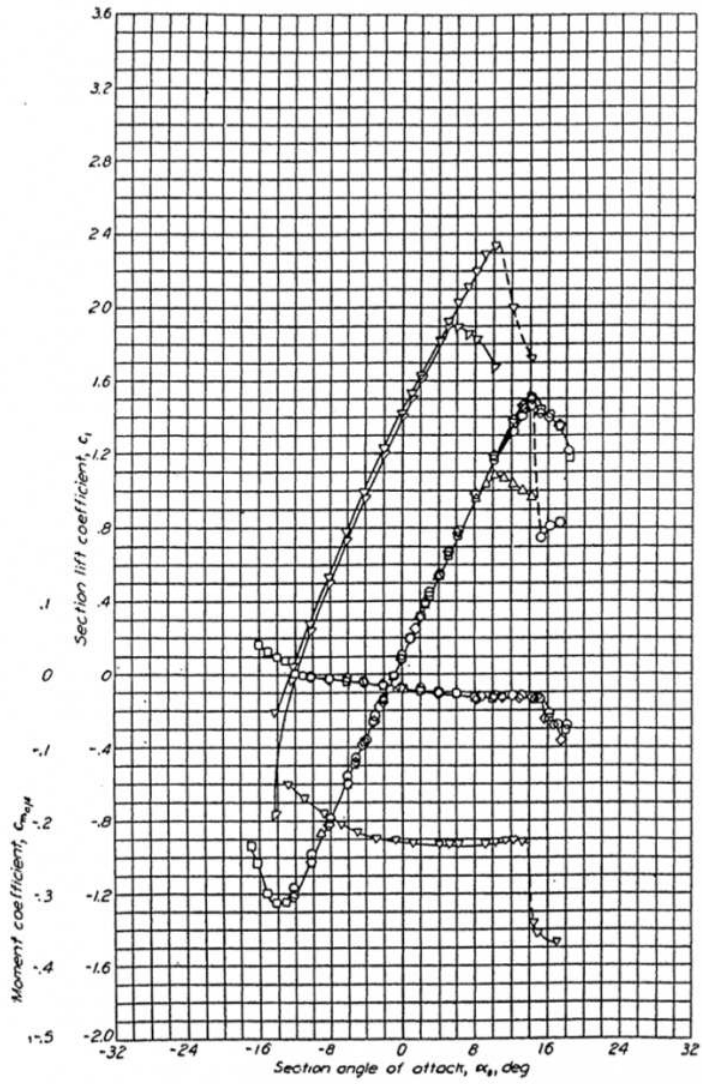

Figure A-5 (A): NACA 64 (sub 1)-112 Airfoil Data

B

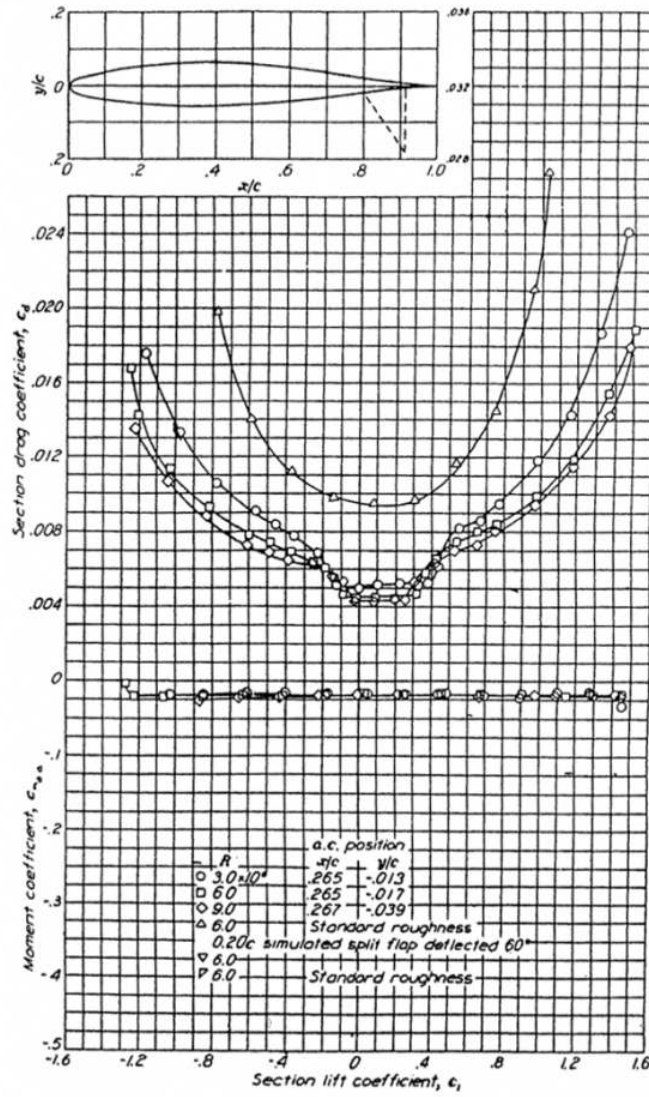

Figure A-5 (B): NACA 64 (sub 1)-112 Airfoil Data

A

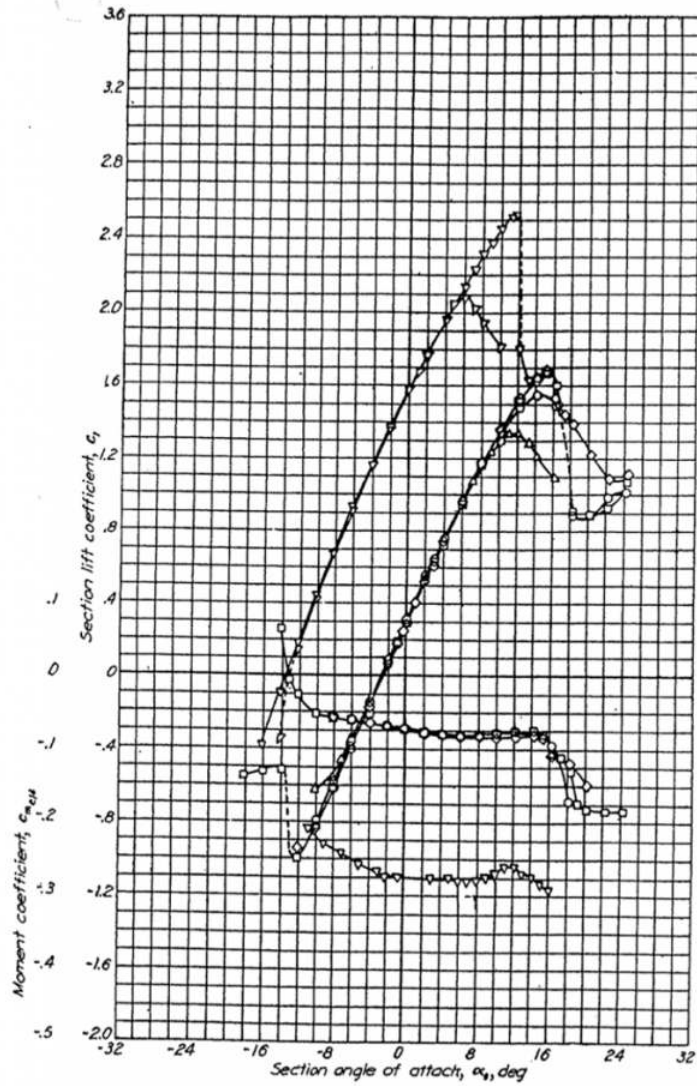

Figure A-6 (A): NACA 64 (sub 1)-412 Airfoil Data

B

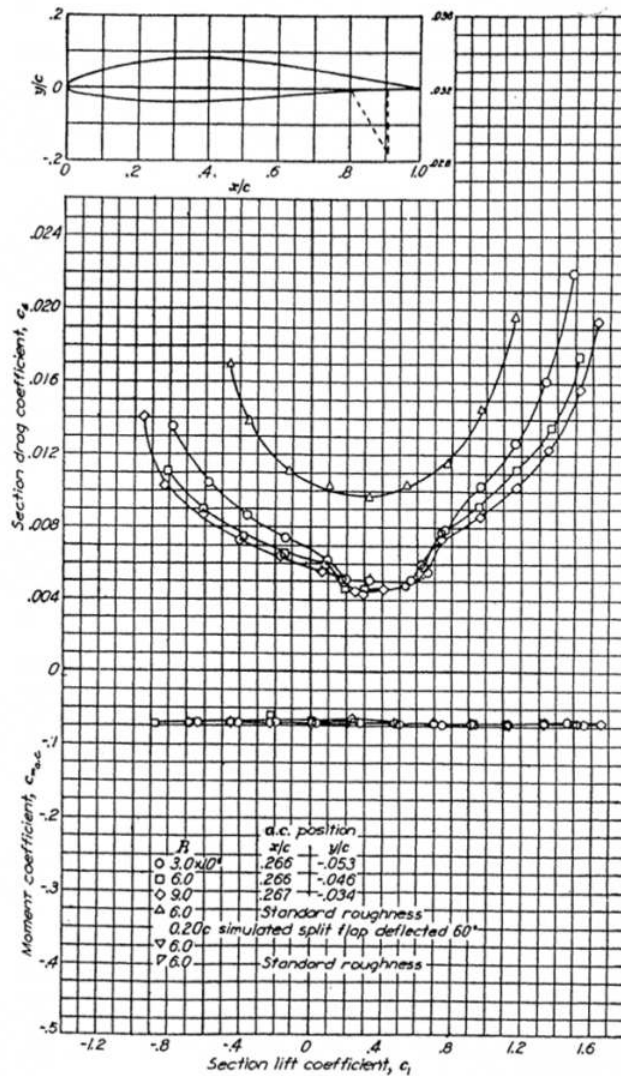

Figure A-6 (B): NACA 64 (sub 1)-412 Airfoil Data

References

Figure A1.1: Kindred Grey (2021). "NACA 0012 Airfoil Data." [CC BY 4.0](https://archive.org/details/0012_20210805). Adapted from NACA. Public domain. Available from https://archive.org/details/0012_20210805

Figure A1.2: Kindred Grey (2021). "NACA 2412 Airfoil Data." [CC BY 4.0](https://archive.org/details/2412_20210805). Adapted from NACA. Public domain. Available from https://archive.org/details/2412_20210805

Figure A1.3: Kindred Grey (2021). "NACA 2415 Airfoil Data." [CC BY 4.0](https://archive.org/details/2415_20210805). Adapted from NACA. Public domain. Available from https://archive.org/details/2415_20210805

Figure A1.4: Kindred Grey (2021). "NACA 4412 Airfoil Data." [CC BY 4.0](https://archive.org/details/4412_20210805). Adapted from NACA. Public domain. Available from https://archive.org/details/4412_20210805

Figure A1.5: Kindred Grey (2021). "NACA 64_1-112 Airfoil Data." [CC BY 4.0](https://archive.org/details/64-112). Adapted from NACA. Public domain. Available from <https://archive.org/details/64-112>

Figure A1.6: Kindred Grey (2021). “NACA 64_1-412 Airfoil Data.” [CC BY 4.0](#). Adapted from NACA. Public domain. Available from <https://archive.org/details/64-412>

This page titled [10: Appendix - Airfoil Data](#) is shared under a [CC BY 4.0](#) license and was authored, remixed, and/or curated by [James F. Marchman](#) ([Virginia Tech Libraries' Open Education Initiative](#)) via [source content](#) that was edited to the style and standards of the LibreTexts platform.

Index

D

dire

Glossary

Sample Word 1 | Sample Definition 1

Detailed Licensing

Overview

Title: [Aerodynamics and Aircraft Performance 3e \(Marchman\)](#)

Webpages: 24

All licenses found:

- [CC BY 4.0](#): 62.5% (15 pages)
- [Undeclared](#): 37.5% (9 pages)

By Page

- [Aerodynamics and Aircraft Performance 3e \(Marchman\)](#) - [CC BY 4.0](#)
 - [Front Matter](#) - *Undeclared*
 - [TitlePage](#) - *Undeclared*
 - [InfoPage](#) - *Undeclared*
 - [Table of Contents](#) - *Undeclared*
 - [How to Adopt or Adapt this Book](#) - [CC BY 4.0](#)
 - [Licensing](#) - *Undeclared*
 - [Acknowledgments](#) - [CC BY 4.0](#)
 - [Preface](#) - [CC BY 4.0](#)
 - [Introduction](#) - [CC BY 4.0](#)
 - [1: Introduction to Aerodynamics](#) - [CC BY 4.0](#)
 - [2: Propulsion](#) - [CC BY 4.0](#)
 - [3: Additional Aerodynamics Tools](#) - [CC BY 4.0](#)
 - [4: Performance in Straight and Level Flight](#) - [CC BY 4.0](#)
 - [5: Altitude Change - Climb and Guide](#) - [CC BY 4.0](#)
 - [6: Range and Endurance](#) - [CC BY 4.0](#)
 - [7: Accelerated Performance - Takeoff and Landing](#) - [CC BY 4.0](#)
 - [8: Accelerated Performance - Turns](#) - [CC BY 4.0](#)
 - [9: The Role of Performance in Aircraft Design - Constraint Analysis](#) - [CC BY 4.0](#)
 - [10: Appendix - Airfoil Data](#) - [CC BY 4.0](#)
 - [Back Matter](#) - *Undeclared*
 - [Index](#) - *Undeclared*
 - [Glossary](#) - *Undeclared*
 - [Detailed Licensing](#) - *Undeclared*